

Stepping Motors catalogue



SANYO DENKI
Step-Syn

Stepping Motors catalogue

SANYO DENKI
Step-Syn



SANYO DENKI, established in 1927, began the development and production of stepping motors in 1959. The experience and skills accumulated in more than 40 years of activity has today made the company an international leader in this sector, both for design and development potential of new high-performance products and for mass-production capability of the introduced technological innovations.

Mass-production (several millions of units per year) is carried out making use of fully automated lines. In this way, an excellent price/performance ratio is insured, in connection with constant quality and a large repeatability of the characteristics of each item.

This range of motors proposed by R.T.A., selected from the more than 800 models in the SANYO DENKI 's catalogue and supported by a very large stock of motors, always available at the warehouse, allows to face and solve in the best way a great variety of automation problems.

The wide range of drives produced by R.T.A. (more than 30 standard models, equipped with a wide series of accessories, interface cards and options) is the ideal complement to SANYO DENKI stepping motors, permitting the optimization of their potential, whilst the experience in the design of drives and the solution of practical problems, perfected in more than 20 years of activity, allows the offering of sound support for the optimal solution of the customer's requirements.

At present, both SANYO DENKI and R.T.A. have implemented Quality Assurance Systems certified according to ISO 9001 (JQA - 2837 and TÜV - 50 100 2153, respectively), following the strategic policy of improving the quality of the products and services offered to Customers.





STANDARD MOTORS	HOLDING TORQUE (Ncm.)	TECHNICAL DATA (page)	SPEED / TORQUE CURVES (page)
SIZE 1.7"			
103-546-55500	12.5	3	--
103-546-5342	19	3	13
103-547-52500	25	3	13
SIZE 2.2"			
103-770-6	62	4	13
103-770-1640	62	4	13
103-G770-2241	60	4	13
103-714-0150	109	5	13 - 14
SIZE 3.4"			
103-807-6241	170	6	14
103-807-6341	170	6	14
103-810-6	275	7	14
103-814-6541	345	7	14
103-845-6741	510	8	15
103-845-67S1	510	9	--
103-845-67S41	510	10	--
SIZE 4.2"			
103-8932-6451	1330	11	15-16
103-8960-6551	2060	11	16
H SERIES MOTORS			
SIZE 1.7"			
103-H548-04500	37	18	28
SIZE 50 mm.			
103-H6701-0140	38	19	28
103-H6703-0440	68	19	28
SIZE 2.2"			
103-H7123-0140	110	20	28
103-H7123-0440	110	20	--
103-H7123-0740	110	20	28
103-H7123-1740	110	20	29
103-H7126-0140	165	21	29
103-H7126-0740	165	21	29
103-H7126-1740	165	21	29
103-H7126-6640	165	22	29
SIZE 60 mm.			
103-H7823-1741	300	23	29
SIZE 3.4"			
103-H8222-63XE42	560	24	--
103-H8221-6241	300	25	29
103-H8222-6340	560	25	30
103-H8223-6540	790	25	30
SIZE 4.2"			
103-H89222-6541	1620	26	30-31
103-H89223-6641	2460	26	31



Warning

For connection with R.T.A. drives, see pages 32 / 33. All indicated values are to be considered as typical.

- The sole purpose of this catalogue is as a general introduction to our products, in order to allow an orientation as well as a choice among them. Detailed information concerning limitations and installation/utilization procedures are described in the manuals and/or technical sheets relating to each product. It is therefore essential to strictly refer to these enclosed technical manuals for a correct use, in accordance with current standards.
- All those products for which a specific obligation is required, as per law regulation in force in the European Community countries, bear the EC marking stating they are in accordance with the related directives (depending on the products, EEC directive 73/23 and/or 89/336 and subsequent modifications and integration).
- All products are classed as components exclusively designed and sold for installation in machines or equipments by a technically competent user, who will undertake the responsibility of safety and EMC requirements of the complete system.
- R.T.A. reserves the right to modify the products at any time and without prior notice (including, but not limited to, characteristics, availability and prices).

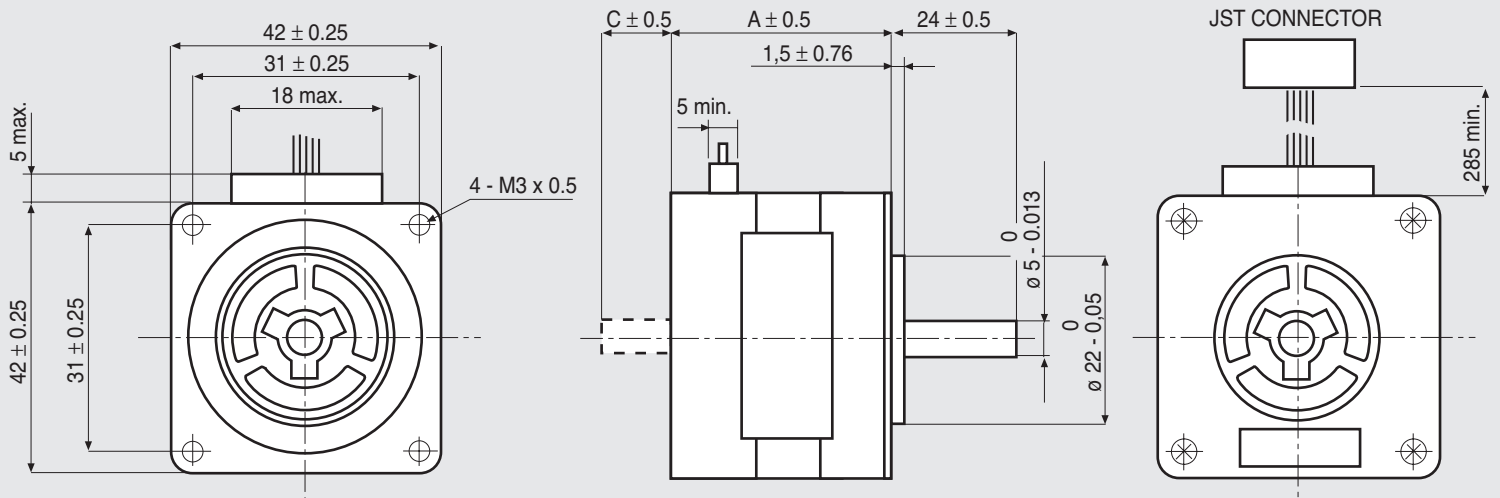

MOTOR CONNECTOR IS JST mod. EHR-4 / EHR-6 A 4 / 6 POLES FEMALE.
FOR CONNECTION USE JST mod. B4B-EH-A / B6B-EH-A MALE CONNECTOR.

MODEL	A	C
103 - 546 - 55500	32.5	
103 - 546 - 5342	32.5	
103 - 547 - 52500	36.5	
103 - 547 - 52300	36.5	15

CHARACTERISTICS

MODEL	103 - 546 - 55500	103 - 546 - 5342	103 - 547 - 52500 (103 - 547 - 52300)
BASIC STEP ANGLE	1.8° ± 0.09°	1.8° ± 0.09°	1.8° ± 0.09°
BIPOLAR PARALLEL CURRENT (Amp)	0.2	0.42 ^(*)	0.7 ^(*)
UNIPOLAR CURRENT (Amp)		0.6	1.0
RESISTANCE (Ohm)	37.5	6.7	3.15
INDUCTANCE (mH)	52	5.4	3
BIPOLAR HOLDING TORQUE (Ncm)	12.5	19	25
UNIPOLAR HOLDING TORQUE (Ncm)		14.5	19
ROTOR INERTIA (Kgm ² x 10 ⁻⁷)	20	30	43
THEORETICAL ACCELERATION (rad x sec. ⁻²)	63000	63000	59000
BACK E.M.F. (V/Krpm)	47	18	14
MASS (Kg)	0.2	0.2	0.24
LEADS CODE	V	IV	IV

Codes between brackets refer to double shaft model.

^(*) Series connection

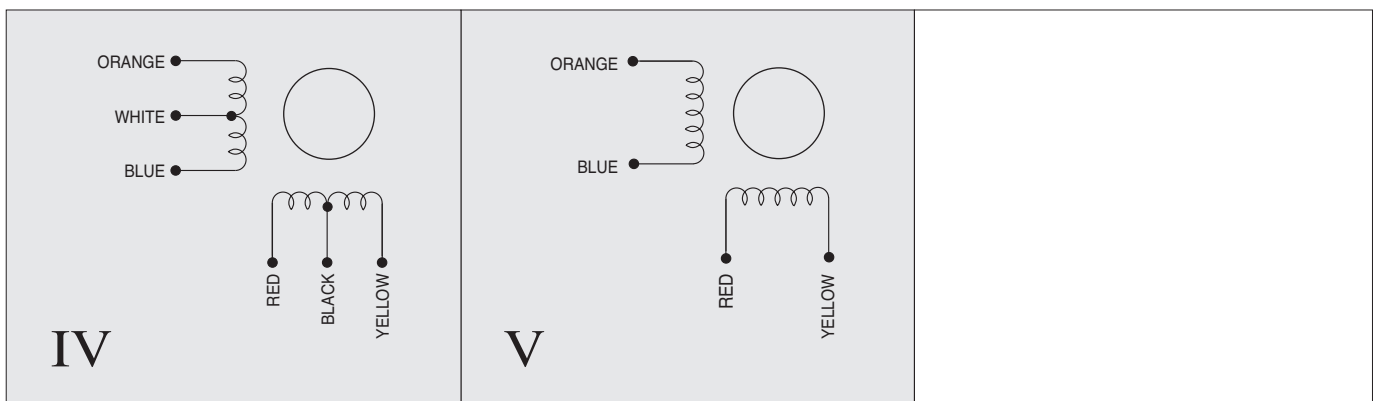

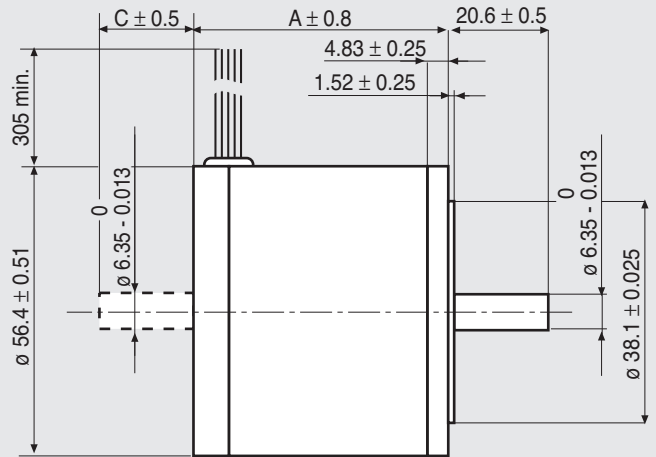
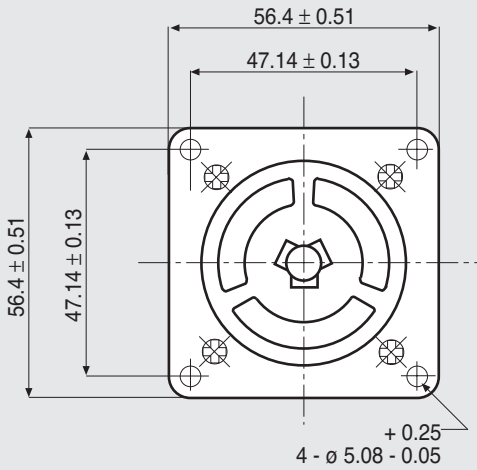

MODEL	A	C
103 - 770 - 6	50.8	
103 - 770 - 61	50.8	19.05
103 - G770 - 2241	50.8	
103 - G770 - 2221	50.8	19.05
103 - 770 - 1640	50.8	

CHARACTERISTICS

MODEL	103 - 770 - 6 (103 - 770 - 61)	103 - G770 - 2241 (103 - G770 - 2221)	103 - 770 - 1640
BASIC STEP ANGLE	1.8° ± 0.09°	1.8° ± 0.09°	1.8° ± 0.09°
BIPOLAR PARALLEL CURRENT (Amp)	1.41 (*)	2.82 (*)	1.41
UNIPOLAR CURRENT (Amp)	1.0	2.0	
RESISTANCE (Ohm)	5.1	1.4	2.6
INDUCTANCE (mH)	9.0	2.2	9.0
BIPOLAR HOLDING TORQUE (Ncm)	62	60	62
UNIPOLAR HOLDING TORQUE (Ncm)	49	47	
ROTOR INERTIA (Kgm ² x 10 ⁻⁷)	105	105	105
THEORETICAL ACCELERATION (rad x sec. ⁻²)	59000	52000	59000
BACK E.M.F. (V/Krpm)	37	17	33
MASS (Kg)	0.54	0.54	0.54
LEADS CODE	I	I (II)	V

Codes between brackets refer to double shaft model.

(*) Parallel connection.

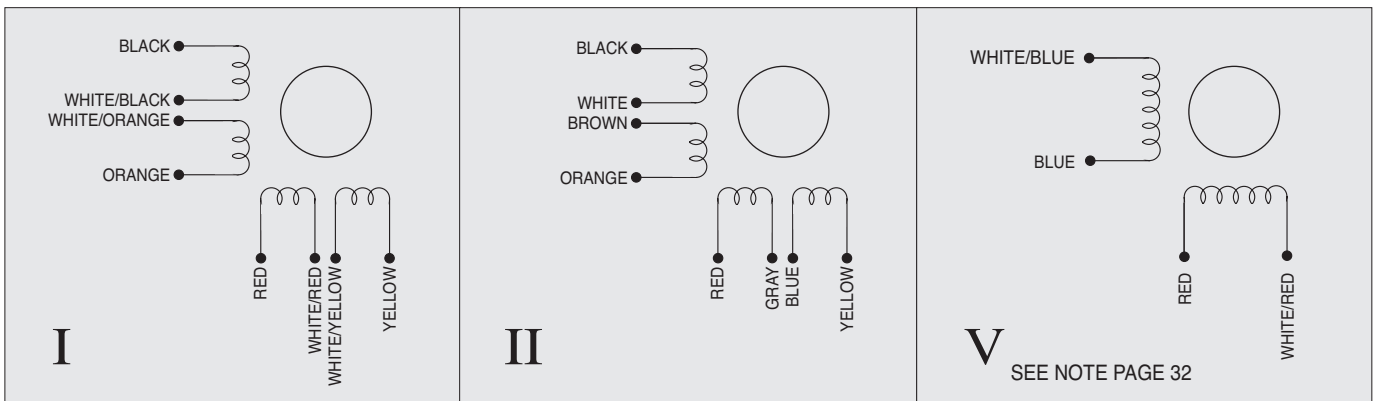

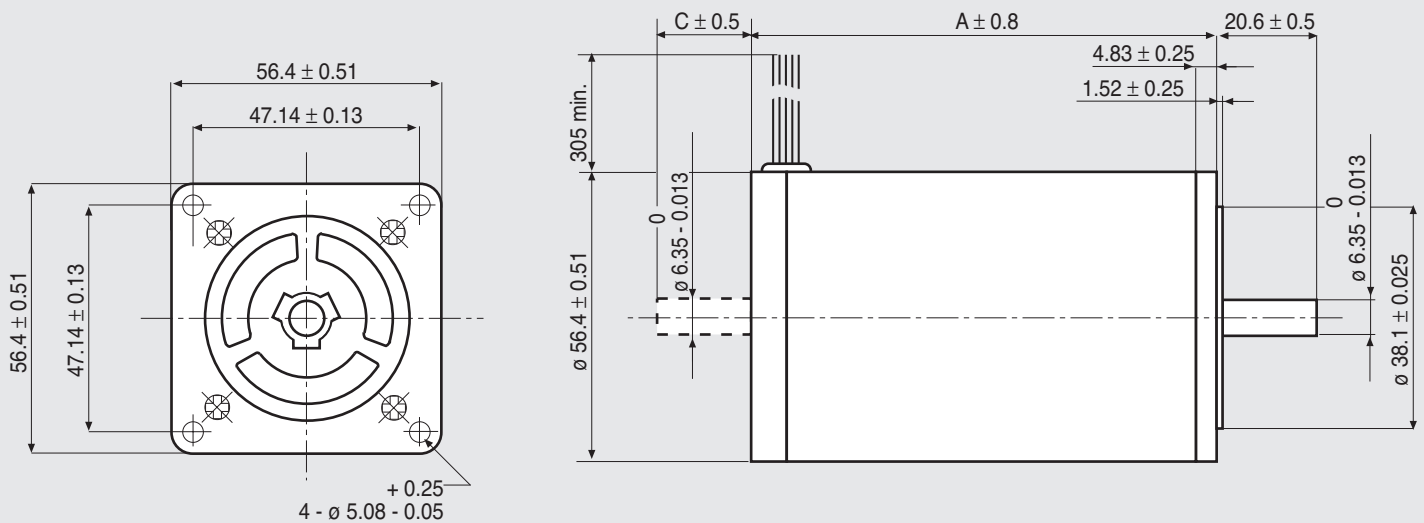

MODEL	A	C
103 - 714 - 0150	76.2	
103 - 714 - 0111	76.2	19.5

CHARACTERISTICS

MODEL		103 - 714 - 0150 (103 - 714 - 0111)
BASIC STEP ANGLE		1.8° ± 0.09°
BIPOLAR PARALLEL CURRENT	(Amp)	2.55
UNIPOLAR CURRENT	(Amp)	1.8
RESISTANCE	(Ohm)	2.6
INDUCTANCE	(mH)	4.9
BIPOLAR HOLDING TORQUE	(Ncm)	109
UNIPOLAR HOLDING TORQUE	(Ncm)	88
ROTOR INERTIA	(Kgm ² x 10 ⁻⁷)	210
THEORETICAL ACCELERATION	(rad x sec. ⁻²)	51000
BACK E.M.F.	(V/Krpm)	36
MASS	(Kg)	0.95
LEADS CODE		II

Codes between brackets refer to double shaft model.

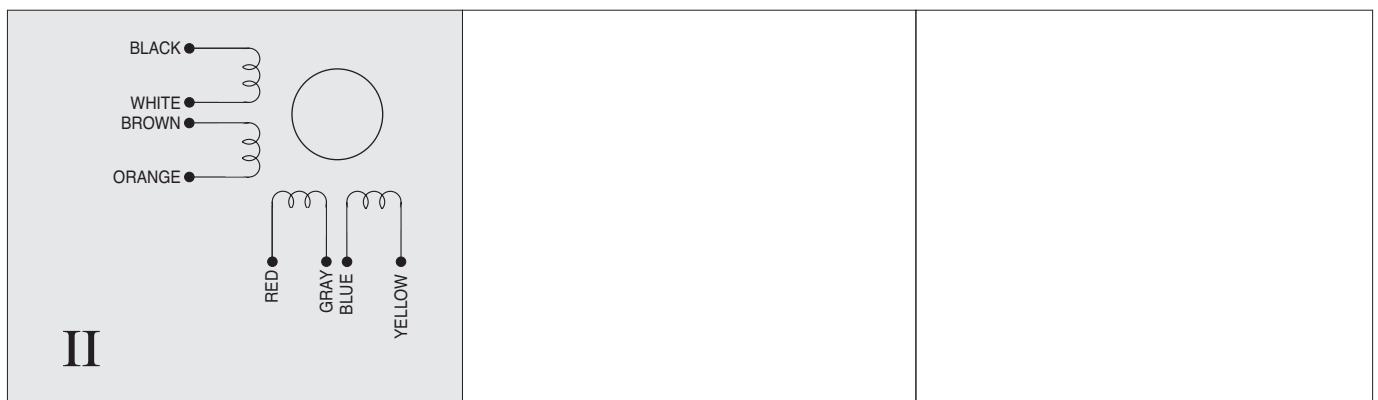

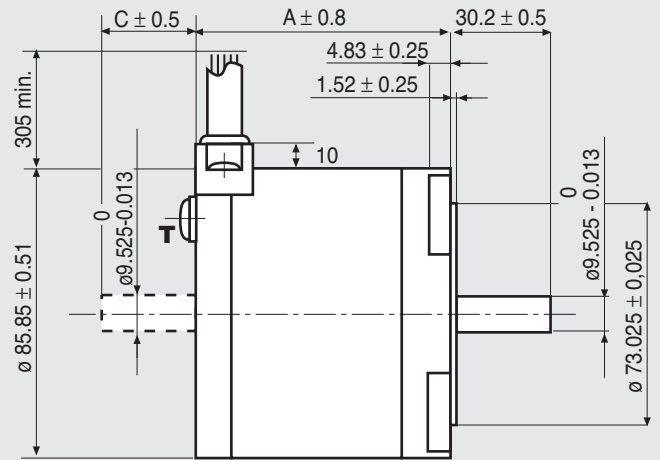
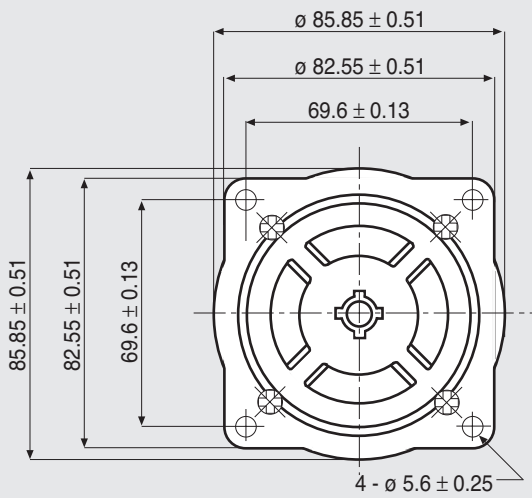

WIRES ARE HOUSED IN A VINYL TUBE.
T IS THE EARTH TERMINAL

MODEL	A	C
103 - 807 - 6241	61	
103 - 807 - 6341	61	
103 - 807 - 6311	61	28.5

CHARACTERISTICS

MODEL	103 - 807 - 6241	103 - 807 - 6341 (103 - 807 - 6311)
BASIC STEP ANGLE	1.8° ± 0.09°	1.8° ± 0.09°
BIPOLAR PARALLEL CURRENT (Amp)	2.7	4.3
UNIPOLAR CURRENT (Amp)	1.9	3.05
RESISTANCE (Ohm)	2.65	0.95
INDUCTANCE (mH)	8.2	3.8
BIPOLAR HOLDING TORQUE (Ncm)	170	170
UNIPOLAR HOLDING TORQUE (Ncm)	135	135
ROTOR INERTIA (Kg ^m 2 x 10 ⁻⁷)	560	560
THEORETICAL ACCELERATION (rad x sec. ⁻²)	30000	30000
BACK E.M.F. (V/Krpm)	53	33
MASS (Kg)	1.4	1.4
PROTECTION DEGREE	IP43	IP43
LEADS CODE	II	II

Codes between brackets refer to double shaft model.

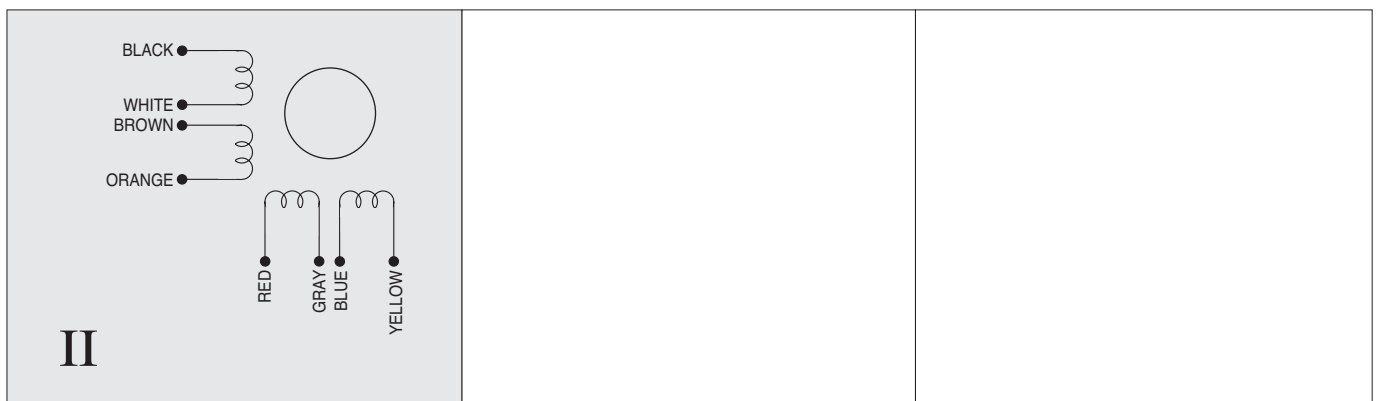

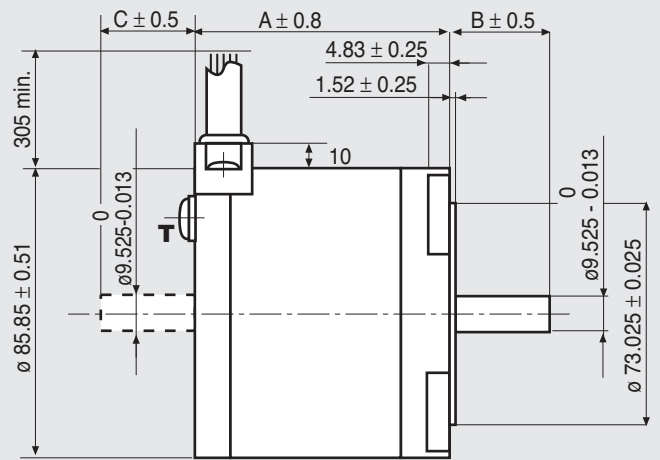
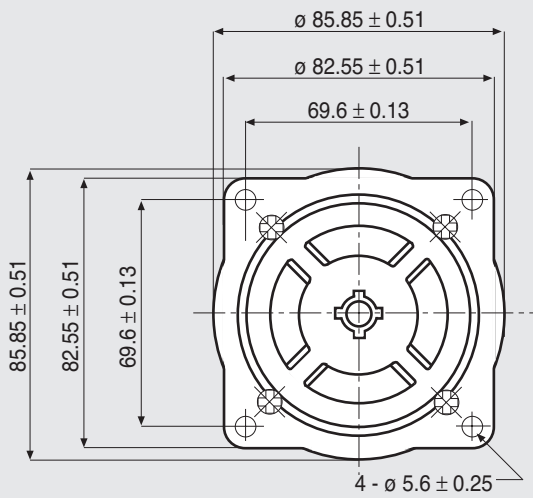

WIRES ARE HOUSED IN A VINYL TUBE.
T IS THE EARTH TERMINAL

MODEL	A	B	C
103 - 810 - 6	93.5	31.8	
103 - 814 - 6541	91.0	30.2	
103 - 814 - 6511	91.0	30.2	30.2

CHARACTERISTICS

MODEL	103 - 810 - 6	103 - 814 - 6541 (103 - 814 - 6511)
BASIC STEP ANGLE	1.8° ± 0.09°	1.8° ± 0.09°
BIPOLAR PARALLEL CURRENT (Amp)	5.6	6.5
UNIPOLAR CURRENT (Amp)	4.0	4.6
RESISTANCE (Ohm)	0.75	0.55
INDUCTANCE (mH)	4.5	2.7
BIPOLAR HOLDING TORQUE (Ncm)	275	345
UNIPOLAR HOLDING TORQUE (Ncm)	220	275
ROTOR INERTIA (Kg ^m 2 x 10 ⁻⁷)	900	1120
THEORETICAL ACCELERATION (rad x sec. ⁻²)	30000	30500
BACK E.M.F. (V/Krpm)	41	44
MASS (Kg)	2.2	2.5
PROTECTION DEGREE		IP43
LEADS CODE	I	II

Codes between brackets refer to double shaft model.

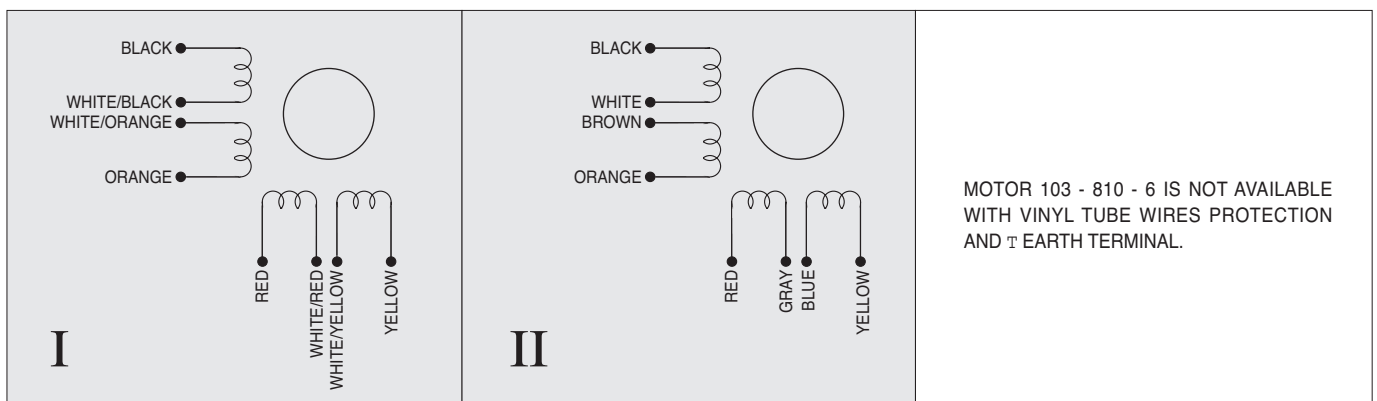

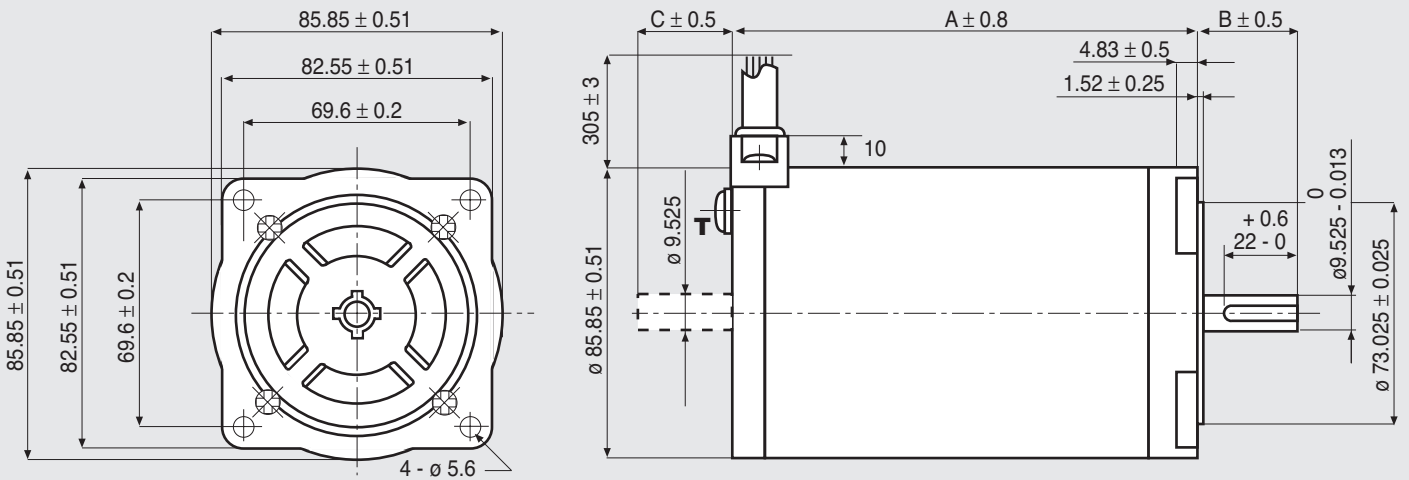

WIRES ARE HOUSED IN A VINYL TUBE.
T IS THE EARTH TERMINAL

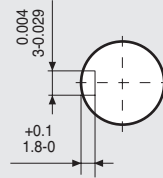
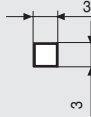
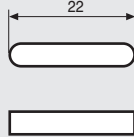

MODEL	A	B	C
103 - 845 - 6741	130.0	30.2	
103 - 845 - 6711	130.0	30.2	25.4

CHARACTERISTICS

MODEL		103 - 845 - 6741 (103 - 845 - 6711)
BASIC STEP ANGLE		1.8° ± 0.09°
BIPOLAR PARALLEL CURRENT	(Amp)	9.5
UNIPOLAR CURRENT	(Amp)	6.7
RESISTANCE	(Ohm)	0.45
INDUCTANCE	(mH)	2.0
BIPOLAR HOLDING TORQUE	(Ncm)	510
UNIPOLAR HOLDING TORQUE	(Ncm)	410
ROTOR INERTIA	(Kgm ² x 10 ⁻⁷)	1550
THEORETICAL ACCELERATION	(rad x sec. ⁻²)	32900
BACK E.M.F.	(V/Krpm)	46
MASS	(Kg)	3.6
PROTECTION DEGREE		IP43
LEADS CODE		II

Codes between brackets refer to double shaft model.

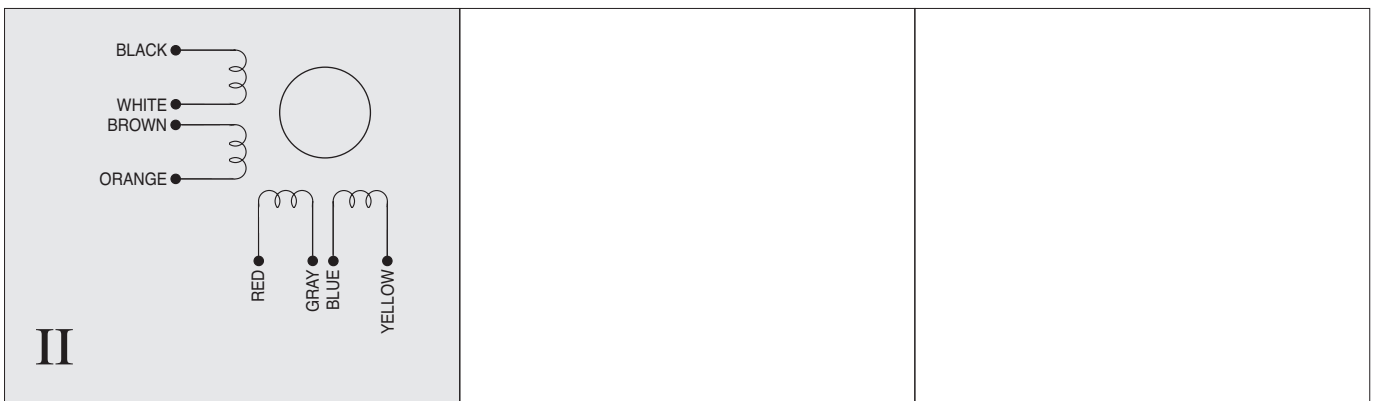

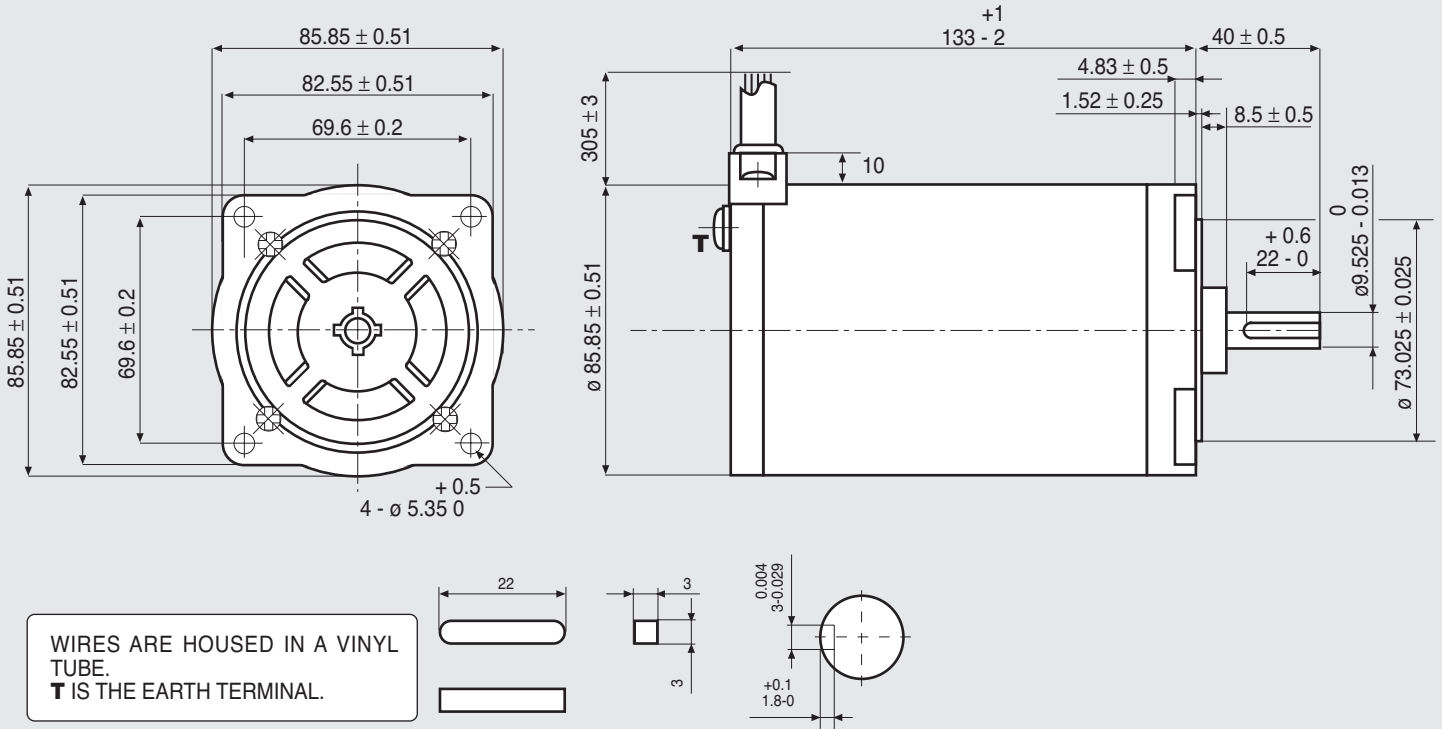

CHARACTERISTICS

MODEL	103 - 845 - 67S1	
BASIC STEP ANGLE	1.8° ± 0.09°	
BIPOLAR PARALLEL CURRENT	(Amp)	9.5
UNIPOLAR CURRENT	(Amp)	6.7
RESISTANCE	(Ohm)	0.45
INDUCTANCE	(mH)	2.0
BIPOLAR HOLDING TORQUE	(Ncm)	510
UNIPOLAR HOLDING TORQUE	(Ncm)	410
ROTOR INERTIA	(Kgm ² x 10 ⁻⁷)	1550
THEORETICAL ACCELERATION	(rad x sec. ⁻²)	32900
BACK E.M.F.	(V/Krpm)	46
MASS	(Kg)	3.6
PROTECTION DEGREE	IP55	
LEADS CODE	II	

© RTA srl PAVIA - MC - 04 - 04

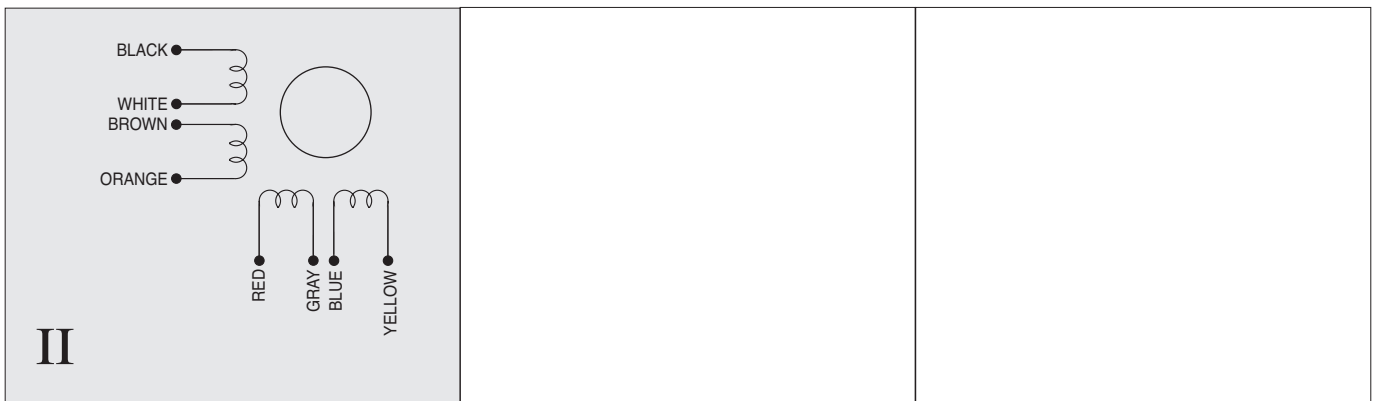

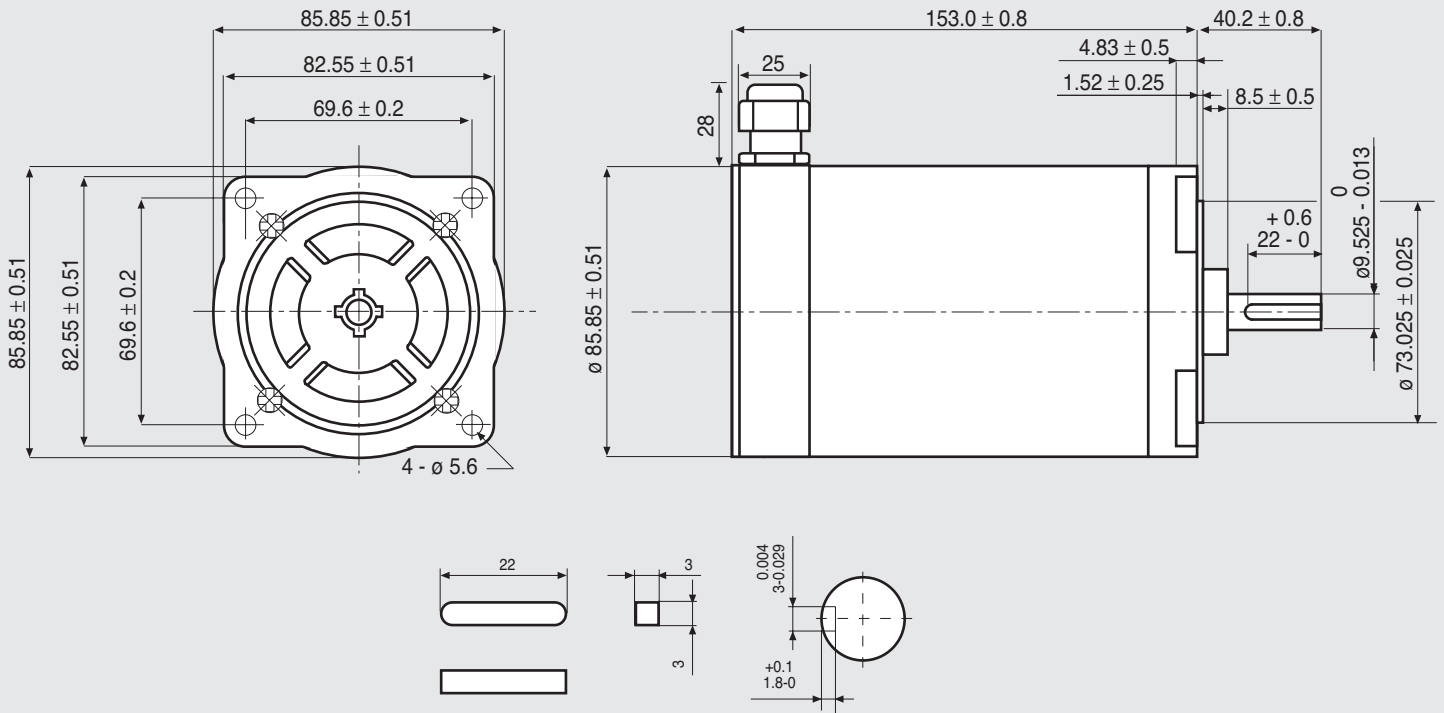

CHARACTERISTICS

MODEL	103 - 845 - 67S41	
BASIC STEP ANGLE	1.8° ± 0.09°	
BIPOLAR PARALLEL CURRENT	(Amp)	9.5
UNIPOLAR CURRENT	(Amp)	6.7
RESISTANCE	(Ohm)	0.45
INDUCTANCE	(mH)	2.0
BIPOLAR HOLDING TORQUE	(Ncm)	510
UNIPOLAR HOLDING TORQUE	(Ncm)	410
ROTOR INERTIA	(Kgm ² x 10 ⁻⁷)	1550
THEORETICAL ACCELERATION	(rad x sec. ⁻²)	32900
BACK E.M.F.	(V/Krpm)	46
MASS	(Kg)	3,9
PROTECTION DEGREE	IP55	
LEADS CODE	VI	

© RTA srl PAVIA - MC - 04 - 04

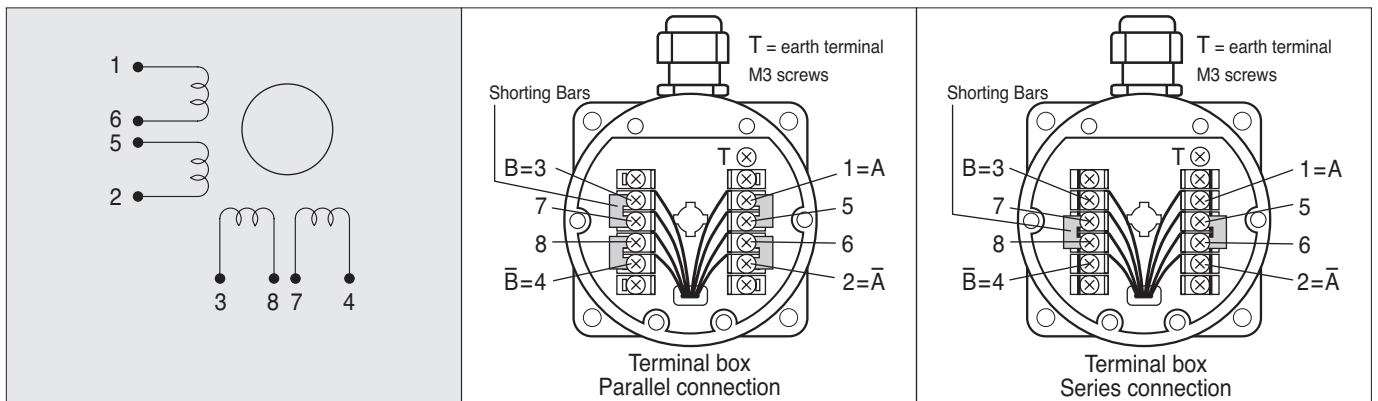

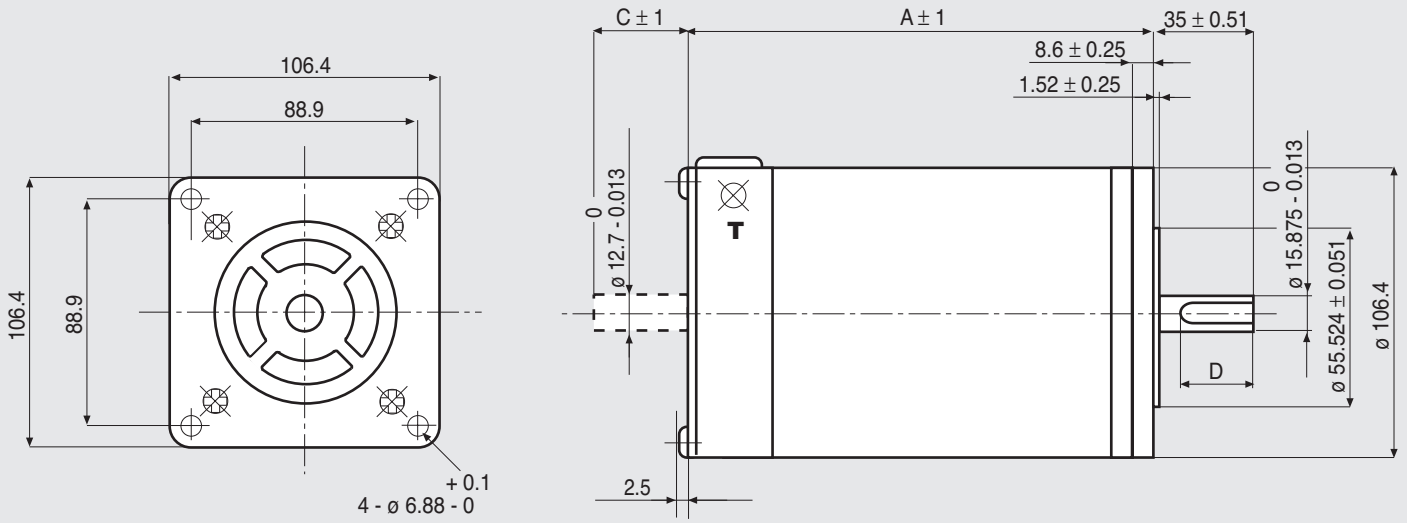

T IS THE EARTH TERMINAL .

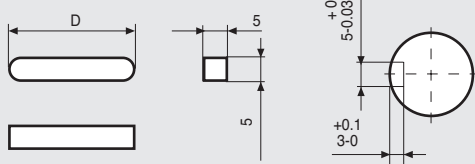

MODEL	A	C	D
103 - 8932 - 6451	186.9		32
103 - 8932 - 6421	186.9	30.8	32
103 - 8960 - 6551	245		28

CHARACTERISTICS

MODEL	103 - 8932 - 6451 (103 - 8932 - 6421)	103 - 8960 - 6551
BASIC STEP ANGLE	$1.8^\circ \pm 0.09^\circ$	$1.8^\circ \pm 0.09^\circ$
BIPOLAR PARALLEL CURRENT (Amp)	12.7	14.1
UNIPOLAR CURRENT (Amp)	9.0	10.0
RESISTANCE (Ohm)	0.28	0.28
INDUCTANCE (mH)	2.4	3.0
BIPOLAR HOLDING TORQUE (Ncm)	1330	2060
UNIPOLAR HOLDING TORQUE (Ncm)	1020	1580
ROTOR INERTIA ($\text{Kg} \cdot \text{m}^2 \times 10^{-7}$)	8000	11500
THEORETICAL ACCELERATION ($\text{rad} \times \text{sec}^{-2}$)	16500	17900
BACK E.M.F. (V/Krpm)	85	120
MASS (Kg)	7	10.5
PROTECTION DEGREE	IP43	IP43
LEADS CODE	III	III

Codes between brackets refer to double shaft model.

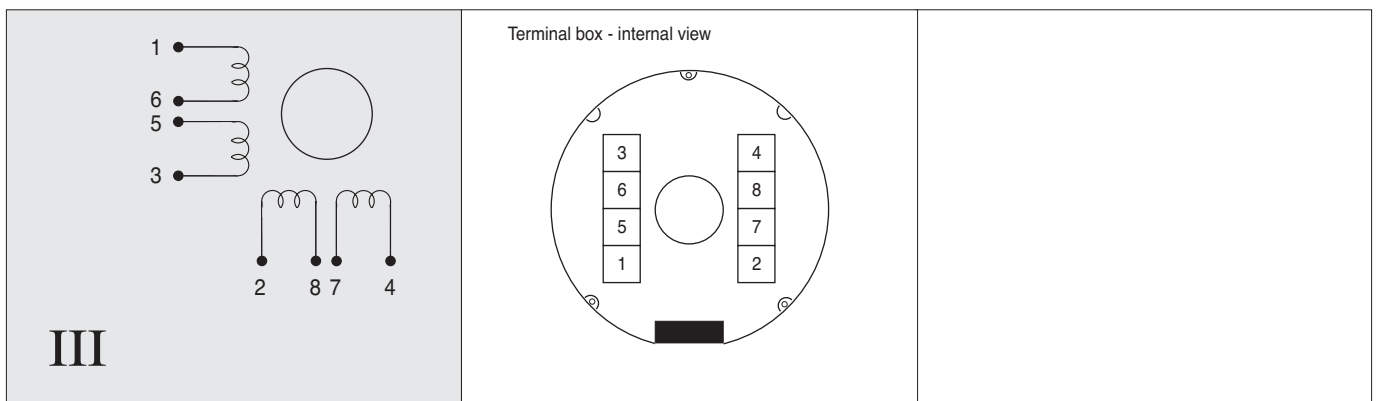

The correct dimensioning of a stepping motor system requires a deep knowledge of the two following essential parameters:

- Mechanical features of the application, as for example inertia of masses in motion, transmission kinematics, speed, acceleration, time required to perform the motion, duty cycle etc.
- Performances of the motor-drive unit, mainly in terms of torque-speed curves.

The torque is not only a feature of the sole motor, but is strongly affected by the drive used with it. The same motor can be used with various drive types in order to obtain different performances in different applications.

Hereafter are reported a selection table and some typical Torque-Speed diagrams obtained with different couplings between RTA drives and SANYO motors. For a correct interpretation of these information, the following considerations apply:

- All reported curves are “pull-out curves”
- Couplings indicated in the selection table take into account only the compatibility between the motor and the power output characteristics of the drive. The effective choice must be made only knowing all requirements of the application like resolution, type of supply, mechanical format etc. (for more information about drive characteristics see also Drive manual)
- At very low speed (<30 RPM) resonance and vibration, strongly dependent by load, could appear with “non ministep-drives” (HGD, GMD, GAC, BCW). This phenomenon is much less critical with “ministep drives” (SDC, SAC, GMH, MIND)
- As the majority of the stepping motor systems, most of the indicated couplings exhibit duty cycle limitations in order to avoid motor overheating. Accessories like motor heatsinks and/or fans are available in case of need
- In the selection table, “YT” means that, for this coupling the specific torque-speed diagram is present; “Y” means that the coupling is rated but the specific torque-speed diagram is not present. For a specific motor, the use of the same background colour in different couplings with different drives means that all those couplings exhibit similar torque-speed characteristics. This means that, when you have a motor with one coupling marked “YT” and three couplings marked “Y” with the same background colour, you can use the torque-speed diagram shown for “YT” also for the other three.

SELECTION TABLE FOR COUPLING BETWEEN STANDARD MOTORS AND DRIVES

MOTOR MODELS AND CONNECTIONS		DRIVE MODELS																		
		HGD		SDC/SAC			GMH			GMD		GAC		MIND			BCW			
		04	06	04	05	06	05	06	07	09	02	03	04	06	03	04	...3	...4	...5	02
546-5342	Parallel*	YT																		
547-52500	Parallel*	YT		Y																
547-52500	Series	YT		Y																
770-1640	—	Y			Y		Y				YT									
G770-2241	Parallel		Y		Y		Y				YT									
G770-2241	Series	Y		Y							YT									
714-0150	Parallel		Y		Y		Y				YT									
807-6241	Parallel		Y		Y		Y				YT									
807-6341	Parallel		Y			Y		Y			YT									
807-6341	Series		Y		Y		Y				YT									
810-6	Parallel		Y			Y		Y			YT							Y		
814-6541	Series		Y			Y		Y			YT									
814-6541	Parallel		Y			Y		Y			YT	Y	YT		Y	Y	Y	Y		
845-6741	Series		Y			Y		Y			YT	Y			Y					
845-6741	Parallel								Y	YT		YT	YT	YT	Y	Y	Y	Y	Y	
8932-6451	Series											YT			Y					
8932-6451	Parallel									YT			YT			Y		Y	Y	YT
8960-6551	Series											YT			Y					
8960-6551	Parallel									YT			YT	YT		Y		Y	Y	YT

* 6-wires motor. For Parallel connection see page 32.



SANYO 103 546 5342 - parallel bipolar connection
RTA HGD04 drive

— torque
— power

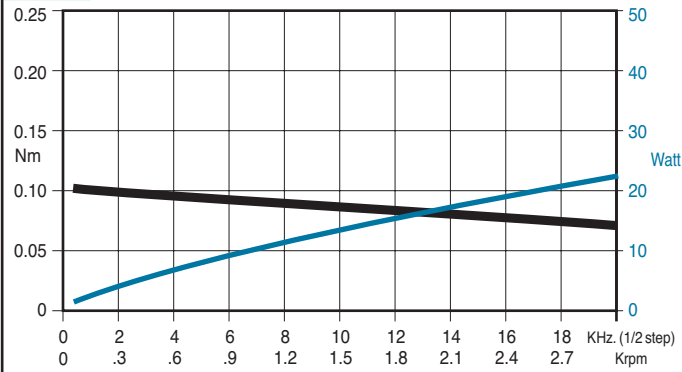

SANYO 103 547 52500 - parallel bipolar connection
RTA HGD04 drive

— torque
— power

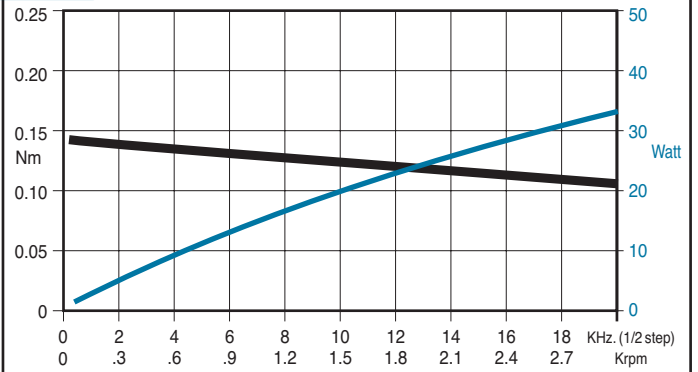

SANYO 103 547 52500 - series bipolar connection
RTA HGD04 drive

— torque
— power

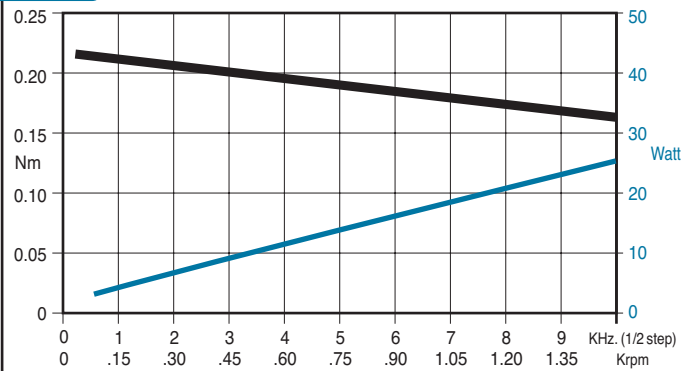

SANYO 103 770 6
24 Volt, 1 Amp. unipolar connection

— torque
— power

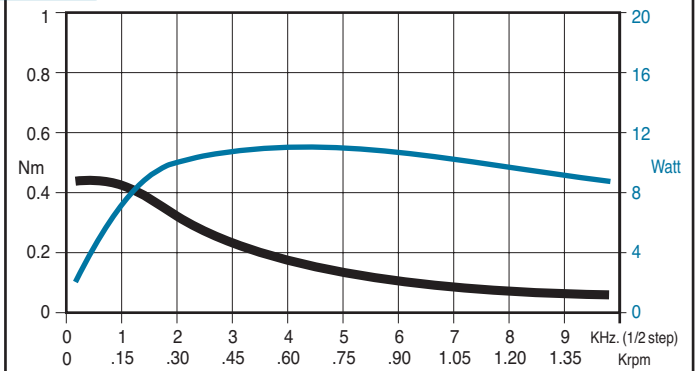

SANYO 103 770 1640 - parallel bipolar connection
RTA GMD02 drive

— torque
— power

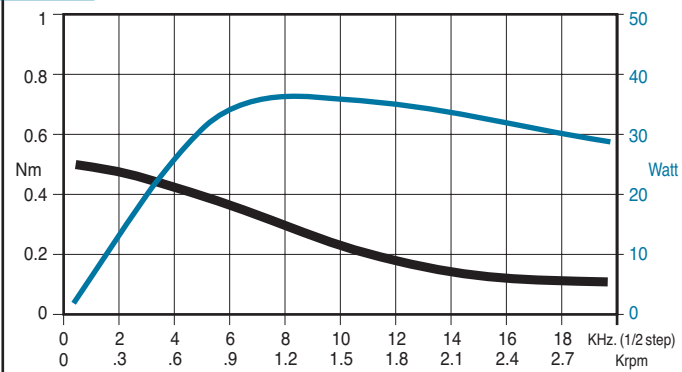

SANYO 103 G770 2241 - series bipolar connection
RTA GMD02 drive

— torque
— power

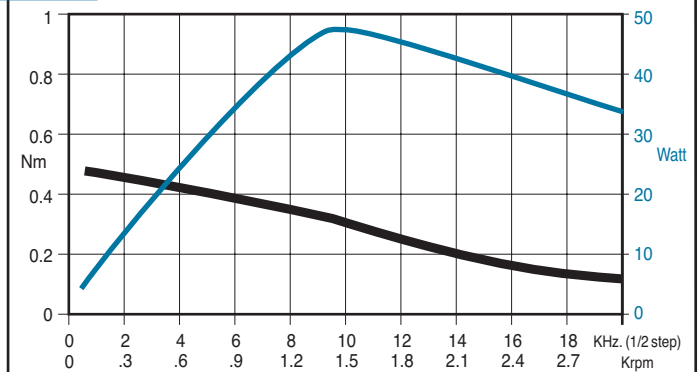

SANYO 103 G770 2241 parallel bipolar connection
RTA GMD02 drive

— torque
— power

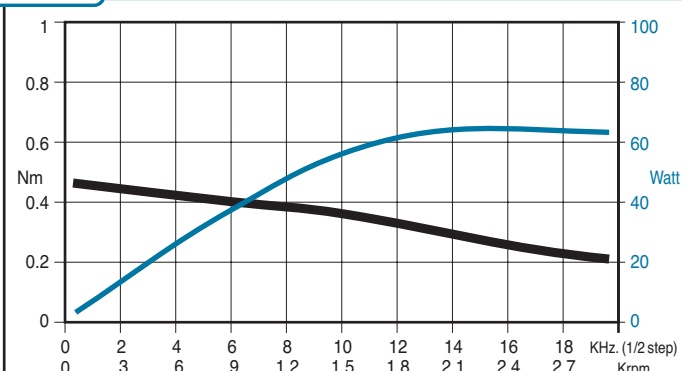

SANYO 103 714 0150
24 Volt, 1.8 Amp. unipolar connection

— torque
— power

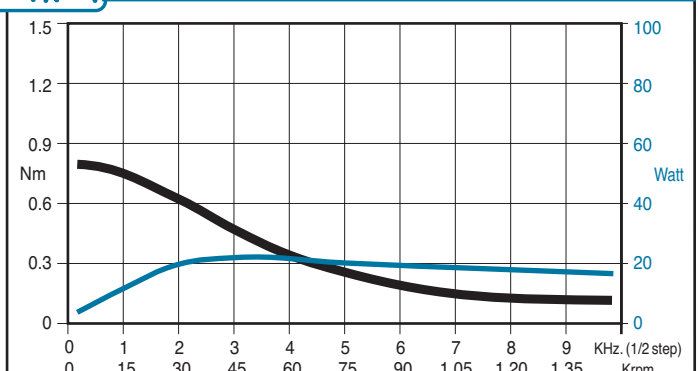

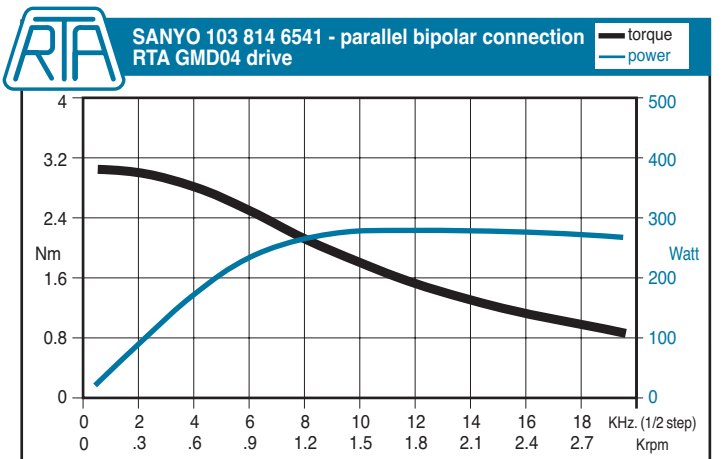
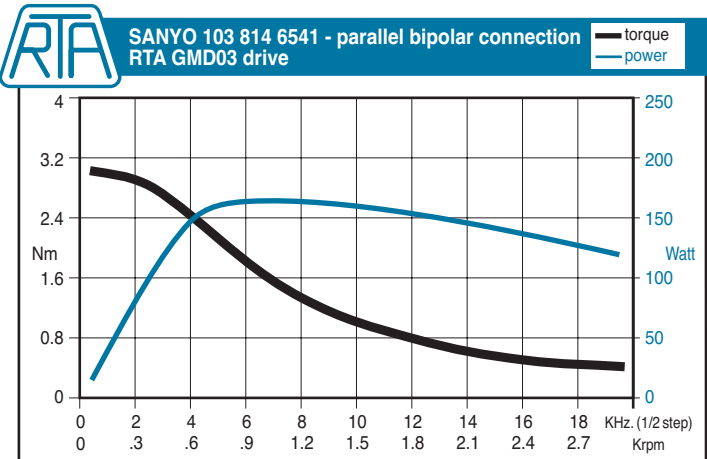
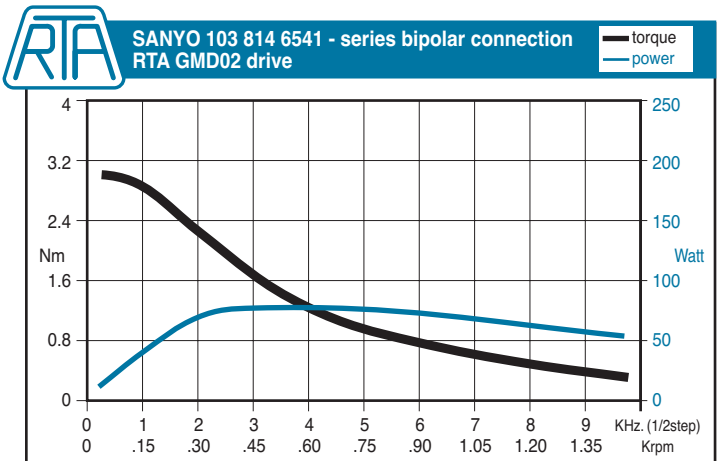
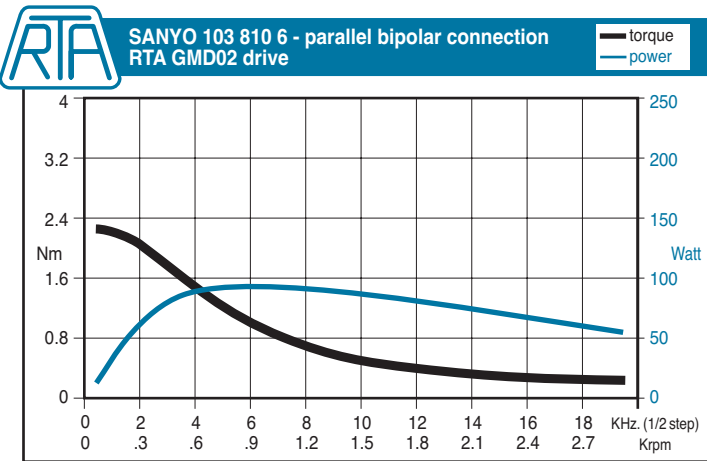
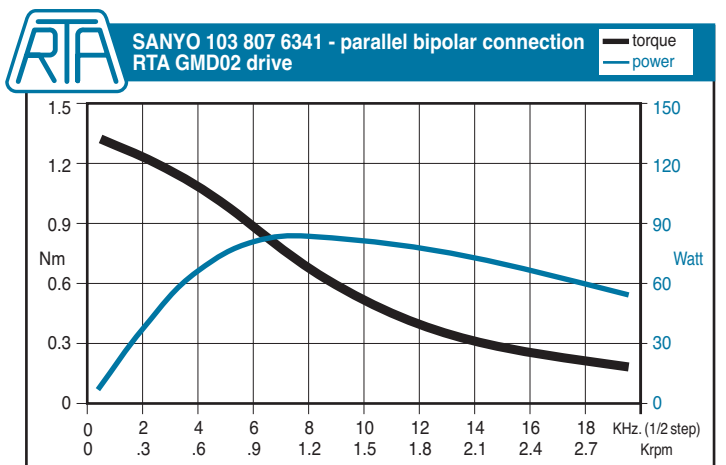
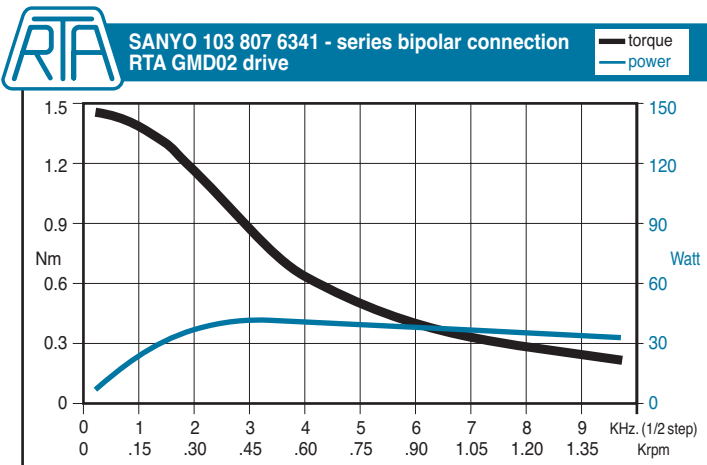
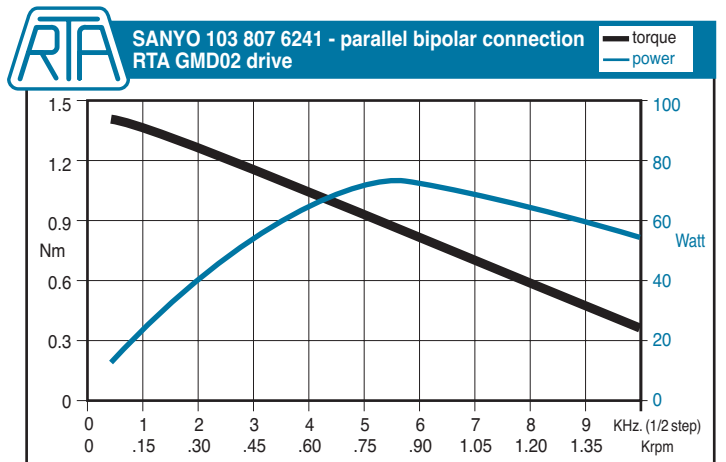
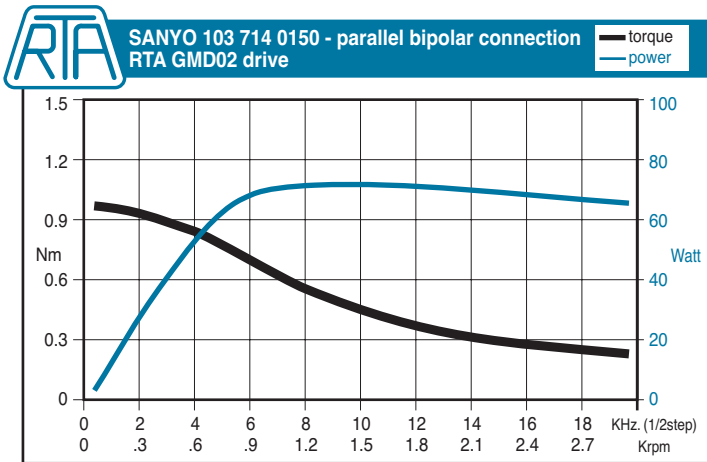

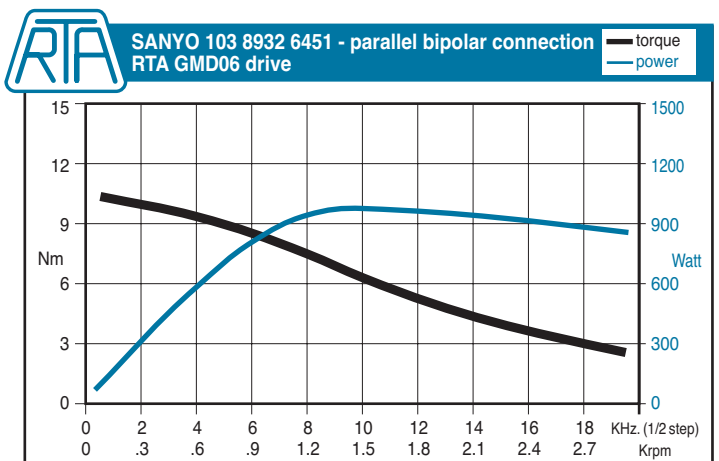
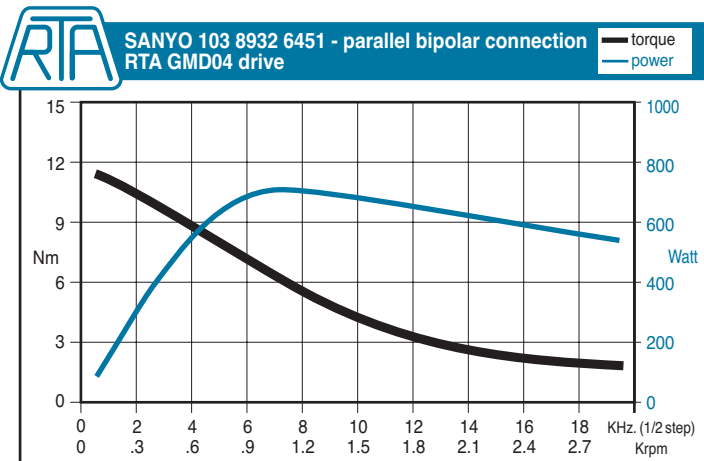
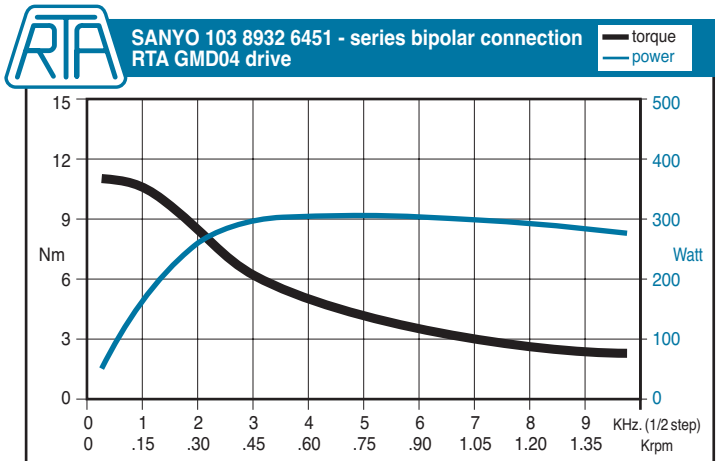
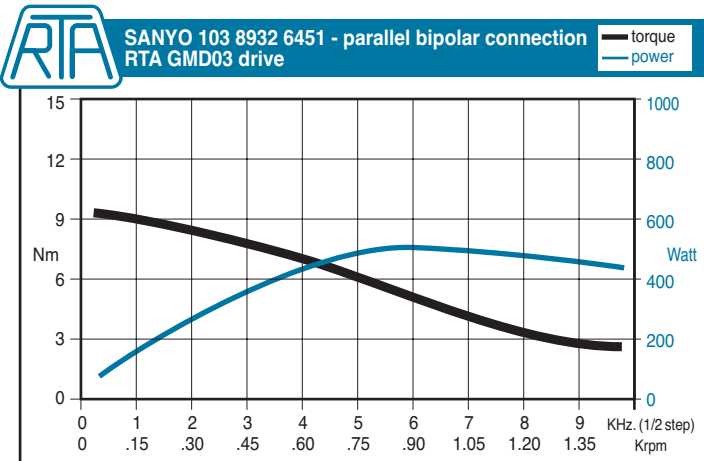
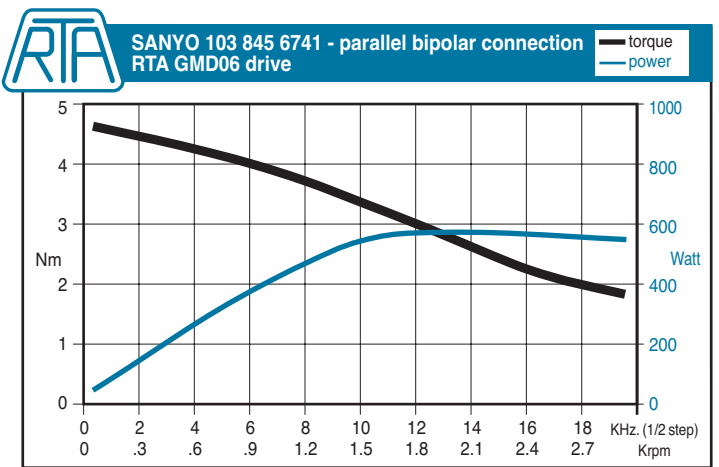
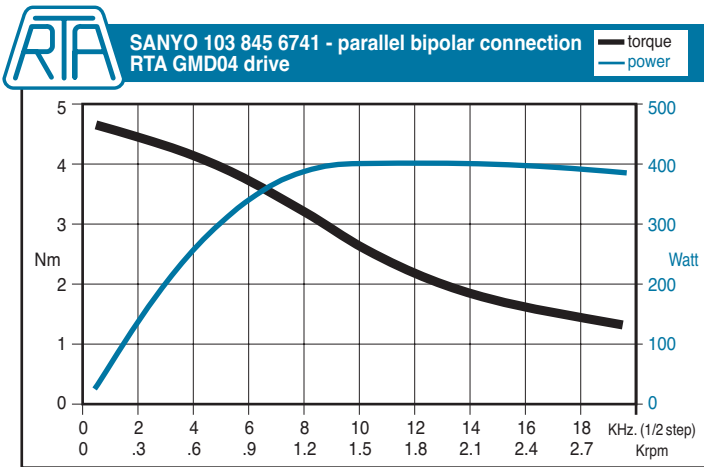
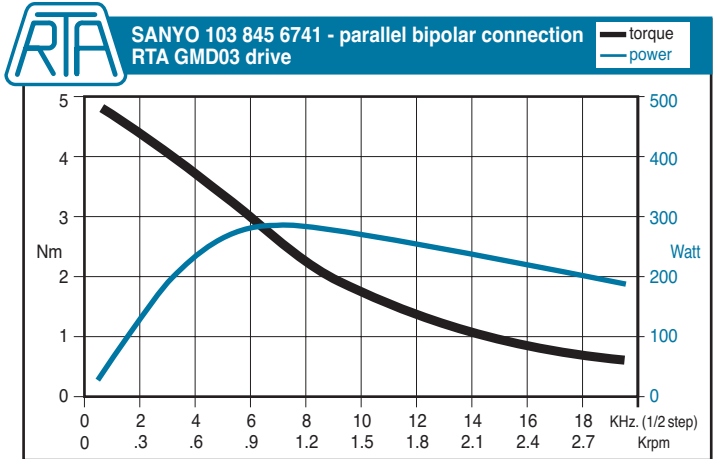
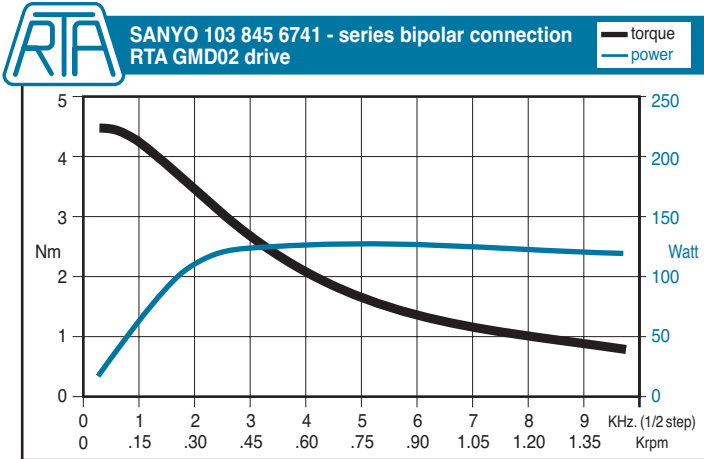

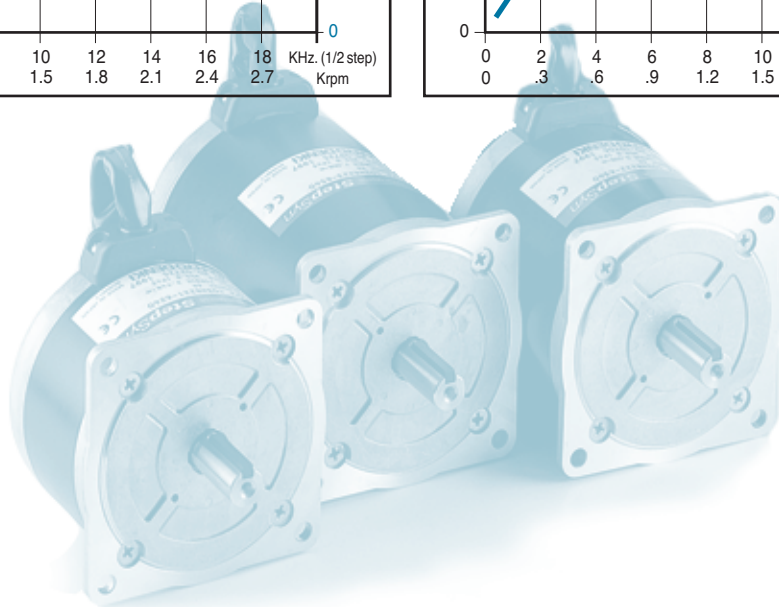
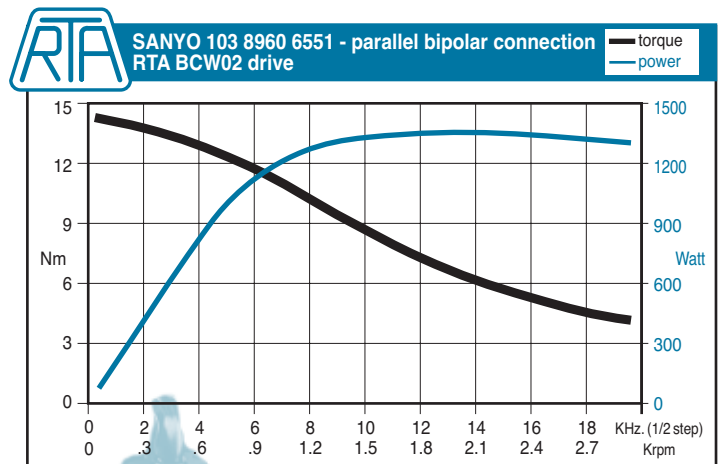
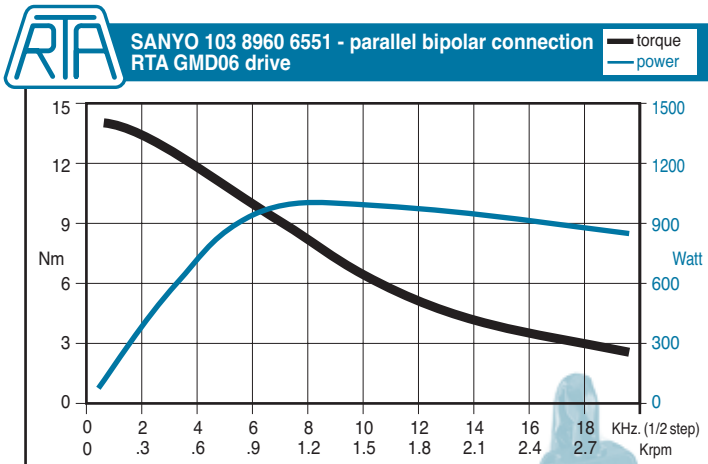
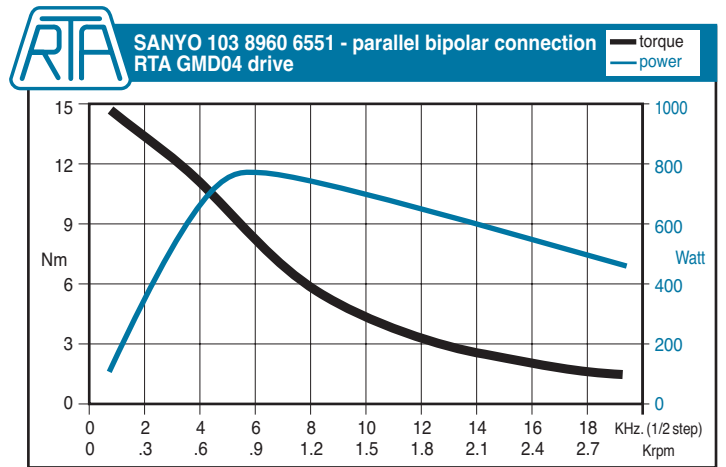
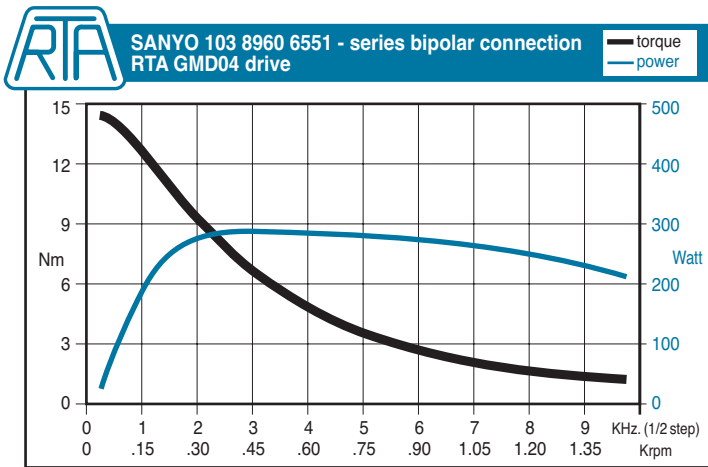
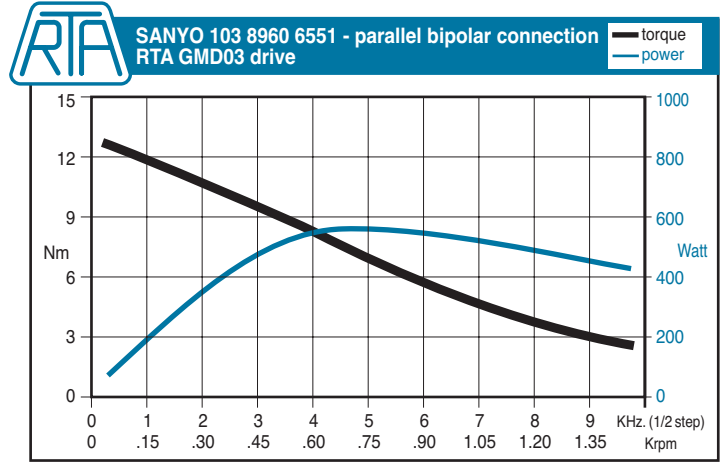
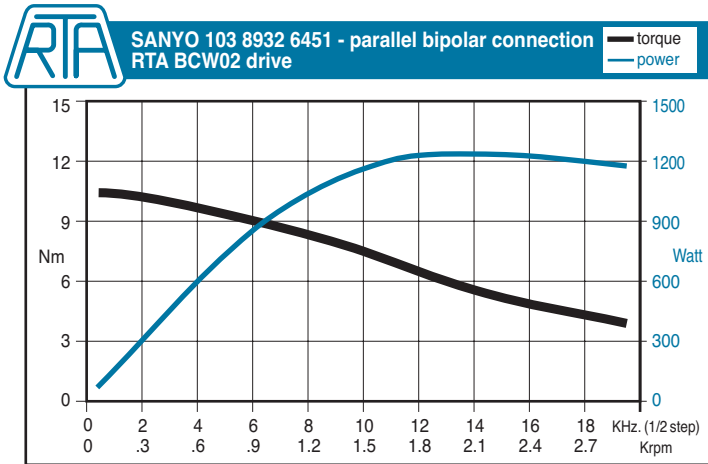



stepping motors, **H Series**

Better torque, small size, high efficiency!

The remarkable commitment of resources invested by SANYO DENKI in the research and development of new technologies and products has allowed it to propose this new range of stepping motors, which go alongside the widest range of standard models.

The innovative design of SANYO DENKI H series stepping motors presents the following advantages, compared with conventional stepping motors:

- Better performance in terms of torque and power, though maintaining conventional standard dimensions (NEMA).
- Lower noise at the same power.
- Less vibrations generated by the motor body.
- Optimized construction for a better exploitation of any advantages in terms of precision and noiselessness offered by high step-fractioning drives.
- Higher efficiency with consequential reduction of losses at the same supplied mechanical power.

The better performance and lower noise make SANYO DENKI H series stepping motors the optimum choice for powerful, precise and reliable positioning systems allowing their use in new fields and applications.



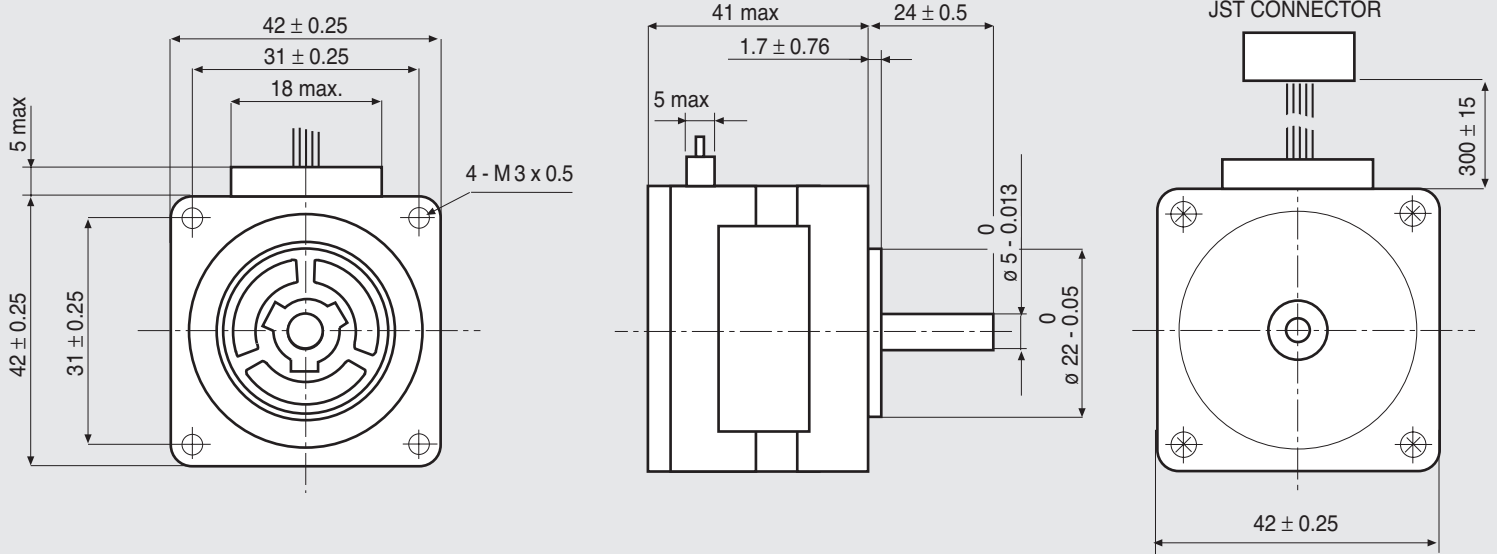

MOTOR CONNECTOR IS JST mod.EHR-6 A 6 POLES FEMALE.
FOR CONNECTION USE JST mod. B6B-EH-A MALE CONNECTOR.

CHARACTERISTICS

MODEL	103 - H548 - 04500
BASIC STEP ANGLE	1.8° ± 0.09°
BIPOLAR CURRENT (Amp)	0.9 ^(*)
UNIPOLAR CURRENT (Amp)	1.2
RESISTANCE (Ohm)	3
INDUCTANCE (mH)	4.3
BIPOLAR HOLDING TORQUE (Ncm)	37
UNIPOLAR HOLDING TORQUE (Ncm)	27
ROTOR INERTIA (Kgm ² x 10 ⁻⁷)	53
THEORETICAL ACCELERATION (rad x sec. ⁻²)	66000
BACK E.M.F. (V/Krpm)	17
MASS (Kg)	0.28
LEADS CODE	IV

(*) Series bipolar connection.

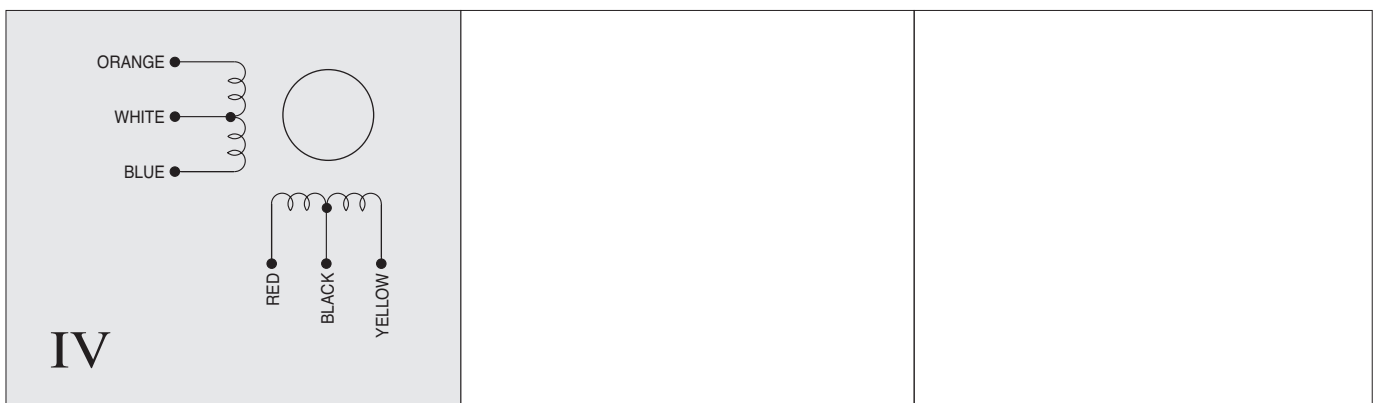

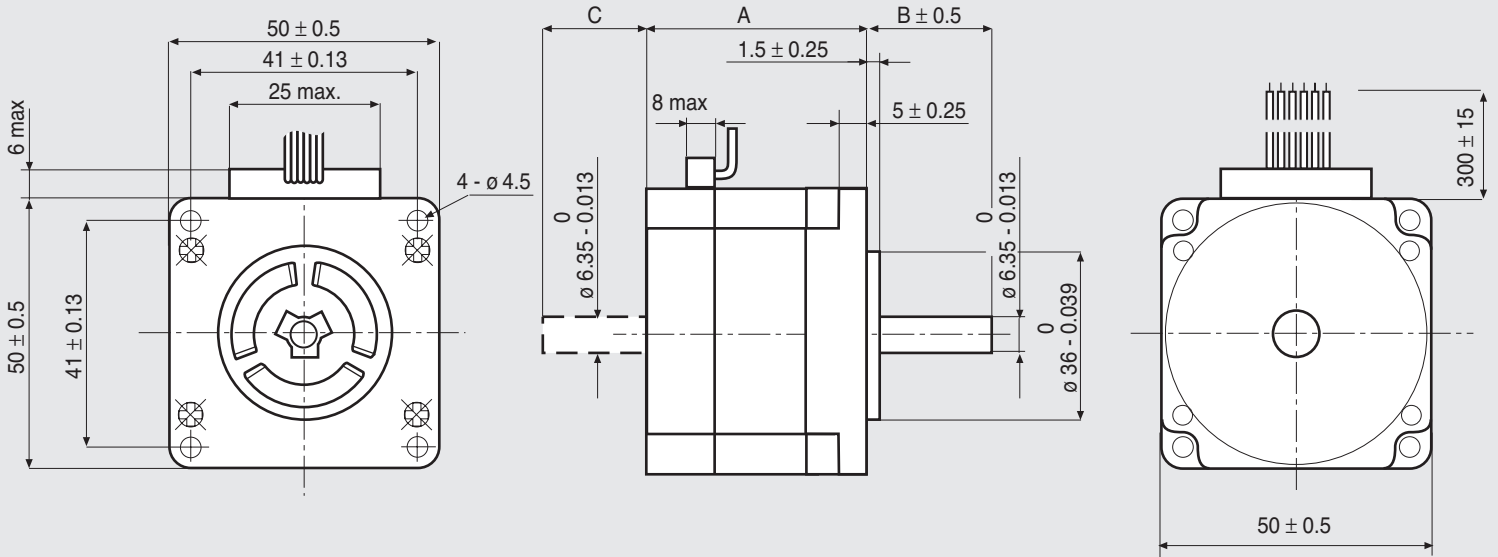

MODEL	A	B	C
103 - H6701 - 0140	39.8	20.6	
103 - H6701 - 0113	39.8	28	15.5
103 - H6703 - 0440	51.3	20.6	

CHARACTERISTICS

MODEL	103 - H6701 - 0140 (103 - H6701 - 0113)	103 - H6703 - 0440
BASIC STEP ANGLE	$1.8^\circ \pm 0.09^\circ$	$1.8^\circ \pm 0.09^\circ$
BIPOLAR CURRENT (Amp)	0.7 ^(*)	1.4 ^(*)
UNIPOLAR CURRENT (Amp)	1.0	2.0
RESISTANCE (Ohm)	4.3	1.6
INDUCTANCE (mH)	6.8	3.2
BIPOLAR HOLDING TORQUE (Ncm)	38	68
UNIPOLAR HOLDING TORQUE (Ncm)	28	49
ROTOR INERTIA (Kg $m^2 \times 10^{-7}$)	57	118
THEORETICAL ACCELERATION (rad x sec. ⁻²)	66000	58000
BACK E.M.F. (V/Krpm)	20	17.5
MASS (Kg)	0.35	0.5
LEADS CODE	IV	IV

Codes between brackets refer to double shaft model.

^(*) Series bipolar connection.

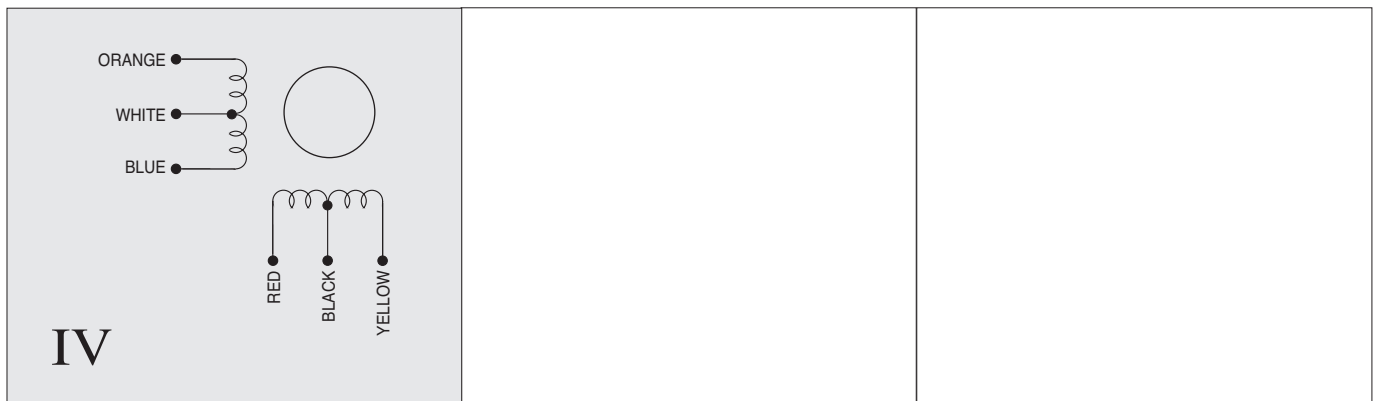

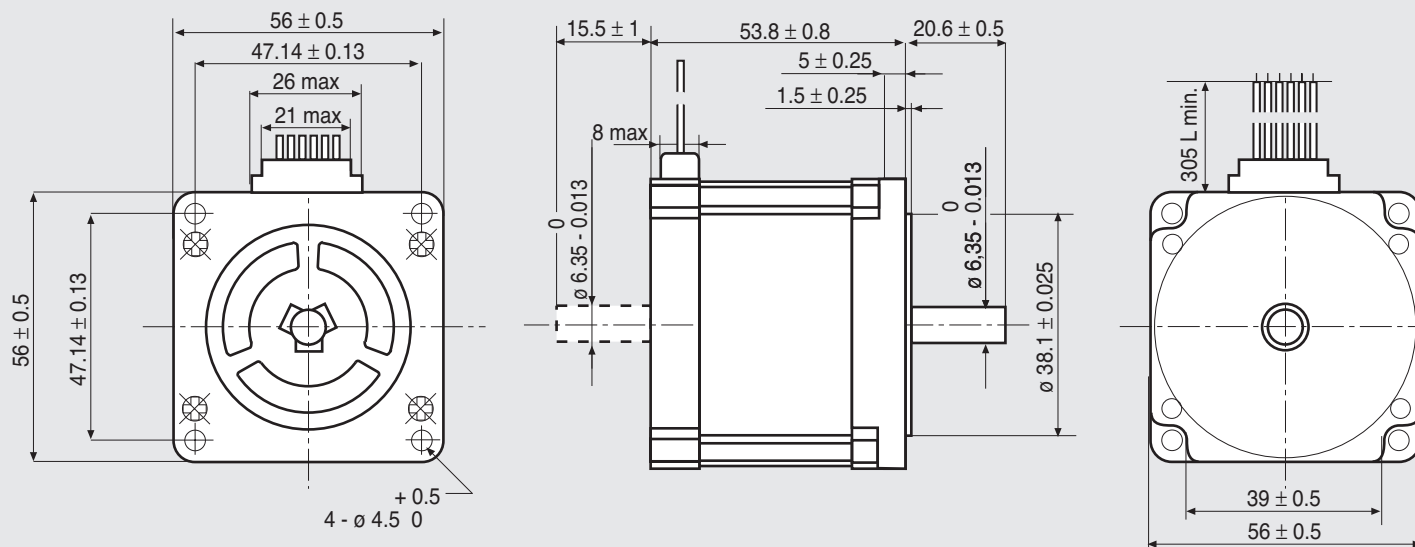

CHARACTERISTICS

MODEL	103-H7123-0140	103-H7123-0440	103-H7123-0740 (103-H7123-0710)	103-H7123-1740 (103-H7123-1710)
BASIC STEP ANGLE	1.8° ± 0.09°	1.8° ± 0.09°	1.8° ± 0.09°	1.8° ± 0.09°
BIPOLAR CURRENT (Amp)	0.7 (*)	1.5 (*)	2.2 (*)	4
UNIPOLAR CURRENT (Amp)	1	2	3	
RESISTANCE (Ohm)	6.7	1.6	0.77	0,41
INDUCTANCE (mH)	15	3.8	1.6	1,6
BIPOLAR HOLDING TORQUE (Ncm)	110	110	110	110
UNIPOLAR HOLDING TORQUE (Ncm)	85	85	85	
ROTOR INERTIA (Kgm ² x 10 ⁻⁷)	210	210	210	210
THEORETICAL ACCELERATION (rad x sec. ⁻²)	50000	50000	50000	50000
BACK E.M.F. (V/Krpm)	60	31	20	20
MASS (Kg)	0.65	0.65	0.65	0,65
LEADS CODE	IV	IV	IV	V

Codes between brackets refer to double shaft model.

(*) Series bipolar connection.

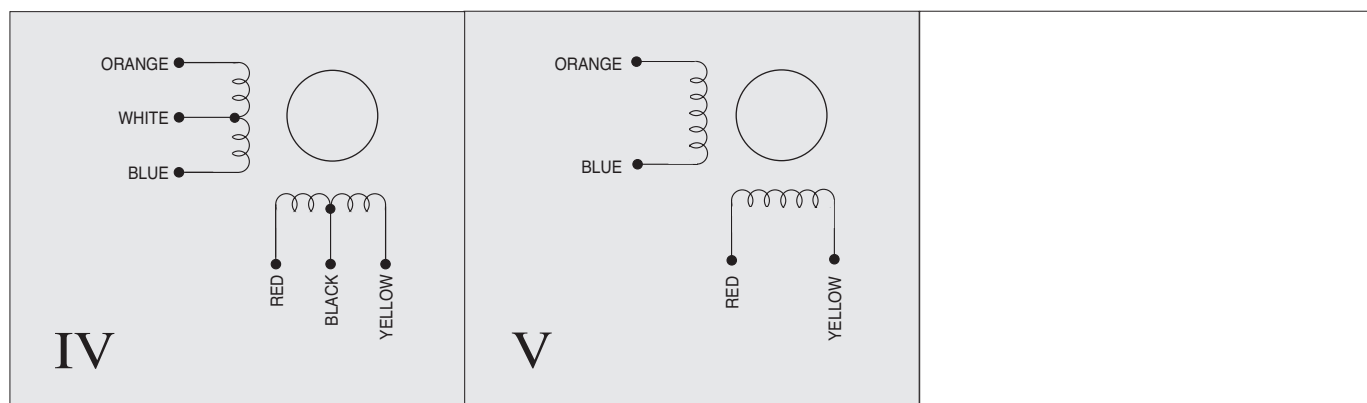

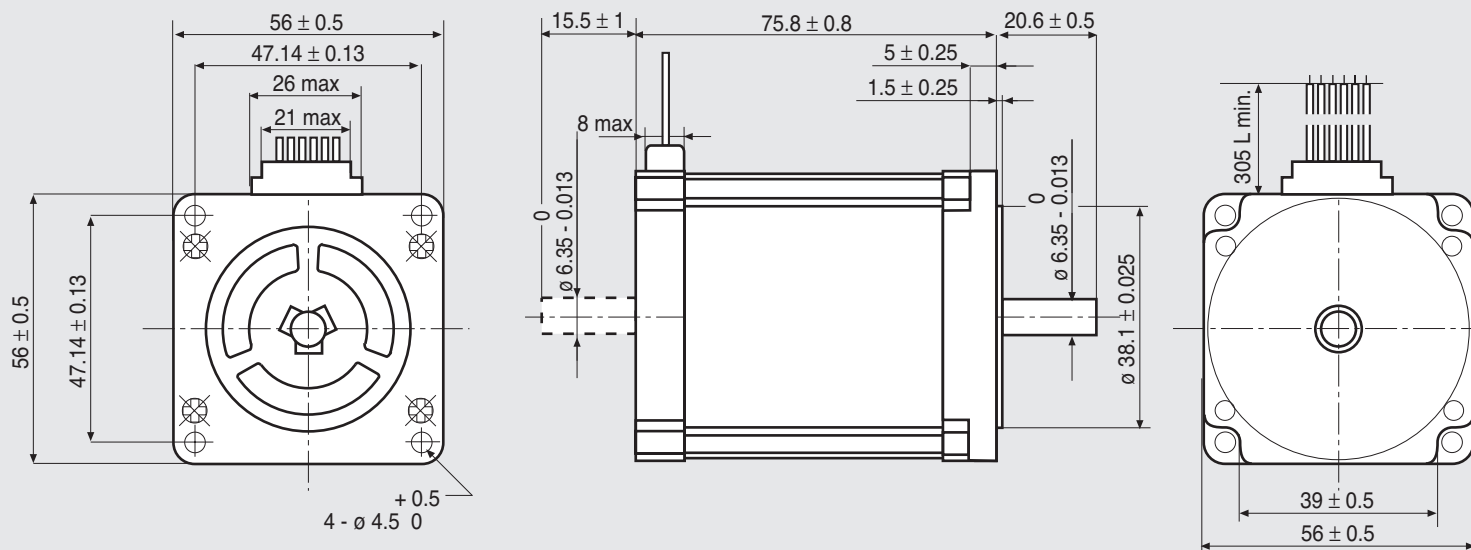

CHARACTERISTICS

MODEL	103 - H7126 - 0140	103 - H7126 - 0740 (103 - H7126 - 0710)	103 - H7126 - 1740 (103 - H7126 - 1712)
BASIC STEP ANGLE	1.8° ± 0.09°	1.8° ± 0.09°	1.8° ± 0.09°
BIPOLAR CURRENT (Amp)	0.75 (*)	2.2 (*)	4
UNIPOLAR CURRENT (Amp)	1	3	
RESISTANCE (Ohm)	8.6	0.9	0.48
INDUCTANCE (mH)	19	2.2	2.2
BIPOLAR HOLDING TORQUE (Ncm)	165	165	165
UNIPOLAR HOLDING TORQUE (Ncm)	130	130	
ROTOR INERTIA (Kgm ² x 10 ⁻⁷)	360	360	360
THEORETICAL ACCELERATION (rad x sec. ⁻²)	45800	45800	45800
BACK E.M.F. (V/Krpm)	92	31	31
MASS (Kg)	1	1	1
LEADS CODE	IV	IV	V

Codes between brackets refer to double shaft model.

(*) Series bipolar connection.

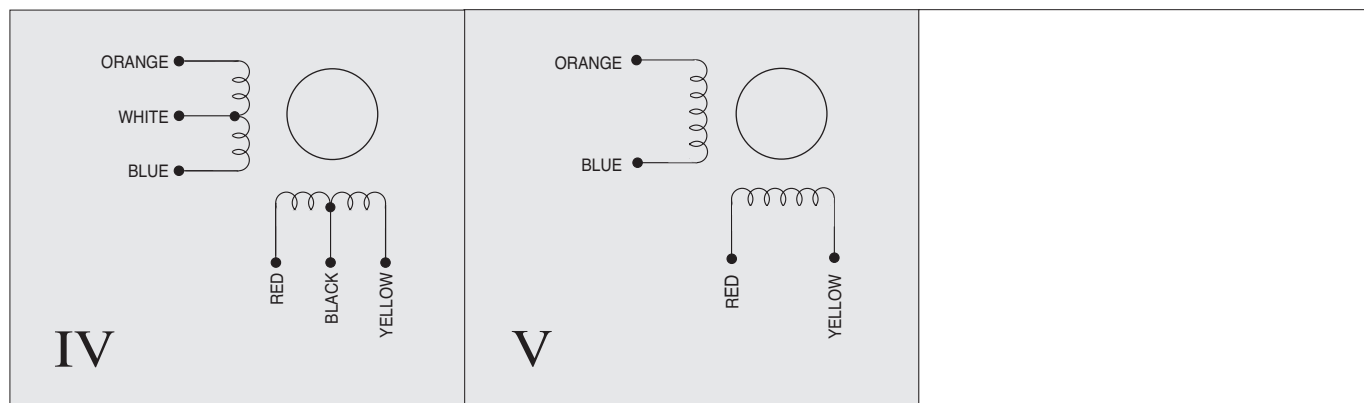

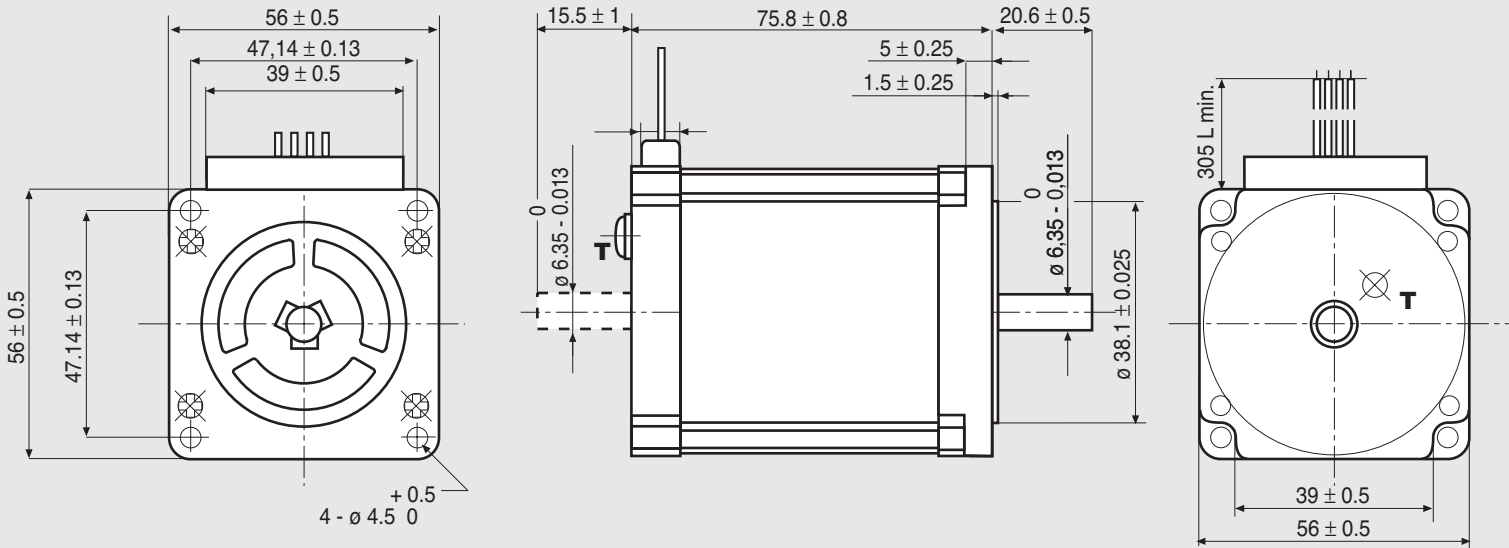

T IS THE EARTH TERMINAL.

CHARACTERISTICS

MODEL	103 - H7126 - 6640 (103 - H7126 - 6610)
BASIC STEP ANGLE	1.8° ± 0.09°
BIPOLAR CURRENT (Amp)	5.6
RESISTANCE (Ohm)	0.3
INDUCTANCE (mH)	0.85
BIPOLAR HOLDING TORQUE (Ncm)	165
ROTOR INERTIA (Kgm ² x 10 ⁻⁷)	360
THEORETICAL ACCELERATION (rad x sec. ⁻²)	45800
BACK E.M.F. (V/Krpm)	23
MASS (Kg)	1
PROTECTION DEGREE	IP43
LEADS CODE	V

Codes between brackets refer to double shaft model.

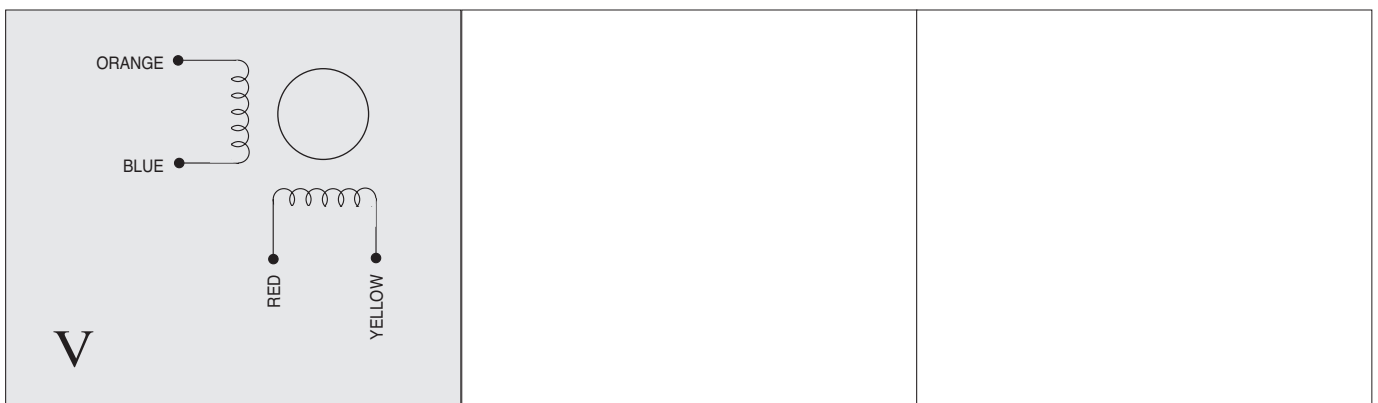

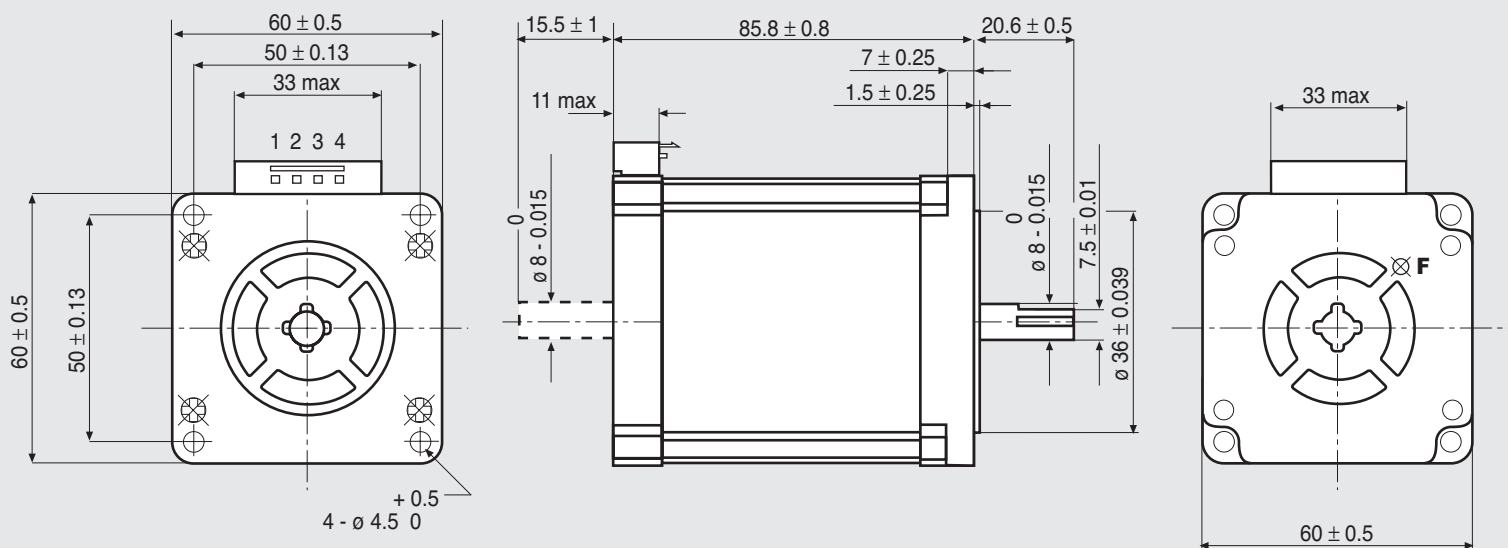

MOTOR CONNECTOR IS JST mod. B4P-VH 4 POLES MALE.
FOR CONNECTION USE JST mod. VHR-4N FEMALE CONNECTOR AND mod. SVH-21T-P1.1 CONTACTS.

FOR **F** THREADED HOLE USE 3x6 mm SCREWS.

CHARACTERISTICS

MODEL	103 - H7823 - 1741 (103 - H7823 - 1711)
BASIC STEP ANGLE	1.8° ± 0.09°
BIPOLAR CURRENT (Amp)	4.0
RESISTANCE (Ohm)	0.65
INDUCTANCE (mH)	2.4
BIPOLAR HOLDING TORQUE (Ncm)	300
ROTOR INERTIA (Kgm ² x 10 ⁻⁷)	840
THEORETICAL ACCELERATION (rad x sec. ⁻²)	35700
BACK E.M.F. (V/Krpm)	75
MASS (Kg)	1.4
LEADS CODE	V

Codes between brackets refer to double shaft model.

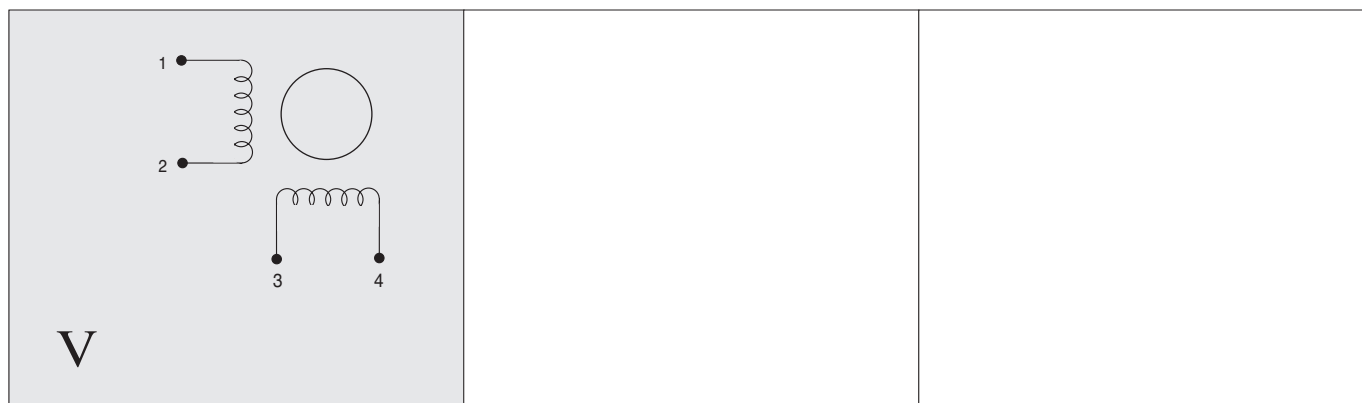

SANYO DENKI *Step-Syn* 103 - H8222 - 63XE42 SERIES

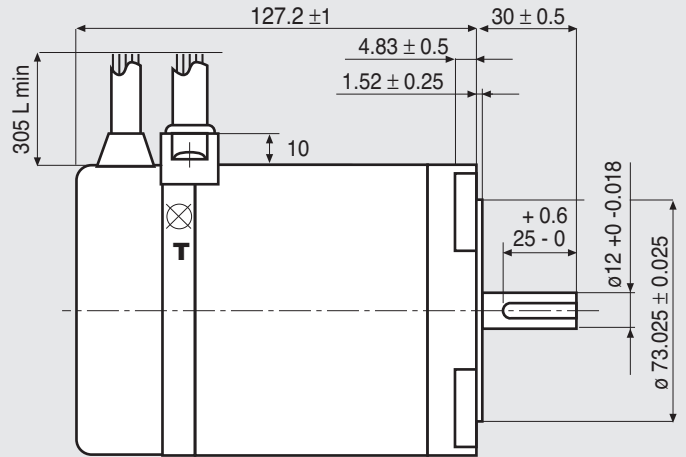
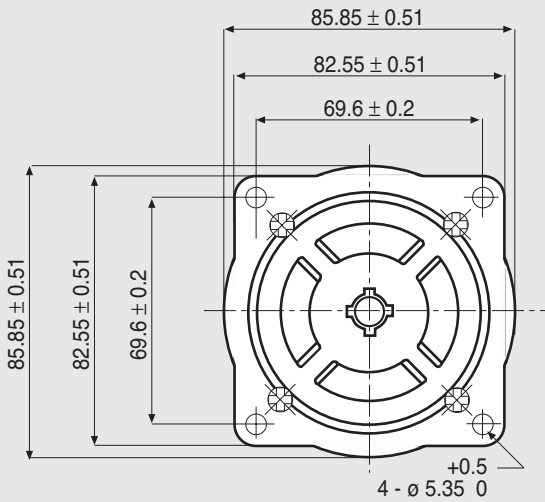

WIRES ARE HOUSED IN A VINYL TUBE.
T IS THE EARTH TERMINAL

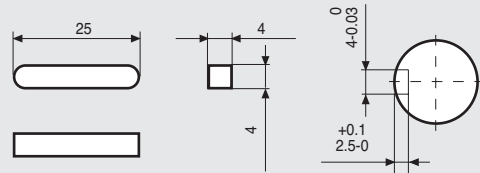

CHARACTERISTICS

MODEL	103 - H8222 - 63XE42	
BASIC STEP ANGLE	1.8° ± 0.09°	
BIPOLAR CURRENT	(Amp)	6
RESISTANCE	(Ohm)	0.35
INDUCTANCE	(mH)	2.7
BIPOLAR HOLDING TORQUE	(Ncm)	560
ROTOR INERTIA	(Kgm ² x 10 ⁻⁷)	2900
THEORETICAL ACCELERATION	(rad x sec. ⁻²)	19300
BACK E.M.F.	(V/Krpm)	93
MASS	(Kg)	2.8
PROTECTION DEGREE	IP40	
ENCODER CHARACTERISTICS	Line Driver 5 Vdc 200 step/rev.	
LEADS CODE	V	

Codes between brackets refer to double shaft model.

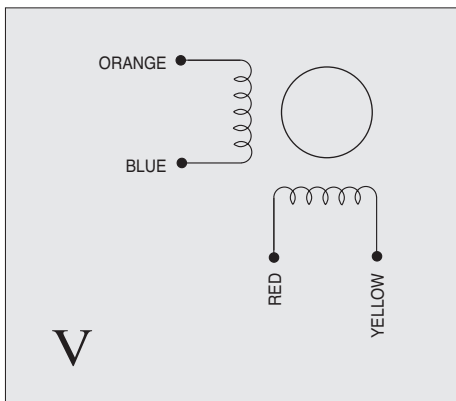

LEADS COLOR	ENCODER
BLUE	CHANNEL A
BROWN	CHANNEL \bar{A}
GREEN	CHANNEL B
PURPLE	CHANNEL \bar{B}
WHITE	CHANNEL C
YELLOW	CHANNEL \bar{C}
RED	±5Volt
BLACK	0Volt
BLACK	FG (SHIELD)

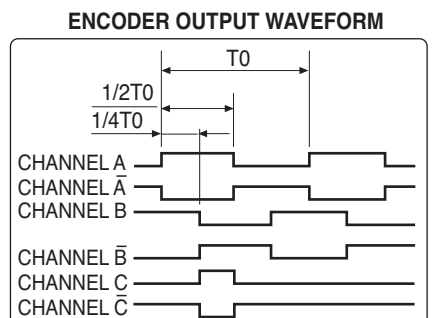

With this waveform the shaft rotation is counterclockwise when view from mounting surface side. F max 100 KHz.

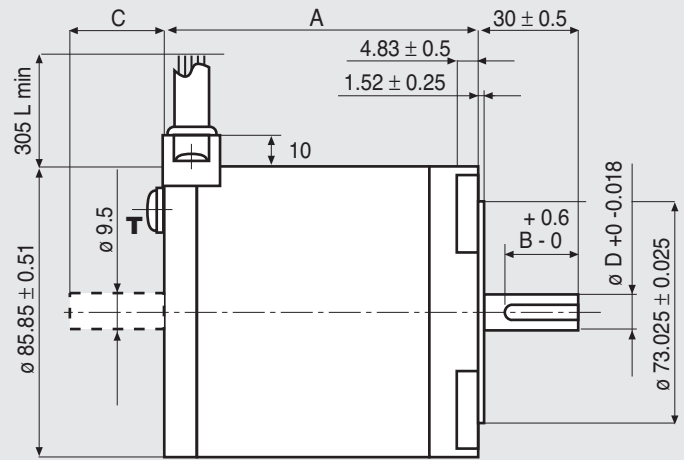
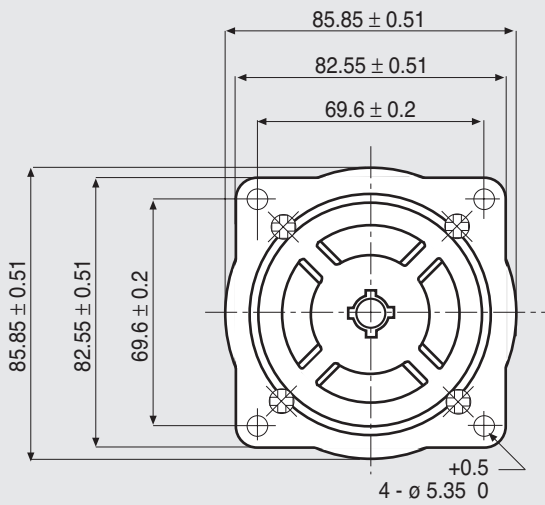

WIRES ARE HOUSED IN A VINYL TUBE.
T IS THE EARTH TERMINAL

MODEL	A	B	C	D
103 - H8221 - 6241	62	22		9.525
103 - H8221 - 6211	62	22	25.4±0,5	9.525
103 - H8222 - 6340	92.2	25		12
103 - H8222 - 6310	92.2	25	28±1	12
103 - H8223 - 6540	125.9	25		12
103 - H8223 - 6510	125.9	25	28±1	12

CHARACTERISTICS

MODEL	103 - H8221 - 6241 (103 - H8221 - 6211)	103 - H8222 - 6340 (103 - H8222 - 6310)	103 - H8223 - 6540 (103 - H8223 - 6510)
BASIC STEP ANGLE	1,8° ± 0,09°	1,8° ± 0,09°	1,8° ± 0,09°
BIPOLAR CURRENT (Amp)	6	6	9
RESISTANCE (Ohm)	0.3	0.35	0.2
INDUCTANCE (mH)	1.65	2.7	1.4
BIPOLAR HOLDING TORQUE (Ncm)	300	560	790
ROTOR INERTIA (Kgm ² x 10 ⁻⁷)	1450	2900	4350
THEORETICAL ACCELERATION (rad x sec. ⁻²)	20600	19300	18200
BACK E.M.F. (V/Krpm)	50	93	88
MASS (Kg)	1.5	2.5	3.5
PROTECTION DEGREE	IP43	IP43	IP43
LEADS CODE	V	V	V

Codes between brackets refer to double shaft model.

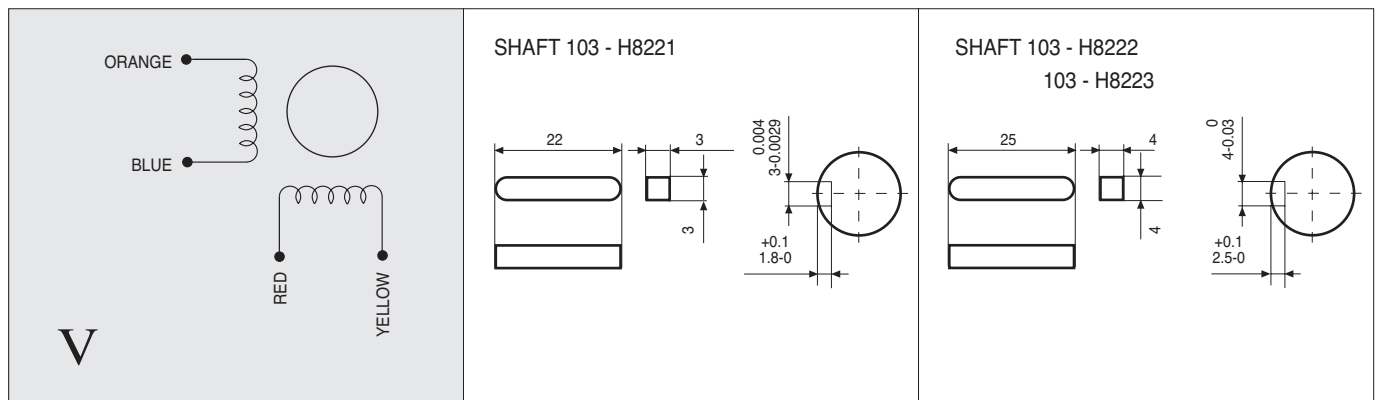

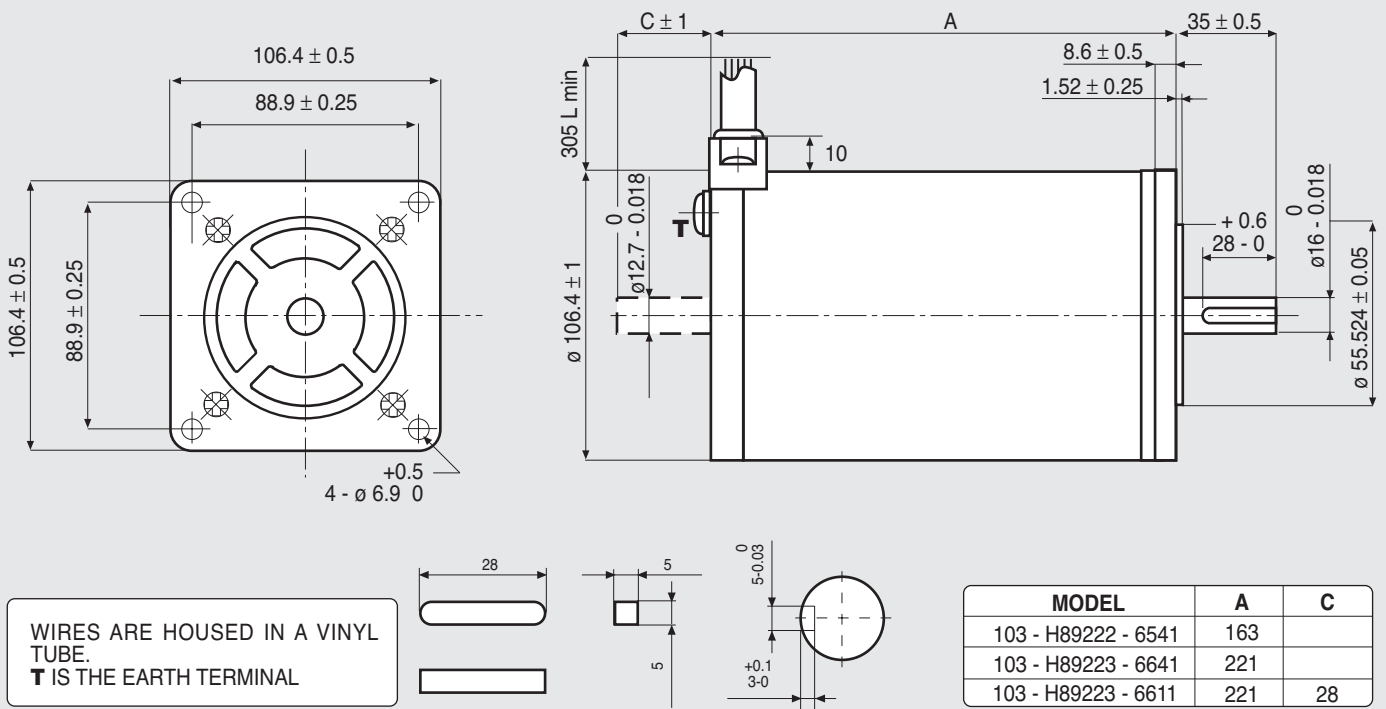

CHARACTERISTICS

MODEL	103 - H89222 - 6541	103 - H89223 - 6641 (103 - H89223 - 6611)
BASIC STEP ANGLE	1.8° ± 0.09°	1.8° ± 0.09°
BIPOLAR CURRENT (Amp)	10	12
RESISTANCE (Ohm)	0.16	0.16
INDUCTANCE (mH)	1.9	2
BIPOLAR HOLDING TORQUE (Ncm)	1620	2460
ROTOR INERTIA (Kgm ² x 10 ⁻⁷)	14650	22000
THEORETICAL ACCELERATION (rad x sec. ⁻²)	11100	11100
BACK E.M.F. (V/Krpm)	162	205
MASS (Kg)	7	10
PROTECTION DEGREE	IP43	IP43
LEADS CODE	V	V

Codes between brackets refer to double shaft model.

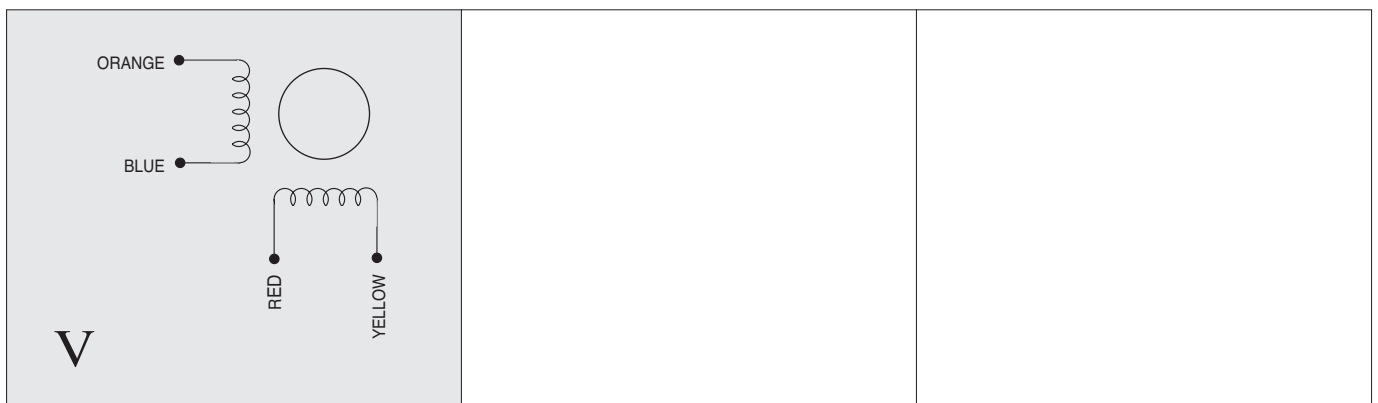

The correct dimensioning of a stepping motor system requires a deep knowledge of the two following essential parameters:

- Mechanical features of the application, as for example inertia of masses in motion, transmission kinematics, speed, acceleration, time required to perform the motion, duty cycle etc.
- Performances of the motor-drive unit, mainly in terms of torque-speed curves.

The torque is not only a feature of the sole motor, but is strongly affected by the drive used with it. The same motor can be used with various drive types in order to obtain different performances in different applications.

Hereafter are reported a selection table and some typical Torque-Speed diagrams obtained with different couplings between RTA drives and SANYO motors. For a correct interpretation of these information, the following considerations apply:

- All reported curves are “pull-out curves”
- Couplings indicated in the selection table take into account only the compatibility between the motor and the power output characteristics of the drive. The effective choice must be made only knowing all requirements of the application like resolution, type of supply, mechanical format etc. (for more information about drive characteristics see also Drive manual)
- At very low speed (<30 RPM) resonance and vibration, strongly dependent by load, could appear with “non ministep-drives” (HGD, GMD, GAC, BCW). This phenomenon is much less critical with “ministep drives” (SDC, SAC, GMH, MIND)
- As the majority of the stepping motor systems, most of the indicated couplings exhibit duty cycle limitations in order to avoid motor overheating. Accessories like motor heatsinks and/or fans are available in case of need
- In the selection table, “**YT**” means that, for this coupling the specific torque-speed diagram is present; “**Y**” means that the coupling is rated but the specific torque-speed diagram is not present. For a specific motor, the use of the same background colour in different couplings with different drives means that all those couplings exhibit similar torque-speed characteristics. This means that, when you have a motor with one coupling marked “**YT**” and three couplings marked “**Y**” with the same background colour, you can use the torque-speed diagram shown for “**YT**” also for the other three.



SELECTION TABLE FOR COUPLING BETWEEN STANDARD MOTORS AND DRIVES

MOTOR MODELS AND CONNECTIONS		DRIVE MODELS	HGD		SDC/SAC			GMH				GMD				GAC		MIND			BCW
			04	06	04	05	06	05	06	07	09	02	03	04	06	03	04	...3	...4	...5	02
H548-04500	Parallel*	YT		Y																	
H548-04500	Series	YT		Y																	
H6701-0140	Parallel*	YT		Y																	
H6701-0140	Series	YT		Y																	
H6703-0440	Parallel*	YT		Y																	
H6703-0440	Series	YT		Y																	
H7123-0740	Series		Y		Y		Y				YT										
H7123-1740	—		Y			Y		Y			YT										
H7126-0740	Series		Y		Y		Y				YT										
H7126-1740	—		Y			Y		Y			YT				Y						
H7126-6640	—		Y			Y		Y			YT				Y						
H7823-1741	—		Y			Y		Y			YT				Y						
H8221-6241	—		Y			Y		Y			YT		YT		Y	Y	Y	Y			
H8222-6340	—							Y			YT		YT		Y	Y	Y	Y			
H8223-6540	—								Y	YT		YT	YT	Y	Y	Y	Y	Y	Y		
H89222-6541	—								Y	YT		YT	YT	Y	Y	Y	Y	Y	Y	Y	YT
H89223-6641	—								Y	YT		YT	YT	Y	Y	Y	Y	Y	Y	Y	YT

* 6-wires motor. For Parallel connection see page 32.



SANYO 103 H548 04500 - parallel bipolar connection - RTA HGD04 drive

— torque
— power

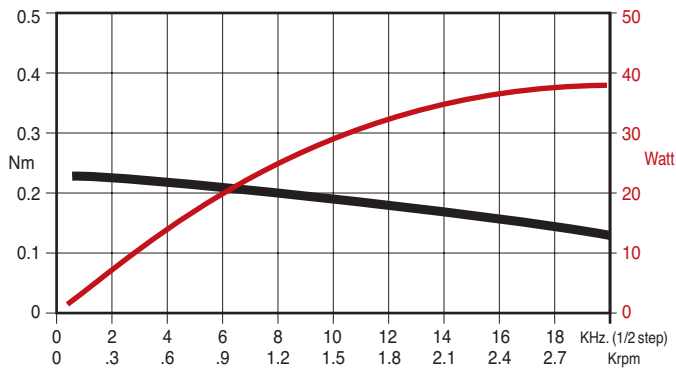

SANYO 103 H548 04500 - series bipolar connection - RTA HGD04 drive

— torque
— power

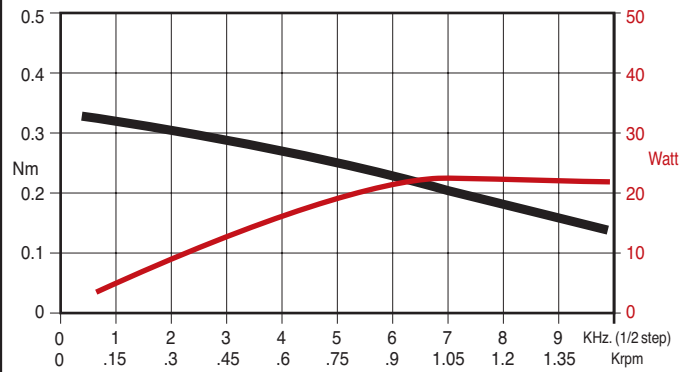

SANYO 103 H6701 0140 - parallel bipolar connection - RTA HGD04 drive

— torque
— power

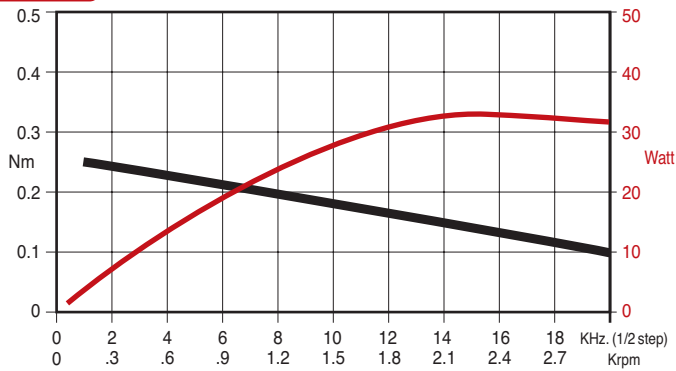

SANYO 103 H6701 0140 - series bipolar connection - RTA HGD04 drive

— torque
— power

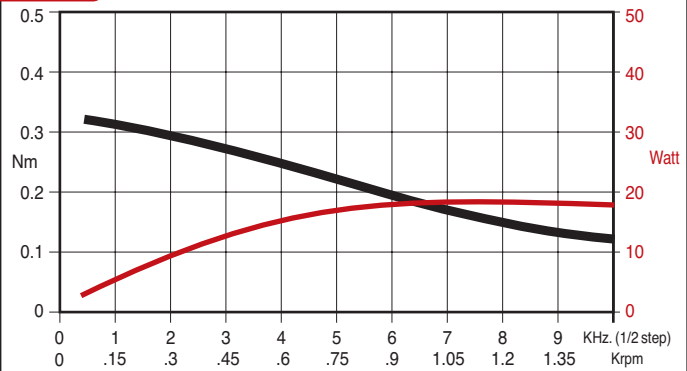

SANYO 103 H6703 0440 - parallel bipolar connection - RTA HGD04 drive

— torque
— power

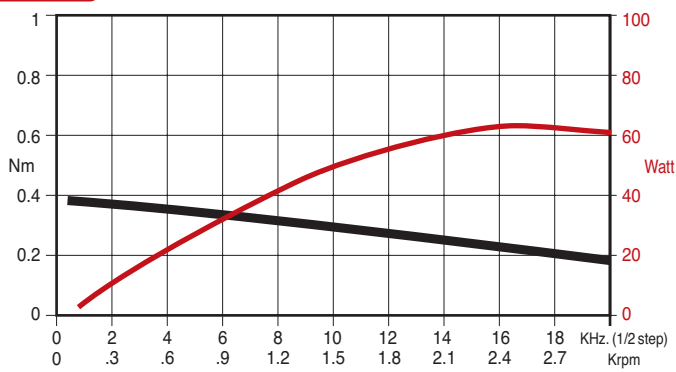

SANYO 103 H6703 0440 - series bipolar connection - RTA HGD04 drive

— torque
— power

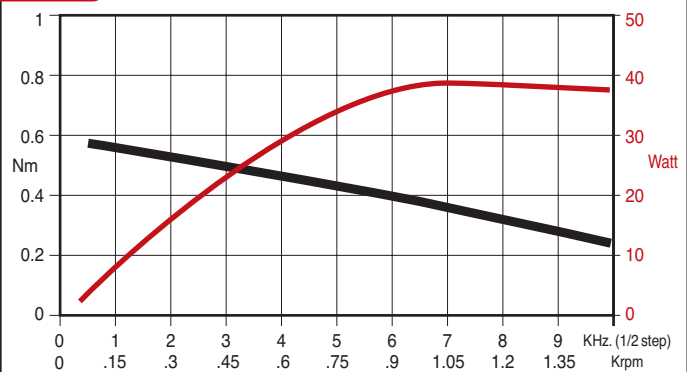

103 H7123 0140
24 Volt, 1 Amp. unipolar connection

— torque
— power

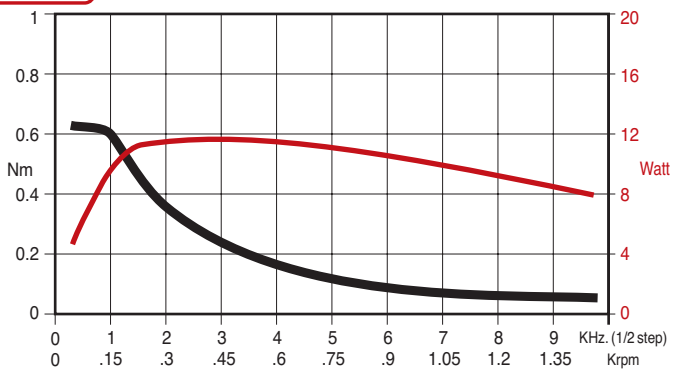

SANYO 103 H7123 0740 - series bipolar connection - RTA GMD02 drive

— torque
— power

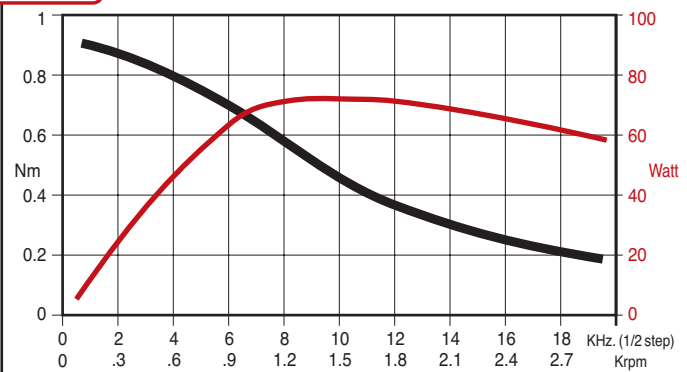



SANYO 103 H7123 1740 - bipolar connection
RTA GMD02 drive

— torque
— power

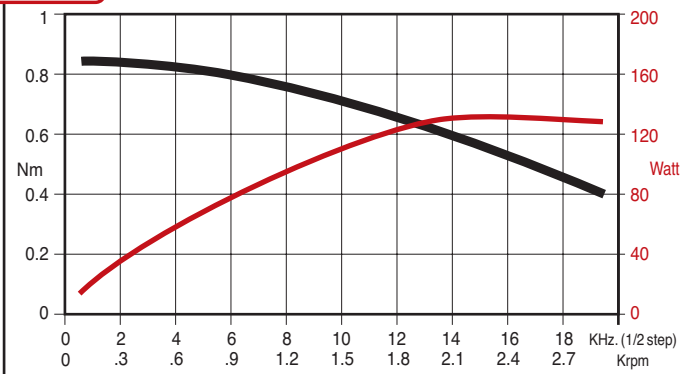

SANYO 103 H7126 0140
24 Volt, 1 Amp. unipolar connection

— torque
— power

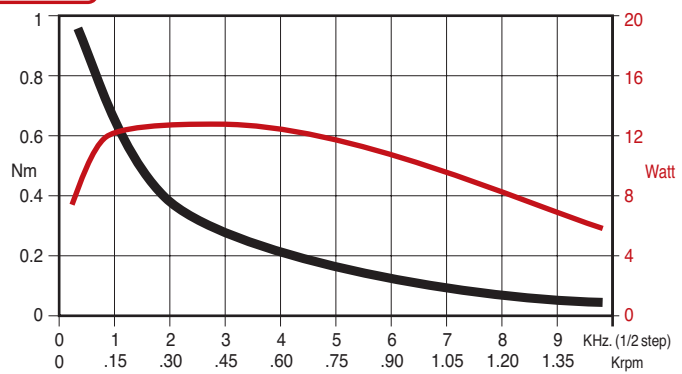

SANYO 103 H7126 0740 - series bipolar connection
RTA GMD02 drive

— torque
— power

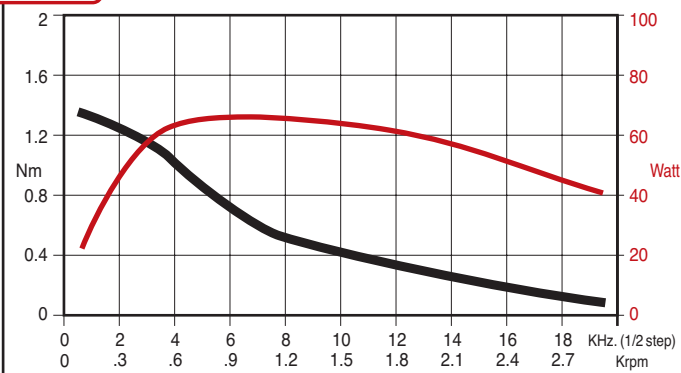

SANYO 103 H7126 1740 - bipolar connection
RTA - GMD02 drive

— torque
— power

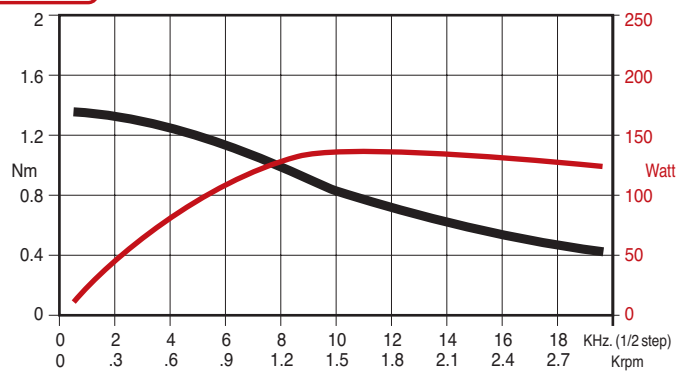

SANYO 103 H7126 6640 - bipolar connection
RTA GMD02 drive

— torque
— power

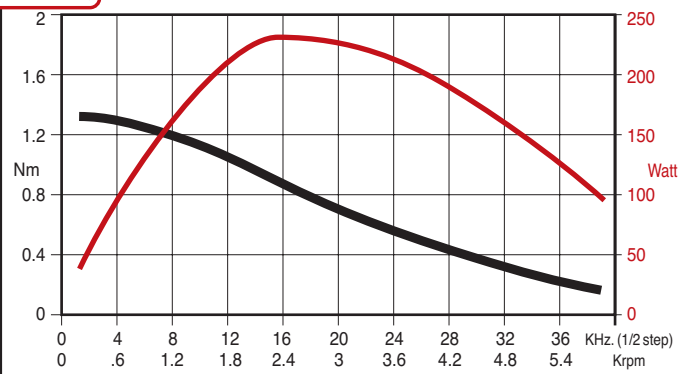

SANYO 103 H7823 1741 - bipolar connection
RTA GMD02 drive

— torque
— power

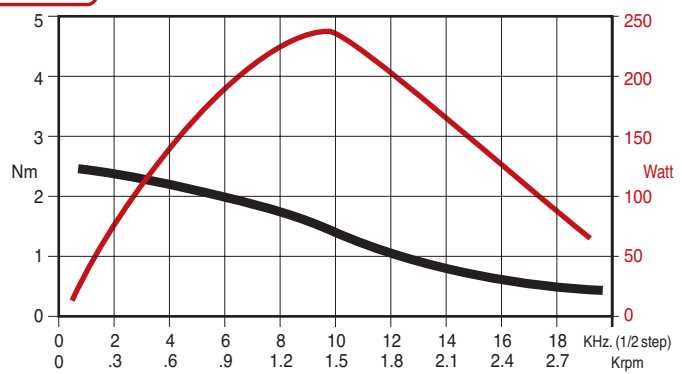

SANYO 103 H8221 6241 - bipolar connection
RTA GMD02 drive

— torque
— power

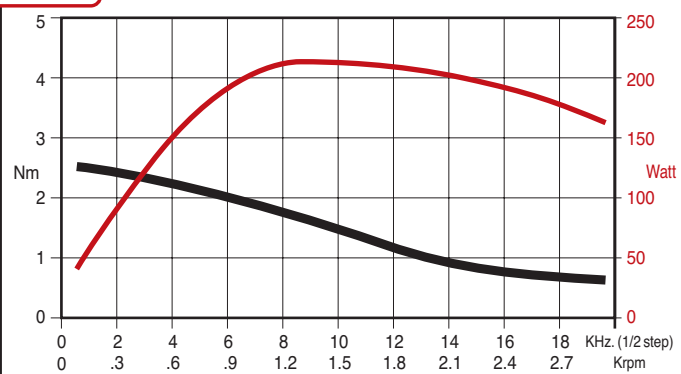

SANYO 103 H8221 6241 - bipolar connection
RTA GMD04 drive

— torque
— power

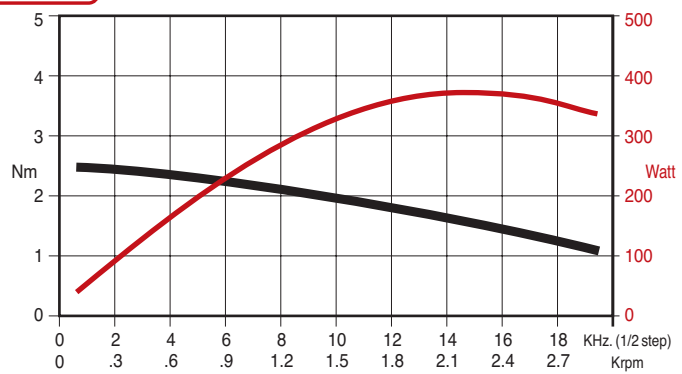

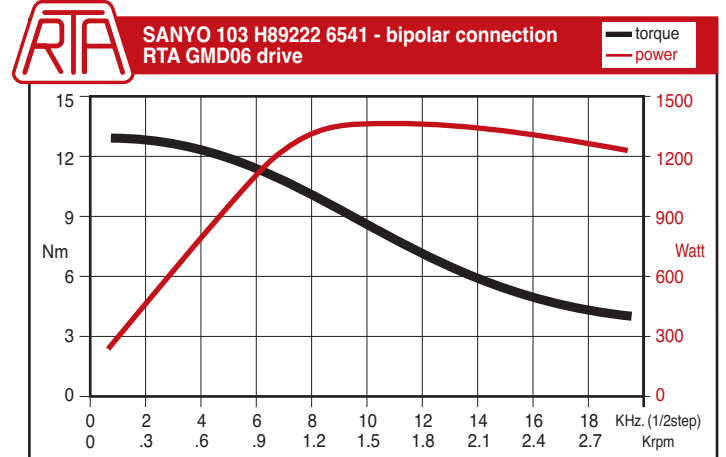
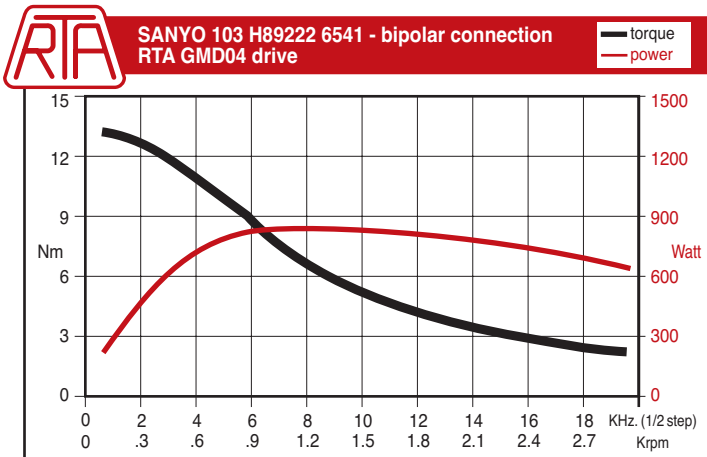
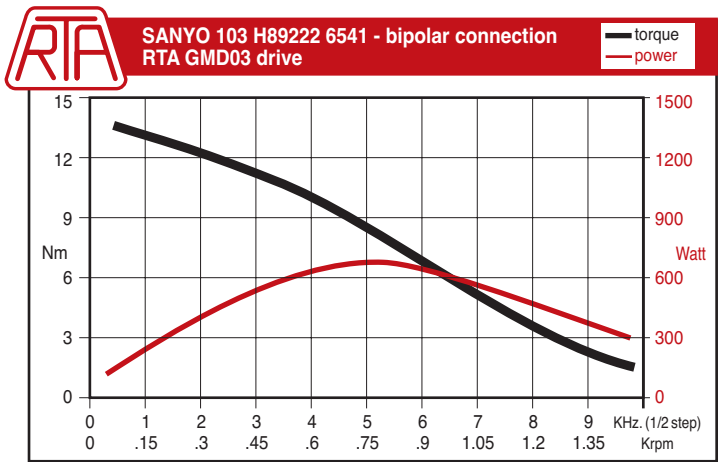
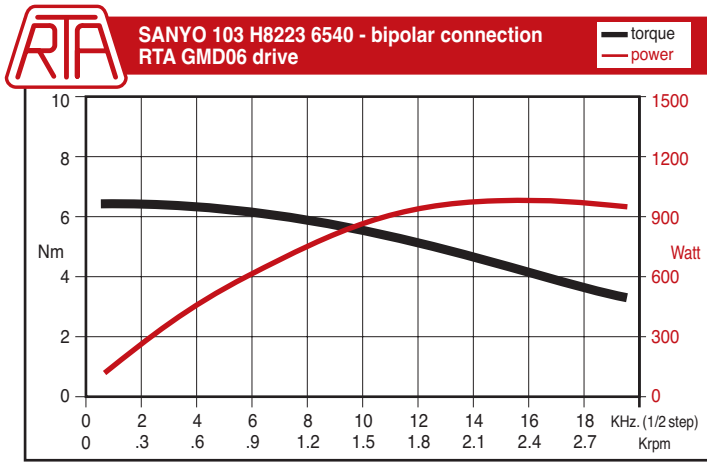
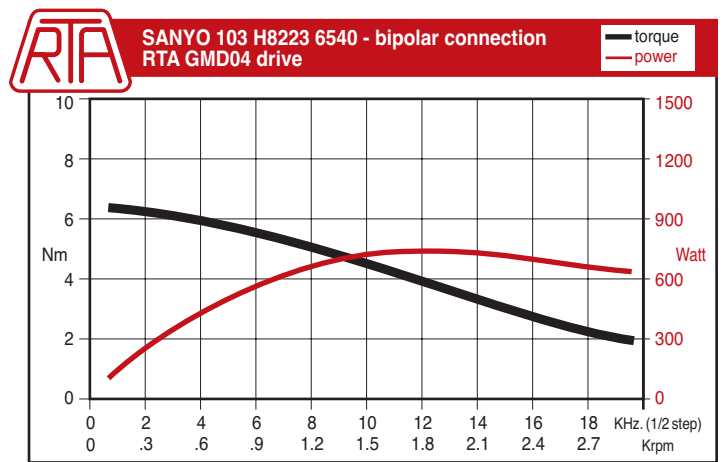
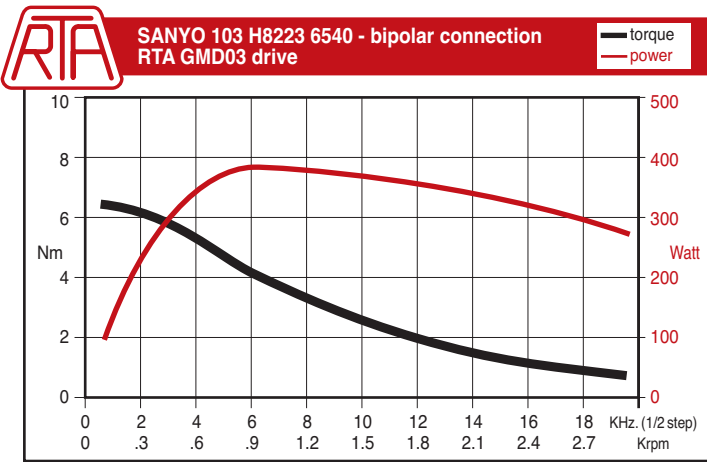
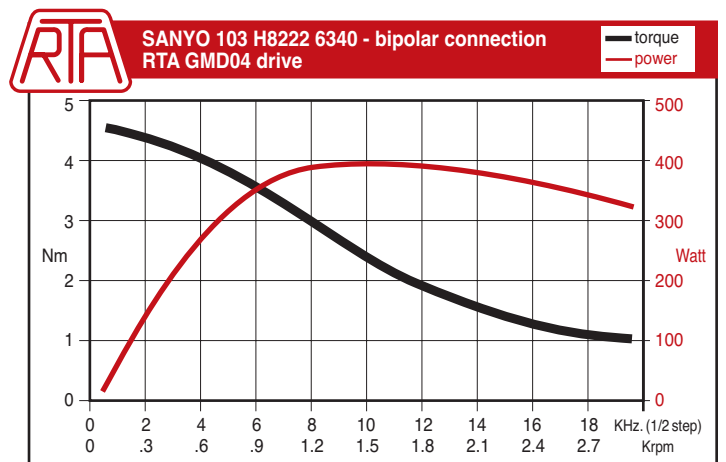
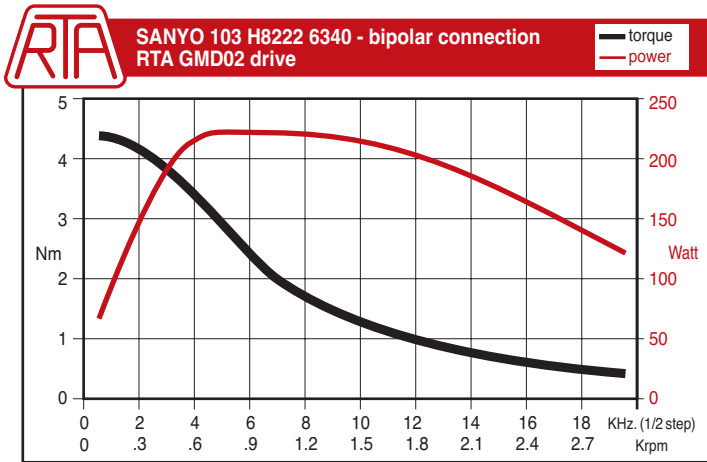

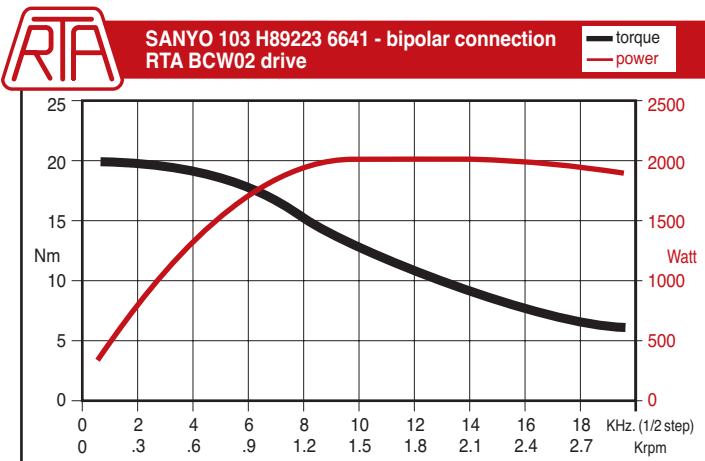
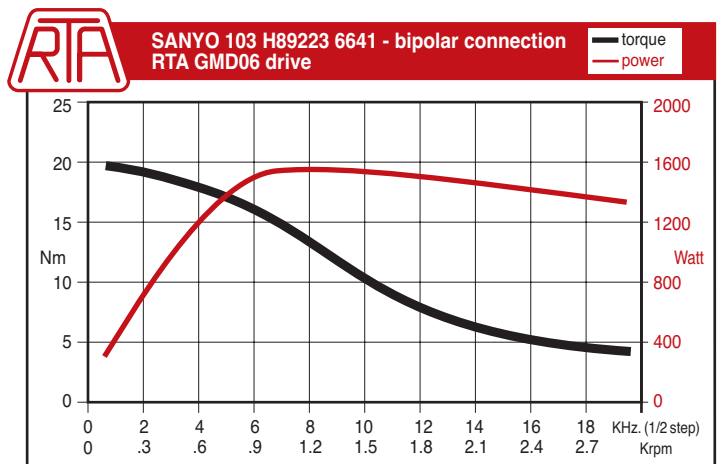
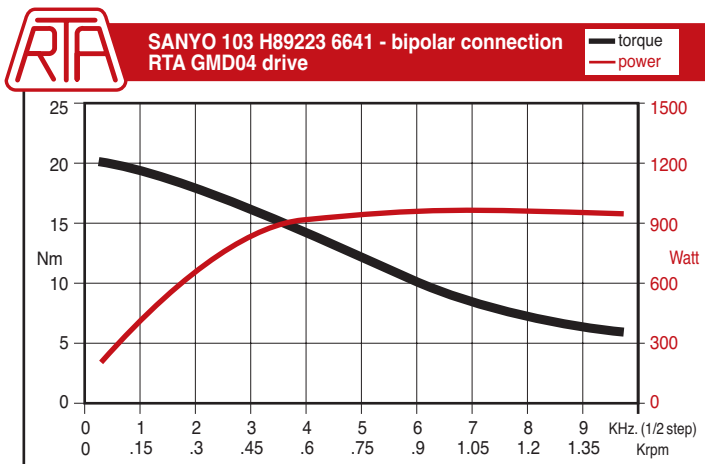
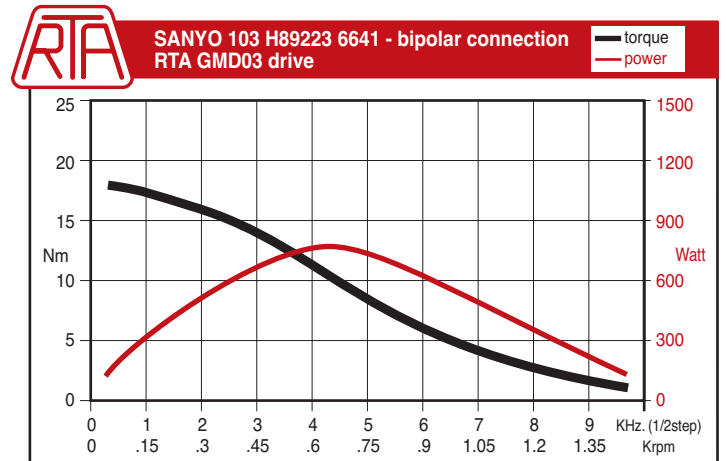
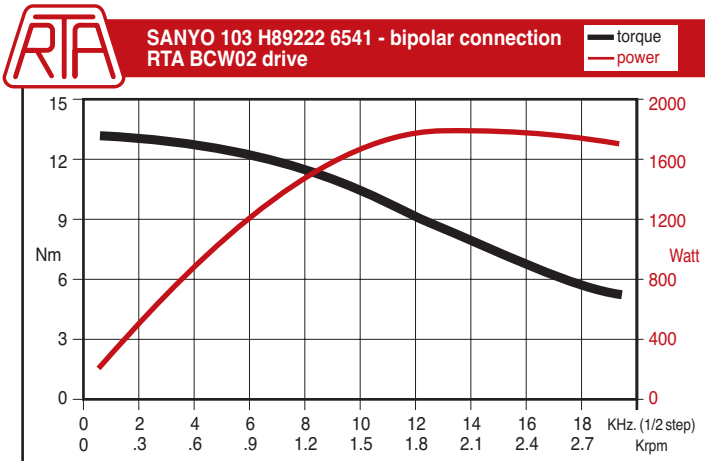

CONVERSION FACTORS

LENGTH 1 mm = 3.937×10^{-2} inch

MASS 1 Kg = 2.205 x lb force

INERTIA $10^7 \text{ g cm}^2 = 1 \text{ Kg m}^2 = 5.467 \times 10^4 \text{ oz in}^2 = 3.417 \times 10^3 \text{ lb in}^2$

TORQUE 1 Nm = $1.416 \times 10^2 \text{ oz in} = 0.738 \text{ ft lb} = 8.85 \text{ in lb}$
1 Ncm = $1.416 \text{ oz in} = 7.38 \times 10^{-3} \text{ ft lb} = 8.85 \times 10^{-2} \text{ in lb}$

POWER 1 KW = 1.34 hp
1 W = $1.34 \times 10^{-3} \text{ hp}$

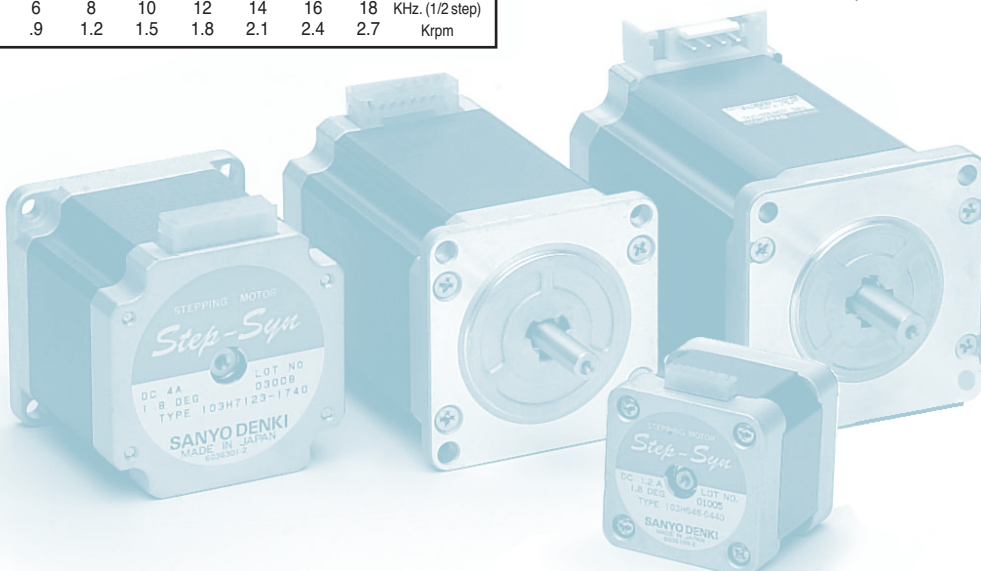

LEADS
CODE

PARALLEL BIPOLAR
CONNECTION

SERIES BIPOLAR
CONNECTION

UNIPOLAR
CONNECTION

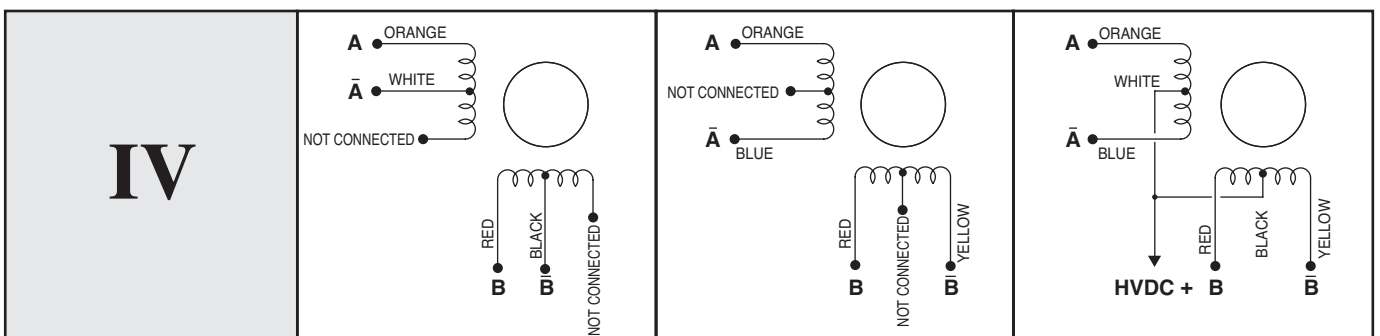
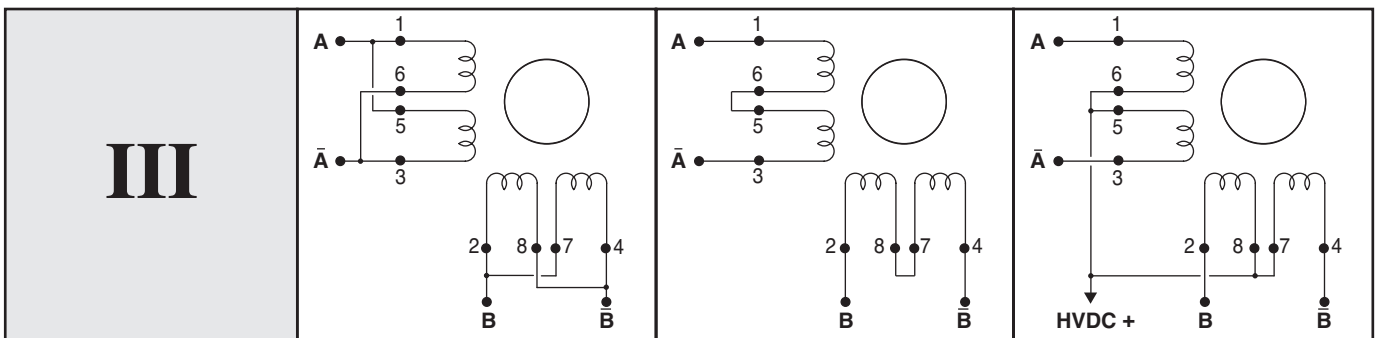
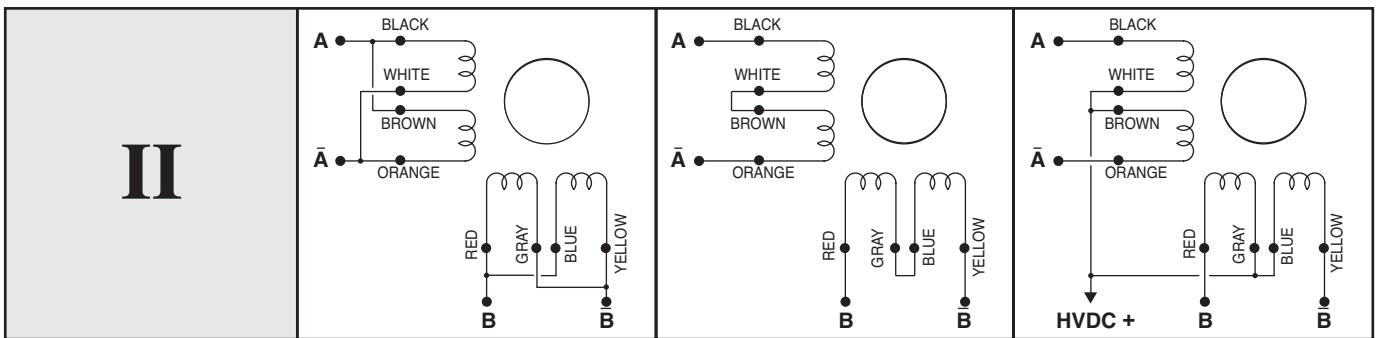
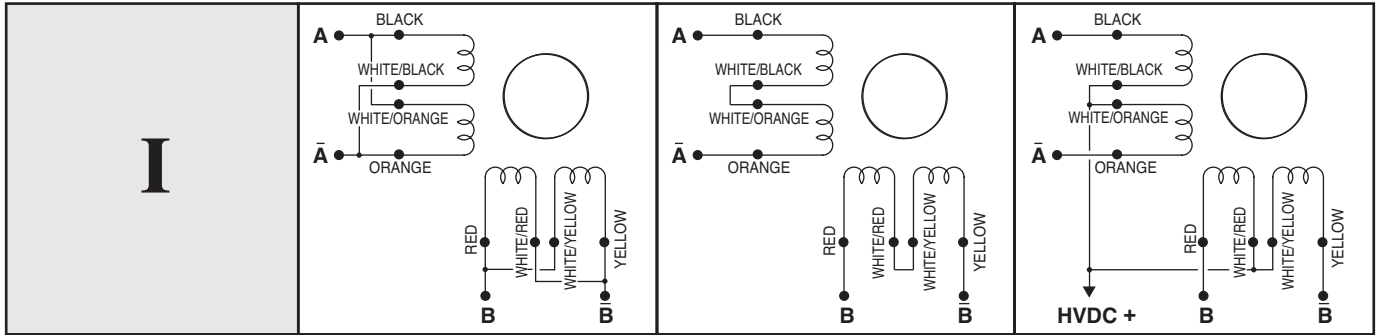

LEADS
CODE

PARALLEL BIPOLAR
CONNECTION

SERIES BIPOLAR
CONNECTION

UNIPOLAR
CONNECTION

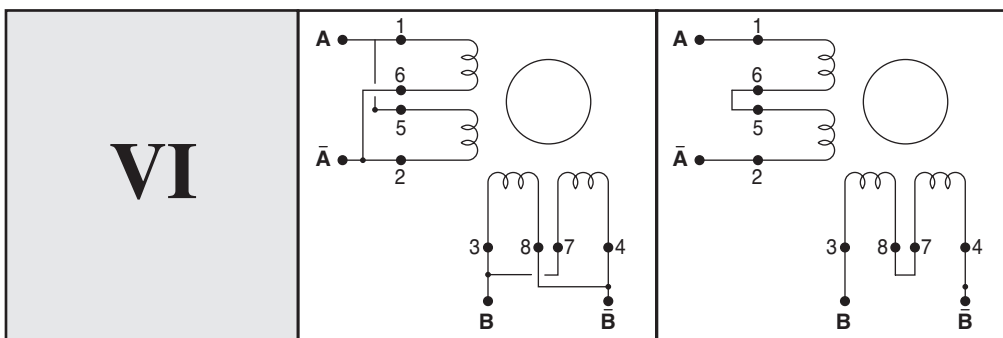
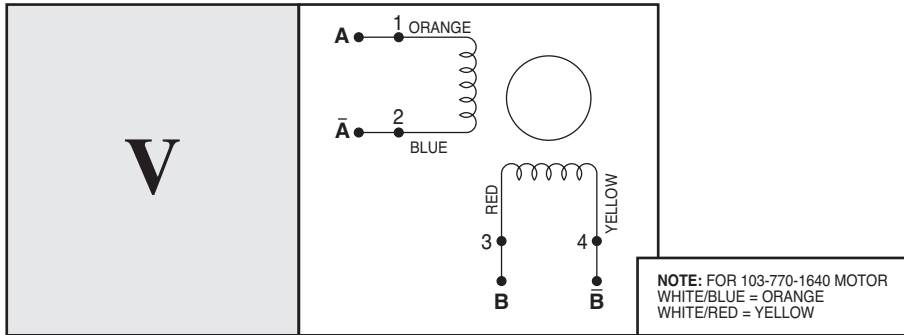

Stepping Motors catalogue

SANYO DENKI
Step-Syn



R.T.A. s.r.l. - Via Enrico Mattei
Frazione Divisa - 27020 MARCIGNAGO (PV) Italy
Tel. +39.0382.929.855 - Fax +39.0382.929.150
www.rta.it - e-mail: info@rta.it



R.T.A. Deutschland GmbH - Bublitzer Straße 34
40599 DÜSSELDORF (Germany)
Tel. +49.211.749.668.60 - Fax +49.211.749.668.66
www.rta-deutschland.de
e-mail: info@rta-deutschland.de

