

# 1.2A Step-Down Switching Regulator with Output Current Limit

## FEATURES

- **Wide Input Range:**  
 Operation from 7.5V to 36V  
 Overvoltage Lockout Protects Circuit through 60V Transients
- **Programmable Output Current Limit (0.4A to 1.2A)**
- **3.3V and 5V Fixed Output Voltage Options**
- **Integrated Boost Diode**
- Fixed Frequency, Peak Current Mode Control  
 LT3663  $f_{SW} = 1.5\text{MHz}$   
 LT3663-X  $f_{SW} = 1\text{MHz}$
- Low Switch  $V_{CESAT}$ : 275mV at 1A
- Internally Compensated
- Thermal Protection
- Thermally Enhanced 8-Pin 2mm × 3mm DFN and MSOP Packages

## APPLICATIONS

- Distributed Supply Regulation
- Automotive Battery Regulation
- Industrial Supplies
- Wall Transformer Regulation

## DESCRIPTION

The LT<sup>®</sup>3663 is a current mode step-down switching regulator with programmable output current limit. The current limit accurately controls the system power dissipation and reduces the size of the power path components.

The wide operating input voltage range of 7.5V to 36V (60V transient) suits the LT3663 to a variety of input sources, including unregulated 12V wall adapters, 24V industrial supplies, and automotive power.

The LT3663 includes a low current shutdown mode, input overvoltage and undervoltage lockout, and thermal shutdown. Internal compensation and boost diode minimize the number of external components. 3.3V and 5V fixed output voltage versions are available.

The LT3663 is available in 8-lead DFN and MSOP packages with exposed pads for low thermal resistance.

LT, LT, LTC, LTM, Linear Technology and the Linear logo are registered trademarks of Linear Technology Corporation. All other trademarks are the property of their respective owners.

## TYPICAL APPLICATION

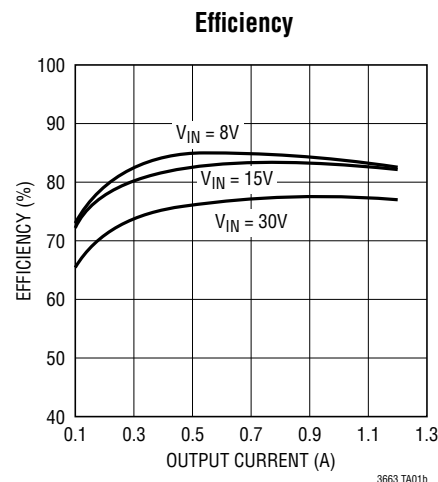
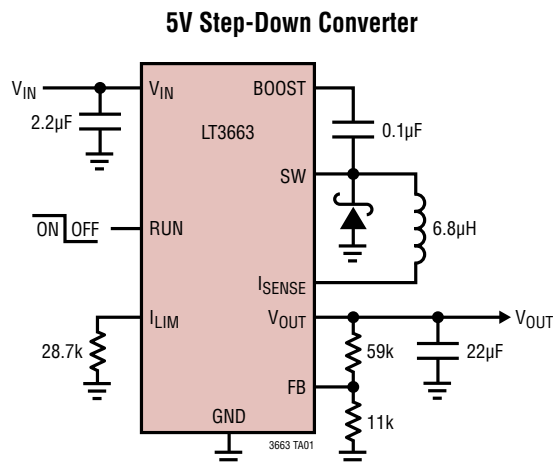

# LT3663

## ABSOLUTE MAXIMUM RATINGS

(Note 1)

Input Voltage ( $V_{IN}$ ) (Note 2).....	60V
BOOST Pin Voltage .....	50V
BOOST Pin Above SW Pin.....	25V
$V_{OUTS}$ , $V_{OUT}$ , $I_{SENSE}$ , FB Pins.....	6V
RUN Pin (Note 2) .....	60V

Operating Junction Temperature Range (Note 3)

LT3663E.....	-40°C to 125°C
LT3663I.....	-40°C to 125°C
LT3663H .....	-40°C to 150°C
Storage Temperature.....	-65°C to 150°C

## PIN CONFIGURATION

<p>LT3663</p> <p>TOP VIEW</p> <p>DCB PACKAGE 8-LEAD (2mm × 3mm) PLASTIC DFN <math>\theta_{JA} = 64^{\circ}\text{C/W}</math> EXPOSED PAD (PIN 9) IS GND, MUST BE SOLDERED TO PCB</p>	<p>LT3663-X</p> <p>TOP VIEW</p> <p>DCB PACKAGE 8-LEAD (2mm × 3mm) PLASTIC DFN <math>\theta_{JA} = 64^{\circ}\text{C/W}</math> EXPOSED PAD (PIN 9) IS GND, MUST BE SOLDERED TO PCB</p>
<p>LT3663</p> <p>TOP VIEW</p> <p>MSE PACKAGE 8-LEAD PLASTIC MSOP <math>\theta_{JA} = 35^{\circ}\text{C/W}</math> EXPOSED PAD (PIN 9) IS GND, MUST BE SOLDERED TO PCB</p>	<p>LT3663-X</p> <p>TOP VIEW</p> <p>MSE PACKAGE 8-LEAD PLASTIC MSOP <math>\theta_{JA} = 35^{\circ}\text{C/W}</math> EXPOSED PAD (PIN 9) IS GND, MUST BE SOLDERED TO PCB</p>

## ORDER INFORMATION

LEAD FREE FINISH	TAPE AND REEL	PART MARKING*	PACKAGE DESCRIPTION	TEMPERATURE RANGE
LT3663EDCB#PBF	LT3663EDCB#TRPBF	LDVK	8-Lead (2mm × 3mm) Plastic DFN	-40°C to 125°C
LT3663IDCB#PBF	LT3663IDCB#TRPBF	LDVK	8-Lead (2mm × 3mm) Plastic DFN	-40°C to 125°C
LT3663EDCB-3.3#PBF	LT3663EDCB-3.3#TRPBF	LFMW	8-Lead (2mm × 3mm) Plastic DFN	-40°C to 125°C
LT3663IDCB-3.3#PBF	LT3663IDCB-3.3#TRPBF	LFMW	8-Lead (2mm × 3mm) Plastic DFN	-40°C to 125°C
LT3663EDCB-5#PBF	LT3663EDCB-5#TRPBF	LFMY	8-Lead (2mm × 3mm) Plastic DFN	-40°C to 125°C
LT3663IDCB-5#PBF	LT3663IDCB-5#TRPBF	LFMY	8-Lead (2mm × 3mm) Plastic DFN	-40°C to 125°C
LT3663EMS8E#PBF	LT3663EMS8E#TRPBF	LTDWT	8-Lead Plastic MSOP	-40°C to 125°C
LT3663IMS8E#PBF	LT3663IMS8E#TRPBF	LTDWT	8-Lead Plastic MSOP	-40°C to 125°C
LT3663HMS8E#PBF	LT3663HMS8E#TRPBF	LTDWT	8-Lead Plastic MSOP	-40°C to 150°C
LT3663EMS8E-3.3#PBF	LT3663EMS8E-3.3#TRPBF	LTFMX	8-Lead Plastic MSOP	-40°C to 125°C
LT3663IMS8E-3.3#PBF	LT3663IMS8E-3.3#TRPBF	LTFMX	8-Lead Plastic MSOP	-40°C to 125°C
LT3663HMS8E-3.3#PBF	LT3663HMS8E-3.3#TRPBF	LTFMX	8-Lead Plastic MSOP	-40°C to 150°C
LT3663EMS8E-5#PBF	LT3663EMS8E-5#TRPBF	LTFMZ	8-Lead Plastic MSOP	-40°C to 125°C

3663fc

## ORDER INFORMATION

LEAD FREE FINISH	TAPE AND REEL	PART MARKING*	PACKAGE DESCRIPTION	TEMPERATURE RANGE
LT3663IMS8E-5#PBF	LT3663IMS8E-5#TRPBF	LTFMZ	8-Lead Plastic MSOP	-40°C to 125°C
LT3663HMS8E-5#PBF	LT3663HMS8E-5#TRPBF	LTFMZ	8-Lead Plastic MSOP	-40°C to 150°C

Consult LTC Marketing for parts specified with wider operating temperature ranges. \*The temperature grade is identified by a label on the shipping container. Consult LTC Marketing for information on non-standard lead based finish parts.

For more information on lead free part marking, go to: <http://www.linear.com/leadfree/>

For more information on tape and reel specifications, go to: <http://www.linear.com/tapeandreel/>

## ELECTRICAL CHARACTERISTICS

The ● denotes the specifications which apply over the full operating temperature range, otherwise specifications are at  $T_A = 25^\circ\text{C}$ .  $V_{IN} = 12\text{V}$ ,  $R_{ILIM} = 36.5\text{k}$  unless otherwise noted.

PARAMETER	CONDITIONS	MIN	TYP	MAX	UNITS
$V_{IN}$ Undervoltage Lockout	Rising ●		7	7.5	V
$V_{IN}$ Undervoltage Lockout Hysteresis			500		mV
$V_{IN}$ Overvoltage Lockout	Rising ●	36	39	41	V
$V_{IN}$ Overvoltage Lockout Hysteresis			1		V
$V_{IN}$ Supply Current	Not Switching		2.4	3.2	mA
$V_{IN}$ Supply Current in Shutdown	$V_{RUN} = 0\text{V}$		0.01	2	$\mu\text{A}$
Run Input Voltage High		2.5			V
Run Input Voltage Low				0.3	V
Run Pin Bias Current	$V_{RUN} = 2.3\text{V}$ (Note4) $V_{RUN} = 0\text{V}$		6 0.01	15 0.1	$\mu\text{A}$ $\mu\text{A}$
$V_{OUT}$ Current Limit Range	●	0.4		1.2	A
$V_{OUT}$ Current Limit	●	0.8	1	1.2	A
Operating Frequency	LT3663 LT3663-X	1350 900	1500 1000	1650 1100	kHz kHz
Maximum Duty Cycle	●	80	92		%
Feedback Voltage	LT3663 ●	784	800	816	mV
FB Bias Current	$V_{FB} = 0.8\text{V}$ , LT3663		50	150	nA
Regulated Output Voltage	LT3663-3.3 ● LT3663-5 ●	3.234 4.900	3.3 5	3.366 5.100	V V
$V_{OUTS}$ Bias Current	LT3663-X		90	120	$\mu\text{A}$
Switch Peak Current Limit	(Note 5) ●	1.6	2	2.5	A
Switch $V_{CESAT}$	$I_{SW} = 1\text{A}$		275		mV
Minimum BOOST Voltage	$I_{SW} = 1\text{A}$ (Note 6)		1.85	2.2	V
Boost Diode Drop	$I_{DIODE} = 60\text{mA}$		0.9	1.2	V
Boost Pin Current	$I_{SW} = 1\text{A}$		28		mA

**Note 1:** Stresses beyond those listed under Absolute Maximum Ratings may cause permanent damage to the device. Exposure to any Absolute Maximum Rating condition for extended periods may affect device reliability and lifetime.

**Note 2:** Absolute Maximum Voltage at  $V_{IN}$  and RUN pins is 60V for nonrepetitive 1 second transients.

**Note 3:** The LT3663E is guaranteed to meet performance specifications from 0°C to 125°C. Specifications over the -40°C to 125°C operating temperature range are assured by design, characterization, and correlation with statistical process controls. The LT3663I specifications

are guaranteed over the full -40°C to 125°C temperature range. The LT3663H specifications are guaranteed over the -40°C to 150°C operating temperature range. High junction temperatures degrade operating lifetimes. Operating lifetime is derated at junction temperatures greater than 125°C.

**Note 4:** Current flows into pin.

**Note 5:** Switch Peak Current Limit guaranteed by design and/or correlation to static test.

**Note 6:** This is the minimum voltage across the boost capacitor needed to guarantee full saturation of the switch.

## TYPICAL PERFORMANCE CHARACTERISTICS $T_A = 25^\circ\text{C}$ , unless otherwise noted.

### $V_{IN}$ Undervoltage Lockout

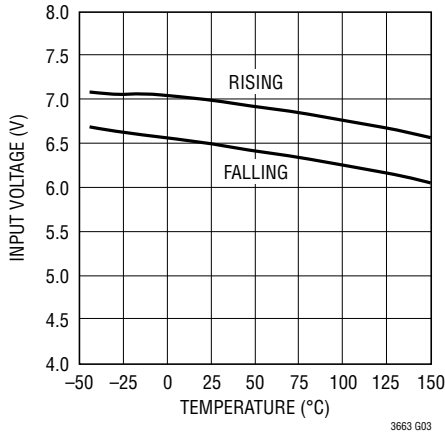

### $V_{IN}$ Overvoltage Lockout

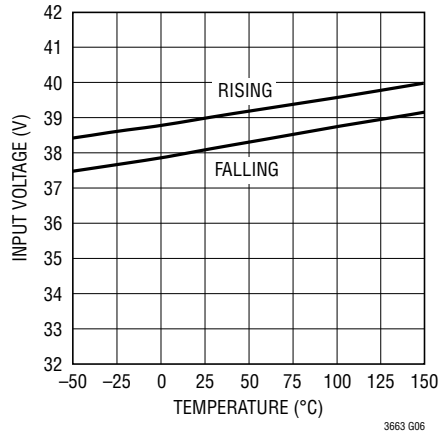

### $V_{IN}$ Shutdown Current

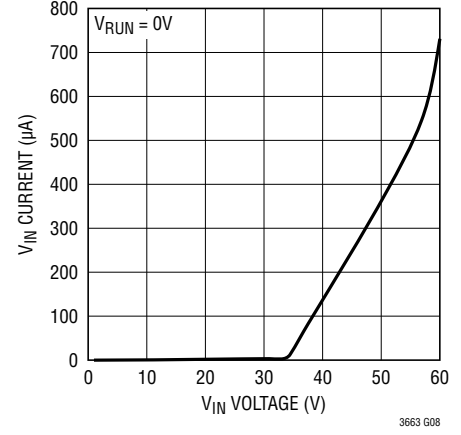

### RUN Pin Current

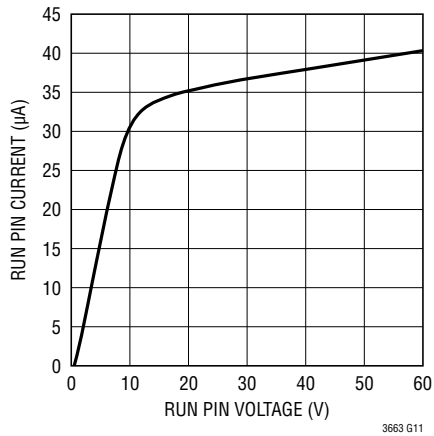

### Output Current Limit

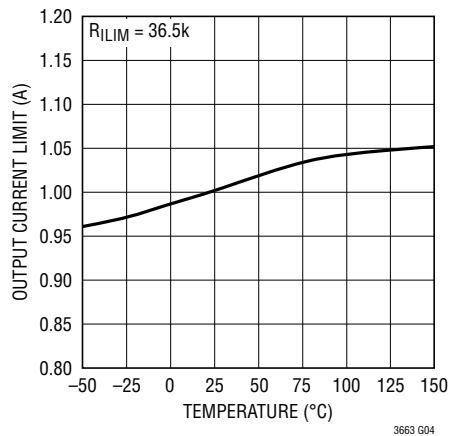

### Output Current Limit

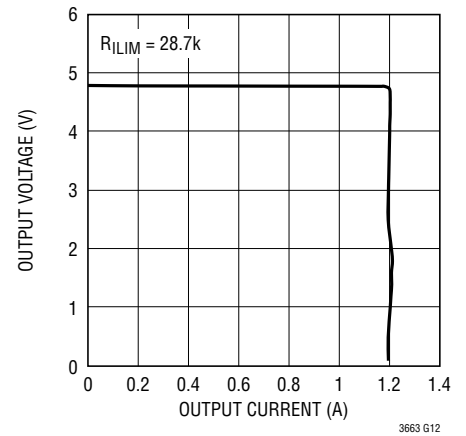

### Switching Frequency

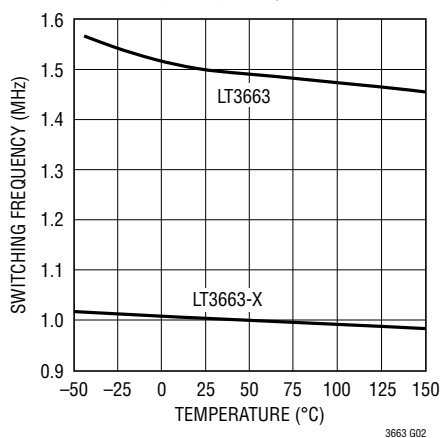

### Minimum Switch On-Time

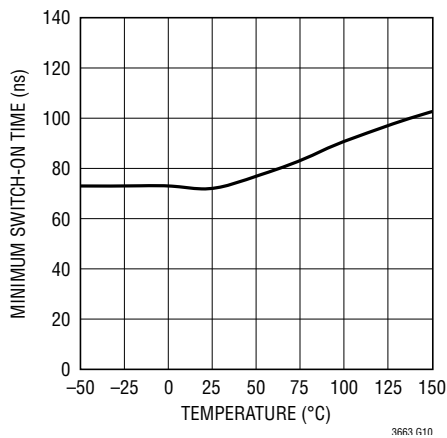

### Feedback Voltage

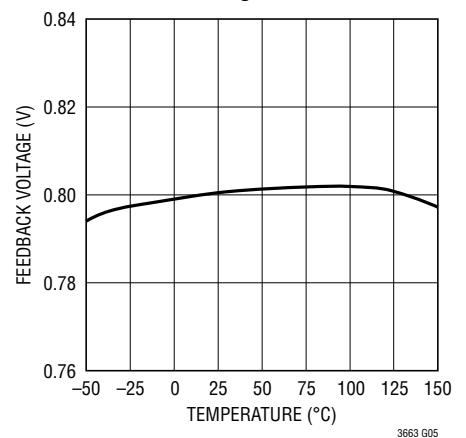

**TYPICAL PERFORMANCE CHARACTERISTICS**  $T_A = 25^\circ\text{C}$ , unless otherwise noted.

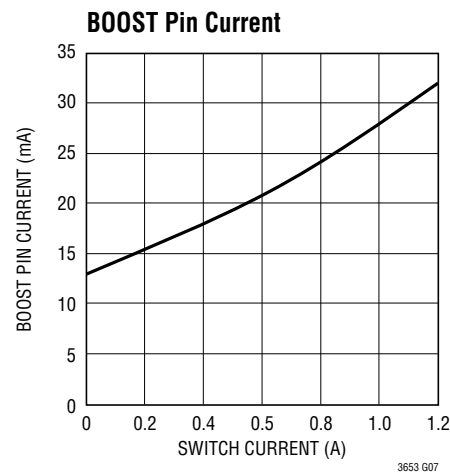
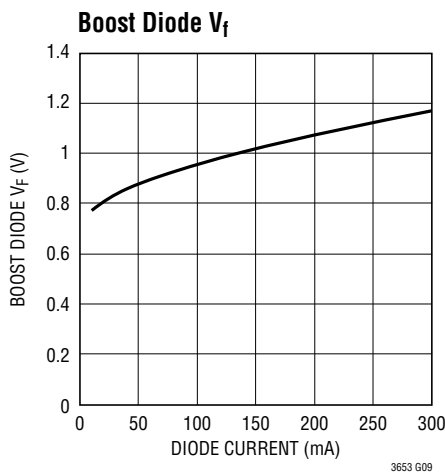
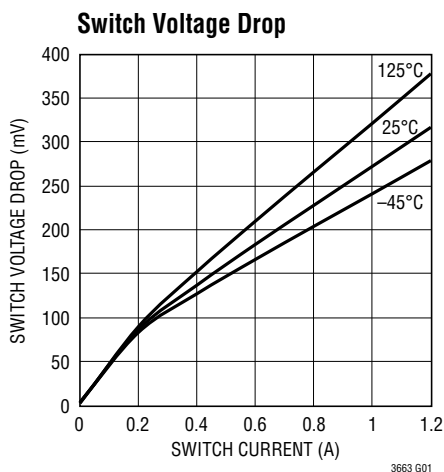

**PIN FUNCTIONS**

**BOOST:** The BOOST pin is used to provide a drive voltage, higher than the input voltage, to the internal power switch. The BOOST pin is also internally connected to the cathode of the BOOST diode.

**GND (Exposed Pad Pin 9) :** Ground. The exposed pad must be soldered to the PCB and electrically connected to ground. Use a large ground plane and thermal vias to optimize thermal performance.

**FB (LT3663):** The LT3663 regulates the FB pin to 0.8V. Connect the feedback resistor divider tap to this pin.

**I<sub>LIM</sub>:** Output Current Limit Program Pin. Connect a resistor to ground to program the regulator output current limit.

**I<sub>SENSE</sub>:** The I<sub>SENSE</sub> pin is the positive input to the internal output current limit sense resistor. The I<sub>SENSE</sub> pin is also the anode to the internal BOOST diode.

**RUN:** The Run pin is used to put the LT3663 into shutdown mode. Tie to ground to shut down the LT3663. Tie to 2.5V or more for normal operation. If the shutdown feature is not used, connect this pin to V<sub>IN</sub>.

**SW:** The SW pin is the output of the internal power switch. Connect this pin to the inductor, catch diode and boost capacitor.

**V<sub>IN</sub>:** The V<sub>IN</sub> pin supplies current to the LT3663's internal regulator and internal power switch. Capacitively bypass the pin to ground.

**V<sub>OUT</sub>:** The V<sub>OUT</sub> pin is connected to the negative terminal of the internal output current limit sense resistor.

**V<sub>OUTS</sub> (LT3663-X):** Output Voltage Sense Pin. Connect to the positive terminal of the output capacitor.

**FUNCTIONAL BLOCK DIAGRAM**

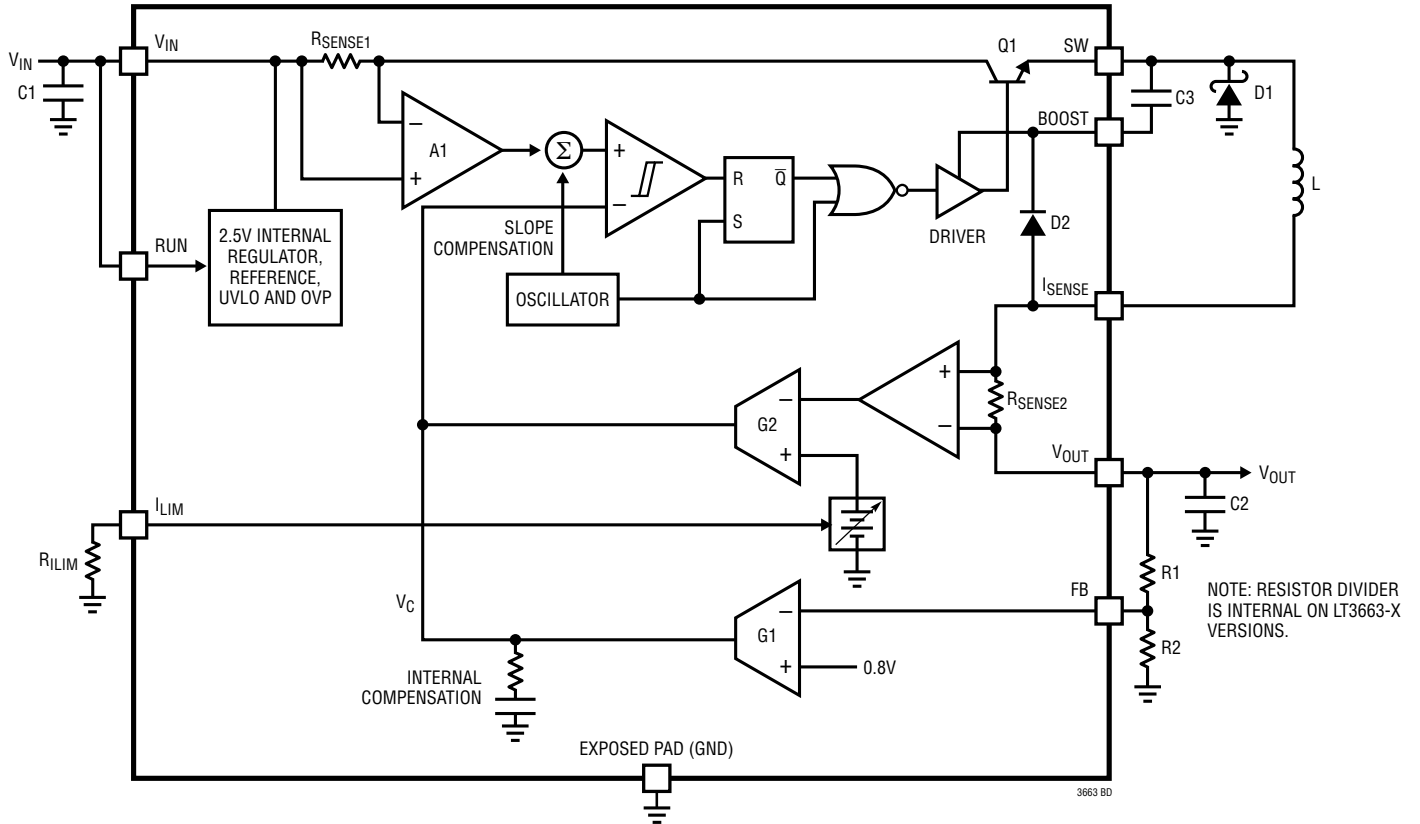

## OPERATION (Refer to Block Diagram)

The LT3663 is a constant frequency, current mode step down regulator. A switch cycle is initiated when the oscillator enables the RS flip flop, turning on the internal power switch, Q1. The sense amplifier (A1) monitors the switch current via the voltage dropped across the current sense resistor  $R_{SENSE1}$ . The comparator compares the amplified current signal with the output ( $V_C$ ) of the error amplifier (G1). The switch is turned off when this current exceeds a value determined by the  $V_C$  voltage. The error amplifier monitors the  $V_{OUT}$  voltage through an internal resistor divider and, when not driven externally, servos the  $V_C$  voltage to regulate  $V_{OUT}$ . If the  $V_{OUT}$  voltage drops, the  $V_C$  voltage will be driven higher increasing the output current and  $V_{OUT}$  voltage. An active clamp (not shown) on the  $V_C$  node provides current limit. The LT3663 is internally compensated with a pole-zero combination on the  $V_C$  node.

An external capacitor and internal diode, D2, generate a voltage at the BOOST pin that is higher than the input supply.

This allows the driver to fully saturate the internal bipolar NPN power switch for efficient operation. The switch driver operates from either  $V_{IN}$  or BOOST to ensure startup.

An internal regulator provides power to the control circuitry. This regulator includes input undervoltage and overvoltage protection which disables switching action when  $V_{IN}$  is out of range. When switching is disabled, the LT3663 safely sustains input voltages up to 60V. Note that while switching is disabled the output will discharge.

Output current limiting is provided via the servo action of amplifier G2. The voltage across sense resistor,  $R_{SENSE2}$ , is compared to a voltage programmed by external resistor  $R_{ILIM}$  on the  $I_{LIM}$  pin. A capacitor averages the inductor ripple current. If the average inductor current exceeds the programmed value then the  $V_C$  voltage is pulled low, reducing the current in the regulator. The output current limit circuit allows for a lower current rated inductor and diode and provides better control of system power dissipation.

## APPLICATIONS INFORMATION

### FB Resistor Network

The output voltage of the LT3663 is programmed with a resistor divider. Choose the 1% resistors according to:

$$R1 = R2 (V_{OUT}/0.8 - 1)$$

Reference designators refer to the Block Diagram.

The resistor divider is internal on the fixed output voltage versions, LT3663-X.

### Minimum Duty Cycle

As the input voltage increases the duty cycle decreases. At some point, the minimum duty cycle of the IC is reached and pulse skipping begins. The output voltage continues to regulate but the output voltage ripple increases. The input voltage at which this occurs is calculated as follows:

$$V_{IN} = \frac{(V_{OUT} + V_F)}{DC_{MIN}} - V_F + V_{SW}$$

Where  $V_F$  is the forward voltage drop of the catch diode, D1, and  $V_{SW}$  is the voltage drop on the internal switch, Q1. LT3663  $DC_{MIN}$  is typically 0.12.

For  $V_F = 0.4V$ ,  $V_{SW} = 0.3V$ , and  $V_{OUT} = 3.3V$  pulse skipping occurs at about 24.5V.

Figure 1 illustrates switching waveforms in normal mode for a 3.3V output application with  $V_{IN} = 20V$ .

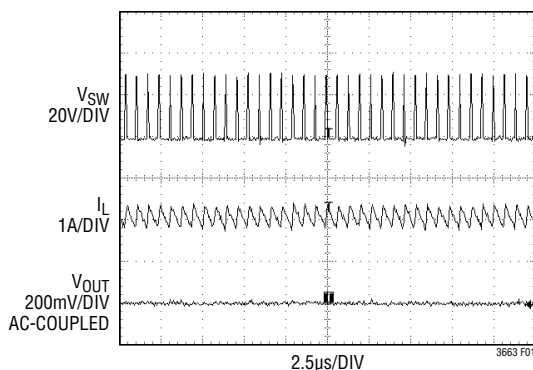

Figure 1. Normal Operation

Figure 2. illustrates switching waveforms in pulse skip mode a 3.3V output application with  $V_{IN} = 30V$ .

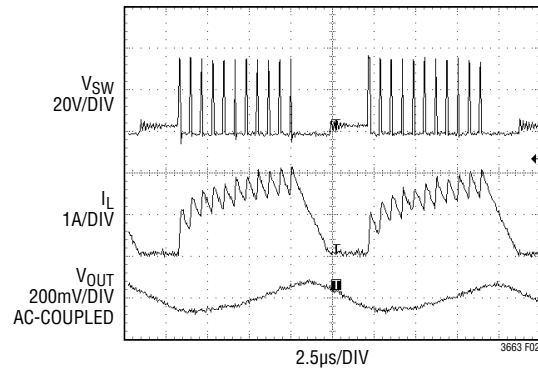

Figure 2. Pulse-Skip Mode

### Inductor Selection

A good first choice for the inductor value is:

$$L = V_{OUT} + V_D (\mu H)$$

where  $V_D$  is the voltage drop of the catch diode (~0.4V) and  $L$  is in  $\mu H$ . With this value there is no sub-harmonic oscillation for applications with 50% or greater duty cycle. The inductor's RMS current rating must be greater than the maximum load current. Size the inductor so the saturation current rating is about 30% higher than the maximum load current. The output current limit circuit tightly controls the maximum average inductor current, therefore the inductor RMS current rating does not have to be overrated to handle short circuit or overload conditions. For high efficiency, keep the series resistance (DCR) less than  $0.1\Omega$ . A higher value inductor is larger in size and slows transient response but reduces output voltage ripple. A lower value inductor has higher ripple currents but is physically smaller or, for the same size, it has lower DCR typically resulting in higher efficiency.



## APPLICATIONS INFORMATION

### Catch Diode

The catch diode conducts current only during switch-off time. Average forward current in normal operation is calculated from:

$$I_{D(AVG)} = I_{OUT} \frac{V_{IN} - V_{OUT}}{V_{IN}}$$

where  $I_{OUT}$  is the maximum output load current programmed by the  $I_{LIM}$  resistor. Peak reverse voltage is equal to the regulator input voltage. Use a Schottky diode with a reverse voltage rating greater than the input voltage. The overvoltage protection feature in the LT3663 keeps the switch off when  $V_{IN} > 39V$  (typical) allowing the use of a 45V rated Schottky even when  $V_{IN}$  ranges up to 60V.

### Input Capacitor

Bypass the input of the LT3663 circuit with a 1μF or higher value ceramic capacitor of X7R or X5R type. Y5V types have poor performance over temperature and applied voltage and are not recommended. If the input power source has high impedance, or there is significant inductance due to long wires or cables, additional bulk capacitance may be necessary. This can be provided with a low performance electrolytic capacitor. Step-down regulators draw current from the input supply in pulses with very fast rise and fall times. The input capacitor is required to reduce the resulting voltage ripple at the LT3663 and to force this very high frequency switching current into a tight local loop, minimizing EMI. Place the capacitor in close proximity to the LT3663 and the catch diode; (see the PCB Layout section).

### Output Capacitor

A 10μF or greater ceramic capacitor is recommended to provide low output ripple and good transient response. Ceramic capacitors have very low equivalent series resistance (ESR) and provide the best ripple performance.

Use X5R or X7R types and keep in mind that a ceramic capacitor biased with  $V_{OUT}$  has less than its specified nominal capacitance.

High performance electrolytic capacitors can be used for the output capacitor. Low ESR is important, so choose one that is intended for use in switching regulators. Keep the ESR less than 0.1Ω.

### $I_{LIM}$ Resistor

The LT3663 output current limit controls the maximum current delivered from the LT3663 regulator. This allows tighter control of the system power dissipation and also protects the inductor and diode from overheating during an overload or short circuit condition. A resistor connected from  $I_{LIM}$  pin to GND programs the output current. Table 1 details the  $I_{LIM}$  resistor values for specific output current limits.

**Table 1. Output Current Limit vs  $R_{LIM}$  Value**

OUTPUT CURRENT LIMIT (A)	$R_{LIM}$ VALUE (kΩ)
0.4	140
0.6	75
0.8	48.7
1.0	36.5
1.2	28.7

There may be a reason in some applications to move the output current limit. The following simple circuit demonstrates how the output current limit can be adjusted:

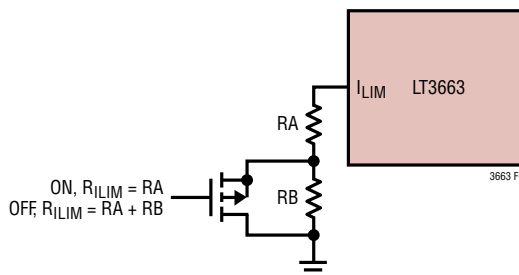

**Figure 3. Circuit for Multiple Values of Output Current Limit**

## APPLICATIONS INFORMATION

### BOOST and BIAS Pin Considerations

Capacitor C3 and the internal boost diode (see the Block Diagram) are used to generate a boost voltage that is higher than the input voltage. In most cases a  $0.1\mu\text{F}$  capacitor works well. Figure 4 shows three ways to arrange the boost circuit. The BOOST pin must be more than 2.3V above the SW pin for best efficiency. For outputs of 3V and above, the standard circuit (Figure 4a) is best. For outputs between 2.8V and 3V, use a  $1\mu\text{F}$  boost capacitor. A 2.5V output presents a special case because it is marginally adequate to support the boosted drive stage while using the internal

boost diode. For reliable BOOST pin operation with 2.5V outputs use a good external Schottky diode (such as the ON Semi, MBR0540) and a  $1\mu\text{F}$  boost capacitor (see Figure 4b). For lower output voltages connect an external Schottky diode to the input (Figure 4c), or to another supply greater than 2.8V. Using  $V_{\text{IN}}$  reduces the maximum input voltage to 25V. The circuit in Figure 4a is more efficient because the BOOST pin current comes from a lower voltage source. Take care to ensure that the maximum voltage ratings of the BOOST pin is not exceeded.

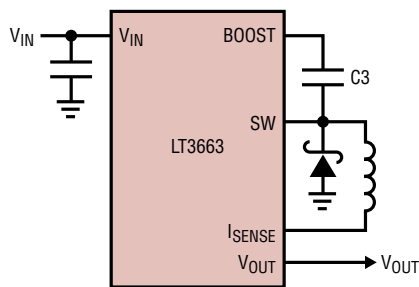

(4a) For  $V_{\text{OUT}} > 2.8\text{V}$

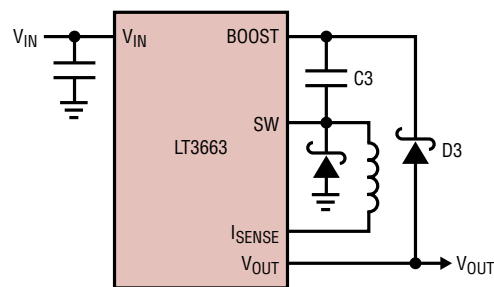

(4b) For  $2.5\text{V} < V_{\text{OUT}} < 2.8\text{V}$

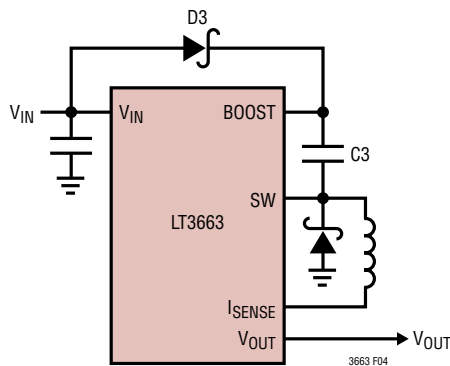

(4c) For  $V_{\text{OUT}} < 2.5\text{V}$ ;  $V_{\text{IN}(\text{MAX})} = 25\text{V}$

Figure 4. Three Circuits to Generate BOOST Pin Voltage

## APPLICATIONS INFORMATION

### PCB Layout

Proper operation and minimum EMI, requires careful printed circuit board layout. Figure 5 shows the recommended component placement with trace, ground plane and via locations. Note that large, switched currents flow in the LT3663's  $V_{IN}$  and SW pins, the catch diode (D2) and the input capacitor (C1). Keep the loop formed by these components as small as possible and tied to system ground in only one place. Locate these components, along with the inductor and output capacitor, on the same side of the circuit board, and keep their connections on that layer. Place a local, unbroken ground plane below these components, and tie this ground plane to system ground at one location, ideally at the ground terminal of the output capacitor C1. Make the SW and BOOST PCB trace as short as possible. Include vias near the exposed GND pad of the LT3663 to help remove heat from the LT3663 to the ground plane.

### High Temperature Considerations

The die temperature of the LT3663 must not exceed the maximum rating. This is generally not a concern unless

the ambient temperature is above 85°C. For higher temperatures, take care in the layout of the circuit to ensure good heat sinking of the LT3663. De-rate the maximum load current as the ambient temperature approaches the maximum temperature rating. Calculate the die temperature by multiplying the LT3663 power dissipation by the thermal resistance from junction to ambient. Estimate the power dissipation within the LT3663 by calculating the total power loss from an efficiency measurement and subtracting the catch diode loss. Thermal resistance depends on the layout of the circuit board, but 64°C/W is typical for the (2mm × 3mm) DFN (DCB) package.

### Other Linear Technology Publications

Application Notes 19, 35 and 44 contain more detailed descriptions and design information for Buck regulators and other switching regulators. The LT1376 data sheet has a more extensive discussion of output ripple, loop compensation and stability testing. Design Note 100 shows how to generate a bipolar output supply using a Buck regulator.

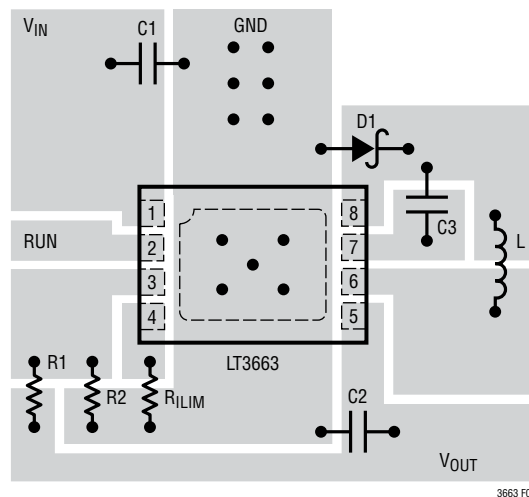
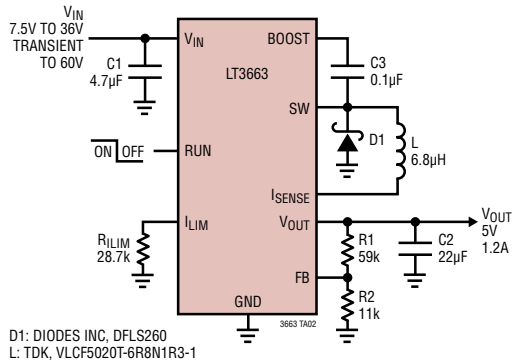

Figure 5. LT3663 PCB Layout

## TYPICAL APPLICATIONS

### 5V Step-Down Converter



### 2.5V Step-Down Converter

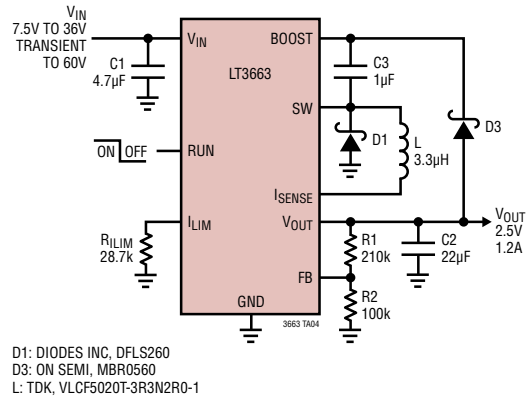

### 1.2V Step-Down Converter

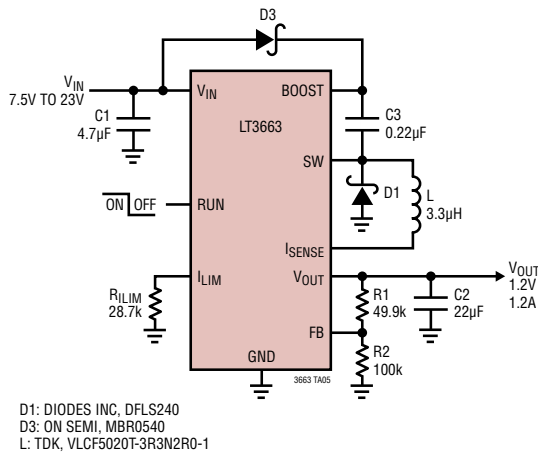

### LT3663-5 5V Step-Down Regulator with Isolated 3.3V Output

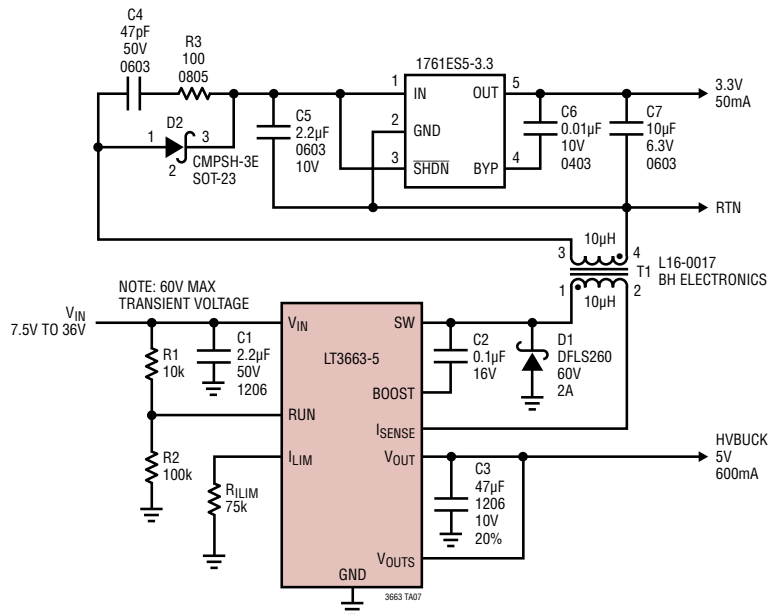

# PACKAGE DESCRIPTION

**DCB Package**  
**8-Lead Plastic DFN (2mm × 3mm)**  
 (Reference LTC DWG # 05-08-1718 Rev A)

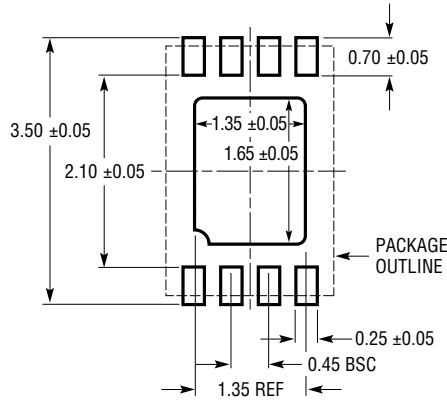

RECOMMENDED SOLDER PAD PITCH AND DIMENSIONS  
 APPLY SOLDER MASK TO AREAS THAT ARE NOT SOLDERED

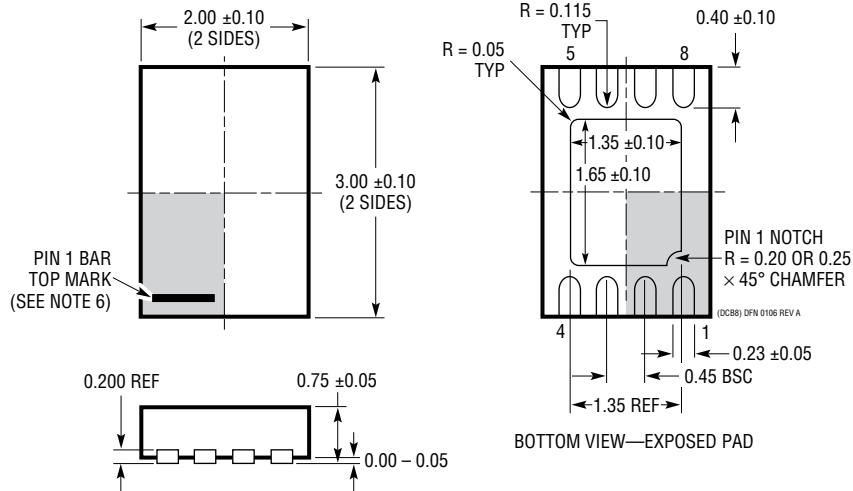

- NOTE:
1. DRAWING IS NOT A JEDEC PACKAGE OUTLINE
  2. DRAWING NOT TO SCALE
  3. ALL DIMENSIONS ARE IN MILLIMETERS
  4. DIMENSIONS OF EXPOSED PAD ON BOTTOM OF PACKAGE DO NOT INCLUDE MOLD FLASH. MOLD FLASH, IF PRESENT, SHALL NOT EXCEED 0.15mm ON ANY SIDE
  5. EXPOSED PAD SHALL BE SOLDER PLATED
  6. SHADED AREA IS ONLY A REFERENCE FOR PIN 1 LOCATION ON THE TOP AND BOTTOM OF PACKAGE

**MS8E Package**  
**8-Lead Plastic MSOP, Exposed Die Pad**  
 (Reference LTC DWG # 05-08-1662 Rev J)

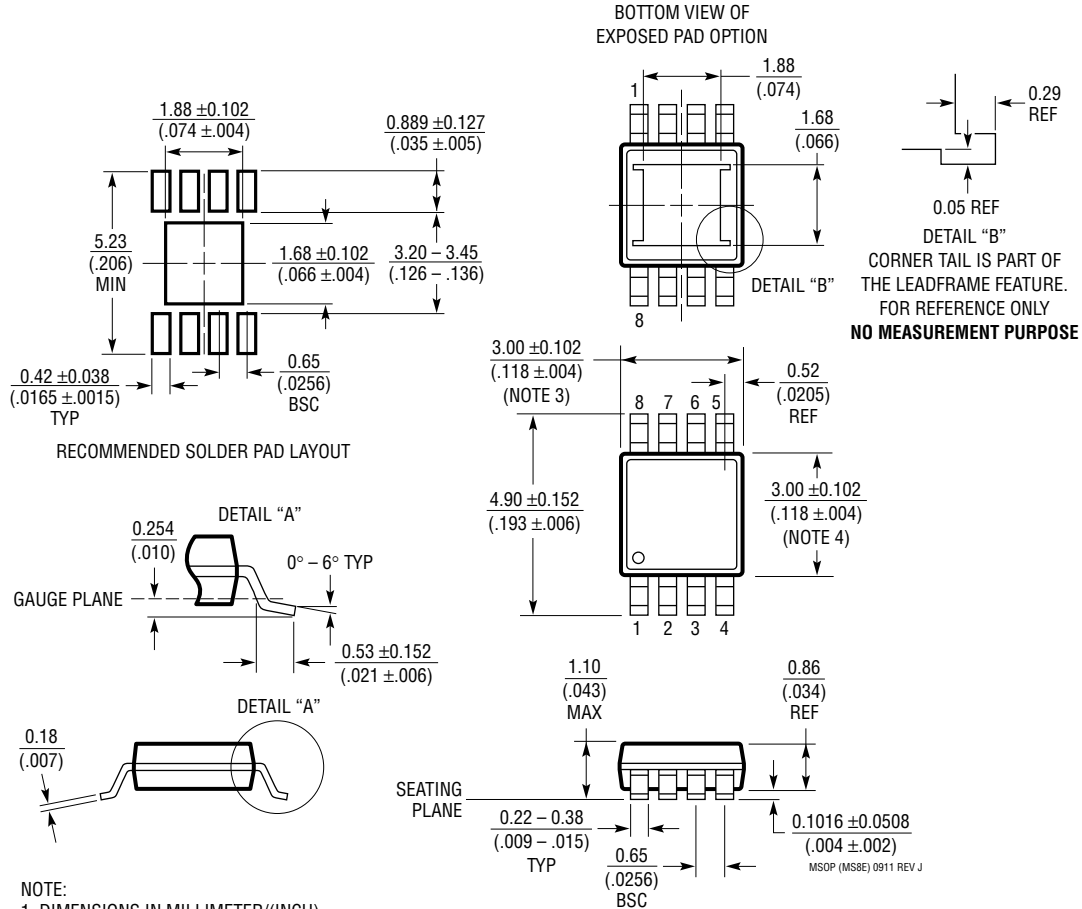

- NOTE:
1. DIMENSIONS IN MILLIMETER/(INCH)
  2. DRAWING NOT TO SCALE
  3. DIMENSION DOES NOT INCLUDE MOLD FLASH, PROTRUSIONS OR GATE BURRS. MOLD FLASH, PROTRUSIONS OR GATE BURRS SHALL NOT EXCEED 0.152mm (.006") PER SIDE
  4. DIMENSION DOES NOT INCLUDE INTERLEAD FLASH OR PROTRUSIONS. INTERLEAD FLASH OR PROTRUSIONS SHALL NOT EXCEED 0.152mm (.006") PER SIDE
  5. LEAD COPLANARITY (BOTTOM OF LEADS AFTER FORMING) SHALL BE 0.102mm (.004") MAX
  6. EXPOSED PAD DIMENSION DOES INCLUDE MOLD FLASH. MOLD FLASH ON E-PAD SHALL NOT EXCEED 0.254mm (.010") PER SIDE.

**REVISION HISTORY** (Revision history begins at Rev B)

REV	DATE	DESCRIPTION	PAGE NUMBER
B	11/09	Additions to Features	1
		Text Changes to Description	1
		Addition of MSE Package to Pin Configuration	2
		Additions Made to Order Information	2, 3
		Changes to Electrical Characteristics	3
		Expanded Temperature Range of Typical Performance Curves	4, 5
		Addition of Note to Functional Block Diagram	6
		Text Changes to Applications Information	8, 11
		Addition of Typical Applications Drawing	12
		Addition of MS8E Package Drawing	14
C	05/13	Clarified PCB Layout	11

## TYPICAL APPLICATION

### 3.3V Step-Down Converter

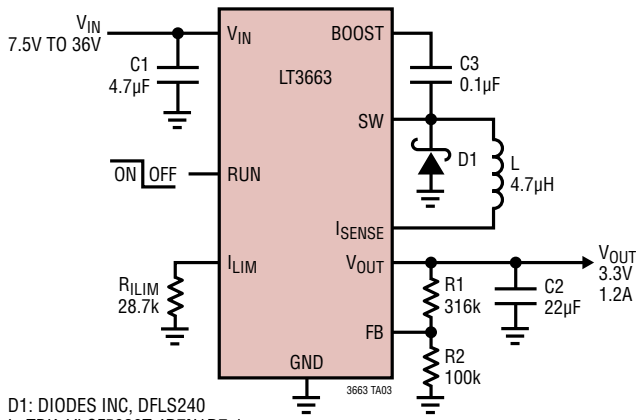

### Efficiency

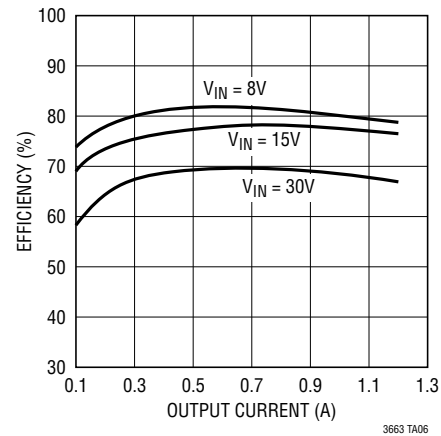

## RELATED PARTS

PART NUMBER	DESCRIPTION	COMMENTS
LT1766	60V, 1.2A (I <sub>OUT</sub> ), 200kHz, High Efficiency Step-Down DC/DC Converter	V <sub>IN</sub> : 5.5V to 60V, V <sub>OUTMAX</sub> = 1.20V, I <sub>Q</sub> = 2.5mA, I <sub>SD</sub> = 25µA, TSSOP16/TSSOP16E Packages
LT1933	500mA(I <sub>OUT</sub> ), 500kHz Step-Down Switching Regulator in SOT-23	V <sub>IN</sub> : 3.6V to 36V, V <sub>OUTMAX</sub> = 1.2V, I <sub>Q</sub> = 1.6mA, I <sub>SD</sub> <1µA, ThinSOT Package
LT1936	36V, 1.4A(I <sub>OUT</sub> ), 500kHz High Efficiency Step-Down DC/DC Converter	V <sub>IN</sub> : 3.6V to 36V, V <sub>OUTMAX</sub> = 1.2V, I <sub>Q</sub> = 1.9mA, I <sub>SD</sub> <1µA, MS8E Package
LT1940	Dual 25V, 1.4A (I <sub>OUT</sub> ), 1.1MHz, High Efficiency Step-Down DC/DC Converter	V <sub>IN</sub> : 3.6V to 25V, V <sub>OUTMAX</sub> = 1.20V, I <sub>Q</sub> = 3.8mA, I <sub>SD</sub> <30µA, TSSOP16E Package
LT1976/LT1977	60V, 1.2A (I <sub>OUT</sub> ), 200/500kHz, High Efficiency Step-Down DC/DC Converter with BurstMode® Operation	V <sub>IN</sub> : 3.3V to 60V, V <sub>OUTMAX</sub> = 1.20V, I <sub>Q</sub> = 100µA, I <sub>SD</sub> <1µA, TSSOP16E Package
LTC3407/LTC3407-2	Dual 600mA/800mA, 1.5/2.25 MHz Synchronous Step-Down DC/DC Converter	V <sub>IN</sub> : 2.5V to 5.5V, V <sub>OUTMAX</sub> = 0.6V, I <sub>Q</sub> = 40µA, I <sub>SD</sub> <1µA, 3mm × 3mm DFN, MS10E Packages
LT3434/LT3435	60V, 2.4A (I <sub>OUT</sub> ), 200/500kHz, High Efficiency Step-Down DC/DC Converter with BurstMode Operation	V <sub>IN</sub> : 3.3V to 60V, V <sub>OUTMAX</sub> = 1.20V, I <sub>Q</sub> = 100µA, I <sub>SD</sub> <1µA, TSSOP16E Package
LT3437	60V, 400mA (I <sub>OUT</sub> ), MicroPower Step-Down DC/DC Converter with BurstMode Operation	V <sub>IN</sub> : 3.3V to 60V, V <sub>OUTMAX</sub> = 1.25V, I <sub>Q</sub> = 100µA, I <sub>SD</sub> <1µA, 3mm × 3mm DFN, TSSOP16E Packages
LT3493	36V, 1.4A(I <sub>OUT</sub> ), 750kHz High Efficiency Step-Down DC/DC Converter	V <sub>IN</sub> : 3.6V to 36V, V <sub>OUTMAX</sub> = 0.8V, I <sub>Q</sub> = 1.9mA, I <sub>SD</sub> <1µA, 2mm × 3mm DFN Package
LT3501	Dual 25V, 3A (I <sub>OUT</sub> ), 1.5MHz, High Efficiency Step-Down DC/DC Converter	V <sub>IN</sub> : 3.3V to 25V, V <sub>OUTMAX</sub> = 0.8V, I <sub>Q</sub> = 3.7mA, I <sub>SD</sub> <10µA, TSSOP-20E Package
LT3503	20V, 1A (I <sub>OUT</sub> ), 2.2MHz, High Efficiency Step-Down DC/DC Converter	V <sub>IN</sub> : 3.6V to 20V, V <sub>OUTMAX</sub> = 0.78V, I <sub>Q</sub> = 1.9mA, I <sub>SD</sub> <1µA, 2mm × 3mm DFN, Package
LT3505	36V, 1.2A (I <sub>OUT</sub> ), 3MHz, High Efficiency Step-Down DC/DC Converter	V <sub>IN</sub> : 3.6V to 36V, V <sub>OUTMAX</sub> = 0.78V, I <sub>Q</sub> = 2mA, I <sub>SD</sub> <2µA, 3mm × 3mm DFN, MS8E Packages
LT3506/LT3506A	Dual 25V, 1.6A (I <sub>OUT</sub> ), 575kHz/1.1MHz, High Efficiency Step-Down DC/DC Converter	V <sub>IN</sub> : 3.6V to 25V, V <sub>OUTMAX</sub> = 0.8V, I <sub>Q</sub> = 3.8mA, I <sub>SD</sub> <30µA, 4mm × 5mm DFN Package
LT3508	Dual 36V, 1.4A (I <sub>OUT</sub> ), 2.5MHz, High Efficiency Step-Down DC/DC Converter	V <sub>IN</sub> : 3.6V to 36V, V <sub>OUTMAX</sub> = 0.8V, I <sub>Q</sub> = 4.3mA, I <sub>SD</sub> <1µA, 4mm × 4mm QFN, TSSOP16E Packages
LT3510	Dual 25V, 2A (I <sub>OUT</sub> ), 1.5MHz, High Efficiency Step-Down DC/DC Converter	V <sub>IN</sub> : 3.3V to 25V, V <sub>OUTMAX</sub> = 0.8V, I <sub>Q</sub> = 3.7mA, I <sub>SD</sub> <10µA, TSSOP-20E Package
LTC3548	Dual 400mA + 800mA, 2.25 MHz Synchronous Step-Down DC/DC Converter	V <sub>IN</sub> : 2.5V to 5.5V, V <sub>OUTMAX</sub> = 0.6V, I <sub>Q</sub> = 40µA, I <sub>SD</sub> <1µA, 3mm × 3mm DFN, MS10E Packages

BurstMode is a registered trademark of Linear Technology Corporation.



## X-ON Electronics

Largest Supplier of Electrical and Electronic Components

*Click to view similar products for [Switching Voltage Regulators](#) category:*

*Click to view products by [Analog Devices](#) manufacturer:*

Other Similar products are found below :

[TLF30682QVS01XUMA1](#) [TPSM84209RKHR](#) [FAN53526UC106X](#) [FAN53526UC128X](#) [MP1587EN-LF](#) [FAN48610BUC33X](#)  
[FAN48617UC50X](#) [FAN53526UC89X](#) [MIC45116-1YMP-T1](#) [NCV891234MW50R2G](#) [EN2342QI](#) [AST1S31PUR](#) [16017](#) [A6986FTR](#)  
[NCP81103MNTXG](#) [NCP81203PMNTXG](#) [MAX17242ETPA+](#) [MAX16935RATEB/V+](#) [MP2313GJ-Z](#) [NCP81208MNTXG](#) [MP8759GD-Z](#)  
[FAN53526UC100X](#) [FAN53526UC84X](#) [PCA9412AUKZ](#) [MP2314SGJ-Z](#) [AS1340A-BTDM-10](#) [MP3421GG-P](#) [NCP81109GMNTXG](#)  
[MP6003DN-LF-Z](#) [MAX16935BAUES/V+](#) [LT8315IFE#PBF](#) [SCY1751FCCT1G](#) [NCP81109JMNTXG](#) [MAX16956AUBA/V+](#)  
[AP3409ADNTR-G1](#) [FAN48623UC36FX](#) [MPQ2454GH](#) [MPQ2454GH-AEC1](#) [MP21148GQD-P](#) [AS3701B-BWLM-68](#) [MPQ2143DJ-P](#)  
[MP9942AGJ-P](#) [MP8759GD-P](#) [MP5610GQG-P](#) [MP28200GG-P](#) [MP2451DJ-LF-Z](#) [MP2326GD-P](#) [MP2314SGJ-P](#) [MP2158AGQH-P](#)  
[MP2148GQD-18-P](#)