

FH63 Series



Single action lock (Dimension diagram : 30pos.)

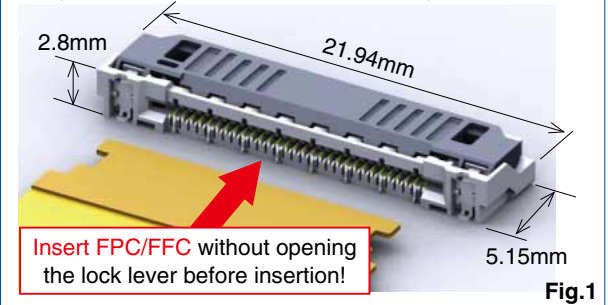

Fig.1

■ Features

1. Automatic single action locking design

- Single action locking by simply inserting FPC after mounting contributes to enhanced workability. (Fig.1) (Lock release by operating the lock lever when removing.)
- Operation of the lock lever is not required at the time of mating FPC. Can be inserted with one hand. Contributes to reduced assembly time. The lock lever will not be damaged by operation. Mating failure is reduced by eliminating the need to operate a lever while mating.

2. Two-points of contact prevents contact failure by dust

- High contact reliability by independent spring two-point contact design, preventing contact failure by dust. (Fig.2)

3. Supports FPC/FFC/Shield FFC

- FH63 allows you to choose from FPC/FFC/Shield FFC.
- Shielded FFC is acceptable for EMI prevention. (Fig.3)

4. High FPC retention force

- The circuit is automatically locked after FPC/FFC is inserted by a single action. The notches on both sides of FPC are held by the lock lever, generating a high FPC retention force in spite of the small contact. (Fig.4)

5. Visual inspection on the mated status of FPC/FFC is possible.

- As the notches on both sides of FPC can be checked from the top surface after inserting FPC/FFC, insufficient insertion during assembly is prevented. (Fig.5)

6. Environmental

- Halogen free
- *AS defined by IEC 61249-2-21.
Br : 900ppm max, Cl : 900ppm max, Br+Cl : 1,500ppm max

Two-point contact design for dust prevention

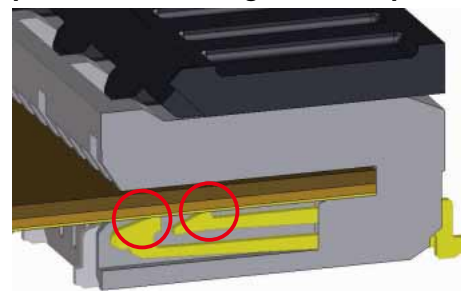

Fig.2

Supports FPC/FFC/Shield FFC



FPC FFC Shield FFC

Shielded FFC is acceptable for EMI prevention.

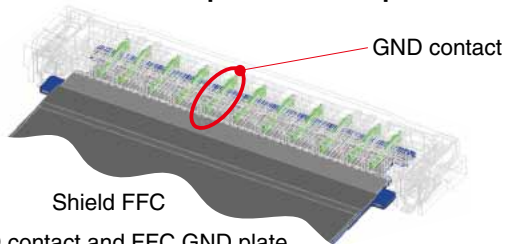

GND contact and FFC GND plate contact at multiple points.

Fig.3

FPC/FFC can be checked from the top surface after mating.

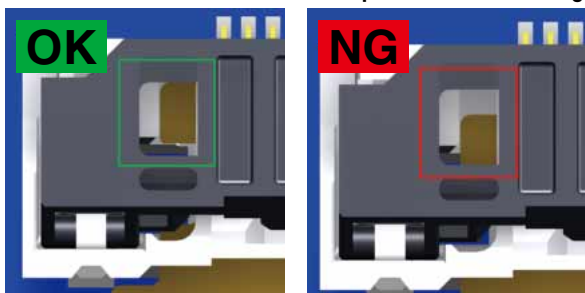

Mated condition (correct position)

Insufficient insertion condition (incorrect position)

Fig.5

High FPC retention force

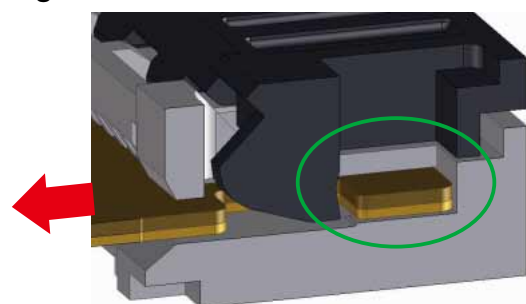

Robust lock firmly retains FPC/FFC.

Fig.4

Product Specifications

Rating	Rated current 0.5A Rated voltage 50V AC/DC rms	Operating temperature range : -55°C to +105°C (Note 1) Operating humidity range : Relative humidity 90% max. (No condensation)	Storage temperature range : -10°C to +60°C (Note 2) Storage humidity range : Relative humidity 90% max. (No condensation)
Adaptive FPC contact specifications	Thickness : = 0.33 ± 0.03mm Signal layout : Gold plated, GND plate : Tin plated		
Item	Specification	Conditions	
1. Insulation resistance	500MΩ min.	100V DC	
2. Withstanding voltage	No flashover or insulation breakdown	150V AC rms / 1 minute	
3. Contact resistance	100mΩ max. * Including FPC/FFC conductor resistance	1mA AC	
4. Durability (insertion / withdrawal)	Contact resistance : 100mΩ max. No damage, cracks, or parts dislocation	10 cycles	
5. Vibration	No electrical discontinuity of 1μs or more Contact resistance : 100mΩ max. No damage, cracks, or parts dislocation	Frequency : 10 to 55Hz, single amplitude of 0.75mm, 10 cycles in each of the 3 directions	
6. Shock	No electrical discontinuity of 1μs or more Contact resistance : 100mΩ max. No damage, cracks, or parts dislocation	Acceleration of 981m/s ² , duration of 6 ms, sine half-wave waveform, 3 cycles in each of the 3 axes	
7. Damp heat (Steady state)	Contact resistance : 100mΩ max. Insulation resistance : 50MΩ min. No damage, cracks, or parts dislocation	96 hours at temperature of 60°C and humidity of 90% to 95%	
8. Temperature cycle	Contact resistance : 100mΩ max. Insulation resistance : 50MΩ min. No damage, cracks, or parts dislocation	Temperature : -55°C → +15°C to +35°C → +105°C → +15°C to +35°C Time : 30 → 2 to 3 → 30 → 2 to 3 (Minutes) 5 cycles	
9. Resistance to soldering heat	No deformation of components affecting performance	Reflow : Recommended Temperature Profile Manual soldering: 350 ± 10°C for 5 seconds	

Note 1 : Includes temperature rise caused by current flow.

Note 2 : The term “storage” refers to products stored for long period of time prior to mounting and use. Operating Temperature Range and Humidity Range covers non-conducting condition of installed connectors in storage, shipment or during transportation.

Materials / Finish

Part	Materials	Finish	UL standard
Insulator	LCP	Grey	UL94V-0
	LCP	Black	UL94V-0
Signal contact	Copper alloy	Nickel barrier gold plated	—————
Grounding contact	Copper alloy	Pure tin reflow plated	—————
Reinforcing metal tabs	SUS	Pure tin reflow plated	—————

Product Number Structure

Refer to the chart below when determining the product specifications from the product number.
Please select from the product numbers listed in this catalog when placing orders.

FH 63 – 30S – 0.5 SH (99)

① ② ③ ④ ⑤ ⑥

① Series name : FH	⑤ Terminal type SH ... SMT horizontal mounting type
② Series No. : 63	
③ No. of contacts : 30	⑥ Specification Blank : Standard 3,500pcs/reel (99) : 500pcs/reel
④ Contact pitch : 0.5mm	

Connector Dimensions

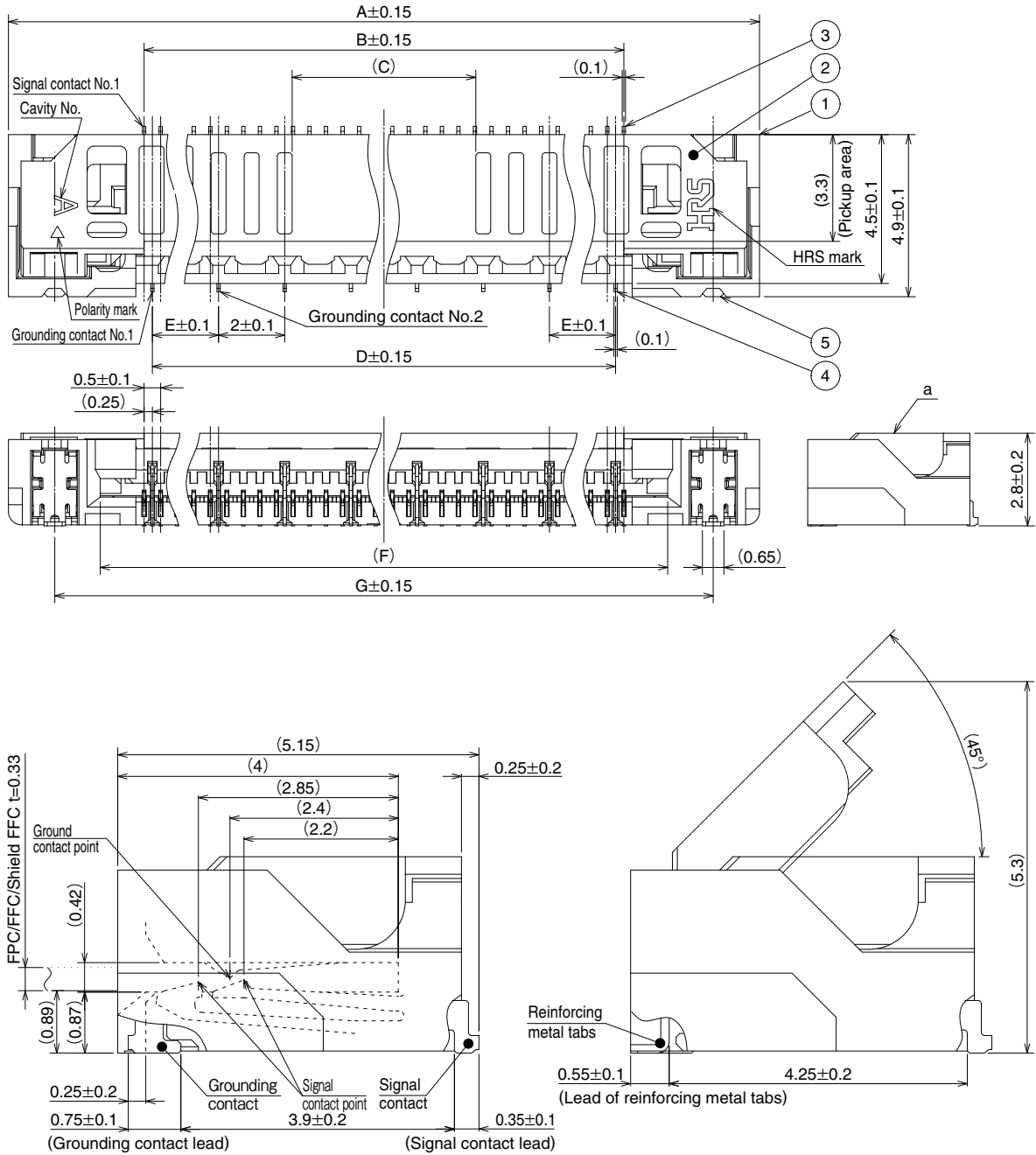

Note

- 1 : The dimension in parentheses are for reference.
- 2 : Lead co-planarity including reinforced chucking metals shall be 0.1 max.
- 3 : To be delivered with tape and reel packages.
See the packaging specifications for details.
- 4 : Note that preventive hole for sink mark or slit could be added for improvement.
- 5 : The quality remains good, even with the dark spots, which could occasionally occur on molded plastic.
- 6 : This product satisfies halogen free requirements defined as 900ppm maximum chlorine, 900ppm maximum bromine, and 1500ppm maximum total of chlorine and bromine.

Unit : mm

Part No.	HRS No.	No. of Contacts	A	B	C	D	E	F	G
FH63-10S-0.5SH	Under planning (Note 1)	10	12.7	4.5	5.55	4	2	7.15	9.9
FH63-20S-0.5SH	Under planning (Note 1)	20	17.7	9.5	6.55	9	1.5	12.15	14.9
FH63-30S-0.5SH	580-4400-0 **	30	22.7	14.5	5.55	14	2	17.15	19.9
FH63-40S-0.5SH	580-4403-0 **	40	27.7	19.5	10.55	19	1.5	22.15	24.9
FH63-50S-0.5SH	Under planning (Note 1)	50	32.7	24.5	15.55	24	2	27.15	29.9
FH63-60S-0.5SH	Under planning (Note 1)	60	37.7	29.5	20.55	29	1.5	32.15	34.9

Note 1 : Contact positions without HRS No. are currently under planning.
Please contact hirose for detailed information about product variation.

◆ Recommended PCB Mounting Pattern

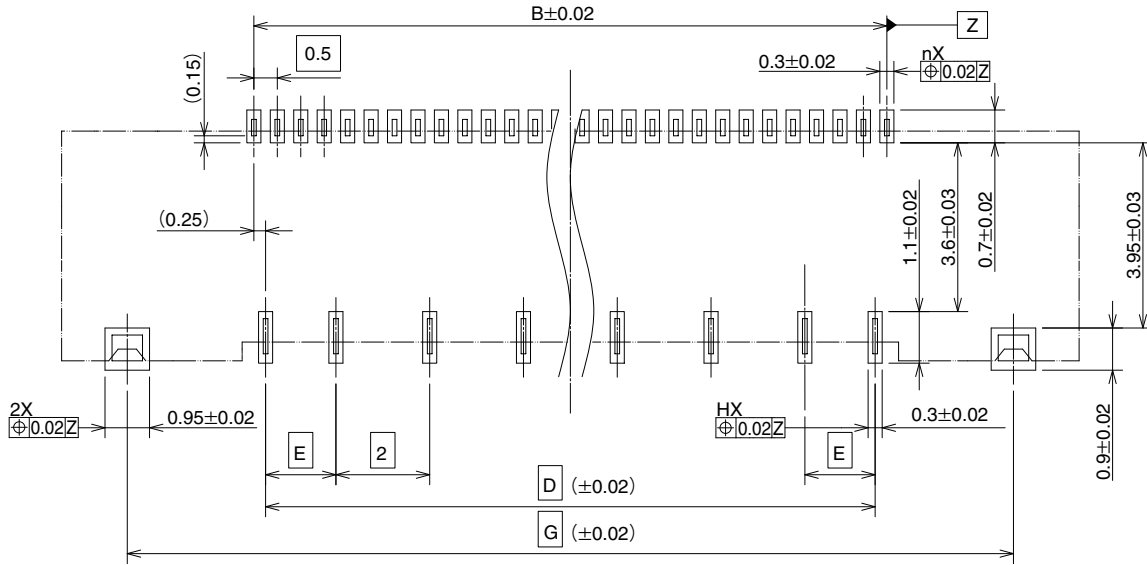

◆ Recommended Stencil Pattern

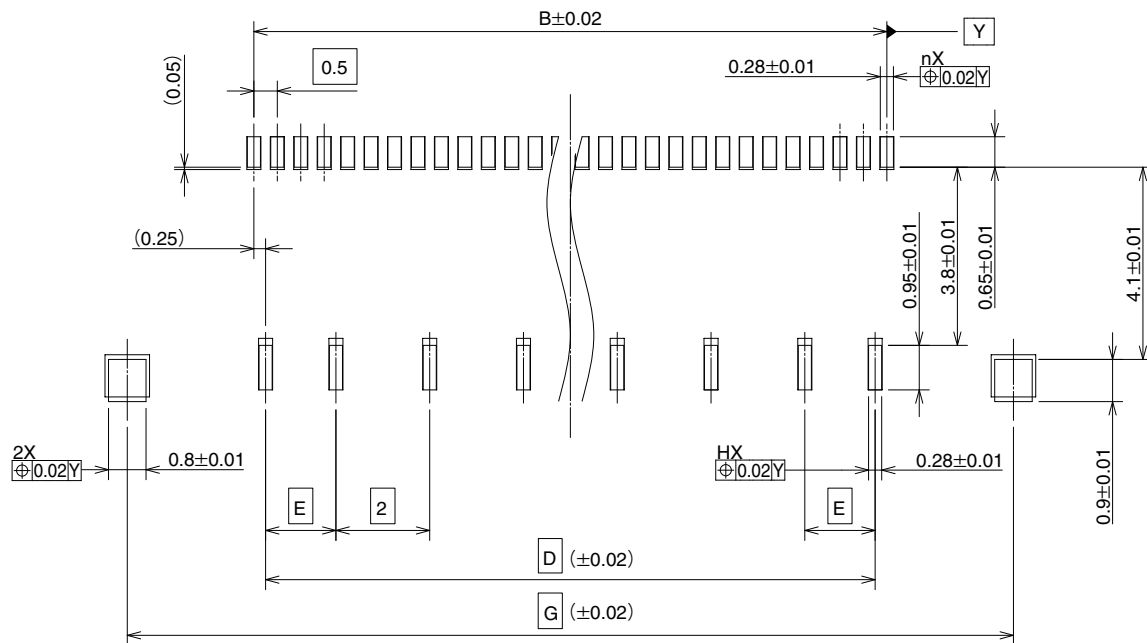

Note 7 : 'n' shows the number of contacts.

◆ Recommended Dimensions of PCB Mounting Pattern and Stencil Pattern

Units : mm

Part No.	HRS No.	No. of Contacts	B	D	E	G	H
FH63-10S-0.5SH	Under planning (Note 1)	10	4.5	4	2	9.9	3
FH63-20S-0.5SH	Under planning (Note 1)	20	9.5	9	1.5	14.9	6
FH63-30S-0.5SH	580-4400-0 **	30	14.5	14	2	19.9	8
FH63-40S-0.5SH	580-4403-0 **	40	19.5	19	1.5	24.9	11
FH63-50S-0.5SH	Under planning (Note 1)	50	24.5	24	2	29.9	13
FH63-60S-0.5SH	Under planning (Note 1)	60	29.5	29	1.5	34.9	16

Note 1 : Contact positions without HRS No. are currently under planning.
Please contact hirose for detailed information about product variation.

Recommended FPC/FFC Dimensions

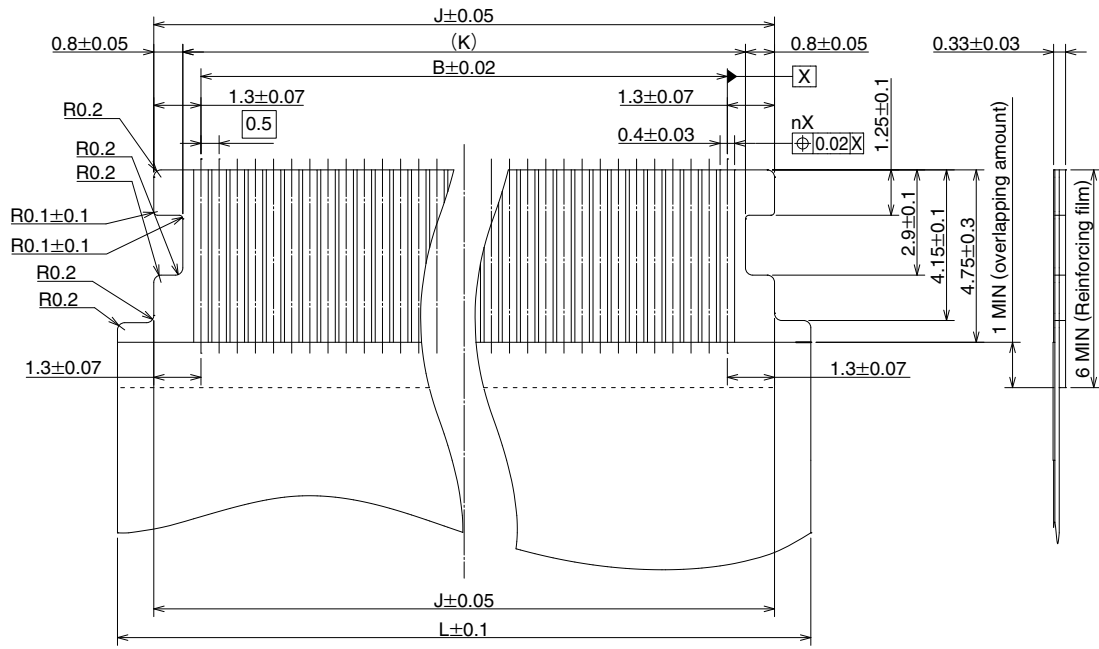

Recommended Shield FFC Dimensions

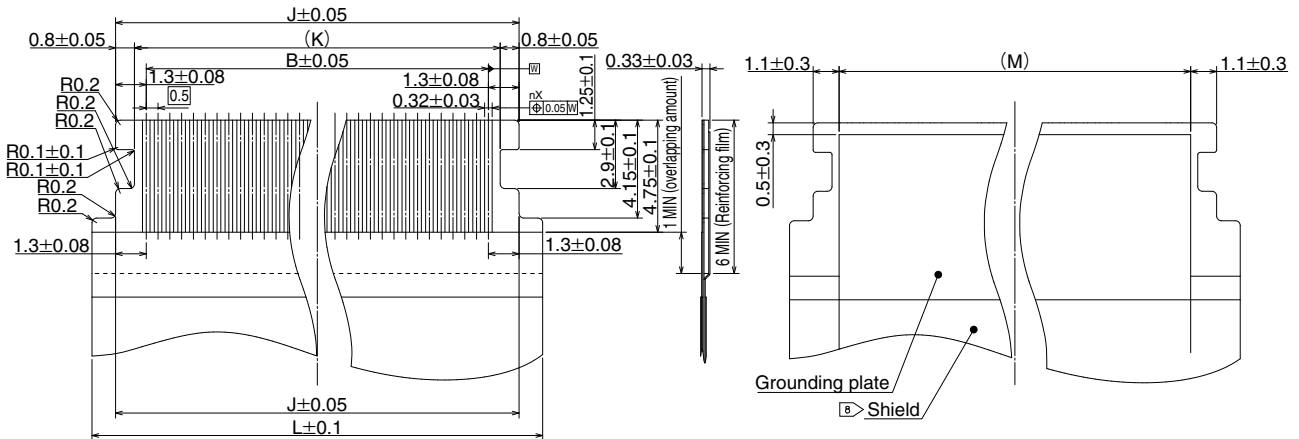

Note 7 : The value 'n' indicates the number of pos.
 8 Overlap the shield on the grounding plate.

Recommended Dimensions of FPC/FFC/Shield FFC

Units : mm

Part No.	HRS No.	No. of Contacts	B	J	K	L	M
FH63-10S-0.5SH	Under planning (Note 1)	10	4.5	7.1	5.5	9.1	4.9
FH63-20S-0.5SH	Under planning (Note 1)	20	9.5	12.1	10.5	14.1	9.9
FH63-30S-0.5SH	580-4400-0 **	30	14.5	17.1	15.5	19.1	14.9
FH63-40S-0.5SH	580-4403-0 **	40	19.5	22.1	20.5	24.1	19.9
FH63-50S-0.5SH	Under planning (Note 1)	50	24.5	27.1	25.5	29.1	24.9
FH63-60S-0.5SH	Under planning (Note 1)	60	29.5	32.1	30.5	34.1	29.9

Note 1 : Contact positions without HRS No. are currently under planning.
 Please contact hirose for detailed information about product variation.

Material composition of FPC/FFC/Shield FFC (Recommended specifications)

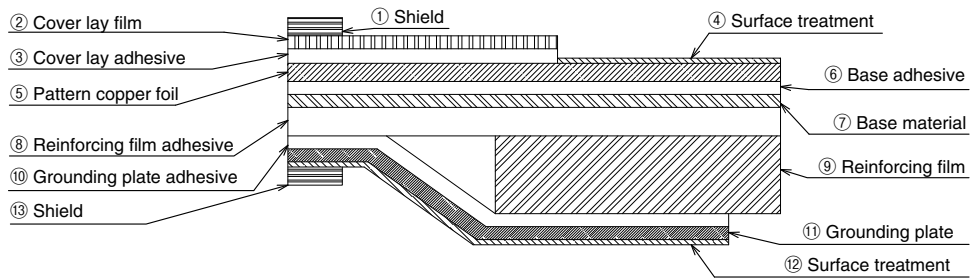

	Material name	FPC		FFC		
		Materials	Thickness (μm)	Materials	Shield FFC Thickness (μm)	FFC Thickness (μm)
①	Shield tape	—	—	—	—	—
②	Cover lay film	Polyimide 1mil	25	Polyester	25	25
③	Cover lay adhesive	Thermosetting adhesive	28	Adhesive	25	25
④	Surface treatment	Nickel foundation 1 to 6μm + Gold plated 0.2μm	(3.7)	Nickel foundation 0.5 to 5μm + Gold plated 0.05 to 1μm	(3.275)	(3.275)
⑤	Pattern copper foil	Rolled copper 1oz	35	Annealed copper foil	35	35
⑥	Base adhesive	Thermosetting adhesive	8	Adhesive	25	25
⑦	Base material	Polyimide 1mil	25	Polyester	25	50
⑧	Reinforcing film adhesive	Thermosetting adhesive	55	Adhesive	30	30
⑨	Reinforcing film	Polyimide 8mil	200	Polyester	150	188
⑩	Grounding plate adhesive	—	—	Adhesive	30	—
⑪	Grounding plate	—	—	Conductive tape Tin plated 1 to 5μm	37	—
⑫	Surface treatment	—	—	—	—	—
⑬	Shield tape	—	—	—	—	—

3. Caution

1. This specification is recommendation for the construction of the FH63 series FPC/FFC/Shield FFC (t=0.33±0.03mm)
2. For details about the construction, please contact FPC/FFC/Shield FFC manufactures.

◆ Packaging Specifications

● Embossed Carrier Tape Dimensions

tape width 24mm or less

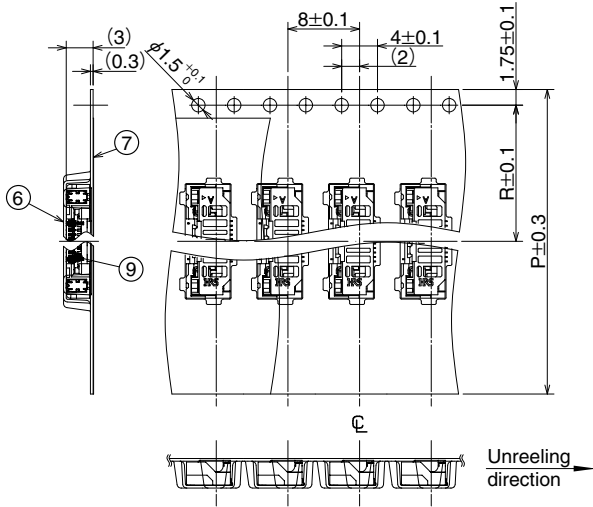

tape width 32mm or less

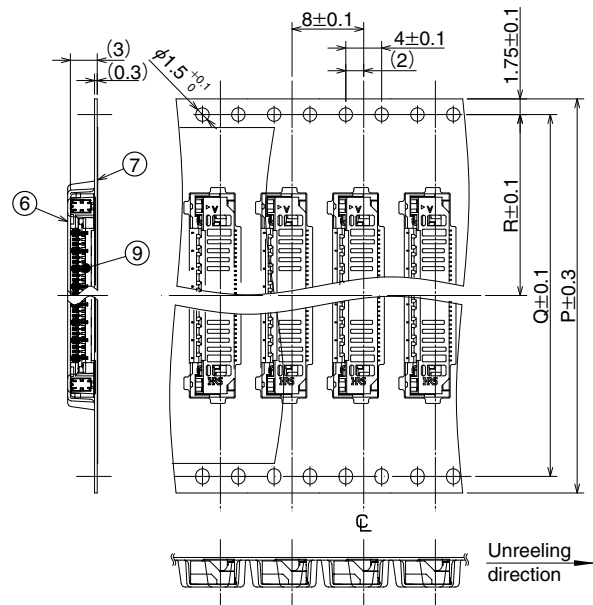

● Reel Dimensions

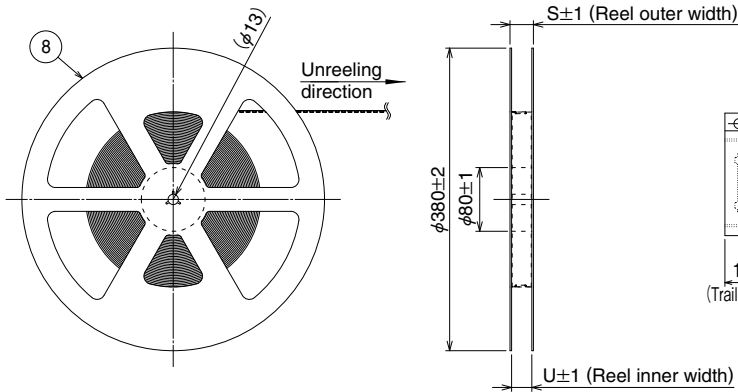

● Leader, Trailer Dimensions

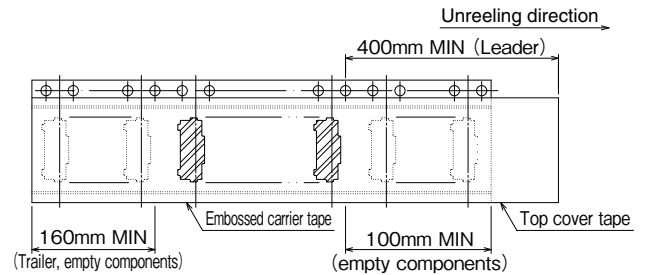

Note 9 : 3500 pieces shall be packaged in one reel. (For standard products)

Note 10 : The package complies with JIS C 0806 and IEC 60286-3 (Packaging of automotive mounting parts).

Unit : mm

Part No.	HRS No.	No. of Contacts	P	Q	R	S	U
FH63-10S-0.5SH	Under planning (Note 1)	10	24	—	11.5	29.4	25.4
FH63-20S-0.5SH	Under planning (Note 1)	20	32	28.4	14.2	37.4	33.4
FH63-30S-0.5SH	580-4400-0 **	30	44	40.4	20.2	49.4	45.4
FH63-40S-0.5SH	580-4403-0 **	40	44	40.4	20.2	49.4	45.4
FH63-50S-0.5SH	Under planning (Note 1)	50	56	52.4	26.2	61.4	57.4
FH63-60S-0.5SH	Under planning (Note 1)	60	56	52.4	26.2	61.4	57.4

Note 1 : Contact positions without HRS No. are currently under planning.

Please contact hirose for detailed information about product variation.

◆ Temperature Profile

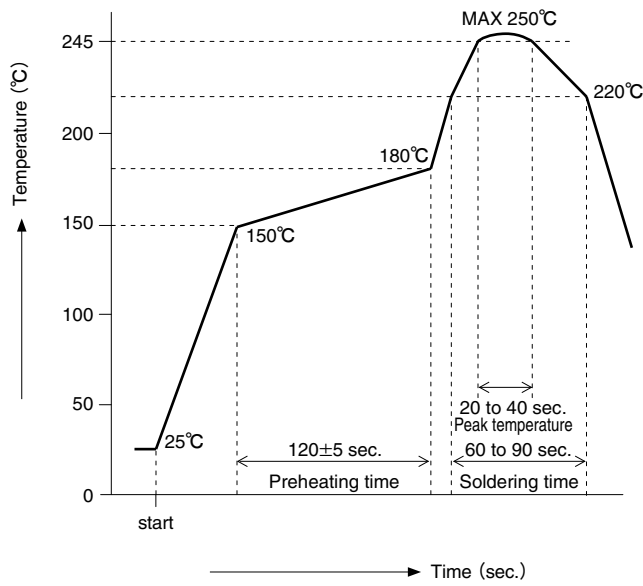

Applicable Conditions

- Reflow method : IR/Hot air
- Reflow environment : Room air
- Solder : Paste type Sn/3.0Ag/0.5Cu
(M705-GRN360-K2-V made by Senju Metal Industry Co.)
- Test PCB : PCB material and size
Glass epoxy 45×25×1mm
Land size, per recommended on page 4.
- Metal mask : Thickness and opening size
Per recommended on page 4.

This temperature profile is based on the above conditions. It may vastly depending on solder paste type, manufacturer, PCB size and mounting materials. Please use only after checking the mounting conditions.

◆ Connector operation and points to note

[Operation method]

Care needs to be taken when handling this connector. In order to prevent the damage and contact failure etc. (incorrect mating, disconnection of FPC pattern) of connectors and FPC, please use after confirming the following contents.

This connector supports FPC/FFC/Shield FFC, however, for convenience, the description is made only for FPC.

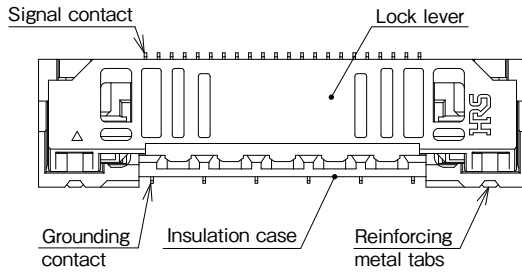

(Diagram of the connector's top surface)

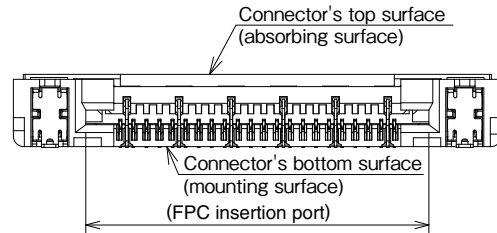

(Diagram of the connector's front surface)

1. Delivered state

This product is delivered with the lock lever closed. The lock lever does not need to be operated before inserting FPC.

[Caution]

- Do not open the lock lever when FPC is not inserted.
Additionally, the lock lever does not need to be opened except to remove the FPC. (Example 1)
- Do not operate the connector until it is mounted on the board. (Example 1)

– Delivered state –

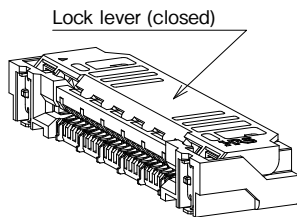

(Example 1)

NG

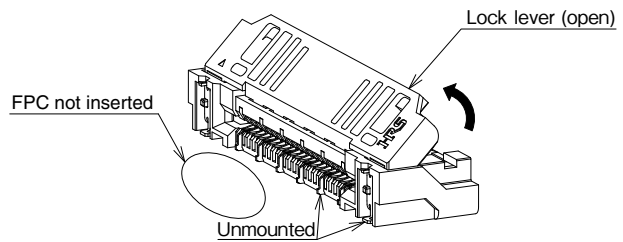

◆ Connector operation and points to note

[Operation method]

2. How to insert FPC

Insert FPC to the end correctly (Ex.2) horizontal to the board surface.

[Caution]

- Please confirm that the lock lever is closed when you insert FPC.
Do not insert FPC while the lock lever is open. (Example 3)
- Do not FPC while at the same time pressing the lock lever. (Example 4)
- Insert FPC straight after positioning its tip end in a horizontal plane in reference to the guides on both ends of the connector mating port.
- Insert in a manner that it won't be diagonal to the insertion direction. (Example 5)
- When inserting, do not move the FPC in a vertical, lateral or diagonal direction. (Example 6)

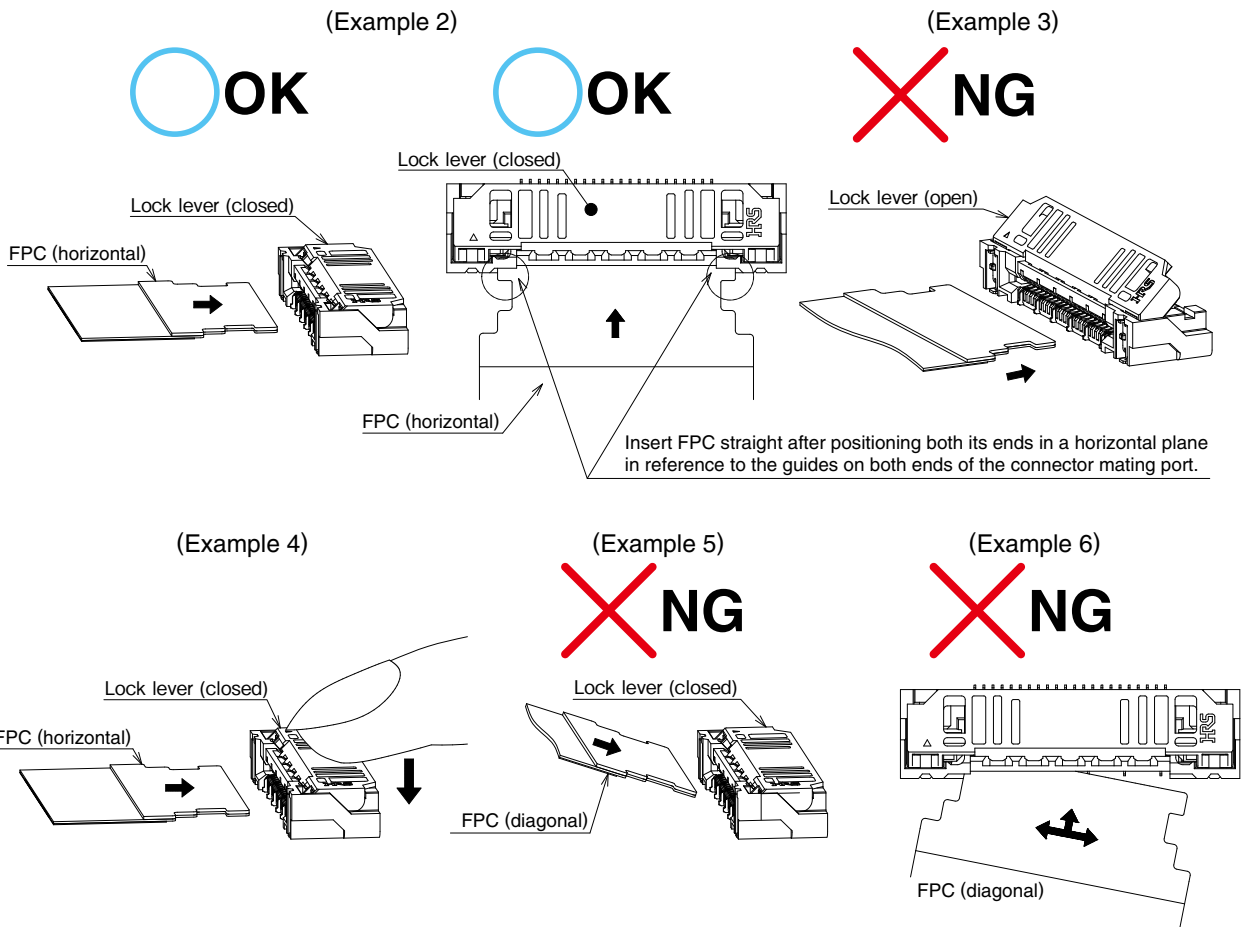

◆ Connector operation and points to note

[Operation method]

3. Confirming the mated state of FPC

When FPC is completely inserted, visually inspect the inserted status of FPC. (Example 7)
 (This connector uses the lock protrusion of the lock lever for positioning FPC.)

[Caution]

- FPC is not inserted deep enough or in a diagonal direction. (Example 8)(Example 9)
- Because of the single action lock, The lever does not need to be operated after inserting FPC.

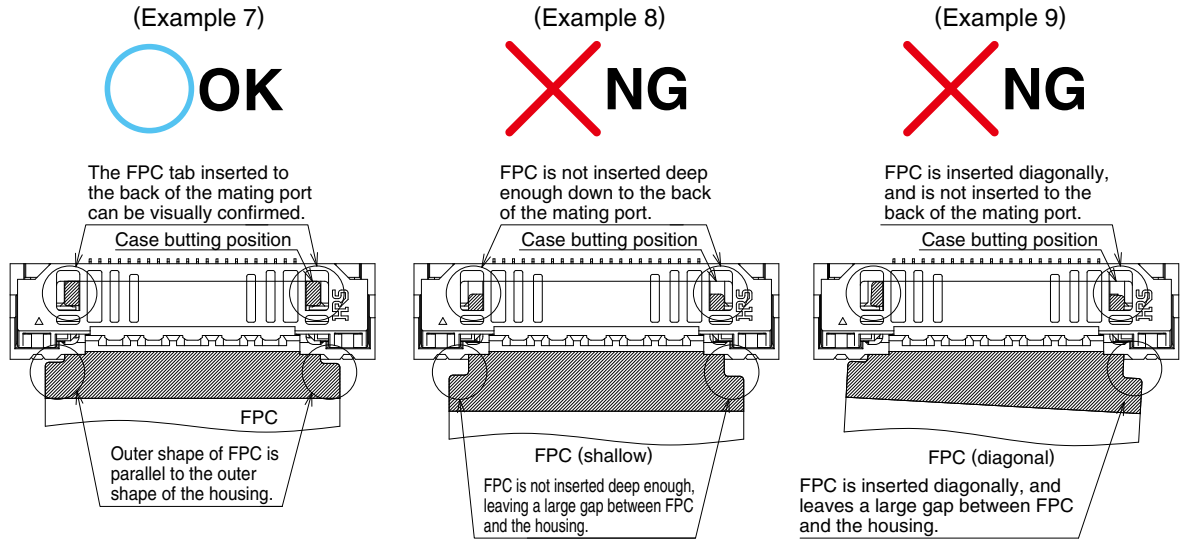

– Cross section of the lock section – – Cross section of the lock section – – Cross section of the lock section –

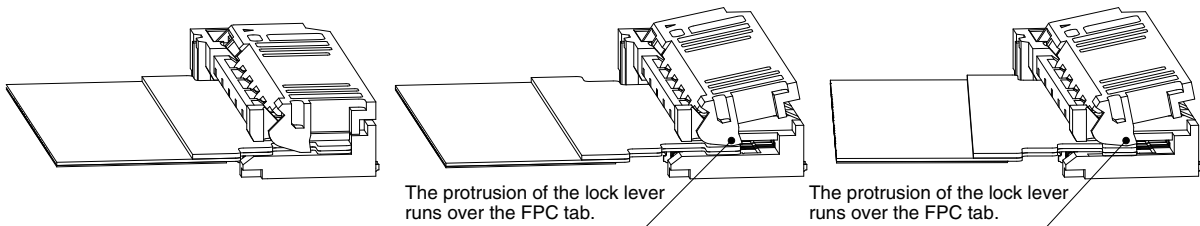

◆ Connector operation and points to note

[Operation method]

4. How to unlock the lock lever

Push up the lock lever slowly, and release the lock. (Example 10)

[Caution]

- When releasing the lock, operate the lock lever around the center. (Example 11)
- When releasing the lock, do not operate only one side of the lock lever. (Example 12)
- As the lock lever cannot be opened to over 45°, do not open it over this angle. (Example 13)
- Do not pick and raise the lock lever off, or pull it. (Example 14)
- Be sure to operate the lock lever by hand, and do not operate it with sharp-edged tools such as tweezers etc. (Example 15)
- Don't apply an excessive force to the housing during operation. (Example 16)
- The FPC insertion direction for this connector is different from the direction of the lock lever operation section. Do not try to open FPC from its insertion side. (Example 17)

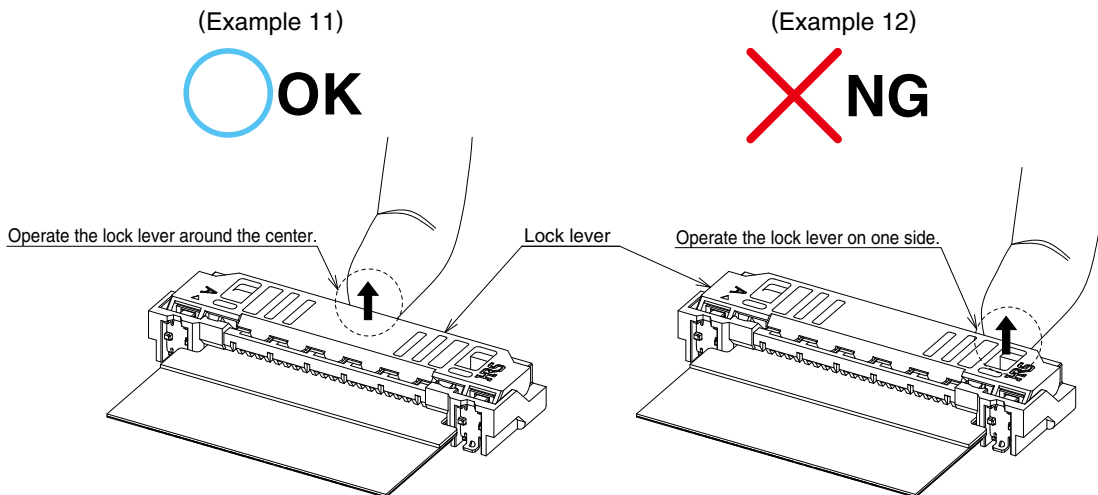
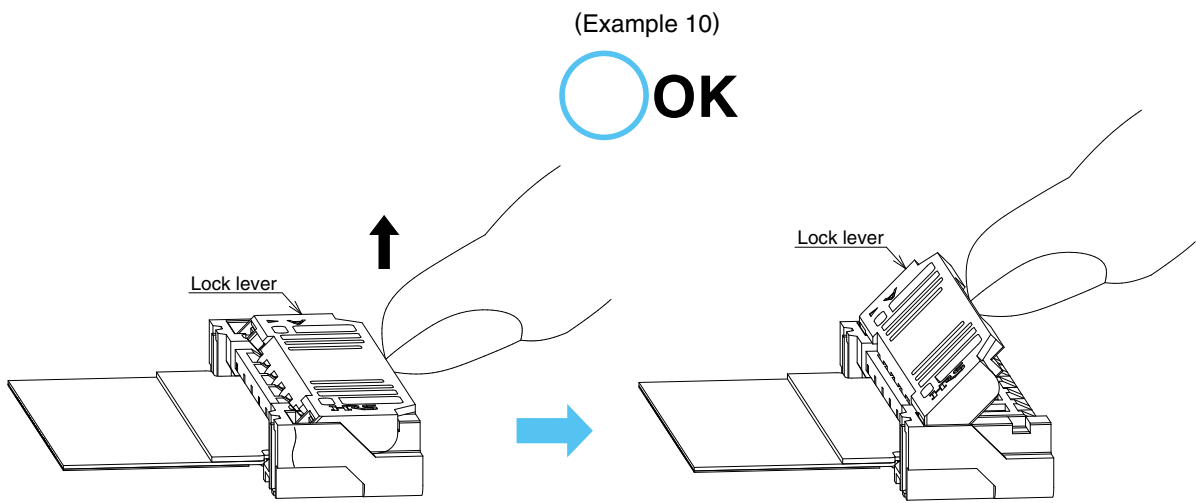

◆ Connector operation and points to note

[Operation method]

(Example 13)

NG

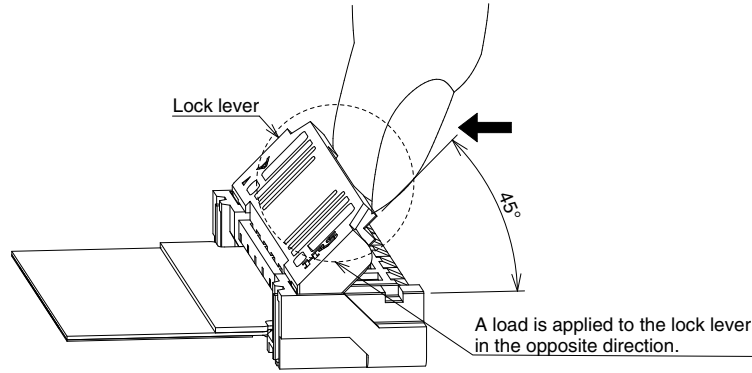

(Example 14)

NG

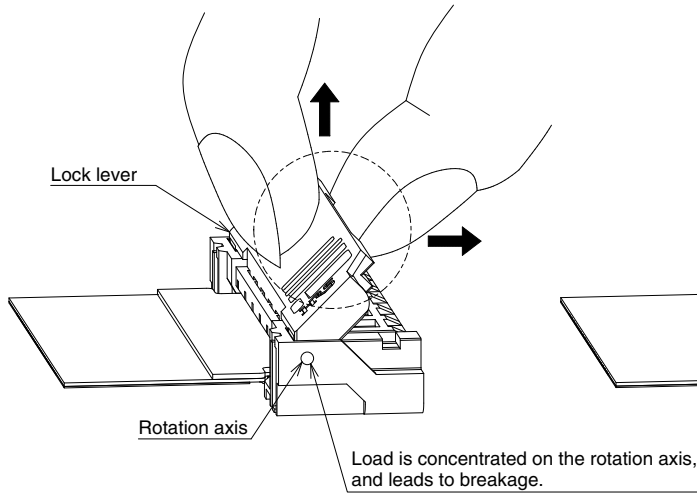

(Example 15)

NG

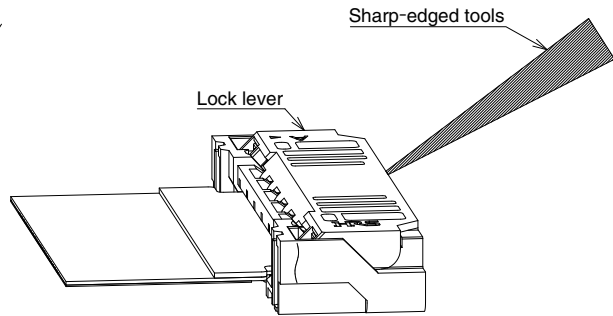

(Example 16)

NG

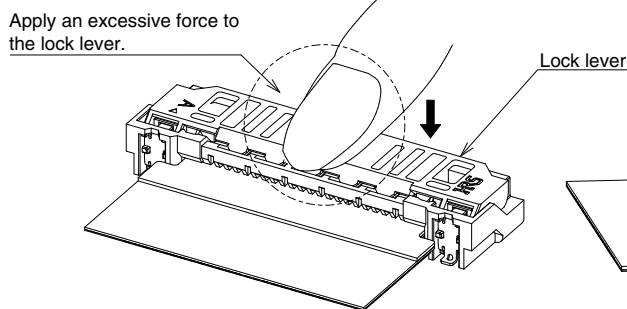

(Example 17)

NG

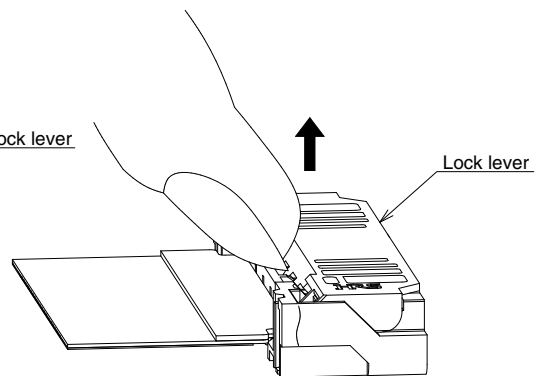

Dec.1.2018 Copyright 2018 HIROSE ELECTRIC CO., LTD. All Rights Reserved.

◆ Connector operation and points to note

[Operation method]

5. How to remove FPC

After releasing the lock lever, remove the FPC in the horizontal direction. (Example 18)

When removing the FPC, do not press the lock lever. (Example 19)

As the released lock lever automatically closes when removing the FPC, the lever does not need to be operated after removal. (Example 20)

[Caution]

- Do not pull out FPC while the lever is locked. (Example 21)
- This connector is equipped with the FPC retention mechanism by means of the lock lever. When pulling out FPC, do not apply load in the upward or lateral direction. (Example 22)

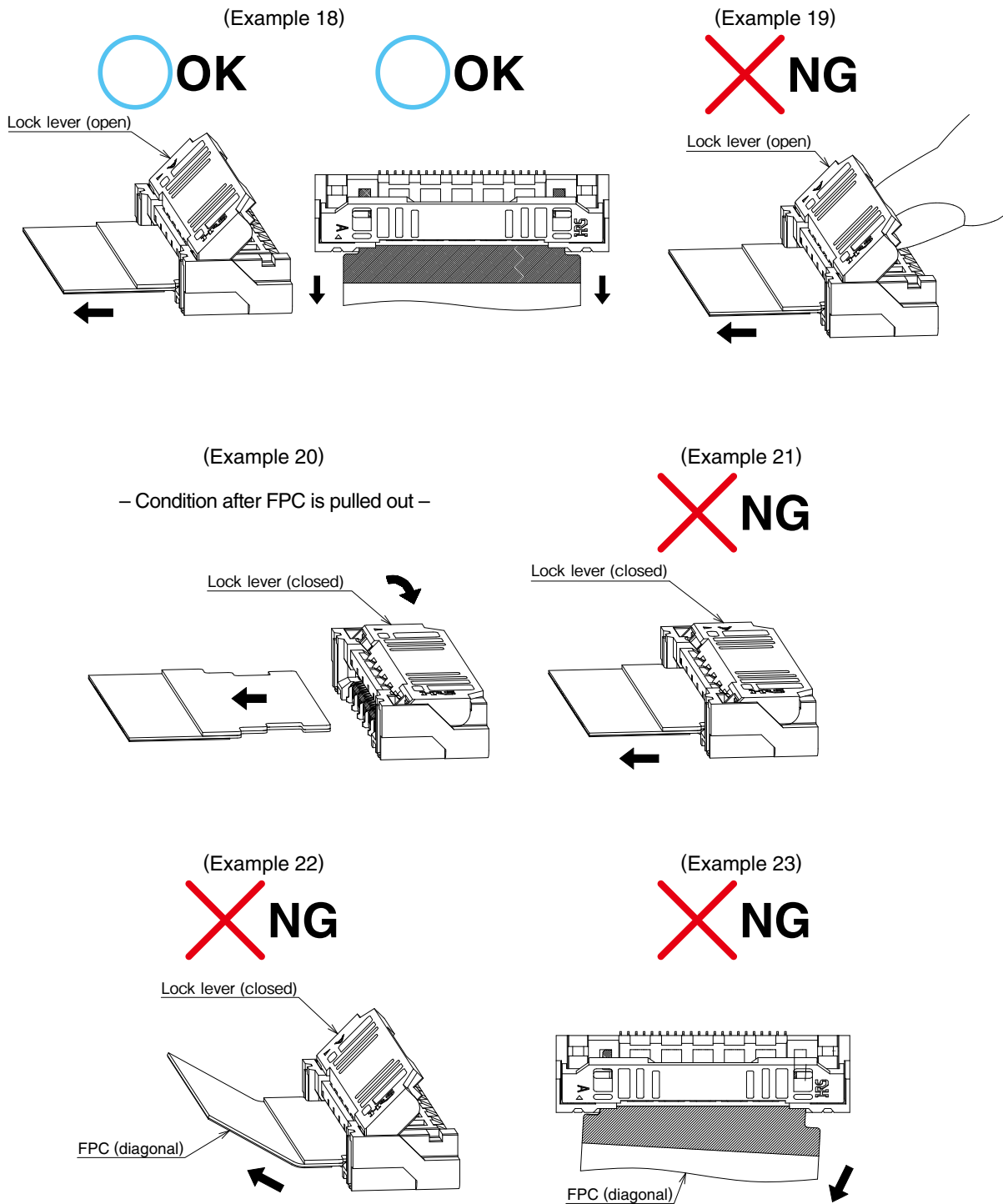

◆ Connector operation and points to note

[Operation method]

[Cautions for PCB layout]

Depending on the routing of FPC to mate, a load may be applied to the connector, which could lead to failure. In order to prevent failure, please consider the following concerning the mechanism design.

[Caution]

- When routing the FPC, please be careful that FPC is not pulled and routing is carried out with a margin.
- Please check that the reinforcing film is placed horizontal to the board surface. (Example 23)
- Please insure there is no load applied to the connector in the pulling, inserting or lateral direction.
A bent FPC, it could cause contact failure or damage/disconnection of FPC. Therefore, please take some measure to fix FPC etc. (Example 24)(Example 25)
- Don't place any parts under the FPC that will interfere with FPC. (Example 26)
- As for the flexibility of FPC, please make adjustments with the FPC manufacturer.
- Please ensure the FPC has adequate insertion space when designing the layout so that it is not inserted diagonally.
Additionally, ensure the insertion space is not too short for FPC. Please adopt adequate parts layout and length for FPC.
- When you design the board/layout, please secure a space required for operations.

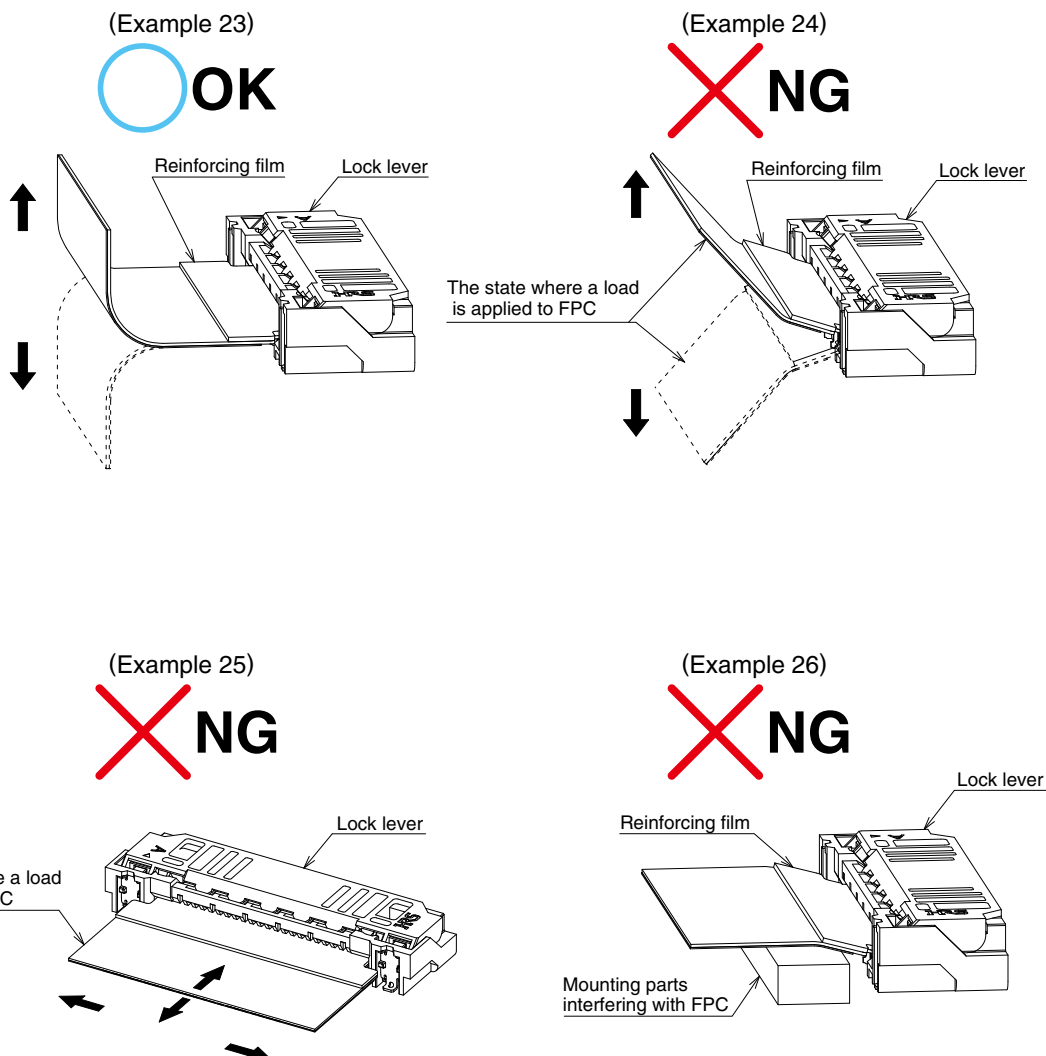

◆ Connector operation and points to note

[Notes for mounting on the board/after mounting on the board]

[Notes for mounting on the board]

Please be careful of the following at the time of board mounting.

[Caution]

- Please confirm recommendations for mount board land shape, metal mask opening shape, and FPC shape.
- If the land is narrower than recommend, or if the metal mask opening is wider than recommend, solder (flux) wicking is more likely to occur.
If there is difference from the recommendation, please use check the mounted state.
- The level difference between the bottom surfaces of contact lead and the mold is designed to be small. When there is silk print etc. on the bottom surface of the connector, it could push up the connector bottom surface, and cause non-sticking solder or defective fillet formation.
When there is silk print etc. on the bottom surface of the connector, please use it after checking the mounted state.
- Use the reflow conditions within the specifications of our company.
The mounted status may vary due to external conditions such as the type of cream solder, manufacturer, and board size. Please use it after checking the mounted state.
- Please control the board warpage as much as possible. While the coplanarity of this connector is 0.1mm or less, defective soldering could occur if the board warpage is considerable.
- When mounted on FPC, be sure to provide a reinforcing plate to ease handling. We recommend a reinforcing plate of 0.3mm or thicker made of glass epoxy material.
- When pulling out the emboss from the reel, or when the connector is absorbed from the emboss and so on, do not apply any excessive external force (of 1N or more) to the connector before mounting.

[Cautions when handling the board after mounting]

Please be careful of the following when handling the board after mounting operation.

[Caution]

- Do not apply any load to the board in the assembly process, such as "dividing a multi-piece board" or "securing the board to the frame".
Such action could apply a load to the connector and damage it.
- Use the board with the deflection being 1mm or less when the board width is 100mm. (Example 27)
If the board has some deflection, it could apply a load to the connector and damage it.

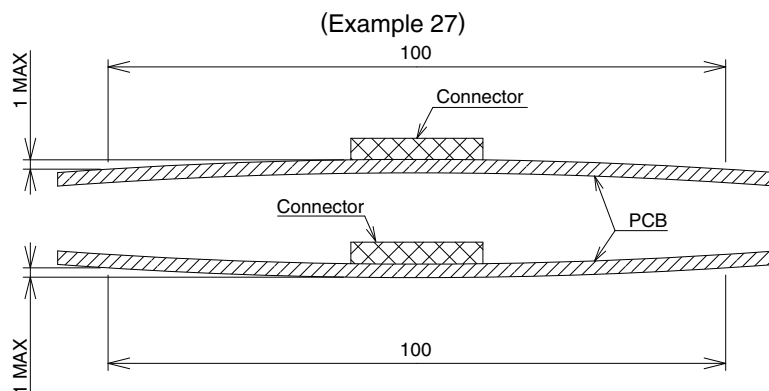

[Cautions for hand-soldering]

Please be careful of the following when hand-soldering for repair work etc.

[Caution]

- Do not hand-solder while FPC is inserted.
- Please be careful not to apply excessive heat, or allow the solder iron to touch any place other than the connector contact lead.
Such action could cause the connector to be deformed or melted.
- Do not supply an excessive amount of solder (flux).
If too much solder (flux) is supplied to the contact, the solder or flux could adhere on the contact point and cause contact failure.
Additionally, if you supply too much solder to the reinforcing metal tabs the rotational action of the lock lever could be defective and the connector could be damaged.



HIROSE ELECTRIC CO.,LTD.

2-6-3,Nakagawa Chuoh,Tsuzuki-Ku,Yokohama-Shi 224-8540,JAPAN

TEL: +81-45-620-3526 Fax: +81-45-591-3726

<http://www.hirose.com>

<http://www.hirose-connectors.com>

X-ON Electronics

Largest Supplier of Electrical and Electronic Components

Click to view similar products for [FFC & FPC Connectors](#) category:

Click to view products by [Hirose](#) manufacturer:

Other Similar products are found below :

[HFW11R-1STE1H1LF](#) [FH29B-100S-0.2SHW\(99\)](#) [FA5S008HP1](#) [FH29B-120S-0.2SHW\(99\)](#) [FH29B-80S-0.2SHW\(99\)](#) [FHS-16](#) [FPH-2022G](#)
[52610-1075](#) [52610-1275](#) [52610-1934](#) [XF3M\(1\)-1415-1B-R100](#) [501864-3091-TR225](#) [0525594033](#) [086210010340800](#) [086222026001800](#)
[52271-2869-CUT-TAPE](#) [62674-201121DLF](#) [62684-36210E9ALF](#) [52610-1675](#) [52746-1671-TR250](#) [10051922-2810EHLF](#) [6-520415-9](#)
[BD021-09A-A1-0350-0200-0550-LD](#) [SFV6R-1STE9HLF](#) [XF3M-2915-1B-R100](#) [1658549-1](#) [62674-221121ALF](#) [46214008010800](#)
[046298003000883](#) [151660622](#) [842-816-2630-035](#) [AYF530665TA](#) [AYF351525](#) [046296011930846+](#) [AYF352325A](#) [046254020000800+](#)
[FH19C-13S-0.5SH\(99\)](#) [FH39J-51S-0.3SHW\(99\)](#) [AYF355125A](#) [AYF530365TA](#) [FH29B-44S-0.2SHW\(99\)](#) [SFW5R-2STAE9LF](#) [AYF351125A](#)
[AYF350725A](#) [62684-502100AHLF](#) [FH39-61S-0.3SHW\(99\)](#) [AYF414035A](#) [10064555-172520HLF](#) [AYF212335A](#) [504754-2500](#)