



MachXO3-9400 Development Board

Evaluation Board User Guide

FPGA-EB-02004 Version 1.0

May 2017

Contents

Acronyms in This Document	5
1. Introduction	6
1.1. MachXO3-9400 Development Board	6
1.2. Features	7
1.3. MachXO3LF Device	8
1.4. L-ASC10 Device	8
2. Applying Power to the Board	9
3. JTAG/I ² C Programming	11
3.1. JTAG Download Interface	11
3.2. I ² C Download Interface	12
3.3. Alternate JTAG Download Interface	12
3.4. JTAG to MSPI Pass-through Interface	12
3.5. Other JTAG Configuration Pins	12
4. MachXO3 Clock Sources	13
5. Headers and Test Connections	14
5.1. Versa Headers	14
5.2. Arduino Board GPIO Headers	16
5.3. FX12 Headers (DNI)	18
5.4. Aardvark Header (DNI)	20
5.5. Raspberry Pi Board GPIO Header	21
6. I ² C and SPI Buses	23
6.1. I ² C Topology	23
6.2. SPI Topology	25
6.2.1. SPI Configuration	25
6.2.2. SPI Flash Access	25
7. LEDs and Switches	26
7.1. Four-Position DIP Switch	26
7.2. General Purpose Push Buttons	27
7.3. General Purpose LEDs	27
7.4. LVDS Outputs Pins	28
7.5. General Purpose DDR Outputs	29
8. ASC Connections	30
8.1. ASC Interface	30
8.2. ASC Voltage Monitor	30
8.3. ASC Current Monitor	31
8.4. ASC Temperature Monitor	32
8.5. ASC LEDs	33
8.6. ASC HVOUT and Trim Pins	33
9. Software Requirements	34
10. Storage and Handling	34
11. Ordering Information	34
References	35
Lattice Semiconductor Documents	35
Technical Support Assistance	36
Appendix A. MachXO3-9400 Development Board Schematics	37
Appendix B. MachXO3-9400 Development Board Bill of Materials	47
Appendix C. Predefined Preference File Listing	54
Appendix D. User Defined Preference File Listing	55
Revision History	60

Figures

Figure 1.1. Top View of MachXO3-9400 Development Board.....	6
Figure 1.2. Bottom View of MachXO3-9400 Development Board.....	7
Figure 2.1. Board Power Supply.....	9
Figure 3.1. JTAG/I ² C Programming Architecture	11
Figure 3.2. PTM Programming Mode	11
Figure 4.1. Optional Clock Circuit Design.....	13
Figure 5.1. Aardvark SS Pin Connections	20
Figure 6.1. I ² C Topology.....	23
Figure 6.2. I ² C MUX Circuits.....	24
Figure 7.1. Four-Position DIP Switch Circuits.....	26
Figure 7.2. Four-Position DIP Switch Photograph.....	26
Figure 7.3. Push Button SW5 Circuit Design	27
Figure 7.4. Board LEDs	28
Figure 8.1. POT Circuit Design for VMON7	31
Figure 8.2. POT Wiper Description	31
Figure 8.3. VCC Core Current Monitoring Circuit.....	32
Figure 8.4. PNP Temperature Sensor Circuit	32
Figure 8.5. NPN Temperature Sensor Circuit.....	32
Figure 8.6. ASC LEDs	33
Figure A.1. Title Page	37
Figure A.2. Block Diagram.....	38
Figure A.3. USB to JTAG I/F.....	39
Figure A.4. VERSA Headers (BANK0).....	40
Figure A.5. Arduino Headers (BANK1)	41
Figure A.6. CrossLink Headers (BANK2)	42
Figure A.7. Raspberry Pi Header and Others (BANK3, BANK4, BANK5).....	43
Figure A.8. Analog Sense and Control	44
Figure A.9. Power Decoupling and LEDs.....	45
Figure A.10. Power Regulators	46

Tables

Table 2.1. 5 V Sources and Connections	9
Table 2.2. MachXO3 Power Rail Options	10
Table 2.3. ASC Power Connections	10
Table 3.1. JTAG Connections.....	12
Table 3.2. Other JTAG Signals	12
Table 4.1. JTAG Connections.....	13
Table 5.1. Versa X2 Header Pin Connections	14
Table 5.2. Versa X3 Header Pin Connections	15
Table 5.3. Arduino J2 Pin Connections.....	16
Table 5.4. Arduino J3 Pin Connections.....	17
Table 5.5. Arduino J4 Pin Connections.....	17
Table 5.6. Arduino J5 Pin Connections.....	17
Table 5.7. FX12 U4 Header Pin Connections.....	18
Table 5.8. FX12 U5 Header Pin Connections.....	19
Table 5.9. Aardvark JP2 Header Pin Connections	20
Table 5.10. Raspberry Pi JP3 Header Pin Connections.....	21
Table 6.1. I ² C MUX Function	23
Table 6.2. I ² C Global Bus Connections	24
Table 6.3. MachXO3 SPI Connections	25
Table 6.4. MachXO3 SPI Configuration Options	25
Table 7.1. Four-Position DIP Switch Signals	26
Table 7.2. Push Button Switch Signals	27
Table 7.3. LED Signals	27
Table 7.4. LVDS Test Points.....	28
Table 7.5. GDDR Test Points	29
Table 8.1. ASC to MachXO3 Connections	30
Table 8.2. ASC VMON Connections.....	30
Table 8.3. ASC IMON Connections.....	31
Table 8.4. ASC TMON Connections	32
Table 8.5. GPIO LED Connections	33
Table 8.6. ASC HVOUT and Trim Connections	33
Table 11.1 Ordering Information	34

Acronyms in This Document

A list of acronyms used in this document.

Acronym	Definition
ASC	Analog Sense and Control
CMOS	Complementary Metal-Oxide Semiconductor
GDDR	Graphics Double Data Rate
FTDI	Future Technology Devices International
GPIO	General Purpose Input/Output
I ² C	Inter-Integrated Circuit
LVDS	Low-Voltage Differential Signaling
SPI	Serial Peripheral Interface

1. Introduction

The Lattice Semiconductor MachXO3-9400™ Development Board allows designers to investigate and experiment with the features of the MachXO3 complex programmable logic device (CPLD) and the L-ASC10 (L-Analog Sense and Control 10 rails) hardware management expander. The features of the MachXO3-9400 Development Board can assist engineers with the rapid prototyping and testing of their specific designs.

The MachXO3-9400 Development Board is part of the MachXO3-9400 Development Kit, which includes the following:

- MachXO3-9400 Development Board pre-loaded with the demo design
- Mini USB cable
- QuickStart Guide

This document is intended to be referenced in conjunction with demo user guides for MachXO3-9400. See the [References](#)

The contents of this user guide include top-level functional descriptions of the various portions of the development board, descriptions of the on-board headers, diodes and switches and a complete set of schematics.

1.1. MachXO3-9400 Development Board

Along with the MachXO3LF-9400 CPLD, the MachXO3-9400 Development Board also features an L-ASC10 device to enable designers to easily evaluate hardware management design and expand the usability of the MachXO3LF-9400 with Arduino, Raspberry, FX12, Versa and Aardvark headers.

[Figure 1.1](#) shows the top view of the MachXO3-9400 Development Board. [Figure 1.2](#) shows the bottom view of the board.

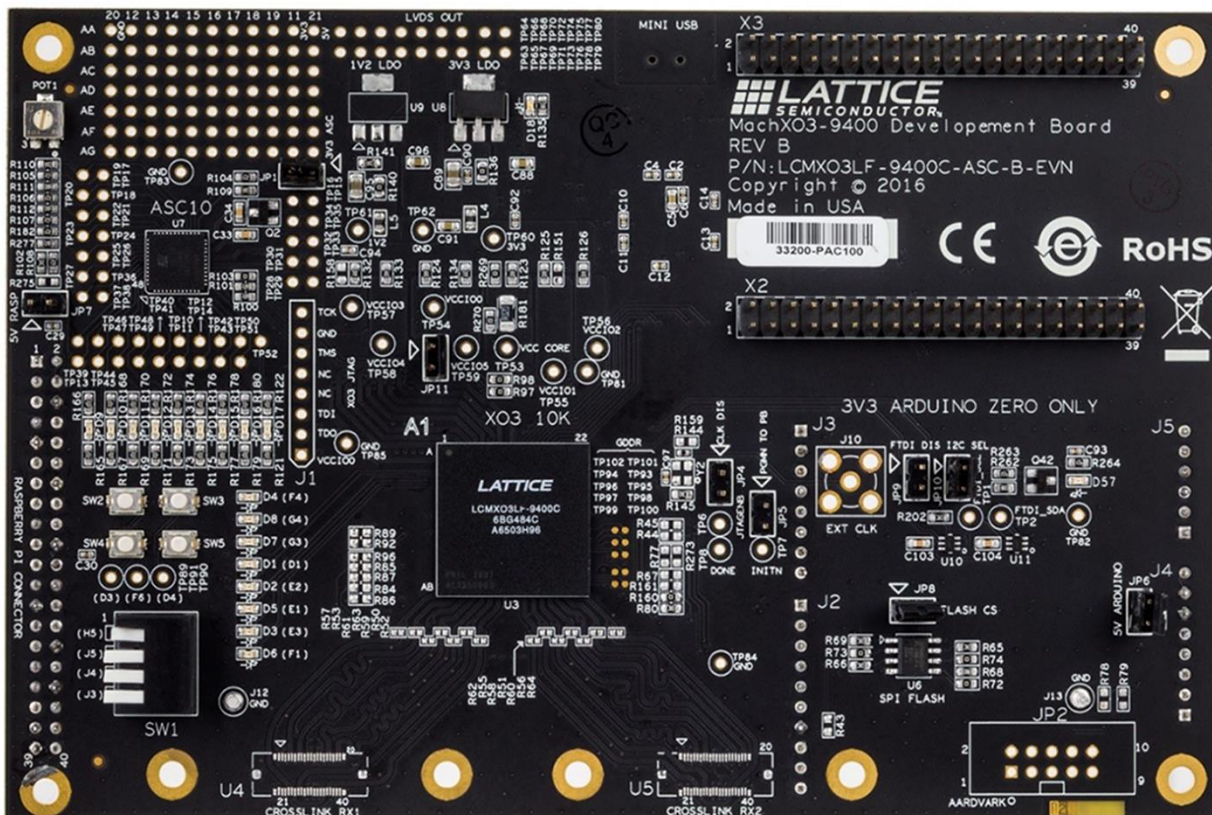

Figure 1.1. Top View of MachXO3-9400 Development Board

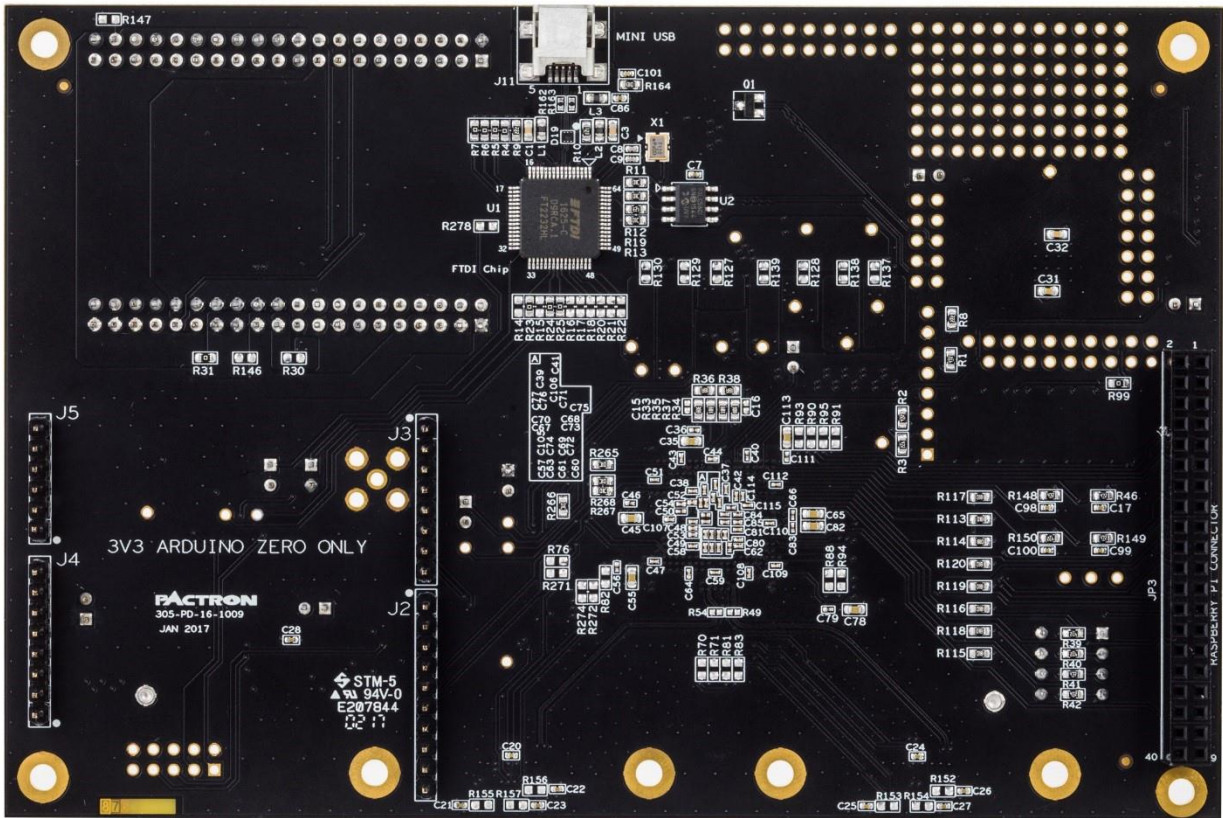

Figure 1.2. Bottom View of MachXO3-9400 Development Board

1.2. Features

- LCMXO3LF-9400C CPLD demonstration with L-ASC10 for simple hardware management including voltage, current and temperature monitoring
- General Purpose Input/Output (GPIO) interface with Arduino and Raspberry Pi boards
- USB-B connection for device programming and Inter-Integrated Circuit (I²C) utility
- On-board Boot Flash – 16 Mbit Serial Peripheral Interface (SPI) Flash, with Quad read feature for user’s application
- 4-position DIP Switches, 4 push buttons and 16 LEDs for demo purposes
- Diamond® programming support
- Multiple reference clock sources
- Two Hirose FX12-40 header positions (DNI)
- Aardvark header (DNI)

Note: DNI stands for “Do NOT Install” parts and DI stands for “Do Install” parts for assembly.

Caution: The MachXO3-9400 Development Board contains ESD-sensitive components. ESD safe practices should be followed while handling and using the development board.

1.3. MachXO3LF Device

The MachXO3-9400 Development Board features the MachXO3LF-9400 in 484-ball caBGA package. This MachXO3LF-9400 device (also referred to as LCMXO3LF-9400C) features 9400 LUTs and 432 kbits of embedded block RAM. This device offers a variety of features and programmability. For more information on the capabilities of MachXO3™, see DS1047, [MachXO3 Family Data Sheet](#).

1.4. L-ASC10 Device

The L-ASC10 (also referred to as ASC) is a Hardware Management (Power, Thermal, and Control Plane Management) Expander designed to be used with Platform Manager 2 or MachXO2/MachXO3 FPGAs to implement the Hardware Management Control function in a circuit board. The L-ASC10 enables seamless scaling of power supply voltage and current monitoring, temperature monitoring, sequence and margin control channels. ASC includes dedicated interfaces supporting the exchange of monitor signal status and output control signals with centralized hardware management controllers. For more information on the capabilities of ASC device see DS1042, [L-ASC10 Data Sheet](#).

2. Applying Power to the Board

The MachXO3-9400 Development Board is ready to power on with onboard Low Dropout (LDO) generators powered by an external 5 V power, as shown in Figure 2.1. The 5 V power can come from a USB connection (J11) and routed to multiple onboard headers listed Table 2.1. Note that the 5 V power path to headers should be manually connected using a zero-ohm resistor or jumper before power is applied to the mated board as outlined in Table 2.1.

Table 2.1. 5 V Sources and Connections

Header (Reference)	5 V Power Pins	5 V Power Path (Assembly)
USB header (J11)	1	L3 (DI)
FX12 header 1 (U4)	23, 38	R153 (DNI)
FX12 header 2 (U5)	23, 38	R155 (DNI)
Aardvark header (JP2)	4, 6	R78(DNI), R79 (DNI)
Arduino header (J4)	5	JP6 (DNI)
Raspberry Pi header (JP3)	2, 4	JP7 (DNI)
Versa header (X2)	21	R30 (DNI)

Warning: Avoid power conflict when the 5 V power path is enabled from the MachXO3-9400 Development Board to the mated board, Do Not apply 5V power from both boards when the path is manually shorted.

Conversely, 5 V power can be supplied from onboard headers if J11 is not connected to a USB cable. The power from the headers can be used to drive LDOs and other mated boards.

Aside from the 3.3 V LDO (U8) default power source for MachXO3 device (U3), the board provides additional LDO footprint (U9) for lower power applications. For example, TLV1117LV12DCY can be used for 1.2 V VCCIOs. Other SOT-223 footprint compatible LDOs from 1.2 V to 3.3 V can also be considered. VCCIO1 for Bank 1 and VCCIO3 for Bank 3 can likewise be supplied from mated boards. 3.3 V is used for better GPIO voltage alignment.

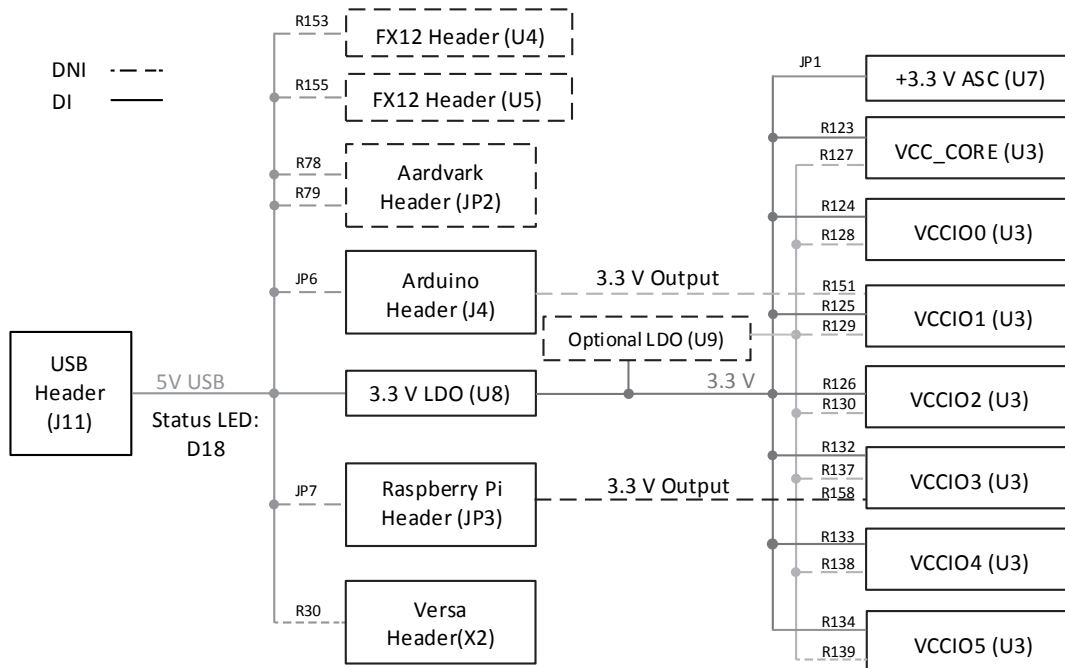

Figure 2.1. Board Power Supply

Table 2.2. MachXO3 Power Rail Options

MachXO3 Device Power (U3)	3.3 V Option (Assembly)	1.2V~3.3 V Option (Assembly)	Mated Board Option (Assembly)
VCC Core	R123 (DI)	R127 (DNI)*	NA
VCCIO0	R124 (DI)	R128 (DNI)	NA
VCCIO1	R125 (DI)	R129 (DNI)	R151 (DNI) for Arduino
VCCIO2	R126 (DI)	R130 (DNI)	NA
VCCIO3	R132 (DI)	R137 (DNI)	R158 (DNI) for Raspberry Pi
VCCIO4	R133 (DI)	R138 (DNI)	NA
VCCIO5	R134 (DI)	R139 (DNI)	NA

***Note:** R127 is applicable only in 2.5 V~3.3 V (U9) range for LCMXO3LF-9400C device.

Warning: Only one option should be enabled for each MachXO3 device power rail.

The ASC device (U7) acquires power from the 3.3 V LDO only. A jumper (JP1) needs to be installed to provide the power and this can also be used as test point to measure current drawn by the ASC.

Table 2.3. ASC Power Connections

ASC Power	ASC Power Pins	ASC Power Isolation (Assembly)
3.3 V VCC	8, 33 of U7	JP1 (DI)

3. JTAG/I²C Programming

The JTAG/I²C programming architecture of the MachXO3-9400 Development Board is shown in Figure 3.1.

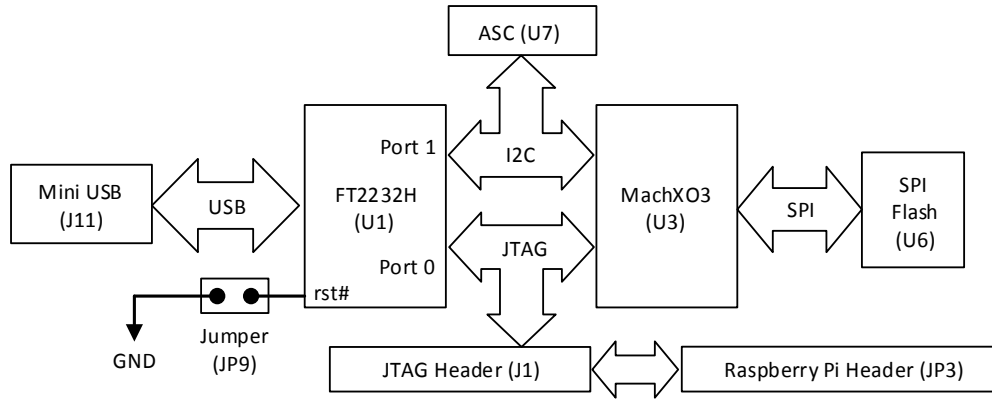

Figure 3.1. JTAG/I²C Programming Architecture

3.1. JTAG Download Interface

The MachXO3-9400 Development Board has a built-in download controller for programming the MachXO3 device. It uses an FT2232H Future Technology Devices International (FTDI) part to convert USB to JTAG. To use the built-in download cable, connect the USB cable from J11 to your PC (with Diamond programming software installed). A mini USB to USB-A cable is included in the MarchXO3-9400 Development Kit. The USB hub on the PC detects the cable of the USB function on Port 0, making the built-in cable available for use with the Diamond programming software. Use PTM Programming for the Access mode as shown in Figure 3.2.

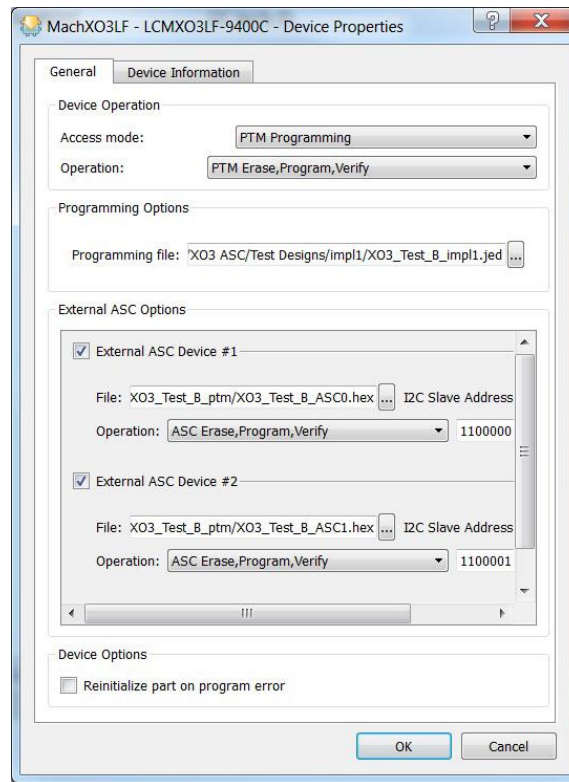

Figure 3.2. PTM Programming Mode

3.2. I²C Download Interface

The USB hub on the PC can also detect the addition of the USB function on Port 1. Select the port FTUSB-1 on the programmer interface and enable the I²C MUX path from FTDI to the I²C bus. This is done by setting the J10 jumper (D57 red LED is lighted). The I²C interface programming can be also used to configure the MachXO3 and ASC.

3.3. Alternate JTAG Download Interface

J1 is an 8-pin standalone JTAG header that is used with an external Lattice download cable (available separately) when the FTDI part is disabled from the JTAG chain after setting JP9. A USB download cable can be attached to the board using J1 to interface with the MachXO3. For details on the connection between the USB download cable and J1, refer to UG48, [Programming Cable User's Guide](#).

J1 can also be used as test point when USB to JTAG is working. Additionally, you can enable the JTAG access path through the Raspberry Pi header (JP3) for customer applications. This is done by connecting the JP3 header to the J1 header through some onboard resistors. The JTAG connections between J1 and JP3 are listed in [Table 3.1](#).

Table 3.1. JTAG Connections

J1 Pin Number	JTAG Signal Name	MachXO3 Ball Location for JTAG	JP3 Pin Number	J1 to JP3 Isolation (Assembly)	Raspberry Pi GPIO
1	VCCIO0	—	—	—	—
2	TDO	E8	10	R90 (DNI)	IO15
3	TDI	E9	11	R93 (DNI)	IO17
4	—	—	—	—	—
5	—	—	—	—	—
6	TMS	C10	12	R91 (DNI)	IO18
7	GND	—	—	—	—
8	TCK	D10	8	R95 (DNI)	IO14

3.4. JTAG to MSPI Pass-through Interface

The download controller can also access the JTAG to MSPI pass-through circuit that allows the slave SPI Flash to be erased, programmed, and read with Diamond Programmer.

3.5. Other JTAG Configuration Pins

The MachXO3-9400 Development Board provides test points for other JTAG configuration pins as shown in [Table 3.2](#).

Table 3.2. Other JTAG Signals

Signal Name	MachXO3 Ball Location	Test Point
JTAGENB	E14	TP6
PROGRAMN	E15	Pin 1 of JP5
INITN	F16	TP7
DONE	E17	TP8

For more information on MachXO3 JTAG/ I²C programming, refer to TN1279, [MachXO3 Programming and Configuration Usage Guide](#).

4. MachXO3 Clock Sources

The MachXO3-9400 Development Board has four options for the MachXO3 clock sources:

- 12 MHz from U1
- 8 MHz from U7
- User defined frequency by installing an oscillator in the Y2 (DNI) footprint
- Off board clock source from J10 (DNI)

The 8 MHz clock from U7 is the default clock source when building a Platform Manager design. Note that JP1 should be installed to power the ASC device.

The 12 MHz clock from the FT2232H FTDI device is another clock source. Its use requires JP11 to be installed to connect the 12 MHz clock signal to the MachXO3 device I/O. JP9 should not be installed to enable U1.

Table 4.1. JTAG Connections

Clock Frequency	Signal Name	MachXO3 Ball Location	Clock Source	Comments
8 MHz	ASC_CLK	L1	U7	JP1 installed, test point TP14
12 MHz	12MHz	B10	U1	JP11 installed, JP9 removed
User defined	OSC_IN	D22	Y2 (DNI)	JP4 removed and OSC_EN signal (MachXO3 ball L20) Logic 1.
User defined	OSC_IN	D22	J10 (DNI)	Y2 not installed, or OSC_EN signal (MachXO3 ball L20) Logic 0, or JP4 installed.

Additional information on using optional clock sources:

- The board provides for an optional clock input for the MachXO3 from either the Oscillator (Y2) or the SMA header (J10) as shown in [Figure 4.1](#). Neither of them are populated.
- Y2 should be installed by the end user and it should be a 2.5 mm x 2.0 mm 4-SMD package. This is compatible with the ASDMB serial of the Ultra Miniature Pure Silicon™ Clock Oscillator from Abracon LLC. JP4 can be used to disable Y2 output by pulling down OSC_EN, which can also be controlled by the L20 pin of MachXO3.
- J10 should be installed by the end user. A Complementary Metal-Oxide Semiconductor (CMOS) compatible clock can then be connected with an SMA cable.

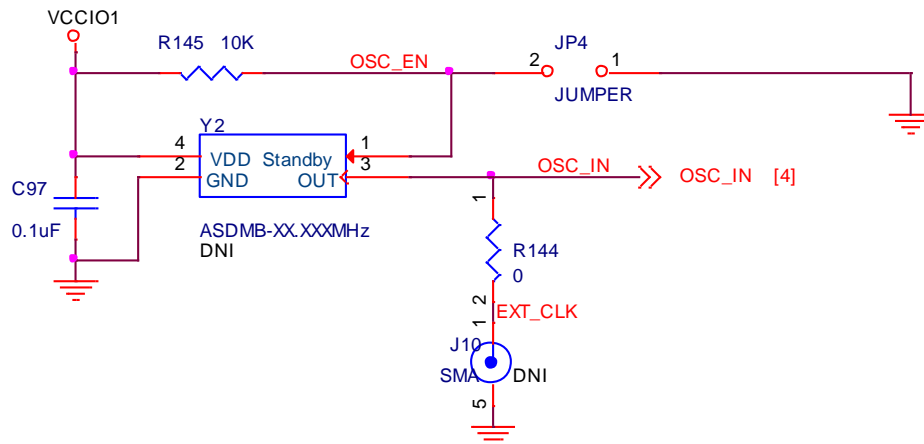

Figure 4.1. Optional Clock Circuit Design

5. Headers and Test Connections

This section describes the MachXO3-9400 Development Board headers and test connections.

5.1. Versa Headers

The board provides two headers – X2 and X3 for expansion purpose.

Table 5.1. Versa X2 Header Pin Connections

X2 Pin Number	Signal Name	MachXO3 Ball Location
1	GND	—
2	NC	—
3	EXPCON_2V5*	—
4	EXPCON_IO29	E12
5	EXPCON_IO30	D14
6	EXPCON_IO31	C15
7	EXPCON_IO32	C17
8	EXPCON_IO33	D15
9	EXPCON_IO34	C18
10	EXPCON_IO35	D16
11	EXPCON_IO36	C19
12	EXPCON_IO37	D17
13	EXPCON_IO38	D18
14	EXPCON_IO39	C20
15	EXPCON_IO40	E16
16	EXPCON_IO41	E13
17	EXPCON_IO42	F13
18	EXPCON_IO43	F15
19	EXPCON_IO44	G15
20	EXPCON_IO45	G12
21	5VIN*	—
22	GND	—
23	EXPCON_2V5*	—
24	GND	—
25	VCCIO0	—
26	GND	—
27	VCCIO0	—
28	GND	—
29	EXPCON_OSC*	—
30	GND	—
31	EXPCON_CLKIN	A10
32	GND	—
33	EXPCON_CLKOUT	A21
34	GND	—
35	EXPCON_3V3**	—

Table 5.1. Versa X2 Header Pin Connections (continued)

X2 Pin Number	Signal Name	MachXO3 Ball Location
36	GND	—
37	EXPCON_3V3**	—
38	GND	—
39	EXPCON_3V3**	—
40	GND	—

Notes:

* Signal is optionally connected to power source through resistor; DNI.

** Signal is optionally connected to power source through resistor; DN.

Table 5.2. Versa X3 Header Pin Connections

X3 Pin Number	Signal Name	MachXO3 Ball Location
1	HPE_RESOUT#	G9
2	GND	—
3	EXPCON_IO0	F8
4	EXPCON_IO1	G8
5	EXPCON_IO2	F9
6	EXPCON_IO3	F7
7	EXPCON_IO4	E7
8	EXPCON_IO5	E6
9	EXPCON_IO6	D5
10	EXPCON_IO7	C3
11	EXPCON_IO8	D6
12	EXPCON_IO9	C4
13	EXPCON_IO10	F10
14	EXPCON_IO11	C5
15	EXPCON_IO12	C6
16	EXPCON_IO13	B12
17	EXPCON_IO14	D7
18	EXPCON_IO15	A12
19	GND	—
20	EXPCON_3V3**	—
21	EXPCON_IO16	D8
22	GND	—
23	EXPCON_IO17	C8
24	GND	—
25	EXPCON_IO18	D9
26	GND	—
27	EXPCON_IO19	E10
28	EXPCON_IO20	C9
29	EXPCON_IO21	G11
30	GND	—
31	EXPCON_IO22	E11

Table 5.2. Versa X3 Header Pin Connections (continued)

X3 Pin Number	Signal Name	MachXO3 Ball Location
32	EXPCON_IO23	D11
33	EXPCON_IO24	F11
34	GND	—
35	EXPCON_IO25	D12
36	EXPCON_IO26	F12
37	EXPCON_IO27	D13
38	CARDSEL#*	—
39	EXPCON_IO28	C14
40	GND	—

Notes:

* Signal is optionally connected to power source through resistor; DNI.

** Signal is optionally connected to power source through resistor; DN.

5.2. Arduino Board GPIO Headers

The board provides four headers – J2, J3, J4 and J5 for Arduino Zero board adaption.

Table 5.3. Arduino J2 Pin Connections

J2 Pin Number	Signal Name	Arduino ZERO Board Signal	MachXO3 Ball Location	Comments
1	AR_IO8	~8	U21	—
2	AR_IO9	~9	U22	—
3	AR_SS_IO10	~10	W20	Optional connection to SS through R67 for SPI access, DNI by default.
4	AR_MOSI_IO11	~11	V18	Optional connection to SISPI through R82 for SPI access, DNI by default.
5	AR_MISO_IO12	~12	G16	Optional connection to SPISO through R77 for SPI access, DNI by default.
6	AR_SCK_IO13	~13	F17	Optional connection to MCLK through R76 for SPI access, DNI by default.
7	GND	GND	—	—
8	AR_AREF	AREF	U17	AR_AREF connection to AREF through R43, DNI by default.
9	AR_SDA	SDA	U19	Optional connection to SDA0 through R44, DNI by default.
10	AR_SCL	SCL	U18	Optional connection to SCL0 through R45, DNI by default.

Table 5.4. Arduino J3 Pin Connections

J3 Pin Number	Signal Name	Arduino ZERO Board Signal	MachXO3 Ball Location	Comments
1	AR_IO0	RX <- 0	G19	—
2	AR_IO1	TX -> 1	G20	—
3	AR_IO2	2	G21	—
4	AR_IO3	~3	H20	—
5	AR_IO4	~4	G18	—
6	AR_IO5	~5	L21	—
7	AR_IO6	~6	W22	—
8	AR_IO7	7	V22	—
9	AR_SDA	SDA	U19	—
10	AR_SCL	SCL	U18	—

Table 5.5. Arduino J4 Pin Connections

J3 Pin Number	Signal Name	Arduino ZERO Board Signal	MachXO3 Ball Location	Comments
1	AR_IO14	ATN	T17	—
2	NC	IOREF	—	—
3	AR_RESET	RESET	U20	Pin U20 should be set high by default. Avoid Arduino ZERO board in Reset status when connected.
4	+3.3V_AR	3.3 V	—	3.3 V power supply from Arduino ZERO board
5	AR_5V	5 V	—	Jump to 5 V main power through JP6
6	GND	GND	—	—
7	GND	GND	—	—
8	+12V	VIN	—	12 V power supply from Arduino ZERO board

Table 5.6. Arduino J5 Pin Connections

J3 Pin Number	Signal Name	Arduino ZERO Board Signal	MachXO3 Ball Location	Comments
1	AR_AD0	A0	P19	Used as GPIO in digital mode
2	AR_AD1	A1	P18	Used as GPIO in digital mode
3	AR_AD2	A2	P17	Used as GPIO in digital mode
4	AR_AD3	A3	P16	Used as GPIO in digital mode
5	AR_AD4	A4	K22	Used as GPIO in digital mode
6	AR_AD5	A5	G17	Used as GPIO in digital mode

Note: If JP6 is installed, 5 V power can be supplied from either the Arduino board or the MachXO3-9400 Development Board. With JP6 removed, both boards need their own 5 V power.

5.3. FX12 Headers (DNI)

The board provides two headers – U4 and U5 to connect to FX12 compatible boards or cables. Each header has eight pairs of Low-Voltage Differential Signaling (LVDS) signals for high speed data receiver.

Table 5.7. FX12 U4 Header Pin Connections

U4 Pin Number	Signal Name	MachXO3 Ball Location
1	CH0_DCK_P	AA10
2	CH0_DCK_N	AB10
3	GND	—
4	CH0_DATA0_P	AA4
5	CH0_DATA0_N	AB4
6	GND	—
7	CH0_DATA2_P	AA5
8	CH0_DATA2_N	AB5
9	GND	—
10	FX_SN*	—
11	FX_SCLK*	—
12	PWR_12V**	—
13	SDA2	AB13
14	SCL2	AA13
15	GND	—
16	CH2_DATA0_P	AA6
17	CH2_DATA0_N	AB6
18	GND	—
19	CH2_DCK_P	AA7
20	CH2_DCK_N	AB7
21	PWR_12V**	—
22	RESETN	AB3
23	PWR_5-0V*	—
24	CH0_DATA1_P	AA2
25	CH0_DATA1_N	AB2
26	PWR_3-3V*	—
27	CH0_DATA3_P	AA8
28	CH0_DATA3_N	AB8
29	PWR_1-8V*	—
30	FX_MOSI*	—
31	FX_MISO*	—
32	PWR_1-8V*	—
33	GND	—
34	GND	—
35	PWR_3-3V*	—
36	CH2_DATA1_P	AA9
37	CH2_DATA1_N	AB9

Table 5.7. FX12 U4 Header Pin Connections (continued)

U4 Pin Number		Signal Name	MachXO3 Ball Location
38		PWR_5-0V*	-
39		SDA1	AA11
40		SCL1	AB11

Notes:

* Signal is optionally connected to power source through resistor; DNI.

** 12 V power needs external supply from pin 8 of J4.

Table 5.8. FX12 U5 Header Pin Connections

U5 Pin Number	Signal Name	MachXO3 Ball Location
1	CH1_DCK_P	AB12
2	CH1_DCK_N	AA12
3	GND	—
4	CH1_DATA0_P	AB16
5	CH1_DATA0_N	AA16
6	GND	-
7	CH1_DATA2_P	AB17
8	CH1_DATA2_N	AA17
9	GND	—
10	FX_SN*	—
11	FX_SCLK*	—
12	PWR_12V**	—
13	SDA2	AB13
14	SCL2	AA13
15	GND	— -
16	CH3_DATA0_P	AB18
17	CH3_DATA0_N	AA18
18	GND	— -
19	CH3_DCK_P	AB19
20	CH3_DCK_N	AA19
21	PWR_12V**	— -
22	RESETN	AB3
23	PWR_5-0V*	— -
24	CH1_DATA1_P	AB14
25	CH1_DATA1_N	AA14
26	PWR_3-3V*	— -
27	CH1_DATA3_P	AB15
28	CH1_DATA3_N	AA15
29	PWR_1-8V	—
30	FX_MOSI*	—
31	FX_MISO*	—
32	PWR_1-8V*	—
33	GND	—

Table 5.8. FX12 U5 Header Pin Connections (continued)

U5 Pin Number	Signal Name	MachXO3 Ball Location
34	GND	- -
35	PWR_3-3V*	- -
36	CH3_DATA1_P	AB20
37	CH3_DATA1_N	AA20
38	PWR_5-0V*	- -
39	SDA1	AA11
40	SCL1	AB11

Notes:

* Signal is optionally connected to power source through resistor; DNI.

** 12 V power needs external supply from pin 8 of J4.

5.4. Aardvark Header (DNI)

The Aardvark I²C /SPI Host Adapter is a fast and powerful I²C bus and SPI bus host adapter through USB. It allows a developer to interface a Windows, Linux, or Mac OS X PC through USB to a downstream embedded system environment and transfer serial messages using the I²C and SPI protocols.

The MachXO3-9400 Development Board provides an Aardvark compatible header for customer applications. The I²C bus is capable of connecting to a global I²C bus on the board if JP10 is NOT set.

Table 5.9. Aardvark JP2 Header Pin Connections

JP2 Pin Number	Signal Name	MachXO3 Ball Location
1	JP2_SCL	To I ² C analog switch U10
2	—	GND
3	JP2_SDA	To I ² C analog switch U11
4	+5V_I2C	To VBUS_5V through R78, DNI
5	SPISO	To MachXO3 U9
6	+5V_SPI	To VBUS_5V through R79, DNI
7	MCLK	To MachXO3 T9
8	SISPI	To MachXO3 AA21
9	SS	Multiple options, as shown in Figure 5.1 .
10	—	—

Caution: VCCIO2 should be 3.3 V when connected to Aardvark I²C/SPI Host Adapter.

Pin 9 of the Aardvark header is an SS signal, which is optionally connected to multiple devices or connectors. By default, it can access Slave SPI in the MachXO3 device as the Master SPI through R160. It can access FX12 header, Raspberry Pi header and on-board SPI Flash by enabling R161. It can also access the Arduino header by enabling R67.

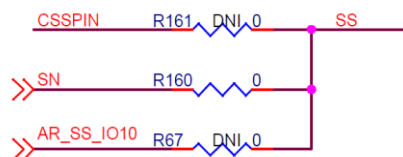

Figure 5.1. Aardvark SS Pin Connections

5.5. Raspberry Pi Board GPIO Header

The MachXO3-9400 Development Board provides a 40-pin receptacle which is compatible with the GPIO header of Raspberry Pi 2/3 serial models.

Table 5.10. Raspberry Pi JP3 Header Pin Connections

JP3 Pin Number	Signal Name	MachXO3 Ball Location
1	3.3V_RASP*	—
2	RASP_5V**	—
3	RASP_IO02	T6
4	RASP_5V**	—
5	RASP_IO03	V1
6	GND	—
7	RASP_IO04	U2
8	RASP_IO14	P4
9	GND	—
10	RASP_IO15	N5
11	RASP_IO17	N6
12	RASP_IO18	N7
13	RASP_IO27	P5
14	GND	—
15	RASP_IO22	P6
16	RASP_IO23	R3
17	3.3V_RASP*	—
18	RASP_IO24	R4
19	RASP_IO10	R6
20	GND	—
21	RASP_IO09	R7
22	RASP_IO25	R5
23	RASP_IO11	T3
24	RASP_IO08	T4
25	GND	—
26	RASP_IO07	T5
27	RASP_ID_SD	V5
28	RASP_ID_SC	T7
29	RASP_IO05	U3
30	GND	—
31	RASP_IO06	U4
32	RASP_IO12	V4
33	RASP_IO13	U5
34	GND	—
35	RASP_IO19	W3
36	RASP_IO16	W4
37	RASP_IO26	P7

Table 5.10. Raspberry Pi JP3 Header Pin Connections *(continued)*

JP3 Pin Number	Signal Name	MachXO3 Ball Location
38	RASP_IO20	Y2
39	GND	—
40	RASP_IO21	Y3

Notes:

* 3.3 V power is supplied from Raspberry Pi board.

** 5 V power can come from either the Raspberry Pi board or the MachXO3-9400 development board when jumper JP7 is installed. When jumper JP7 is not installed, both boards need their own 5 V power.

6. I²C and SPI Buses

This section describes the MachXO3-9400 Development Board I²C and SPI topology.

6.1. I²C Topology

The MachXO3-9400 Development Board has a flexible I²C bus to support all optional connectors and devices on the board. The global I²C bus has the signal names SDA0 and SCL0 and they are routed close to the devices and headers as shown in Figure 6.1.

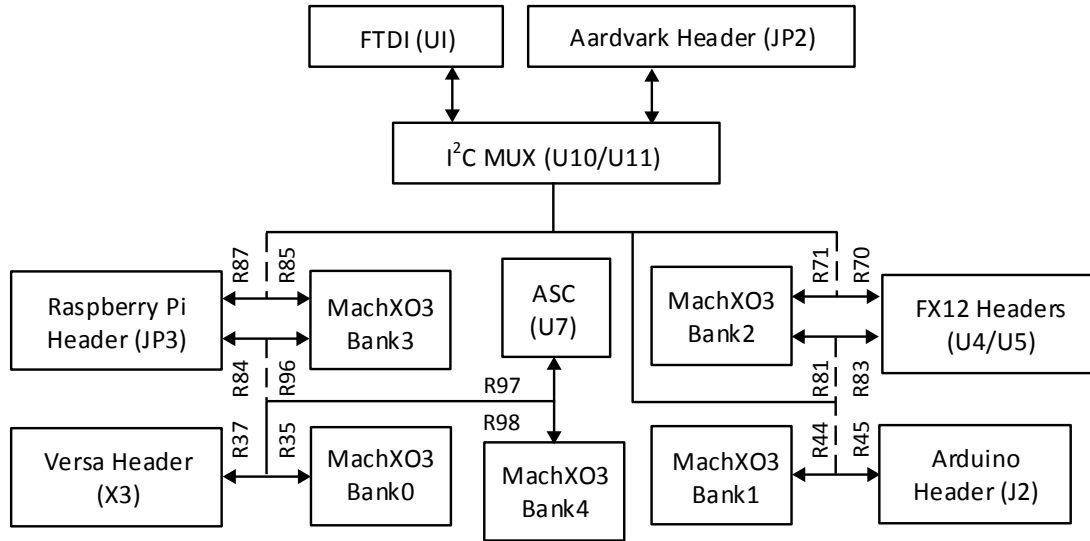

Figure 6.1. I²C Topology

The board provides two options for accessing the global I²C bus from external cables. One is from the mini USB cable (J11) through FTDI (U1) and the other is from the Aardvark header (JP2) for an Aardvark cable. Two analog MUXes, as shown in Figure 6.2, are used to select between the USB and Aardvark cables, both MUXes are controlled by the signal USB_I2C_EN.

Table 6.1. I²C MUX Function

Global I ² C Controller	USB_I2C_EN Logic Level	FSA4157 MUX Function	SCL0 Test Point	SDA0 Test Point
Aardvark Header (JP2)	0 (JP10 removed)	JP2_SCL <> SCL0 JP2_SDA <> SDA0	Pin1 of JP2	Pin3 of JP2
USB FTDI (U1)	1 (JP10 installed)	FTDI_SCL <> SCL0 FTDI_SDA <> SDA0	TP1	TP2

When the jumper JP10 is removed, the USB_I2C_EN signal is low and the Aardvark header JP2 is connected to the global I²C bus. When the jumper JP10 is installed, the USB_I2C_EN signal is high and the USB connector J11 is connected to the global I²C bus through the FTDI device.

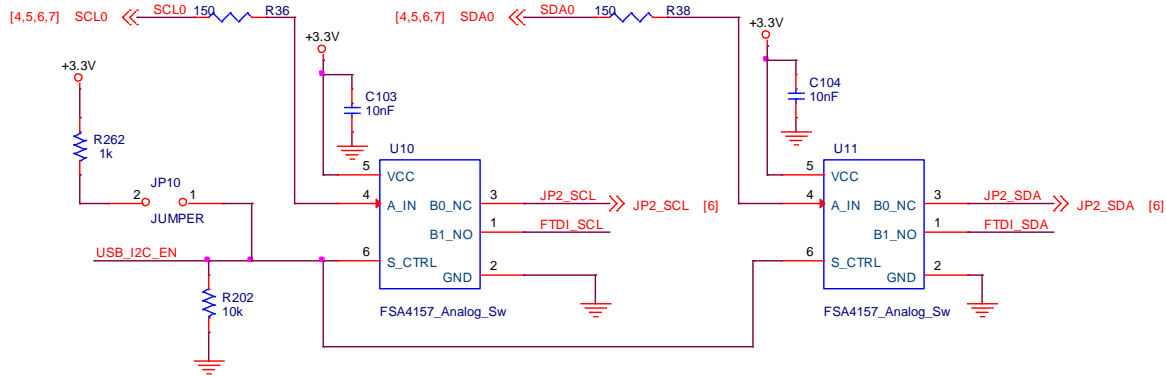

Figure 6.2. I²C MUX Circuits

To support a wide variety of I²C applications, each header or device is connected to a dedicated MachXO3 GPIO bank with a direct local I²C bus. Each local I²C bus can optionally connect to the global I²C bus through resistors. The local I²C connections are summarized in Table 6.2.

Table 6.2. I²C Global Bus Connections

MachXO3 Bank	Component (Reference)	Header Pin	MachXO3 Ball	Local Signal Name (Global I ² C Signal)	Resistor
0	Versa header (X3)	18	A12	EXPCON_IO15 (SDA0)	R37 (DI)*
		16	B12	EXPCON_IO13 (SCL0)	R35 (DI)*
1	Arduino header (J2)	9	U19	AR_SDA (SDA0)	R44 (DNI)
		10	U18	AR_SCL (SCL0)	R45 (DNI)
2	FX12 headers (U4/U5)	39	AA11	SDA1 (SDA0)	R81 (DNI)
		40	AB11	SCL1 (SCL0)	R83 (DNI)
	FX12 headers (U4/U5)	13	AB13	SDA2 (SDA0)	R71 (DNI)
		14	AA13	SCL2 (SCL0)	R70 (DNI)
3	Raspberry Pi header (JP3)	3	T6	RASP_IO02 (SDA0)	R84 (DNI)
		5	V1	RASP_IO03 (SCL0)	R96 (DNI)
		27	V5	RASP_ID_SD (SDA0)	R87 (DNI)
		28	T7	RASP_ID_SC (SCL0)	R85 (DNI)
4	ASC device (U7)	14	K2	I2C_SDA0 (SDA0)	R97 (DI)*
		15	K1	I2C_SCL0 (SDA0)	R98 (DI)*

***Note:** The resistor needs to be installed to support programming of the ASC device. Balls K1 and K2 need to be programmed as inputs to support programming of the ASC device. Versa header X3 pins 16 and 18 need to be high-z to support programming of the ASC device. Balls B12 and A12 should be used in Platform Manager designs. Balls K1 and K2 provide a connection for a user instantiated I²C port as part of a separate system to communicate with the ASC device.

6.2. SPI Topology

6.2.1. SPI Configuration

One of the major functions of SPI connections on the board is to support MachXO3 configuration from SPI ports. The MachXO3-9400 Development Board can support both Master SPI (MSPI) and Slave SPI (SSPI) modes for MachXO3 configuration.

Table 6.3. MachXO3 SPI Connections

Signal Name	MachXO3 Ball Location	MSPI Mode Direction	SSPI Mode Direction
MCLK	T9	Output	Input
SN	AB21	Input	Input
SISPI	AA21	Output	Input
SPISO	U9	Input	Output
CSSPIN	AA3	Output	Not used

The MachXO3 can be configured from different ports on the board as listed in [Table 6.4](#). By default, the MachXO3 can boot up from SPI Flash with Master SPI mode.

Table 6.4. MachXO3 SPI Configuration Options

Master SPI Device (Reference)	Master CS (Pin Number of Reference Part)	Slave SPI Device (Reference)	Slave CS (Pin Number of Reference Part)
MachXO3 (U3)	CSSPIN (AA3)	SPI Flash (U6)	CS# (1)
MachXO3 (U3)	CSSPIN (AA3)	FX12 (U4, U5)	FX_SN (10)
Aardvark (JP2)	SS (9)	MachXO3 (U3)	SN (AB21)
Arduino (J2)	AR_SS_IO10 (3)	MachXO3 (U3)	SN (AB21)
Raspberry Pi (JP3)	Rasp_IO08 (24)	MachXO3 (U3)	SN (AB21)

Note: Make sure that only one Master SPI and one Slave SPI are working at the same time.

For detailed information on Master SPI and Slave SPI mode configuration, refer to TN1279, [MachXO3 Programming and Configuration Usage Guide](#).

6.2.2. SPI Flash Access

Onboard SPI Flash memory can be used to store the MachXO3 configuration data in either External or Dual Boot mode. It can also store customer data in certain applications. The MachXO3 device includes the JTAG to MSPI pass-through circuit that allows the slave SPI Flash to be erased, programmed, and read with Diamond Programmer. For detailed information on JTAG to MSPI pass-through for slave SPI Flash access, refer to TN1279, [MachXO3 Programming and Configuration Usage Guide](#).

7. LEDs and Switches

This section describes the MachXO3-9400 Development Board LEDs and switches that can be used in demo and customer designs.

7.1. Four-Position DIP Switch

Four MachXO3 pins are connected to the four switches of SW1, as shown in the circuit design in [Figure 7.1](#). The CTS side actuated DIP switches are connected to logic level 0 when in the ON position as shown in [Figure 7.2](#).

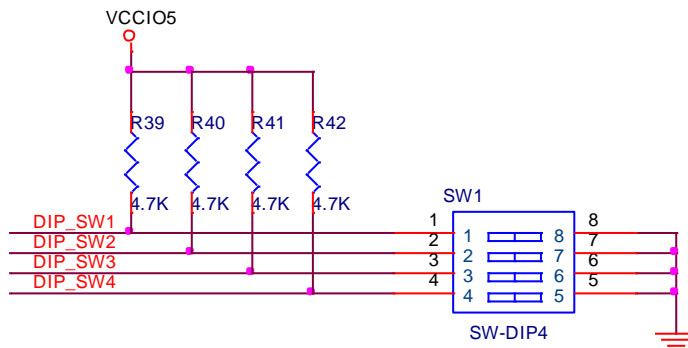

Figure 7.1. Four-Position DIP Switch Circuits



Figure 7.2. Four-Position DIP Switch Photograph

One side of each switch is connected to GPIOs within the VCCIO5 bank and pulled up through 4.7 kΩ resistors. The other side is grounded. The designated pins are connected as shown in [Table 7.1](#).

Table 7.1. Four-Position DIP Switch Signals

Signal Name	MachXO3 Ball Location	SW1 DIP Switch Position	4.7K Pull up Resistor	Logic Level at ON Position
DIP_SW1	H5	1	R39	0
DIP_SW2	J5	2	R40	0
DIP_SW3	J4	3	R41	0
DIP_SW4	J3	4	R42	0

7.2. General Purpose Push Buttons

The MachXO3-9400 Development Board provides four push button switches – SW2, SW3, SW4 and SW5 for demos and user applications. Pressing these buttons drives a logic level “0” to the corresponding I/O pins.

Table 7.2. Push Button Switch Signals

Signal Name	MachXO3 Ball Location	Push Button Reference	Logic Level at Button Pressed
PB1	D3	SW2	0
PB2	D4	SW3	0
PB3	F6	SW4	0
PB4	G7	SW5	0

SW2, SW3 and SW4 are designed for general purpose applications and SW5 is designed with additional jumper JP5 as shown in Figure 7.3. SW5 can be used as PROGRAMN push button when JP5 is set to trigger the configuration process without power cycle. For detailed information on PROGRAMN, refer to TN1279, [MachXO3 Programming and Configuration Usage Guide](#).

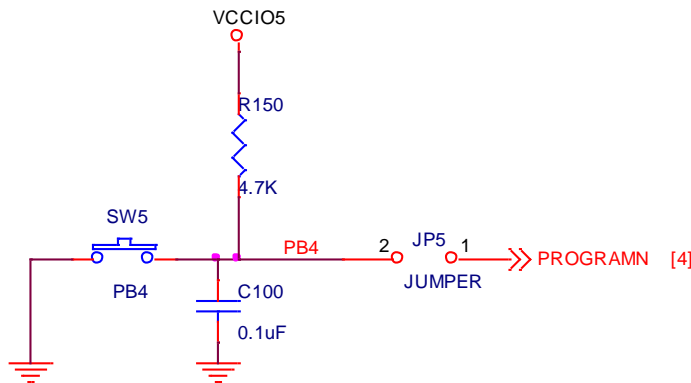

Figure 7.3. Push Button SW5 Circuit Design

7.3. General Purpose LEDs

The MachXO3-9400 Development Board provides eight red LEDs that are connected to IOs within Bank 5. The LEDs are lighted when the output is driven LOW. Table 7.3 lists the red LEDs and their associated pins.

Table 7.3. LED Signals

Red LEDs	Signal Name	MachXO3 Ball Location	Logic Level to Light
D1	XLED0	D1	0
D2	XLED1	E2	0
D3	XLED2	E3	0
D4	XLED3	F4	0
D5	XLED4	E1	0
D6	XLED5	F1	0
D7	XLED6	G3	0
D8	XLED7	G4	0

Caution: The MachXO3-9400 Development Board contains ESD-sensitive components. ESD safe practices should be followed while handling and using the development board.

Note: The LEDs are not lined up in sequence, as shown in [Figure 7.4](#).

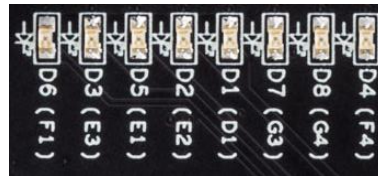

Figure 7.4. Board LEDs

7.4. LVDS Outputs Pins

The MachXO3-9400 Development Board provides nine pairs of unused LVDS outputs pins that are connected to test points for possible customer applications. The LVDS test points are detailed in [Table 7.4](#).

Table 7.4. LVDS Test Points

Signal Name	MachXO3 Ball Location	Test Point	Comments
LVDS_OUT0_P	B1	TP63	LVDS output pair 0
LVDS_OUT0_N	A2	TP64	
LVDS_OUT1_P	B2	TP65	LVDS output pair 1
LVDS_OUT1_N	A3	TP66	
LVDS_OUT2_P	B3	TP67	LVDS output pair 2
LVDS_OUT2_N	A4	TP68	
LVDS_OUT3_P	B4	TP69	LVDS output pair 3
LVDS_OUT3_N	A5	TP70	
LVDS_OUT4_P	B5	TP71	LVDS output pair 4
LVDS_OUT4_N	A6	TP72	
LVDS_OUT5_P	B6	TP73	LVDS output pair 5
LVDS_OUT5_N	A7	TP74	
LVDS_OUT6_P	B8	TP75	LVDS output pair 6
LVDS_OUT6_N	A8	TP76	
LVDS_OUT7_P	B9	TP77	LVDS output pair 7
LVDS_OUT7_N	A9	TP78	
LVDS_OUT8_P	B11	TP79	LVDS output pair 8
LVDS_OUT8_N	A11	TP80	

7.5. General Purpose DDR Outputs

Graphics Double Data Rate (GDDR) signals are wired to the test pads for signal validation.

Table 7.5. GDDR Test Points

Signal Name	MachXO3 Ball Location	Test Point
GDDR_DQ0	R22	TP93
GDDR_DQ1	R21	TP94
GDDR_DQ2	T22	TP95
GDDR_DQ3	T21	TP96
GDDR_DQ4	Y22	TP97
GDDR_DQ5	W21	TP98
GDDR_DQ6	AA22	TP99
GDDR_DQ7	Y21	TP100
GDDR_DQS	N22	TP101
GDDR_DQSN	P21	TP102

8. ASC Connections

8.1. ASC Interface

The MachXO3-9400 Development Board provides the dedicated ASC Interface (ASC-I/F) between the onboard ASC device and the MachXO3 Bank 4. The Platform Manager design in the MachXO3 monitors signal status and controls output behavior of the ASC through the ASC-I/F. The ASC I²C interface is used by the FPGA or an external microcontroller for ASC background programming, interface configuration, and additional data transfer such as parameter measurement or I/O status control.

Table 8.1. ASC to MachXO3 Connections

ASC Connections	MachXO3 Ball Location	ASC Pins	Description	ASC Breakout Test Point
I2C_SDA0	A12 (K2)	14	I ² C data programming (user control)	TP2
I2C_SCL0	B12 (K1)	15	I ² C clock programming (user control)	TP1
ASC_CLK	L1	7	8 MHz clock output from ASC	TP14
ASC_RESEtb	L3	43	ASC device reset (Active Low)	TP13
ASC_WRCLK	M1	6	ASC-I/F clock signal to ASC	TP12
ASC_RDAT	N1	5	ASC-I/F data signal from ASC	TP11
ASC_WDAT	P1	4	ASC-I/F data signal to ASC	TP10
I2C_WRITE_PROTECT	N2	44	I ² C Configuration Write Control signal when WP[1:0] = 10 in ASC WRITEPROTECT_USERTAG Register, pull high to enable overwriting by I ² C instructions.	Share with TP44 for ASC_LED1 if R99 is DI

8.2. ASC Voltage Monitor

ASC Voltage Monitors (VMONs) are connected to various power sources on the board as listed in [Table 8.2](#).

Table 8.2. ASC VMON Connections

Power Name	ASC Signal Name	ASC Pin Number	ASC Breakout Test Point
+1.2V**	ASC_VMON1	26	TP15
GND*	ASC_GS_VMON1	25	TP16
VCC1_8FT**	ASC_VMON2	28	TP17
GND*	ASC_GS_VMON2	27	TP19
+3.3V_RASP**	ASC_VMON3	30	TP18
GND*	ASC_GS_VMON3	29	TP20
+3.3V_AR**	ASC_VMON4	32	TP21
GND*	ASC_GS_VMON4	31	TP22
VBUS_5V**	ASC_VMON5	34	TP23
-	ASC_VMON6	35	TP24
POT***	ASC_VMON7	36	TP25
-	ASC_VMON8	37	TP26
+3.3V_ASC**	ASC_VMON9	38	TP27

Notes:

* Connection to GND is through 100 Ω (R109 – R112) so that the test point can overdrive.

** Connection to the supply is through 270 Ω (R1104 – R108, R182) so that the test point can overdrive.

*** Connection to POT is through 1 kΩ (R277) so that the test point can overdrive.

A 10 kΩ POT is used to provide voltage variation from 0 V - 3.3 V to ASC VMON7 as shown in [Figure 8.1](#).

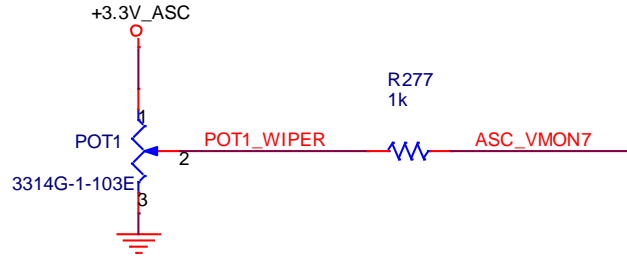

Figure 8.1. POT Circuit Design for VMON7

Rotate the POT clockwise to decrease the voltage as shown in Figure 8.2 and to increase the voltage to VMON7, rotate the POT counter-clockwise.

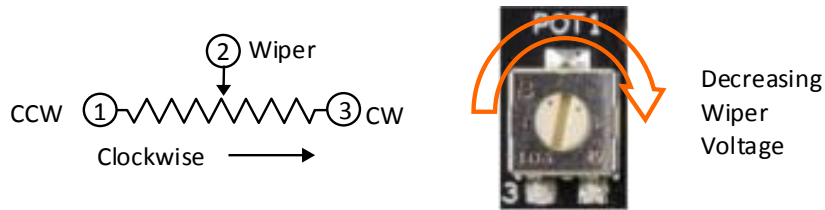

Figure 8.2. POT Wiper Description

8.3. ASC Current Monitor

One of the ASC Current Monitors (IMONs) is connected to monitor the MachXO3 core current using resistor R181 as a shunt. The IMON uses the differential voltage across R181 to monitor the current. The ASC has two IMONs: one is used for lower voltage (-0.3 V to 5.9 V) current monitoring (pins 19 and 20) and the other HIMON (pins 17 and 18) is used for higher voltage (4.5 V to 13.2 V) current monitoring. Pin 18 is a shared input pin used for both HIMON and HVMON (which is VMON10.)

Table 8.3. ASC IMON Connections

Power Name	ASC Signal Name	ASC Pin Number	ASC Breakout Test Point	Comments
VCC_CORE	ASC_IMONP	19	TP30	R181 (0.020 Ω) is placed between P/N node for current measurement
	ASC_IMONN	20	TP31	
User Connected	ASC_HIMONP	17	TP28	HV IMON positive input
	ASC_HVMON	18	TP29	Dual Function: HV IMON negative input and VMON10 input

The VCC_CORE current measurement is designed according to Figure 8.3.

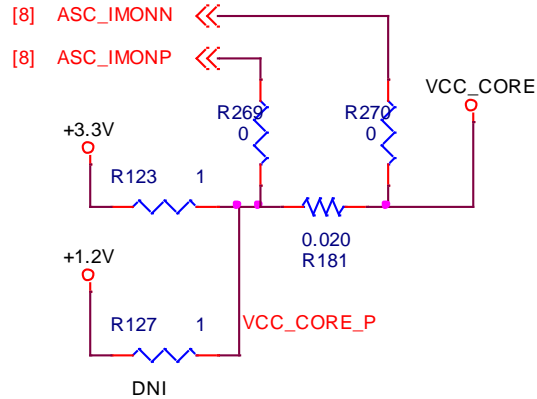

Figure 8.3. VCC Core Current Monitoring Circuit

8.4. ASC Temperature Monitor

The ASC has two external Temperature Monitors (TMONs) which both are connected to on board temperature sensors as listed in Table 8.4. One TMON is connected to a PNP transistor as shown in Figure 8.4 and the other TMON is connected to an NPN transistor as shown in Figure 8.5. Note that the noise suppression capacitors (C33 and C34) are shown on the schematic as close to the transistors. However, they are physically close to the L-ASC10 (U7).

Table 8.4. ASC TMON Connections

Temperature Sensor (Reference)	ASC Signal Name	ASC Pin Number	ASC Breakout Test Point	Comments
Temperature Sensor 1 (Q1)	TEMP_SENSE1P	21	TP32	PNP Type
	TEMP_SENSE1N	22	TP33	
Temperature Sensor 2 (Q2)	TEMP_SENSE2P	23	TP34	NPN Type
	TEMP_SENSE2N	24	TP35	



Figure 8.4. PNP Temperature Sensor Circuit



Figure 8.5. NPN Temperature Sensor Circuit

8.5. ASC LEDs

As shown in [Figure 8.6](#), there are nine red LEDs to support ASC applications. They are connected to the ASC GPIOs as listed in [Table 8.5](#). The LEDs illuminate when the GPIO is driven low.



Figure 8.6. ASC LEDs

Table 8.5. GPIO LED Connections

Signal Name	ASC Pin Number	LED	Breakout Test Point	Logic Level to Light
ASC_LED1	44	D9	TP44	0
ASC_LED2	45	D10	TP45	0
ASC_LED3	46	D11	TP46	0
ASC_LED4	47	D12	TP47	0
ASC_LED5	48	D13	TP48	0
ASC_LED6	1	D14	TP49	0
ASC_LED8	11	D15	TP50	0
ASC_LED9	12	D16	TP51	0
ASC_LED10	13	D17	TP52	0

Caution: The MachXO3-9400 Development Board contains ESD-sensitive components. ESD safe practices should be followed while handling and using the development board.

Note: The LEDs are lined up in sequence, as shown in [Figure 8.6](#).

8.6. ASC HVOUT and Trim Pins

The ASC has four high-voltage charge-pump outputs (HVOUTs) and four Trim-DAC outputs (TRIMs) which are brought out to test pins for user convenience as listed in [Table 8.6](#). The HVOUTs are designed to drive the gates of MOSFETs to enable circuits and loads. The TRIMs are designed to drive the trim inputs of DC-DC converters to adjust the output voltage.

Table 8.6. ASC HVOUT and Trim Connections

Signal Name	ASC Pin Number	Breakout Test Point
ASC_HVOUT1	2	TP40
ASC_HVOUT2	3	TP41
ASC_HVOUT3	9	TP42
ASC_HVOUT4	10	TP43
ASC_TRIM1	39	TP36
ASC_TRIM2	40	TP37
ASC_TRIM3	41	TP38
ASC_TRIM4	42	TP39

9. Software Requirements

The following software are required to develop designs for the MachXO3-9400 Development Board:

- Diamond 3.9 (or higher)
- Diamond Programmer 3.9 (or higher)
- LatticeMico System Development Tools

10. Storage and Handling

Static electricity can shorten the life span of electronic components. Observe these tips to prevent damage that can occur from electrostatic discharge:

- Use antistatic precautions such as operating on an antistatic mat and wearing an antistatic wristband.
- Store the development board in the provided packaging.
- Touch a metal USB housing to equalize voltage potential between you and the board.

11. Ordering Information

Table 11.1 Ordering Information

Description	Ordering Part Number	China RoHS Environment-Friendly Use Period (EFUP)
MachXO3-9400 Development Board	LCMXO3LF-9400C-B-EVN	

References

Lattice Semiconductor Documents

Related documents available from your Lattice Semiconductor sales representative are listed on the table below.

Document	Title
DS1042	L-ASC10 Data Sheet
DS1047	MachXO3 Family Data Sheet
FPGA-UG-02021	<i>LCMXO3LF-9400C Simple Hardware Management Demo User Guide</i>
FPGA-UG-02022	<i>LCMXO3LF-9400C Hitless I/O Demo User Guide</i>
FPGA-UG-02023	<i>LCMXO3LF-9400C SED/SEC Demo User Guide</i>
QS043	<i>MachXO3-9400 Development Board Quick Start Guide</i>
TN1279	MachXO3 Programming and Configuration Usage Guide
UG48	Programming Cable User's Guide

Technical Support Assistance

Submit a technical support case through www.latticesemi.com/techsupport.

Appendix A. MachXO3-9400 Development Board Schematics

	5	4	3	2	
D	<h1>MachXO3-9400-Dev-Brd</h1> <h2>Rev - B</h2>				
C	<p>01 - Title Page</p> <p>02 - Block Diagram</p> <p>03 - USB to JTAG I/F</p> <p>04 - Versa Headers (BANK0)</p> <p>05 - Arduino Headers (BANK1)</p> <p>06 - CrossLink Headers (BANK2)</p> <p>07 - Raspberry Pi Header & Others (BANK3/4/5)</p> <p>08 - Analog Sense and Control</p> <p>09 - Power Decoupling and LEDs</p> <p>10 - Power Regulators</p>				
B					
A					
	5	4	3	2	



Lattice Semiconductor Application
<http://www.latticesemi.com>
 Phone (503) 268-8001 -or- (800) LAT

Title		Title page
Size	Project	
A		MachXO3-9400-Dev-Brd
Date:	Monday, May 22, 2017	
	2	Shee

Figure A.1. Title Page

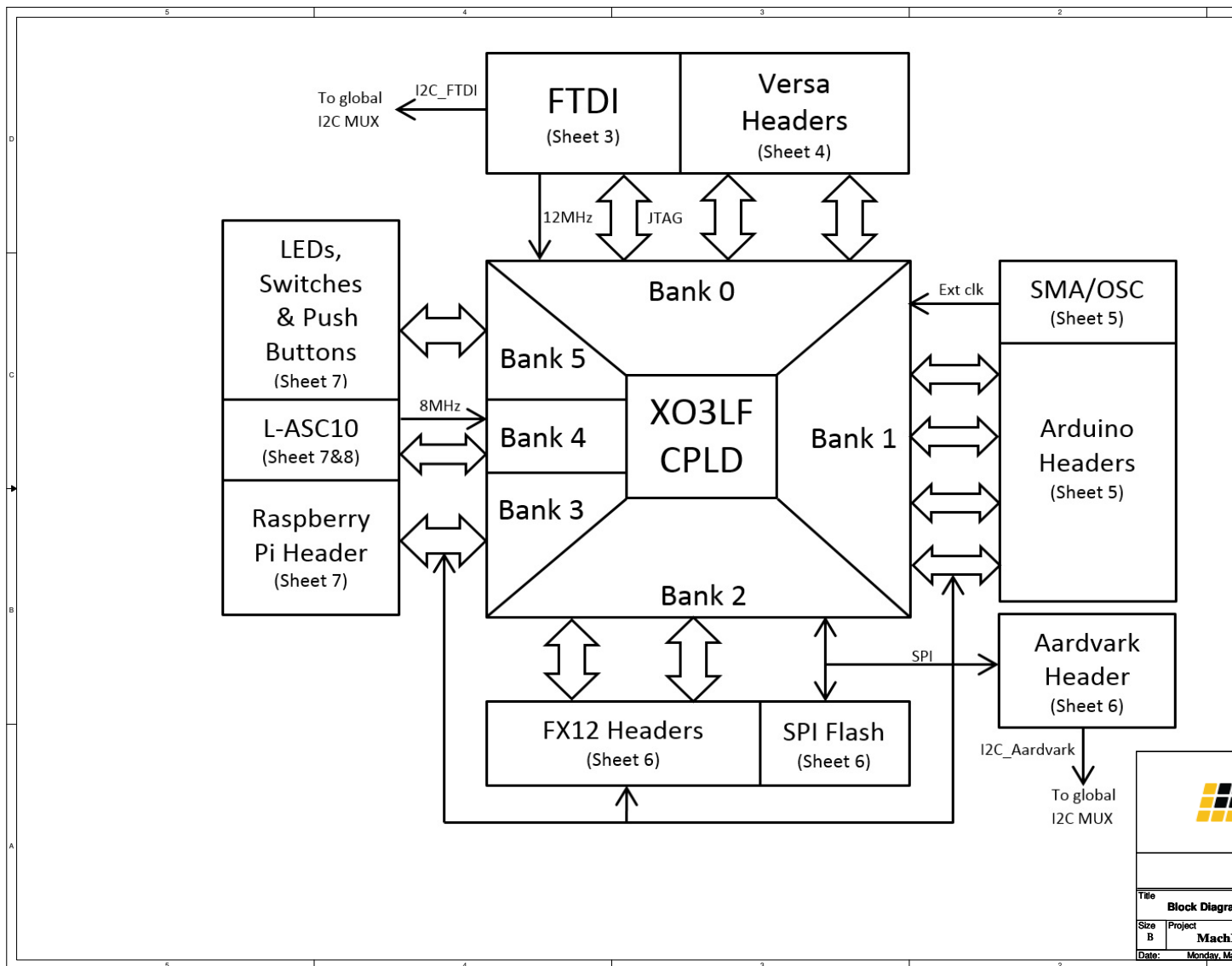

Figure A.2. Block Diagram

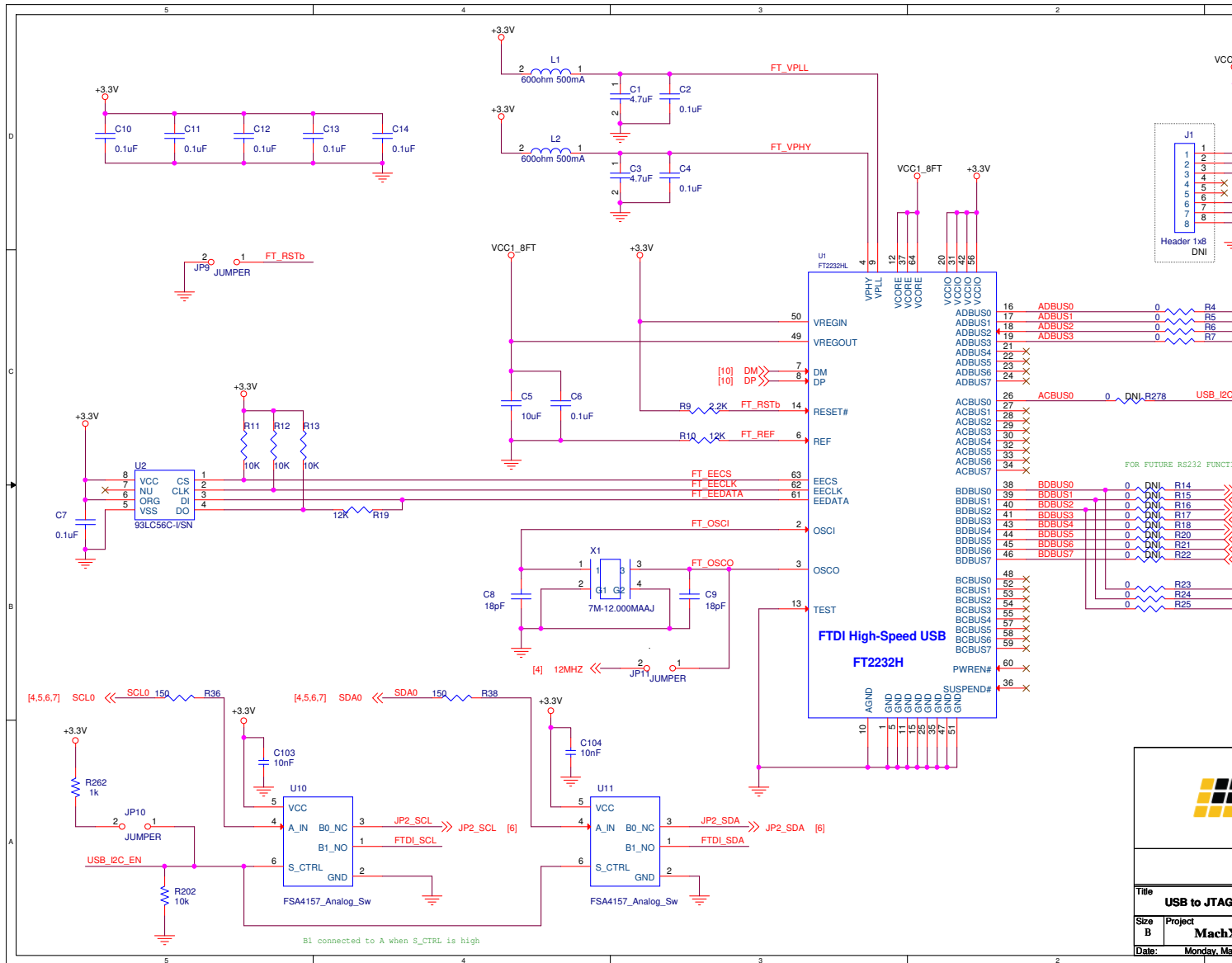

Figure A.3. USB to JTAG I/F

MachXO3-9400 Development Board
Evaluation Board User Guide

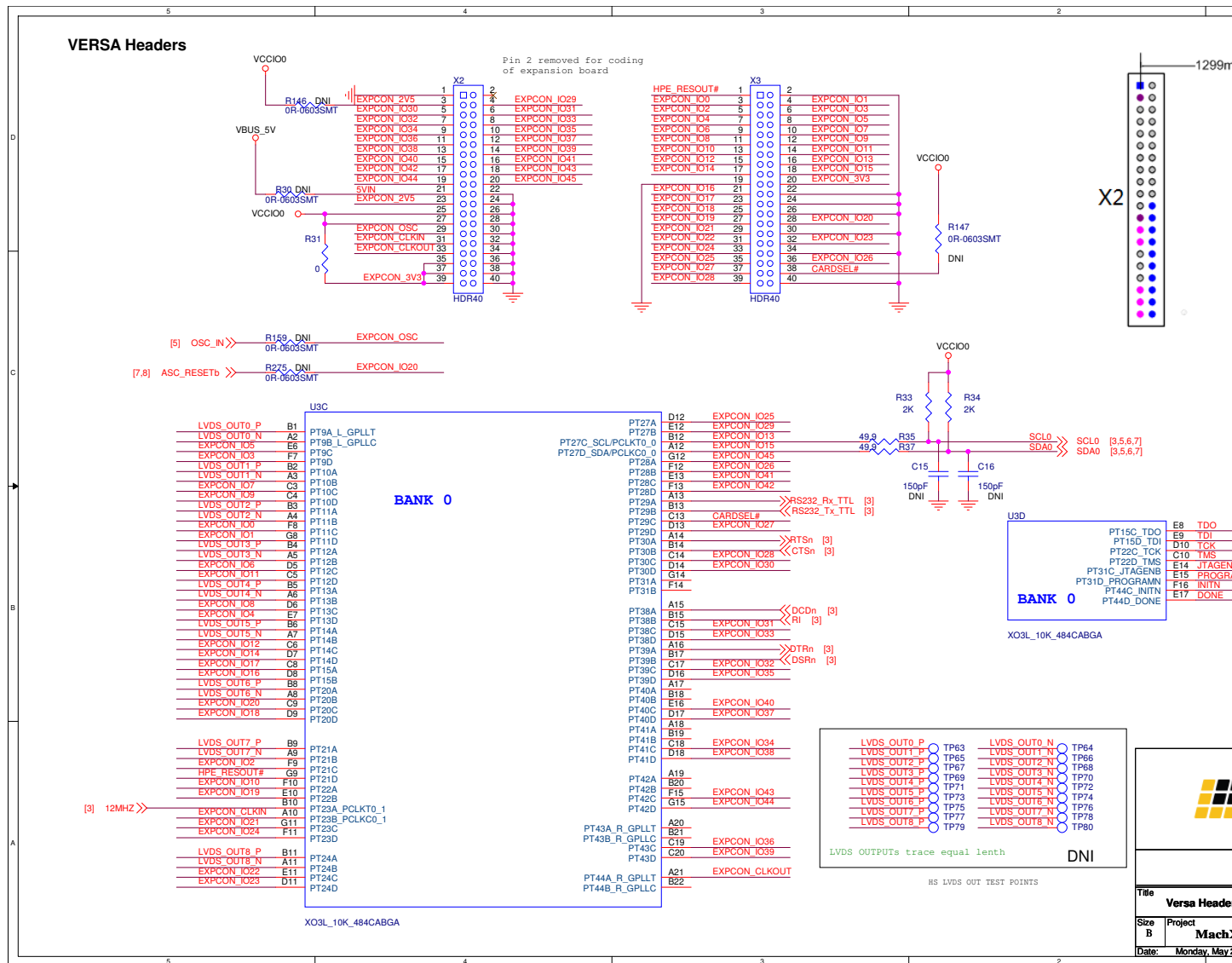

Figure A.4. VERSA Headers (BANK0)

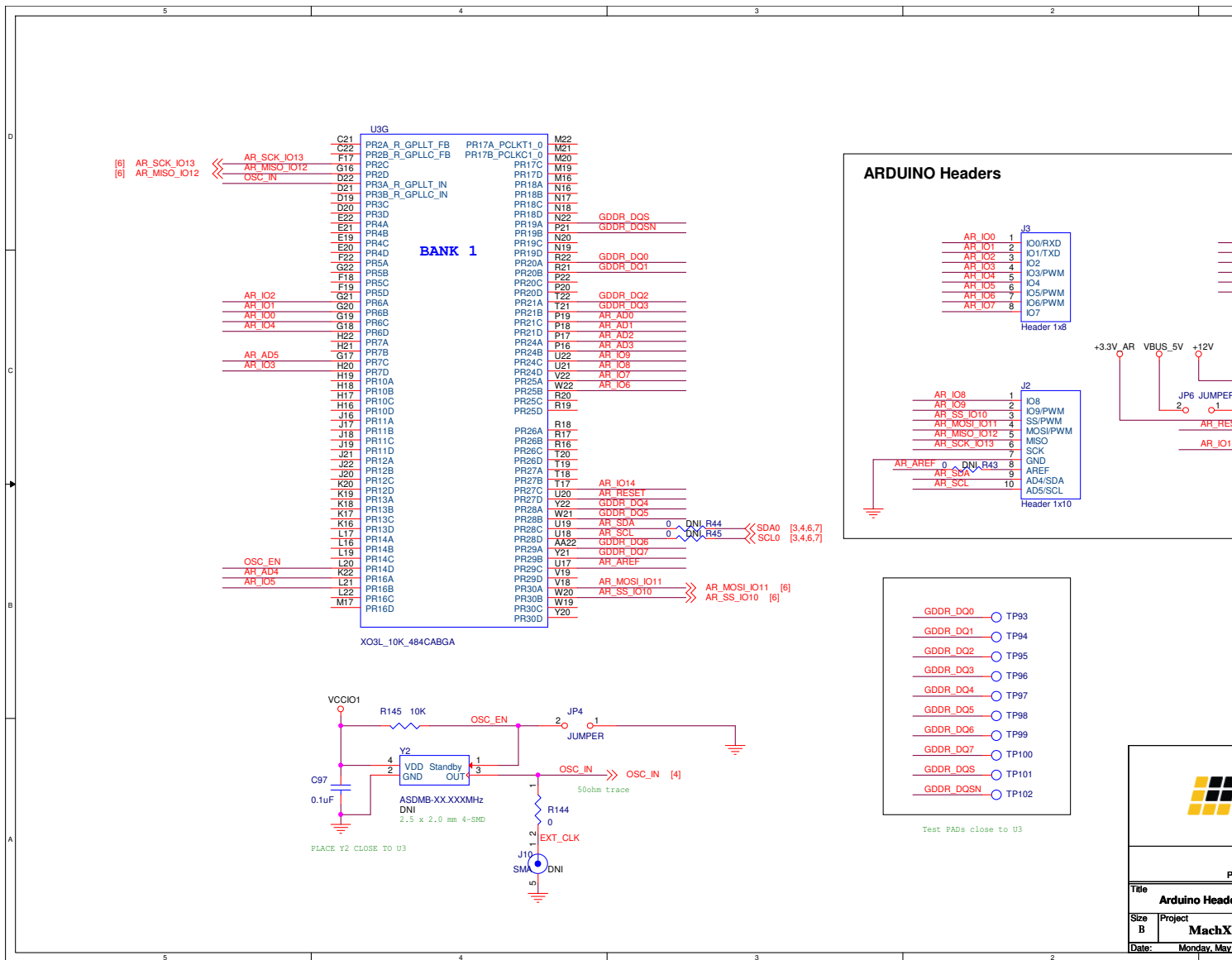

Figure A.5. Arduino Headers (BANK1)

MachXO3-9400 Development Board Evaluation Board User Guide

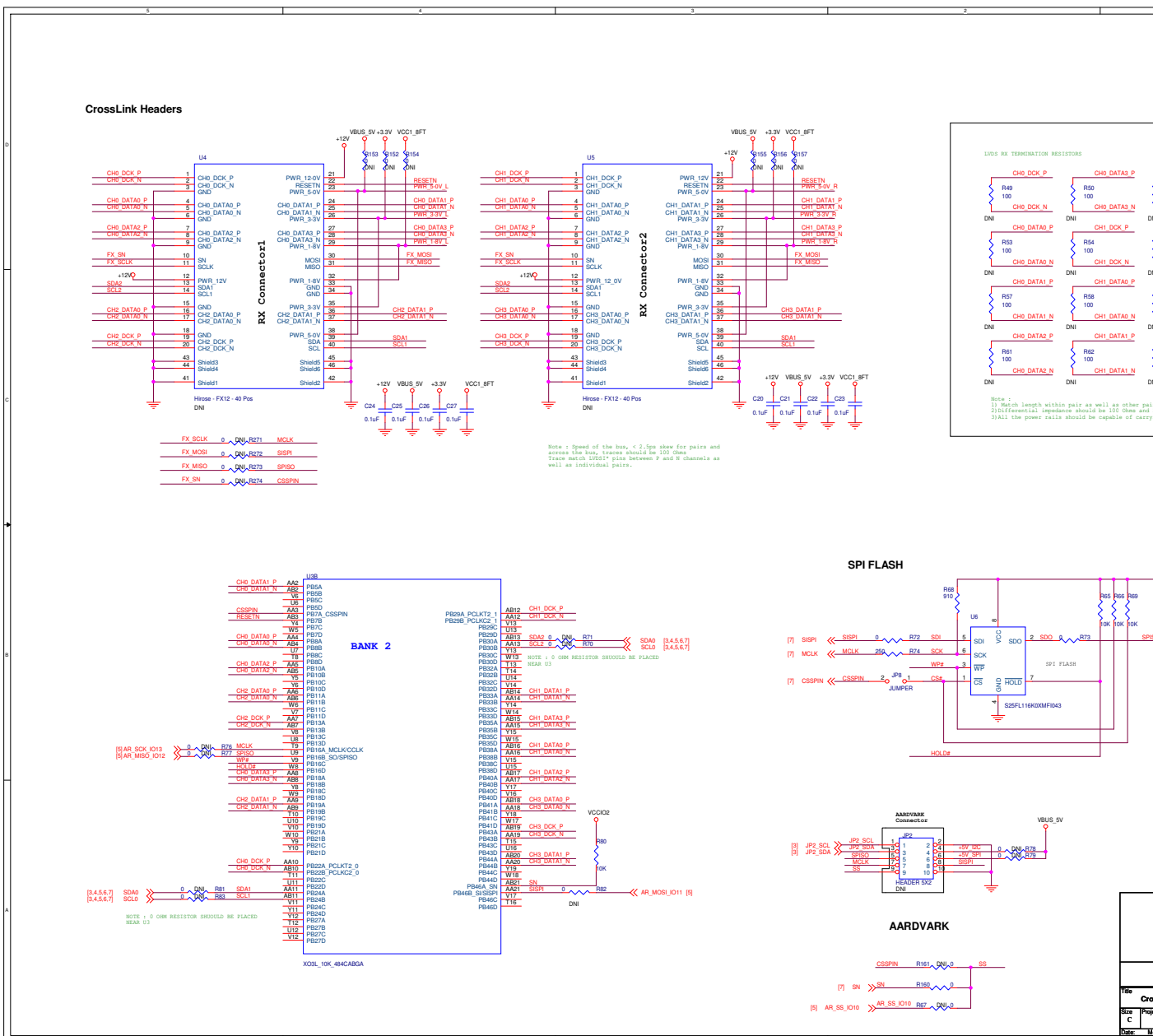

Figure A.6. CrossLink Headers (BANK2)

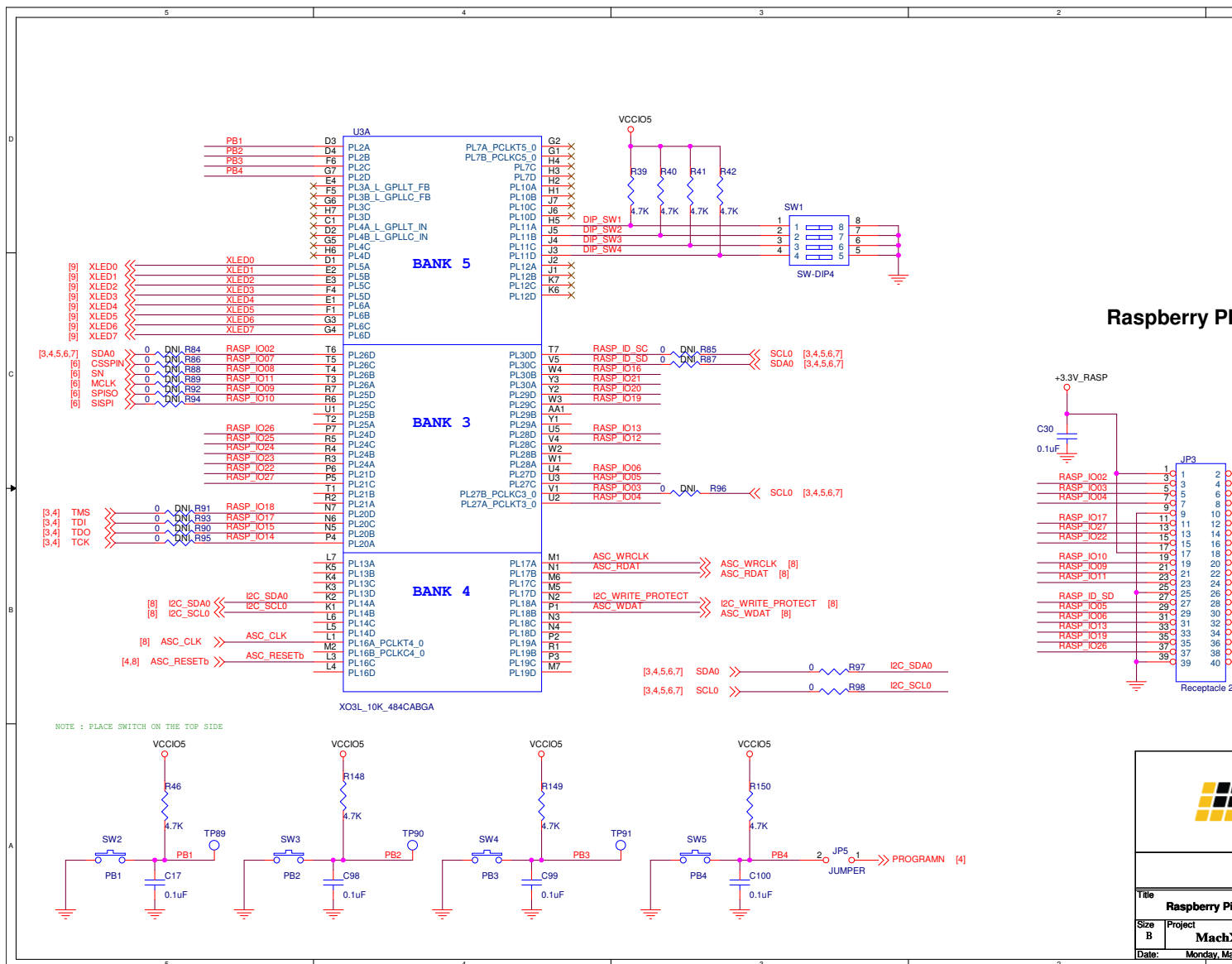

Figure A.7. Raspberry Pi Header and Others (BANK3, BANK4, BANK5)

MachXO3-9400 Development Board
Evaluation Board User Guide

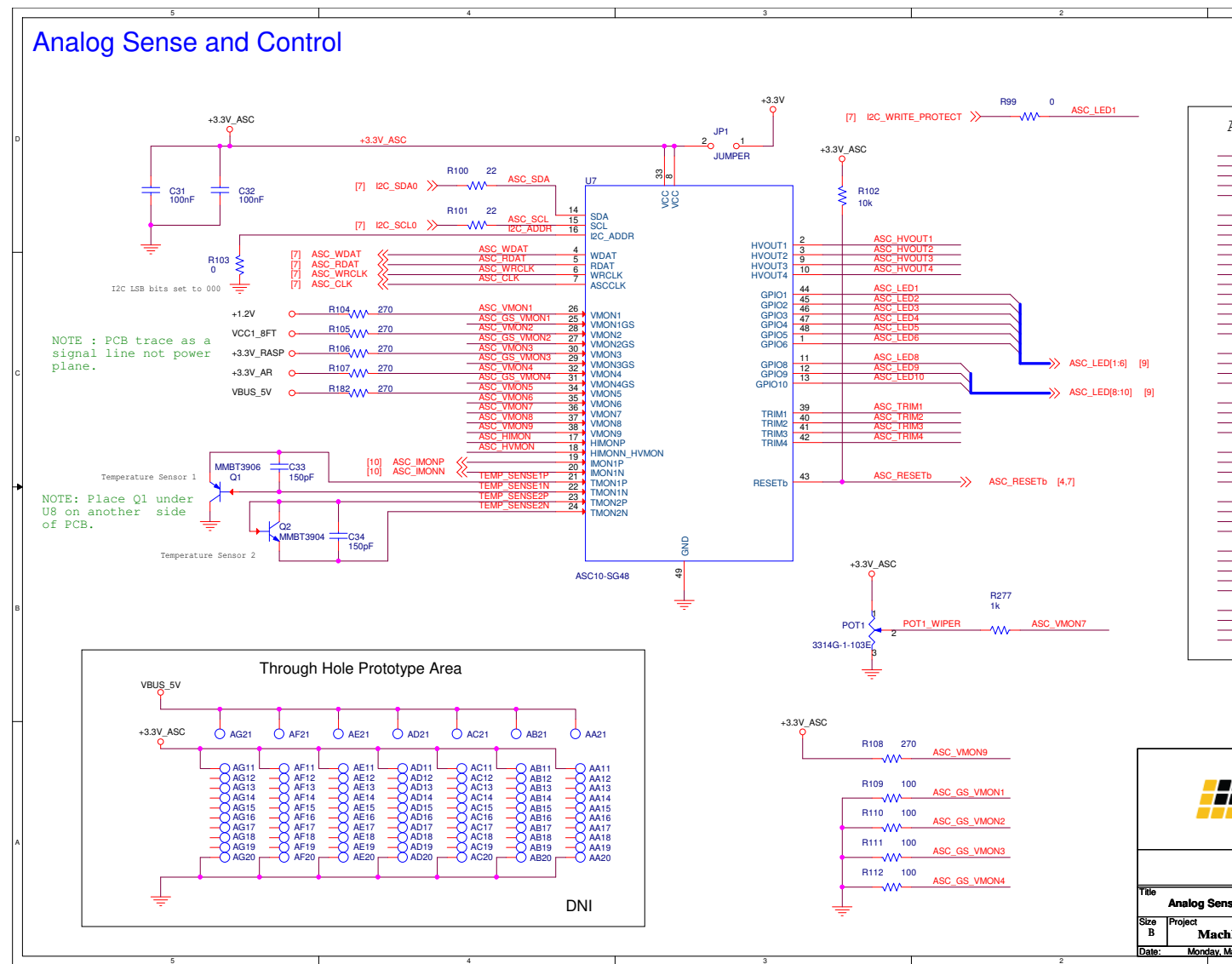

Figure A.8. Analog Sense and Control

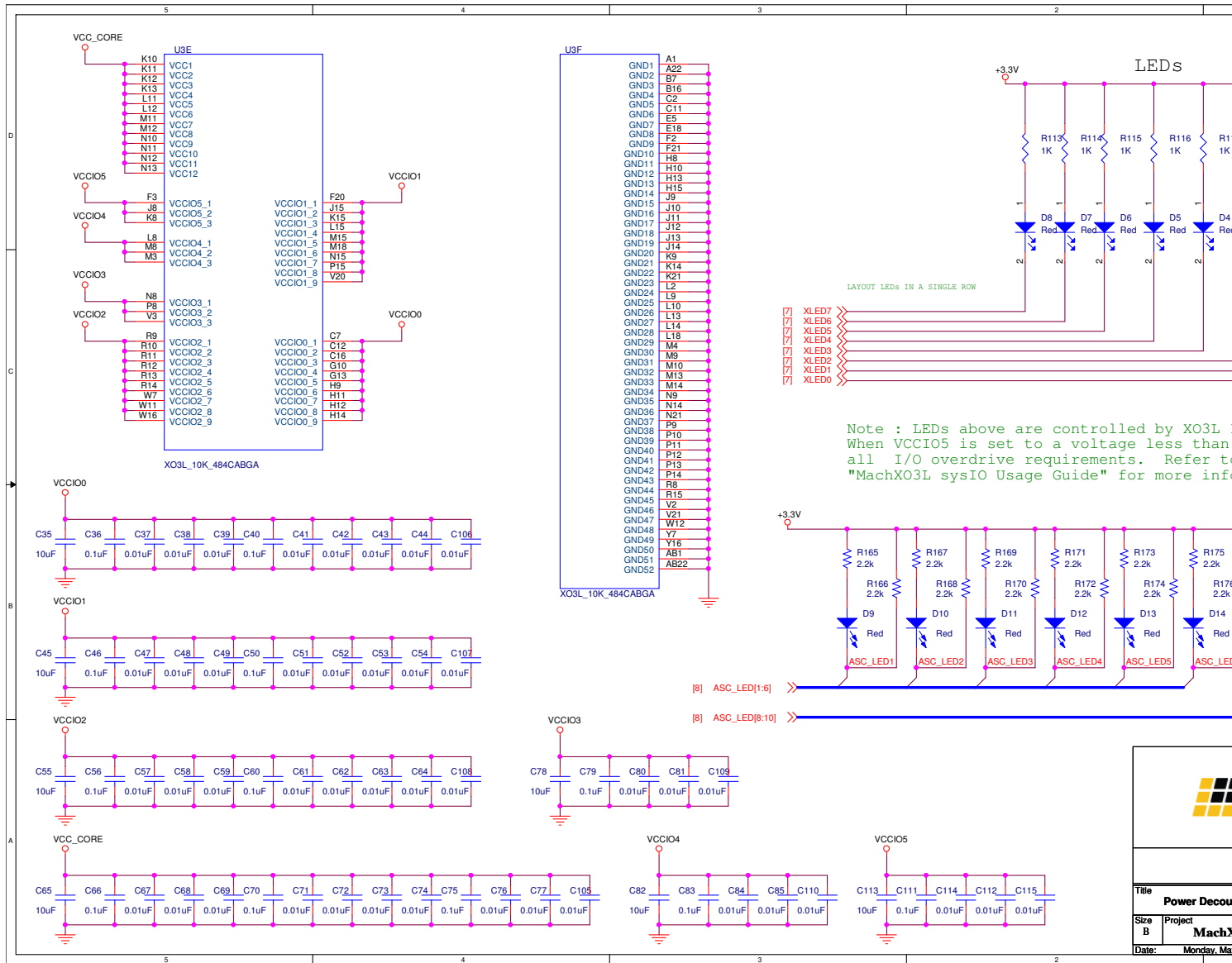

Figure A.9. Power Decoupling and LEDs

MachXO3-9400 Development Board Evaluation Board User Guide

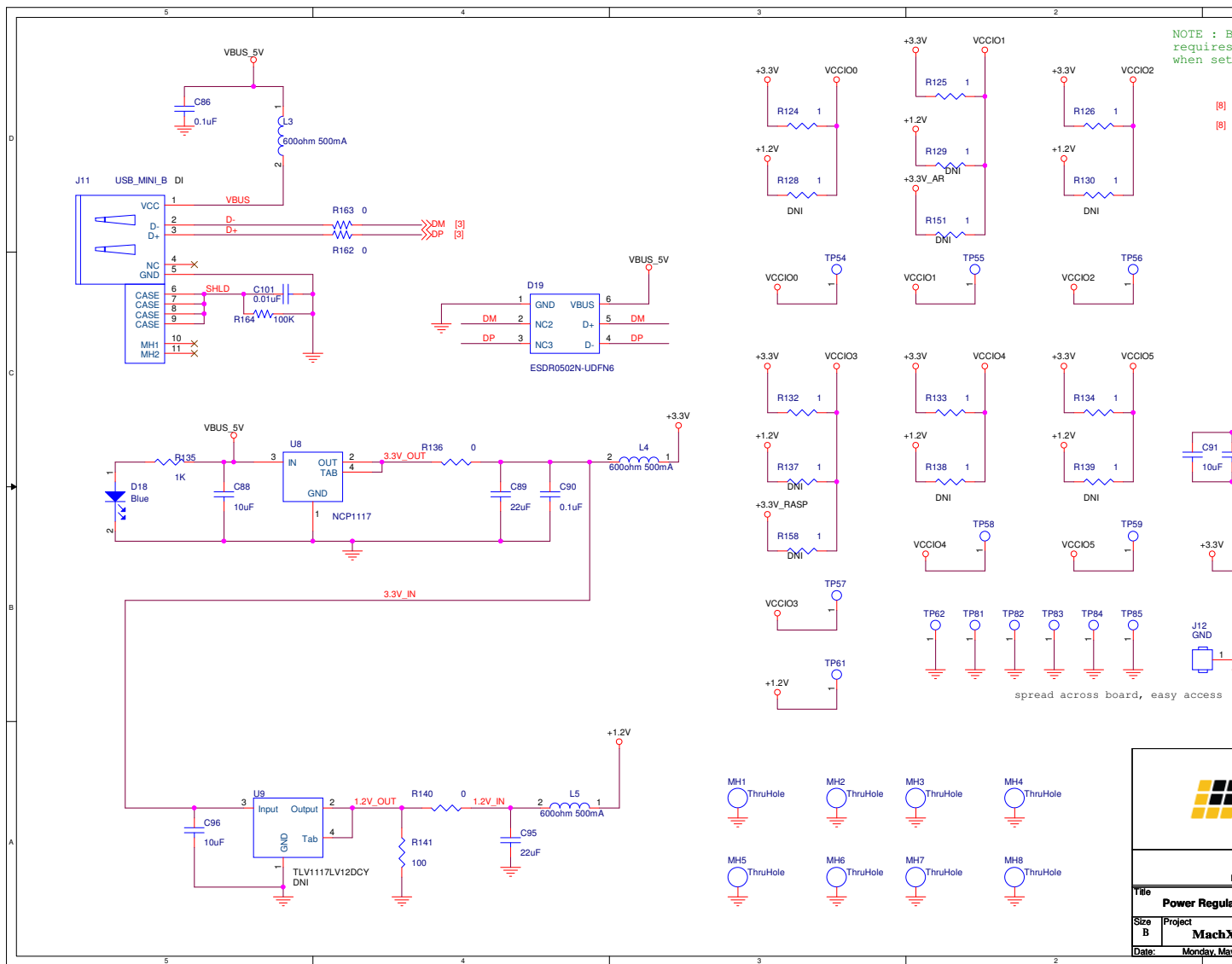

Figure A.10. Power Regulators

Appendix B. MachXO3-9400 Development Board Bill of Materials

Item	Reference	Qty	Part	PCB Footprint	Part Number	Manufacturer	Description	Assembly
1	AG11,AF11,AE11,AD11,AC11,AB11,AA11,AG12,AF12,AE12,AD12,AC12,AB12,AA12,AG13,AF13,AE13,AD13,AC13,AB13,AA13,AG14,AF14,AE14,AD14,AC14,AB14,AA14,AG15,AF15,AE15,AD15,AC15,AB15,AA15,AG16,AF16,AE16,AD16,AC16,AB16,AA16,AG17,AF17,AE17,AD17,AC17,AB17,AA17,AG18,AF18,AE18,AD18,AC18,AB18,AA18,AG19,AF19,AE19,AD19,AC19,AB19,AA19,AG20,AF20,AE20,AD20,AC20,AB20,AA20,AG21,AF21,AE21,AD21,AC21,AB21,AA21	77	T POINT R	TP	—	—	—	DNI
2	C1,C3	2	4.7uF	C0603	CL10A475KA8NQNC	Samsung	CAP CER 4.7UF 6.3V 10% X5R 0603	—
3	C2,C4,C6,C7,C10,C11,C12,C13,C14,C17,C86,C90,C93,C97,C98,C99,C100	17	0.1uF	C0402	CL05B104KA5NNNC	Samsung	CAP CER 0.1UF 16V 10% X7R 0402	—
4	C5,C88,C91,C96	4	10uF	C0603	CL10A106K08NNNC	Samsung	CAP CER 10UF 10V 20% X5R 0603	—
5	C8,C9	2	18pF	C0402	CL05C180JA5NNNC	Samsung	CAP CER 18PF 25V 10% NP0 0402	—
6	C15,C16	2	150pF	C0402	—	—	CAP CER 0.1UF 16V 10% X7R 0402	DNI
7	C20,C21,C22,C23,C24,C25,C26,C27,C29,C30	10	0.1uF	C0402	CL05B104KA5NNNC	Samsung	CAP CER 0.1UF 25V 10% X7R 0402	—

Item	Reference	Qty	Part	PCB Footprint	Part Number	Manufacturer	Description	Assembly
8	C28	1	100nF	C0402	CL05B104KA5NNNC	Samsung	CAP CER 0.1UF 10V 10% X5R 0402	—
9	C31,C32	2	100nF	C0603	CL10B104KA8NNNC	Samsung	—	—
10	C33,C34	2	150pF	C0603	CL10B151KB8NNNC	Samsung	—	—
11	C35,C45,C55,C65, C78,C82,C113	7	10uF	C0603	CL10A106K08NNNC	Samsung	CAP CECAP CER 10UF 10V X5R 20% 0603	—
12	C36,C40,C46,C50, C56,C60,C66,C70, C75,C79,C83,C111	12	0.1uF	C0201	CL03A104KA3NNNC	Samsung	CAP CER 0.1UF 16V 10% X5R 0201	—
13	C37,C38,C39,C41, C42,C43,C44,C47, C48,C49,C51,C52, C53,C54,C57,C58, C59,C61,C62,C63, C64,C67,C68,C69, C71,C72,C73,C74, C76,C77,C80,C81, C84,C85,C105, C106,C107,C108, C109,C110,C112, C114,C115	43	0.01uF	C0201	CL03A103KA3NNNC	Samsung	CAP CER 10000PF 16V 10% X7R 0201	—
14	C89,C95	2	22uF	cc0805	CL21A226KOQNNN E	Samsung	CAP CER 22UF 10V 20% X5R 0805	—
15	C92	1	1uF	C0402	CL05A105KO5NNNC	Samsung	CAP CER 1UF 6.3V 10% X5R 0402	—
16	C94,C101	2	0.01uF	C0402	CL05B103KA5NNNC	Samsung	CAP CER 10000PF 16V 5% X7R 0402	—
17	C103,C104	2	10nF	SM_C_0603	CL10A103KB8NNNC	Samsung	-	—
18	D1,D2,D3,D4,D5, D6,D7,D8,D9,D10, D11,D12,D13,D14, D15,D16,D17,D57	18	Red	led_0603	LTST-C190KRKT	LITE-On INC	LED RED CLEAR 0603 SMD	—
19	D18	1	Blue	led_0603	LTST-C190TBKT	LITE-On INC	LED 468NM BLUE CLEAR 0603 SMD	—
20	D19	1	ESDR0502 N-UDFN6	UDFN6_040	ESDR0502NMUTBG	ON semi	TVS DIODE 5.5VWM 6UDFN	—

Item	Reference	Qty	Part	PCB Footprint	Part Number	Manufacturer	Description	Assembly
21	J1	1	Header 1x8	hdr_amp_87 220_8_1x8_100	22284081	Molex	CONN HEADER 8POS .100 VERT TIN	DNI
22	J2	1	Header 1x10	CONF1X10-254P_2612X 240X850H_T H	—	—	CONN HEADER 10POS .100 VERT TIN	DNI
23	J3,J4	2	Header 1x8	CONF1X8-254P_2104X 240X850H_T H	—	—	CONN HEADER 8POS .100 VERT TIN	DNI
24	J5	1	Header 1x6	CONF1X6-254P_1596X 240X850H_T H	—	—	CONN HEADER 6POS .100 VERT TIN	DNI
25	J10	1	SMA	bnc5-100-280t	5-1814832-1	TE Connectivity	CONN SMA JACK STR 50 OHM PCB	DNI
26	J11	1	USB_MINI_B	usb2-0-rec-240-0001-9	UX60-MB-5ST	Hirose	CONN RECEPT MINI USB2.0 5POS	—
27	J12, J13	2	GND	TUR_TH	1573-2	Keystone Electronics	Terminal Turret Connector Single End 0.186" (4.72mm) Tin	DNI
28	JP1,JP4,JP5,JP6,JP7,JP8,JP9,JP10,JP11	9	JUMPER	Header_1x2	—	—	CONN HEADER 2POS .100 VERT TIN	—
29	JP2	1	HEADER 5X2	HDR254-2X5_SHROUDED	30310-6002HB	3M	CONN HEADER 10POS DL STR GOLD	—
30	JP3	1	Receptacle 20X2	HDR254-2X20_socket	PPTC202LFBN-RC	Sullins	CONN HEADER FEM 40POS .1" DL TIN	DNI
31	L1,L2,L3,L4,L5	5	600ohm 500mA	fb0603	BLM18AG601SN1D	Murata	FERRITE CHIP 600 OHM 500MA 0603	—
32	MH1,MH2,MH3,MH4,MH5,MH6,MH7,MH8	8	ThruHole	MTG125	—	—	—	DNI
33	POT1	1	3314G-1-103E	sot23-3314G-1	3314G-1-103E	Bourns Inc.	TRIMMER 10K OHM 0.25W SMD	—

Item	Reference	Qty	Part	PCB Footprint	Part Number	Manufacturer	Description	Assembly
34	Q1	1	MMBT3906	MMBT3906	MMBT3906	Fairchild	TRANS PNP 40V 0.2A SOT-23	—
35	Q2,Q42	2	MMBT3904	MMBT3904	MMBT3904	Fairchild	TRANS NPN 40V 0.2A SOT-23	—
36	R1,R2,R3,R39,R40, R41,R42,R46, R148,R149, R150,R263	12	4.7k	R0603	RC0603FR-074K7L	Yageo	RES 4.70K OHM 1/10W 1% 0603 SMD	—
37	R4,R5,R6,R7,R23, R24,R25,R31,R72, R73,R99,R103, R136,R140,R269,R 270	16	0	R0603	RC0603FR-070RL	Yageo	RES 0.0 OHM 1/10W JUMP 0603 SMD	—
38	R8,R9,R121,R122, R165,R166,R167, R168,R169,R170, R171,R172,R173, R174,R175,R176, R177,R178,R179, R180	20	2.2k	R0603	RC0603FR-072K2L	Yageo	—	—
39	R10,R19	2	12K	R0603	RC0603FR-0712KL	Yageo	RES 12K OHM 1/10W 1% 0603 SMD	—
40	R11,R12,R13,R65, R66,R69,R80, R102,R145, R202,R265,R266, R267,R268	14	10K	R0603	RC0603FR-0710KL	Yageo	RES 10K OHM 1/10W 5% 0603	—
41	R14,R15,R16,R17, R18,R20,R21,R22, R84,R85,R86,R87, R88,R89,R90,R91, R92,R93,R94,R95, R96,R278	22	0	R0603	—	—	RES 0.0 OHM 1/10W JUMP 0603 SMD	DNI
42	R30,R146,R147, R159,R275	5	0R- 0603SMT	R0603	—	—	RES 0.0 OHM 1/10W JUMP 0603 SMD	DNI
43	R33,R34	2	2K	R0603	RC0603FR-072KL	Yageo	RES 2.0K OHM 1/10W 5% 0603 SMD	—
44	R35,R37	2	49.9	R0603	RC0603FR-0749R9L	Yageo	RES 49.9 OHM 1/10W 1% 0603 SMD	—
45	R36,R38	2	150	R0603	RC0603FR-07151RL	Yageo	RES 150 OHM 1/10W 5% 0603 SMD	—

Item	Reference	Qty	Part	PCB Footprint	Part Number	Manufacturer	Description	Assembly
46	R43,R44,R45,R67, R70,R71,R76,R77, R78,R79,R81,R82, R83,R152,R153, R154,R155,R156, R157,R161,R271, R272,R273,R274	24	0	R0603	—	—	Res 1/10W 0.0 Ohm 5% 0603	DNI
47	R49,R50,R51,R52, R53,R54,R55,R56, R57,R58,R59,R60, R61,R62,R63,R64	16	100	R0402	—	—	RES SMD 100 OHM 1% 1/16W 0402	DNI
48	R113,R114, R115,R116,R117, R118,R119,R120, R135,R262,R277	11	1k	R0603	RC0603FR-071KL	Yageo	RES 1K OHM 1/10W 1% 0603 SMD	—
49	R97,R98,R160	3	0	R0603	RC0603FR-070RL	Yageo	Res 1/10W 0.0 Ohm 5% 0603	—
50	R100,R101	2	22	R0603	RC0603FR-0722RL	Yageo	—	—
51	R104,R105,R106, R107,R108,R182	6	270	R0603	RC0603FR-07270RL	Yageo	—	—
52	R109,R110,R111, R112	4	100	R0603	RC0603FR-07100RL	Yageo	—	—
53	R123,R124,R125, R126,R132,R133, R134	7	1	R0603	RC0603FR-071RL	Yageo	RES 1.0 OHM .25W 5% 0603 SMD	—
54	R127,R128,R129, R130,R137,R138, R139,R151,R158	9	1	R0603	-	Yageo	RES 1.0 OHM .25W 5% 0603 SMD	DNI
55	R141	1	100	R0603	RC0603FR-07100RL	Yageo	RES 100 OHM 1/10W 1% 0603 SMD	—
56	R144,R162,R163	3	0	R0402	RC0402FR-070RL	Yageo	—	—
57	R164	1	100K	R0603	RC0603FR-07100KL	Yageo	—	—
58	R181	1	0.02	SM_R_ 1206	RL1206FR-070R02L	Yageo	—	—
59	R264	1	470	R0603	RC0603FR-07470RL	Yageo	—	—
60	SW1	1	SW-DIP4	sw_sp_st_ cts_195- 4mst	195-4MST	CTS	SWITCH PIANO DIP SPST 50MA 24V	—
61	SW2	1	PB1	sw_sp_st_ eswitch_ tl1015	TL1015AF160QG	E-Switch	SWITCH TACTILE SPST-NO 0.05A 12V	—
62	SW3	1	PB2	sw_sp_st_ eswitch_ tl1015	TL1015AF160QG	E-Switch	SWITCH TACTILE SPST-NO 0.05A 12V	—

Item	Reference	Qty	Part	PCB Footprint	Part Number	Manufacturer	Description	Assembly
63	SW4	1	PB3	sw_sp_st_ eswitch_ tl1015	TL1015AF160QG	E-Switch	SWITCH TACTILE SPST-NO 0.05A 12V	—
64	SW5	1	PB4	sw_sp_st_ eswitch_ tl1015	TL1015AF160QG	E-Switch	SWITCH TACTILE SPST-NO 0.05A 12V	—
65	TP1,TP2,TP53, TP54,TP55,TP56, TP57,TP58,TP59, TP60,TP61,TP62, TP81, TP82, TP83, TP84, TP85	17	TP_S_40_ 63	TP	—	—	Square test point, 40mil inner diameter, 63mil outer diameter	DNI
66	TP10,TP11,TP12, TP13,TP14,TP15, TP16,TP17,TP18, TP19,TP20,TP21, TP22,TP23,TP24, TP25,TP26,TP27, TP28,TP29,TP30, TP31,TP32,TP33, TP34,TP35,TP36, TP37,TP38,TP39, TP40,TP41,TP42, TP43,TP44,TP45, TP46,TP47,TP48, TP49,TP50,TP51, TP52,TP63,TP64, TP65,TP66,TP67, TP68,TP69,TP70, TP71,TP72,TP73, TP74,TP75,TP76, TP77,TP78,TP79, TP80	61	T POINT R	TP	—	—	—	DNI
67	TP6,TP7,TP8, TP89,TP90,TP91	6	TestPoint	TP	—	—	—	DNI
68	TP93,TP94,TP95, TP96,TP97,TP98, TP99,TP100, TP101,TP102	10	T POINT R	TPC32	—	—	—	DNI
69	U1	1	FT2232HL	tqfp64_ 0p5_12p2x1 2p2_h1p6	FT2232HL-TRAY	FTDI	IC USB HS DUAL UART/FIFO 64-LQFP	—
70	U2	1	93LC56C- I/SN	so8_50_ 244	93LC56C-I/SN	Microchip	IC EEPROM 2KBIT 3MHZ 8SOIC	—
71	U3	1	XO3L_10K _484CAB GA	BGA484-080	LCMXO3LF-9400C- 6BG484C	Lattice	XO3LF-9400 CPLD device	—

Item	Reference	Qty	Part	PCB Footprint	Part Number	Manufacturer	Description	Assembly
72	U4,U5	2	Hirose - FX12 - 40 Pos	Hirose-FX12	FX12B-40P-0.4SV	Hirose	CONN PLUG 40POS 0.4MM SMD SHIELD	DNI
73	U6	1	S25FL116 K0XMF104 3	so8_50_244	S25FL116K0XMF104 3	Cypress	IC FLASH 16MBIT 108MHZ 8SOIC	—
74	U7	1	ASC10-SG48	TQFN_48	L-ASC10-1SG48I	Lattice	ASC Device	—
75	U8	1	NCP1117	sot223_4p	NCP1117ST33T3G	ON semi	IC REG LDO 3.3V 1A SOT223	—
76	U9	1		sot223_4p	—	—	IC REG LDO SOT223-3	DNI
77	U10,U11	2	FSA4157_ Analog_Sw	SOP-6-26	FSA4157P6X	Fairchild	IC SWITCH SPDT SC70-6	—
78	X1	1	7M-12.000MAAJ	xtal_4p_7m	7M-12.000MAAJ-T	TXC	CRYSTAL 12MHZ 18PF SMD	—
79	X2,X3	2	HDR40	HDR-20x2	—	—	CON M 20x2 THT RM2.54 square Au 1002 Series 11.4x5.8x2.5 0.635mm	DNI
80	Y2	1	ASDMB-XX.XXXM Hz	x4-2520	ASDMB seria	Abracon LLC	OSC MEMS CMOS SMD	DNI
81	R68	1	910	R0603	—	—	—	—
82	R74	1	250	R0603	—	—	—	—

Appendix C. Predefined Preference File Listing

```
// These names are generated by the Platform Designer tool in Diamond software  
// and can be copied into the preference file or entered into the Spreadsheet  
// view.
```

```
// ASC0 Connections  
LOCATE COMP "ASC0_RSTN" SITE "L3" ;  
LOCATE COMP "ASC0_CLK" SITE "L1" ;  
LOCATE COMP "rdat_0" SITE "N1" ;  
LOCATE COMP "wdat_0" SITE "P1" ;  
LOCATE COMP "wrclk_0" SITE "M1" ;
```

Appendix D. User Defined Preference File Listing

```
// These names follow the MachXO3 9400 Development Board schematic but,  
// they may be defined by the user. Thus, they can be copied into the  
// preference file and edited to match a different naming convention if  
// needed or used to fill in the Spreadsheet view.
```

```
// X03 LED Connections  
// Note: The following order matches the LED locations on the board  
// from top to bottom
```

```
LOCATE COMP "XLED3" SITE "F4" ;  
LOCATE COMP "XLED7" SITE "G4" ;  
LOCATE COMP "XLED6" SITE "G3" ;  
LOCATE COMP "XLED0" SITE "D1" ;  
LOCATE COMP "XLED1" SITE "E2" ;  
LOCATE COMP "XLED4" SITE "E1" ;  
LOCATE COMP "XLED2" SITE "E3" ;  
LOCATE COMP "XLED5" SITE "F1" ;
```

```
// X03 DIP Switch Connections
```

```
LOCATE COMP "DIP_SW1" SITE "H5" ;  
LOCATE COMP "DIP_SW2" SITE "J5" ;  
LOCATE COMP "DIP_SW3" SITE "J4" ;  
LOCATE COMP "DIP_SW4" SITE "J3" ;
```

```
// X03 Push Button Switch Connections
```

```
LOCATE COMP "PB1" SITE "D3" ;  
LOCATE COMP "PB2" SITE "D4" ;  
LOCATE COMP "PB3" SITE "F6" ;  
LOCATE COMP "PB4" SITE "G7" ;
```

```
// X03 Clock Connections
```

```
LOCATE COMP "12MHZ" SITE "B10" ;  
LOCATE COMP "OSC_IN" SITE "D22" ;  
LOCATE COMP "OSC_EN" SITE "L20" ;
```

```
// X03 SPI Flash Connections
```

```
LOCATE COMP "CSSPIN" SITE "AA3" ;  
LOCATE COMP "MCLK" SITE "T9" ;  
LOCATE COMP "SISPI" SITE "AA21" ;  
LOCATE COMP "SPIISO" SITE "U9" ;  
LOCATE COMP "WP#" SITE "V9" ;  
LOCATE COMP "HOLD#" SITE "W8" ;
```

```
// X03 ARDUINO Connections
```

```
LOCATE COMP "AR_AD0" SITE "P19" ;  
LOCATE COMP "AR_AD1" SITE "P18" ;  
LOCATE COMP "AR_AD2" SITE "P17" ;  
LOCATE COMP "AR_AD3" SITE "P16" ;  
LOCATE COMP "AR_AD4" SITE "K22" ;  
LOCATE COMP "AR_AD5" SITE "G17" ;
```

```
LOCATE COMP "AR_IO0" SITE "G19" ;  
LOCATE COMP "AR_IO1" SITE "G20" ;  
LOCATE COMP "AR_IO2" SITE "G21" ;  
LOCATE COMP "AR_IO3" SITE "H20" ;  
LOCATE COMP "AR_IO4" SITE "G18" ;
```

```
// XO3 ARDUINO Connections continued
LOCATE COMP "AR_IO5" SITE "L21" ;
LOCATE COMP "AR_IO6" SITE "W22" ;
LOCATE COMP "AR_IO7" SITE "V22" ;
LOCATE COMP "AR_IO8" SITE "U21" ;
LOCATE COMP "AR_IO9" SITE "U22" ;

LOCATE COMP "AR_SS_IO10" SITE "W20" ;
LOCATE COMP "AR_MOSI_IO11" SITE "V18" ;
LOCATE COMP "AR_MISO_IO12" SITE "G16" ;
LOCATE COMP "AR_SCK_IO13" SITE "F17" ;
LOCATE COMP "AR_IO14" SITE "T17" ;
LOCATE COMP "AR_AREF" SITE "U17" ;
LOCATE COMP "AR_SDA" SITE "U19" ;
LOCATE COMP "AR_SCL" SITE "U18" ;
LOCATE COMP "AR_RESET" SITE "U20" ;

// XO3 Raspberry Pi Connections
LOCATE COMP "RASP_IO02" SITE "T6" ;
LOCATE COMP "RASP_IO03" SITE "V1" ;
LOCATE COMP "RASP_IO04" SITE "U2" ;
LOCATE COMP "RASP_IO05" SITE "U3" ;
LOCATE COMP "RASP_IO06" SITE "U4" ;
LOCATE COMP "RASP_IO07" SITE "T5" ;
LOCATE COMP "RASP_IO08" SITE "T4" ;
LOCATE COMP "RASP_IO09" SITE "R7" ;
LOCATE COMP "RASP_IO10" SITE "R6" ;
LOCATE COMP "RASP_IO11" SITE "T3" ;
LOCATE COMP "RASP_IO12" SITE "V4" ;
LOCATE COMP "RASP_IO13" SITE "U5" ;
LOCATE COMP "RASP_IO14" SITE "P4" ;
LOCATE COMP "RASP_IO15" SITE "N5" ;
LOCATE COMP "RASP_IO16" SITE "W4" ;
LOCATE COMP "RASP_IO17" SITE "N6" ;
LOCATE COMP "RASP_IO18" SITE "N7" ;
LOCATE COMP "RASP_IO19" SITE "W3" ;
LOCATE COMP "RASP_IO20" SITE "Y2" ;
LOCATE COMP "RASP_IO21" SITE "Y3" ;
LOCATE COMP "RASP_IO22" SITE "P6" ;
LOCATE COMP "RASP_IO23" SITE "R3" ;
LOCATE COMP "RASP_IO24" SITE "R4" ;
LOCATE COMP "RASP_IO25" SITE "R5" ;

LOCATE COMP "RASP_ID_SD" SITE "V5" ;
LOCATE COMP "RASP_ID_SC" SITE "T7" ;

// XO3 VERSA Connections
LOCATE COMP "EXPCON_IO0" SITE "F8" ;
LOCATE COMP "EXPCON_IO1" SITE "G8" ;
LOCATE COMP "EXPCON_IO2" SITE "F9" ;
LOCATE COMP "EXPCON_IO3" SITE "F7" ;
LOCATE COMP "EXPCON_IO4" SITE "E7" ;
LOCATE COMP "EXPCON_IO5" SITE "E6" ;
LOCATE COMP "EXPCON_IO6" SITE "D5" ;
LOCATE COMP "EXPCON_IO7" SITE "C3" ;
LOCATE COMP "EXPCON_IO8" SITE "D6" ;
LOCATE COMP "EXPCON_IO9" SITE "C4" ;
LOCATE COMP "EXPCON_IO10" SITE "F10" ;
```



```
// XO3 VERSA Connections Continued
LOCATE COMP "EXPCON_IO11" SITE "C5" ;
LOCATE COMP "EXPCON_IO12" SITE "C6" ;
LOCATE COMP "EXPCON_IO13" SITE "B2" ;
LOCATE COMP "EXPCON_IO14" SITE "D7" ;
LOCATE COMP "EXPCON_IO15" SITE "A12" ;
LOCATE COMP "EXPCON_IO16" SITE "D8" ;
LOCATE COMP "EXPCON_IO17" SITE "C8" ;
LOCATE COMP "EXPCON_IO18" SITE "D9" ;
LOCATE COMP "EXPCON_IO19" SITE "E10" ;
LOCATE COMP "EXPCON_IO20" SITE "C9" ;
LOCATE COMP "EXPCON_IO21" SITE "G11" ;
LOCATE COMP "EXPCON_IO22" SITE "E11" ;
LOCATE COMP "EXPCON_IO23" SITE "D11" ;
LOCATE COMP "EXPCON_IO24" SITE "F11" ;
LOCATE COMP "EXPCON_IO25" SITE "D12" ;
LOCATE COMP "EXPCON_IO26" SITE "F12" ;
LOCATE COMP "EXPCON_IO27" SITE "D13" ;
LOCATE COMP "EXPCON_IO28" SITE "C14" ;
LOCATE COMP "EXPCON_IO29" SITE "E12" ;
LOCATE COMP "EXPCON_IO30" SITE "D14" ;
LOCATE COMP "EXPCON_IO31" SITE "C15" ;
LOCATE COMP "EXPCON_IO32" SITE "C17" ;
LOCATE COMP "EXPCON_IO33" SITE "D15" ;
LOCATE COMP "EXPCON_IO34" SITE "C18" ;
LOCATE COMP "EXPCON_IO35" SITE "D16" ;
LOCATE COMP "EXPCON_IO36" SITE "C19" ;
LOCATE COMP "EXPCON_IO37" SITE "D17" ;
LOCATE COMP "EXPCON_IO38" SITE "D18" ;
LOCATE COMP "EXPCON_IO39" SITE "C20" ;
LOCATE COMP "EXPCON_IO40" SITE "E16" ;
LOCATE COMP "EXPCON_IO41" SITE "E13" ;
LOCATE COMP "EXPCON_IO42" SITE "F13" ;
LOCATE COMP "EXPCON_IO43" SITE "F15" ;
LOCATE COMP "EXPCON_IO44" SITE "G15" ;
LOCATE COMP "EXPCON_IO45" SITE "G12" ;
LOCATE COMP "EXPCON_OSC" SITE "D22" ;
LOCATE COMP "EXPCON_CLKIN" SITE "A10" ;
LOCATE COMP "EXPCON_CLKOUT" SITE "A21" ;
LOCATE COMP "CARDSEL#" SITE "C13" ;
LOCATE COMP "HPE_RESOUT#" SITE "G9" ;
```

```
// XO3 LVDS Test Connections
LOCATE COMP "LVDS_OUT0_P" SITE "B1" ;
LOCATE COMP "LVDS_OUT0_N" SITE "A2" ;
LOCATE COMP "LVDS_OUT1_P" SITE "B2" ;
LOCATE COMP "LVDS_OUT1_N" SITE "A3" ;
LOCATE COMP "LVDS_OUT2_P" SITE "B3" ;
LOCATE COMP "LVDS_OUT2_N" SITE "A4" ;
LOCATE COMP "LVDS_OUT3_P" SITE "B4" ;
LOCATE COMP "LVDS_OUT3_N" SITE "A5" ;
LOCATE COMP "LVDS_OUT4_P" SITE "B5" ;
LOCATE COMP "LVDS_OUT4_N" SITE "A6" ;
LOCATE COMP "LVDS_OUT5_P" SITE "B6" ;
LOCATE COMP "LVDS_OUT5_N" SITE "A7" ;
LOCATE COMP "LVDS_OUT6_P" SITE "B8" ;
LOCATE COMP "LVDS_OUT6_N" SITE "A8" ;
LOCATE COMP "LVDS_OUT7_P" SITE "B9" ;
```

```
// XO3 LVDS Test Connections Continued
LOCATE COMP "LVDS_OUT7_N" SITE "A9" ;
LOCATE COMP "LVDS_OUT8_P" SITE "B11" ;
LOCATE COMP "LVDS_OUT8_N" SITE "A11" ;

// XO3 GDDR Test Connections
LOCATE COMP "GDDR_DQ0" SITE "R22" ;
LOCATE COMP "GDDR_DQ1" SITE "R21" ;
LOCATE COMP "GDDR_DQ2" SITE "T22" ;
LOCATE COMP "GDDR_DQ3" SITE "T21" ;
LOCATE COMP "GDDR_DQ4" SITE "Y22" ;
LOCATE COMP "GDDR_DQ5" SITE "W21" ;
LOCATE COMP "GDDR_DQ6" SITE "AA22" ;
LOCATE COMP "GDDR_DQ7" SITE "Y21" ;
LOCATE COMP "GDDR_DQS" SITE "N22" ;

// XO3 CrossLink Connections
LOCATE COMP "CH0_DCK_P" SITE "AA10" ;
LOCATE COMP "CH0_DCK_N" SITE "AB10" ;
LOCATE COMP "CH0_DATA0_P" SITE "AA4" ;
LOCATE COMP "CH0_DATA0_N" SITE "AB4" ;
LOCATE COMP "CH0_DATA1_P" SITE "AA2" ;
LOCATE COMP "CH0_DATA1_N" SITE "AB2" ;
LOCATE COMP "CH0_DATA2_P" SITE "AA5" ;
LOCATE COMP "CH0_DATA2_N" SITE "AB5" ;
LOCATE COMP "CH0_DATA3_P" SITE "AA8" ;
LOCATE COMP "CH0_DATA3_N" SITE "AB8" ;

LOCATE COMP "CH1_DCK_P" SITE "AB12" ;
LOCATE COMP "CH1_DCK_N" SITE "AA12" ;
LOCATE COMP "CH1_DATA0_P" SITE "AB16" ;
LOCATE COMP "CH1_DATA0_N" SITE "AA16" ;
LOCATE COMP "CH1_DATA1_P" SITE "AB14" ;
LOCATE COMP "CH1_DATA1_N" SITE "AA14" ;
LOCATE COMP "CH1_DATA2_P" SITE "AB17" ;
LOCATE COMP "CH1_DATA2_N" SITE "AA17" ;
LOCATE COMP "CH1_DATA3_P" SITE "AB15" ;
LOCATE COMP "CH1_DATA3_N" SITE "AA15" ;

LOCATE COMP "CH2_DCK_P" SITE "AA7" ;
LOCATE COMP "CH2_DCK_N" SITE "AB7" ;
LOCATE COMP "CH2_DATA0_P" SITE "AA6" ;
LOCATE COMP "CH2_DATA0_N" SITE "AB6" ;
LOCATE COMP "CH2_DATA1_P" SITE "AA9" ;
LOCATE COMP "CH2_DATA1_N" SITE "AB9" ;

LOCATE COMP "CH3_DCK_P" SITE "AB19" ;
LOCATE COMP "CH3_DCK_N" SITE "AA19" ;
LOCATE COMP "CH3_DATA0_P" SITE "AB18" ;
LOCATE COMP "CH3_DATA0_N" SITE "AA18" ;
LOCATE COMP "CH3_DATA1_P" SITE "AB20" ;
LOCATE COMP "CH3_DATA1_N" SITE "AA20" ;

LOCATE COMP "SDA1" SITE "AA11" ;
LOCATE COMP "SCL1" SITE "AB11" ;
LOCATE COMP "SDA2" SITE "AB13" ;
LOCATE COMP "SCL2" SITE "AA13" ;
```

```
// X03 CrossLink Connections Continued
LOCATE COMP "FX_SN"          SITE "AA3" ;
LOCATE COMP "FX_SCLK"       SITE "T9"  ;
LOCATE COMP "FX_MOSI"       SITE "AA21" ;
LOCATE COMP "FX_MISO"       SITE "U9"  ;
LOCATE COMP "RESETN"        SITE "AB3" ;
```

Revision History

Date	Version	Change Summary
May 2017	1.0	Initial release.



7th Floor, 111 SW 5th Avenue
Portland, OR 97204, USA
T 503.268.8000
www.latticesemi.com

X-ON Electronics

Largest Supplier of Electrical and Electronic Components

Click to view similar products for [Programmable Logic IC Development Tools](#) category:

Click to view products by [Lattice](#) manufacturer:

Other Similar products are found below :

[HLDC-DDR3-A](#) [DK-DEV-5SGXEA7N](#) [EK-10M50F484](#) [EPXA4F672C2](#) [EPXA4F672C3](#) [EPXA4F672C1](#) [P0435](#) [K0161](#) [LCMXO256C-S-EVN](#) [12GSDIFMCCD](#) [SFP+X4FMCCD](#) [88980182](#) [P0582](#) [HW-PWAC-2600317](#) [DEV-17514](#) [LCMXO3D-9400HC-B-EVN](#) [P0671](#) [DK-K7-CONN-G](#) [P0467](#) [LCMXO2-1200ZE-P1-EVN](#) [LCMXO2-4000HE-DSIB-EVN](#) [DK-DEV-4SGX530N](#) [LCMXO3L-SMA-EVN](#) [P006-006-2](#) [EK-U1-VCU108-G](#) [A2F500-DEV-KIT-2](#) [LCMXO3LF-9400C-ASC-B-EVN](#) [471-014](#) [EVAL-TPG-ZYNQ3](#) [SL001](#) [80-001005](#) [P0466-EDU](#) [EK-10CL025U256](#) [P0496](#) [P0493](#) [DK-SOC-10AS066S-A](#) [DK-DEV-10CX220-A](#) [80-001002](#) [iCE40UP5K-MDP-EVN](#) [RXCA10S066PF34-IDK00A](#) [ALTSODIAC5ST](#) [ALTHYDRAC5GX](#) [ALTNITROC5GX](#) [ALTBERYLLC5GX](#) [471-015](#) [LFE3-17EA-USB3-EVN](#) [1553](#) [4332](#) [Hinj](#)
[HinjKit](#)