

Product description **Polzahl: 7 DIN, Kabeldose mit Schirmring, schirmbar, Kabeldurchlass 6 - 8 mm, versilberte Kontakte, mit UL-Zulassung**  
 Area **M16 IP67 Series 423**  
 Order number **99 5682 15 07**

**Illustration**

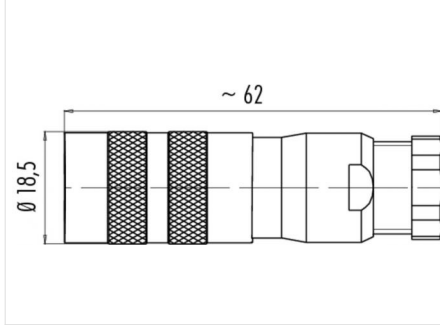

**Scale drawing**



**Contact arrangement**

	X	Y
1	-3,50	0,00
2	0,00	3,50
3	3,50	0,00
4	-2,47	2,47
5	2,47	2,47
6	-2,47	-2,47
7	2,47	-2,47

**Attenuation characteristics**

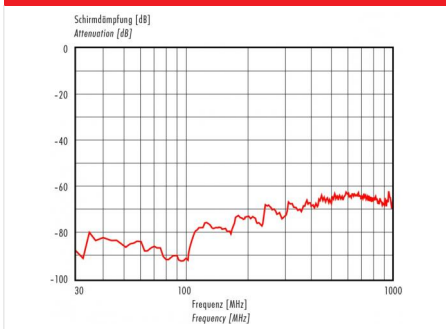

You can find the component part drawing and assembly instructions on the next page.

**Technical data**

**General values**

Connector design Female cable connector  
 Connector locking system bolted  
 Termination solder  
 Wire gauge (mm) 0,75 mm<sup>2</sup>  
 Wire gauge (AWG) 20  
 Cable outlet 6 – 8 mm  
 Upper limit temperature 95 °C  
 Lower limit temperature -30 °C

**Electrical values**

Rated voltage 60 V  
 Rated impulse voltage 800 V  
 Pollution degree 1  
 Overvoltage category I  
 Insulating material group III  
 Rated current (40 °C) 5 A  
 Volume resistivity ≤ 5 mΩ  
 EMC compliance shieldable  
 Degree of protection IP67  
 Mechanical operation > 500 Mating cycles

**Cable data**

Approval 1 UL

**Material**

Contact material CuSn (Bronze)  
 Contact plating Ag (silver)  
 Contact body material PBT (UL 94 V-0)

Product description	<b>Polzahl: 7 DIN, Kabeldose mit Schirmring, schirmbar, Kabeldurchlass 6 - 8 mm, versilberte Kontakte, mit UL-Zulassung</b>
Area	<b>M16 IP67 Series 423</b>
Order number	<b>99 5682 15 07</b>

Component part drawing

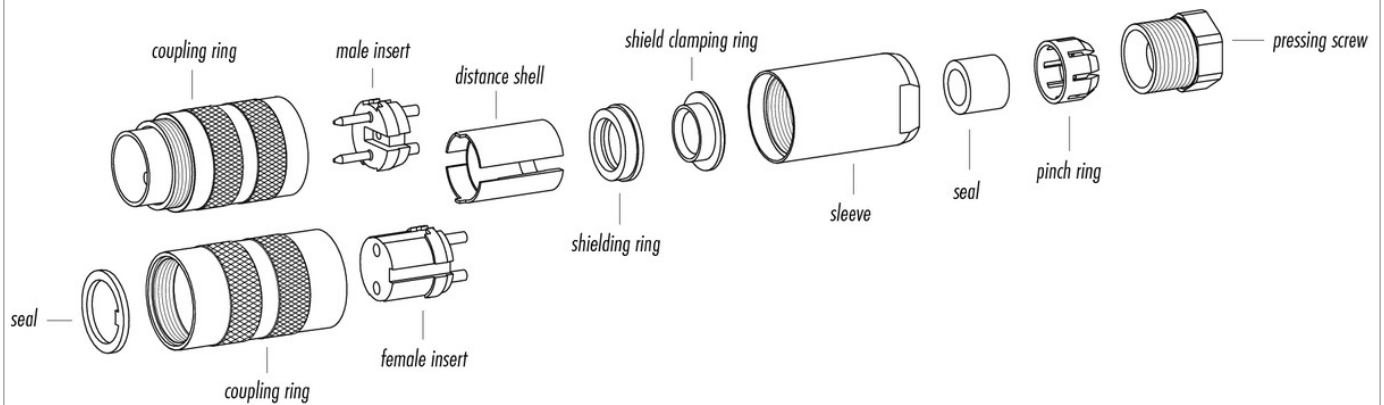

Assembly instructions / Panel cut-out

**Gerade Version**

(Ausführung mit Schirmklemmung)

1. Druckschraube, Klemmkorb, Dichtung, Distanzhülse und ersten Schirmklemmring auffädeln.
2. Litzen abisolieren, Schirm aufweiten und zweiten Schirmklemmring auffädeln.
3. Litzen anlöten, Distanzhülse montieren, die beiden Klemmringe mit dem Schirm zusammenschieben und überstehenden Schirm abschneiden.
4. Übrige Teile gemäß Darstellung montieren.

**Straight version**

(Version with shield clamping ring)

1. Bead pressing screw, pinch ring, seal, distance shell and first shield clamping ring on cable.
2. Strip wires, widen shield and bead second shield clamping ring.
3. Solder wires, snap distance shell, push the two shield clamping rings together and cutt off projecting shielding braid.
4. Assemble remaining parts according to picture.

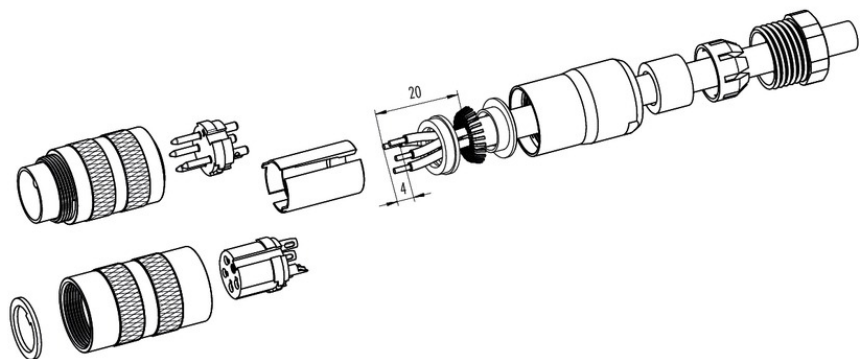

Product description	<b>Polzahl: 7 DIN, Kabeldose mit Schirmring, schirmbar, Kabeldurchlass 6 - 8 mm, versilberte Kontakte, mit UL-Zulassung</b>
Area	<b>M16 IP67 Series 423</b>
Order number	<b>99 5682 15 07</b>

## Sicherheitshinweise

2. The connectors are designed for use in plant, control system and electrical equipment. The end user is responsible for checking whether the connectors are suitable for use in other applications.
6. Connectors with degree of protection IP 67 and IP 68 are not suitable for use under water. When used outdoors, the connectors must be separately protected against corrosion. For further information about IP degrees of protection refer to 'Technical support' in the Download Centre.
8. To lock the cable connector to the equipment connector, the threaded ring is tightened until it is 'finger-tight' (approx. 50 cNm).