

Picture coming soon

FEATURES:

- Wide Input range 2:1
- High Efficiency up to 93%
- Remote On/Off Control
- Trim Adjustment
- Input to Output Isolation of 1500VDC
- Input Over Voltage and Under Voltage Lockout
- Output OVP, OCP & SCP
- Operating Temperature -40 to +85°C

Models
Single output



Model	Input Voltage (V)	Output Voltage (V)	Output Current max (A)	No load Input Current (mA)	Max Capacitive Load(μF)	Efficiency (%)
AM50E-2403S-NZ	18-36	3.3	10	70	27000	91
AM50E-2405S-NZ	18-36	5	10	70	18900	93
AM50E-2412S-NZ	18-36	12	4.167	70	3700	93
AM50E-2415S-NZ	18-36	15	3.333	70	2000	93
AM50E-2424S-NZ	18-36	24	2.083	70	1000	93
AM50E-4803S-NZ	36-75	3.3	10	50	27000	91
AM50E-4805S-NZ	36-75	5	10	50	18900	93
AM50E-4812S-NZ	36-75	12	4.167	50	3700	93
AM50E-4815S-NZ	36-75	15	3.333	50	2000	93
AM50E-4824S-NZ	36-75	24	2.083	50	1000	93

Add suffix "-K" for optional heatsink

NOTE: All specifications in this datasheet are measured at an ambient temperature of 25°C, humidity<75%, nominal input voltage and at rated output load unless otherwise specified.

Input Specifications

Parameters	Nominal	Typical	Maximum	Units
Voltage range	24	18-36		VDC
	48	36-75		
Filter	π(Pi) Network			
Start up time		10		ms
Absolute Maximum Rating	24		-0.7 ~ 50	VDC
	48		-0.7 ~ 100	
Peak Input Voltage time			1	s
On/Off control*	ON – open or TTL high (3 - 12VDC) ; OFF – connected to GND or TTL low (0 - 1.2VDC)			
Input Current	24	2.24		A
	48	1.12		
Over Voltage Lockout	24		40	VDC
	48		81	
Under Voltage Lockout	24		16	VDC
	48		32	
Input reflected current	24	40		mA
	48	30		

*The voltage on the On/Off Control pin is relative to input Ground.

Isolation Specifications

Parameters	Conditions	Typical	Rated	Units
Tested I/O voltage	1 min, ≤1mA	1500	1500	VDC
Resistance	Isolation 500VDC	>1000		MOhm
Capacitance	100kHz, 0.1V	2000		pF

Output Specifications

Parameters	Conditions	Typical	Maximum	Units
Voltage accuracy		±2		%
Over voltage protection*	3.3V output		3.9	VDC
	5V output		6.2	
	12V output		15	
	15V output		18	
	24V output		30	
Over current protection		135		%
Short Circuit protection	Hiccup, continuous			
Short circuit restart	Auto-restart			
Line voltage regulation	LL-HL	±0.3		% of Vin
Load voltage regulation	10-100% load	±0.5		%
Temperature coefficient		±0.02		%/°C
Ripple & Noise	20MHz Bandwidth	120		mV p-p
Voltage adjustment range		±10		%
Transient recovery time	25% load step	400		µS
Transient recovery deviation	25% load step	±4		%

*Restart needed to function properly

General Specifications

Parameters	Conditions	Typical	Maximum	Units
Switching frequency	100% load	300		KHz
Operating temperature	See derating curve	-40 to +85		°C
Storage temperature		-55 to +125		°C
Maximum case temperature			105	°C
Cooling	Free Air Convection			
Humidity			95	% RH
Case material	Aluminum alloy			
Weight	Without heatsink	35		g
	With heatsink	43		
Dimensions (L x W x H)	Without heatsink	2 x 1 x 0.46 inches	50.8 x 25.4 x 11.8 mm	
	With heatsink	2 x 1 x 0.64 inches	50.8 x 25.4 x 16.3 mm	
MTBF	>1 000 000 hrs (MIL-HDBK-217 F at +25 °C)			
Maximum soldering temperature	10sec, 1.5mm from case		300	°C

Environmental Specifications

Parameters		
Vibration	Test mode	10-55Hz
	Acceleration	10G, 30min one cycle, every axis tested
	Converter operation	Before and after test, body mounted (on chassis)

Safety Specifications

Parameters		
Standards	Information Technology Equipment	EN55022 Class B, with the recommended circuit below, EN55024
	Electrostatic Discharge Immunity	IEC 61000-4-2, Contact ±4KV, Criteria B
	RF, Electromagnetic Field Immunity	IEC 61000-4-3, 10V/m, Criteria A
	Electrical Fast Transient / Burst Immunity	IEC 61000-4-4, ±2KV, Criteria B, with the recommended circuit below
	Surge Immunity	IEC 61000-4-5, ±2KV, Criteria B, with the recommended circuit below
	RF, Conducted Disturbance Immunity	IEC 61000-4-6, 3 Vrms, Criteria A

Pin Out Specifications

Pin	Single
1	+V Input
2	-V Input
3	On/Off Control
4	+V Output
5	-V Output
6	Trim

Dimensions

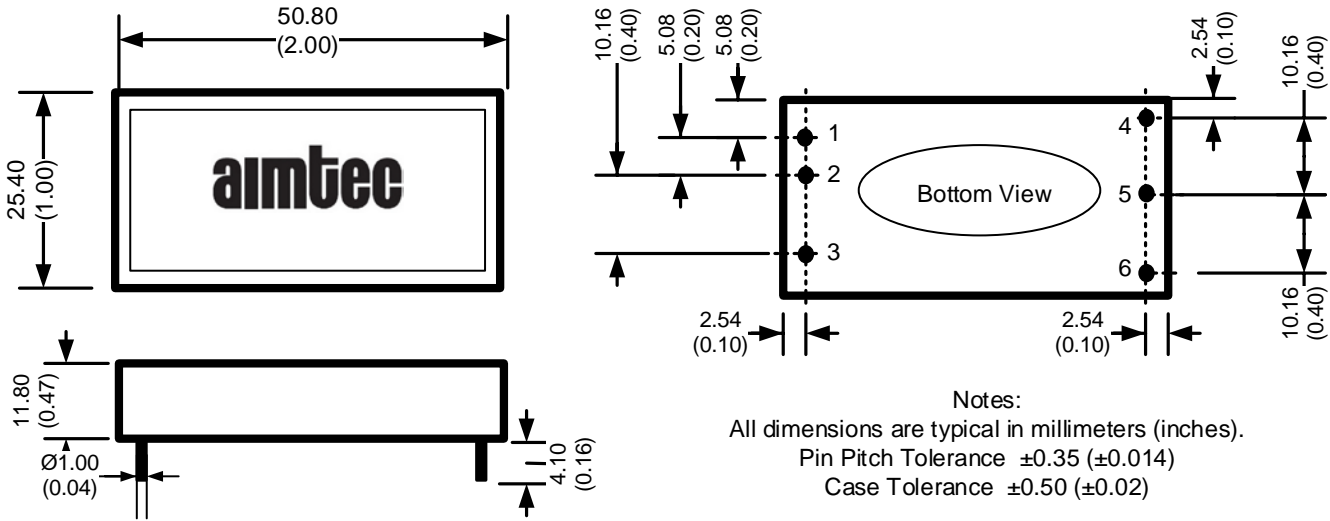

Trimming

Output voltage can be externally trimmed by utilizing the methods as shown below

Fixed Resistor

Variable Potentiometer

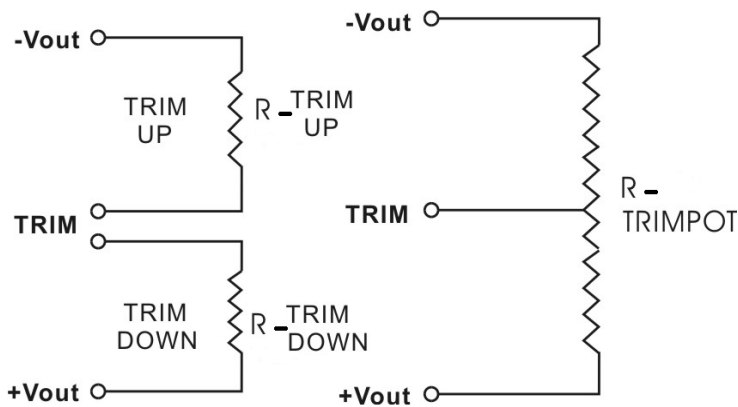

Leave open if not used.

AM50E-xx03S-NZ

Trim down %	1	2	3	4	5	6	7	8	9	10
Vout (VDC)	3.27	3.23	3.20	3.17	3.14	3.10	3.07	3.04	3.00	2.97
Rt down (KΩ)	236.27	106.095	71.347	51.633	38.931	27.676	21.71	17.076	12.299	9.457
Trim up %	1	2	3	4	5	6	7	8	9	10
Vout (VDC)	3.33	3.37	3.40	3.43	3.47	3.50	3.53	3.56	3.60	3.63
Rt up (KΩ)	263.512	81.826	50.017	33.939	21.804	16.033	11.826	8.624	5.38	3.447

AM50E-xx05S-NZ

Trim down %	1	2	3	4	5	6	7	8	9	10
Vout (VDC)	4.95	4.9	4.85	4.8	4.75	4.7	4.65	4.6	4.55	4.5
Rt down (KΩ)	128.53	56.78	32.863	20.905	13.73	8.947	5.53	2.968	0.974	-0.62
Trim up %	1	2	3	4	5	6	7	8	9	10
Vout (VDC)	5.05	5.1	5.15	5.2	5.25	5.3	5.35	5.4	5.45	5.5
Rt up (KΩ)	131.399	59.65	35.733	23.775	16.6	11.817	8.4	5.838	3.844	2.25

AM50E-xx12S-NZ

Trim down %	1	2	3	4	5	6	7	8	9	10
Vout (VDC)	11.88	11.76	11.64	11.52	11.4	11.28	11.16	11.04	10.92	10.8
Rt down (KΩ)	489.091	294.452	205.527	154.585	121.573	98.442	81.332	68.164	57.716	49.223
Trim up %	1	2	3	4	5	6	7	8	9	10
Vout (VDC)	12.12	12.24	12.36	12.48	12.6	12.72	12.84	12.96	13.08	13.2
Rt up (KΩ)	699.444	151.922	76.879	47.075	31.077	21.095	14.274	9.317	5.552	2.595

AM50E-xx15S-NZ

Trim down %	1	2	3	4	5	6	7	8	9	10
Vout (VDC)	14.85	14.7	14.55	14.4	14.25	14.1	13.95	13.8	13.65	13.5
Rt down (KΩ)	1213	588	379.667	275.5	213	171.333	141.571	119.25	101.889	88
Trim up %	1	2	3	4	5	6	7	8	9	10
Vout (VDC)	15.15	15.3	15.45	15.6	15.75	15.9	16.05	16.2	16.35	16.5
Rt up (KΩ)	228	103.001	61.333	40.5	28	19.667	13.714	9.25	5.778	3

AM50E-xx24S-NZ

Trim down %	1	2	3	4	5	6	7	8	9	10
Vout (VDC)	23.76	23.52	23.28	23.04	22.8	22.56	22.32	22.08	21.84	21.6
Rt down (KΩ)	1038.048	638.015	455.256	350.553	282.702	235.159	199.993	172.928	151.453	133.999
Trim up %	1	2	3	4	5	6	7	8	9	10
Vout (VDC)	24.24	24.48	24.72	24.96	25.2	25.44	25.68	25.92	26.16	26.4
Rt up (KΩ)	640.98	143.116	74.892	47.797	33.252	24.178	17.977	13.47	10.047	7.359

Derating

For 3.3 & 5V output models:

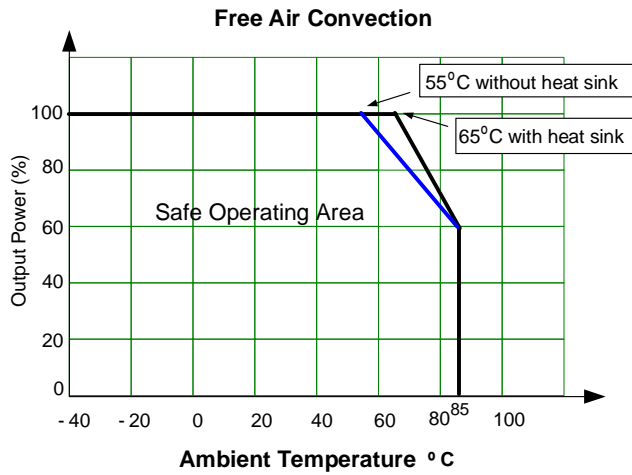

For 12, 15 & 24V output models

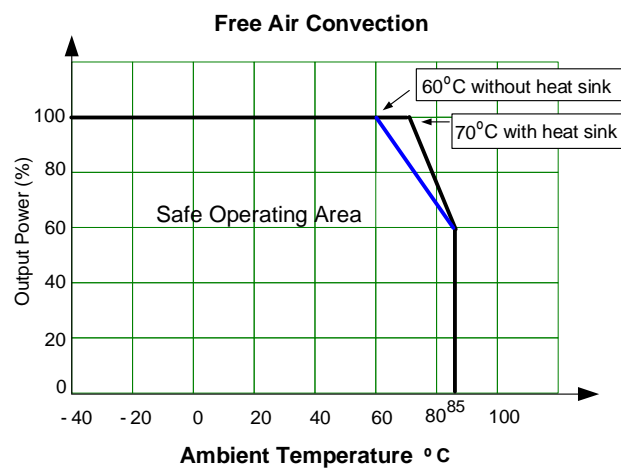

EMC recommended circuit

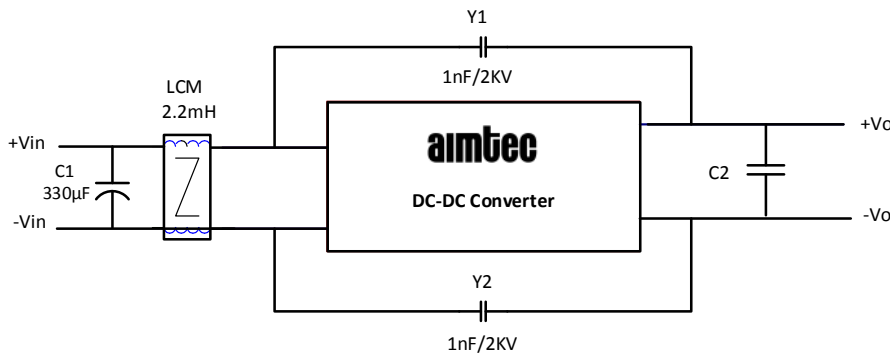

Vout	C2 (µF)
3.3 & 5V	220
12 & 15V	100
24V	47

NOTE: 1. Datasheets are updated as needed and as such, specifications are subject to change without notice. Once printed or downloaded, datasheets are no longer controlled by Aimtec; refer to www.aimtec.com for the most current product specifications. 2. Product labels shown, including safety agency certifications on labels, may vary based on the date manufactured. 3. Mechanical drawings and specifications are for reference only. 4. All specifications are measured at an ambient temperature of 25°C, humidity<75%, nominal input voltage and at rated output load unless otherwise specified. 5. Aimtec may not have conducted destructive testing or chemical analysis on all internal components and chemicals at the time of publishing this document. CAS numbers and other limited information are considered proprietary and may not be available for release. 6. This product is not designed for use in critical life support systems, equipment used in hazardous environments, nuclear control systems or other such applications which necessitate specific safety and regulatory standards other the ones listed in this datasheet. 7. Warranty is in accordance with Aimtec's standard Terms of Sale available at www.aimtec.com.