

# BGSX22G2A10

## DPDT Antenna Cross Switch

### Features

- RF CMOS DPDT antenna cross switch with power handling capability of up to 36.5 dBm
- Suitable for multi-mode LTE and WCDMA multi antenna applications
- Ultra-low insertion loss and harmonics generation
- 0.1 to 6.0 GHz coverage
- High port-to-port-isolation
- No decoupling capacitors required if no DC applied on RF lines
- General Purpose Input-Output (GPIO) Interface
- Small form factor 1.15mm x 1.55mm
- No power supply blocking required
- High EMI robustness
- RoHS and WEEE compliant package

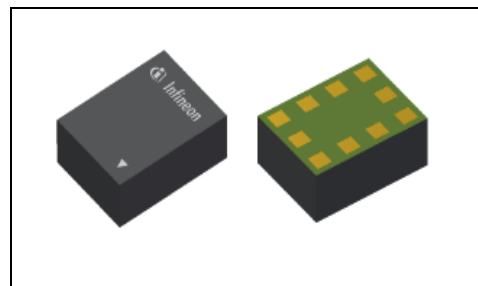

### Description

The BGSX22G2A10 RF MOS switch is specifically designed for LTE and WCDMA triple antenna applications. This DPDT offers low insertion loss and low harmonic generation paired with high isolation between RF ports. The switch is controlled via a GPIO interface. The on-chip controller allows power-supply voltages from 2.3V to 3.4V. The switch features direct-connect-to-battery functionality and DC-free RF ports. Unlike GaAs technology, external DC blocking capacitors at the RF Ports are only required if DC voltage is applied externally. The BGSX22G2A10 RF Switch is manufactured in Infineon's patented MOS technology, offering the performance of GaAs with the economy and integration of conventional CMOS including the inherent higher ESD robustness. The device has a very small size of only 1.15 x 1.55mm<sup>2</sup> and a maximum thickness of 0.6mm.

Block diagram and ordering information

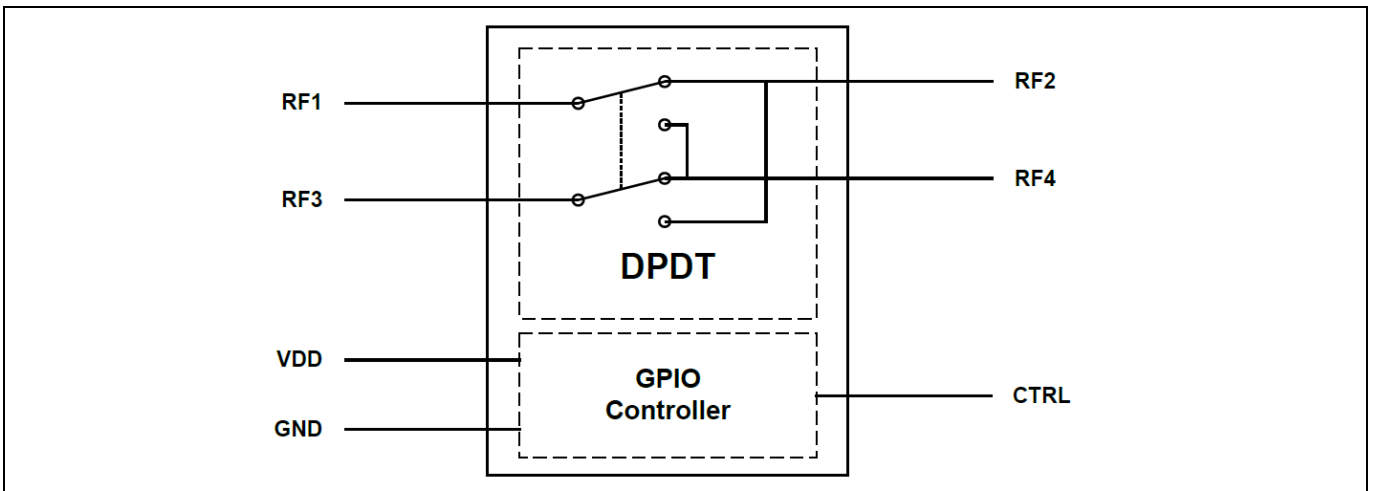

Figure 1 BGSX22G2A10 Block diagram

Table 1 Ordering Information

Type	Package	Marking
BGSX22G2A10	ATSLP-10-2	XB



WEEE Compliant Package



Halogen-Free PB Free



RoHS

Trademarks

All referenced product or service names and trademarks are the property of their respective owners.

Edition 2017-07-12

Published by

Infineon Technologies AG

81726 München, Germany

© 2017 Infineon Technologies AG.

All Rights Reserved.

Do you have a question about this document?

Email: [erratum@infineon.com](mailto:erratum@infineon.com)

Document reference

ifx1

IMPORTANT NOTICE

The information given in this document shall in no event be regarded as a guarantee of conditions or characteristics ("Beschaffenheitsgarantie").

With respect to any examples, hints or any typical values stated herein and/or any information regarding the application of the product, Infineon Technologies hereby disclaims any and all warranties and liabilities of any kind, including without limitation warranties of non-infringement of intellectual property rights of any third party.

In addition, any information given in this document is subject to customer's compliance with its obligations stated in this document and any applicable legal requirements, norms and standards concerning customer's products and any use of the product of Infineon Technologies in customer's applications.

The data contained in this document is exclusively intended for technically trained staff. It is the responsibility of customer's technical departments to evaluate the suitability of the product for the intended application and the completeness of the product information given in this document with respect to such application.

For further information on the product, technology, delivery terms and conditions and prices please contact your nearest Infineon Technologies office ([www.infineon.com](http://www.infineon.com)).

WARNINGS

Due to technical requirements products may contain dangerous substances. For information on the types in question please contact your nearest Infineon Technologies office.

Except as otherwise explicitly approved by Infineon Technologies in a written document signed by authorized representatives of Infineon Technologies, Infineon Technologies' products may not be used in any applications where a failure of the product or any consequences of the use thereof can reasonably be expected to result in personal injury.

## X-ON Electronics

Largest Supplier of Electrical and Electronic Components

*Click to view similar products for [Analogue Switch ICs category](#):*

*Click to view products by [Infineon manufacturer](#):*

Other Similar products are found below :

[FSA3051TMX](#) [NLVAS4599DTT1G](#) [MAX4992EVB+T](#) [MAX4684ETB+T](#) [BCM6522IPBG](#) [BCM65300IFSBG](#) [MAX14764ETA+T](#)  
[TMUX1113RSVR](#) [TMUX1112RSVR](#) [ADG1436TRUZ-EP](#) [BL4684C](#) [PE423422A](#) [PE42359SCAA](#) [PE42540F](#) [RS550YUCM12](#)  
[ADGS1414DBCCZ](#) [ADG658YRUZ-REEL7](#) [RS2117YUTQK10](#) [RS2118YUTQK10](#) [RS2227XUTQK10](#) [SP2526A-1EN-L/TR](#) [FSA4157P6X](#)  
[BA7603F-E2](#) [MAX4702EUE+](#) [MAX4617CUE+](#) [MAX4599EUT+T](#) [MAX4066ESD+](#) [MAX4052ACSE+](#) [MAX396CAI+](#) [MAX391CPE+](#)  
[MAX4730EXT+T](#) [MAX314CPE+](#) [MAX4051AEEE+](#) [BU4066BCFV-E2](#) [MAX313CPE+](#) [BU4S66G2-TR](#) [TS3A4751PWR](#)  
[NCN1154MUTAG](#) [DG444DY-E3](#) [NLAS4157DFT2G](#) [NLAS4599DFT2G](#) [NLAS7242MUTBG](#) [NLASB3157DFT2G](#) [NLAST4599DFT2G](#)  
[NLAST4599DTT1G](#) [DG403DY-T1-E3](#) [MAX4714EXTT](#) [MAX392CPE](#) [BGSX22G2A10E6327XTSA1](#) [ADG1611BRUZ-REEL7](#)