

REVISION RECORD

REV	ECN	DESCRIPTION	DRFT	DATE

仅供参考图
 签字: *董贵化*
 日期: 2015.09.28

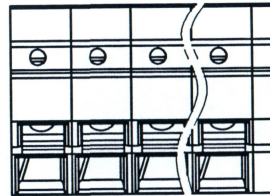

NOTES1:

UL Standard

- 1.Rated Voltage/Current : 300V / 10A
- 2.Withstanding Voltage : AC1600V/1Min.
- 3.Wire Range : 26~16AWG

IEC Standard

1. Pollution Degree	2	2	3
	Overvoltage Category	II	III
Rate Impulse Voltage(kV)	2.5KV	2.5KV	2.5KV
Rate Voltage(V)	320V	160V	160V
Rate Current(A)	9A		

2.Wire Range : 0.2~1.5mm²

NOTES2:

- 1.Dimension shall be interpreted per ASME Y14.5-2009
- 2.Pitch : 3.81mm, Poles : N=1~XXP
- 3.Stripping length : 10mm
- 4.Operating temperature: -40°C~+105°C
- 5.Undimensioned Tolerances:

Pitch Range In mm	Nominal Dimension Range In mm						0.1/10	
	Over 6 TO 10	Over 10 TO 24	Over 30 TO 60	Over 60 TO 100	Over 100 TO 150	Over 150		
±0.15	±0.20	±0.30	±0.30	±0.50	±0.70	±1.00	±1.30	±2*

6.RoHS Compliance

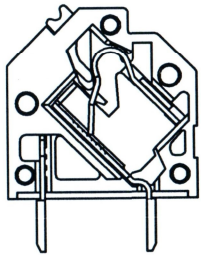
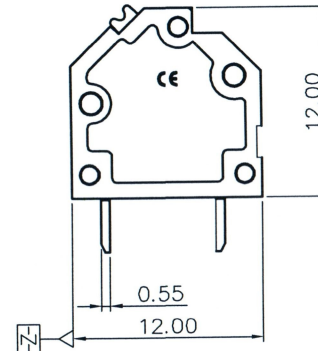
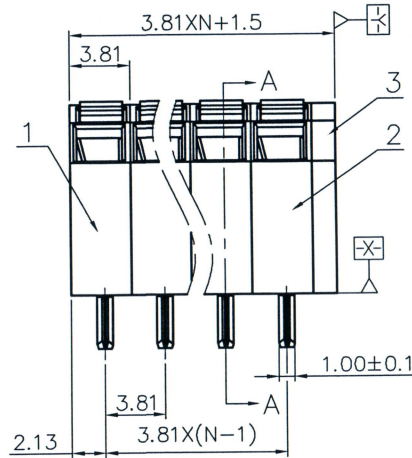
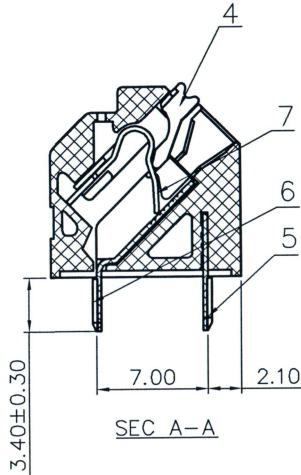

W/O COVER VIEW

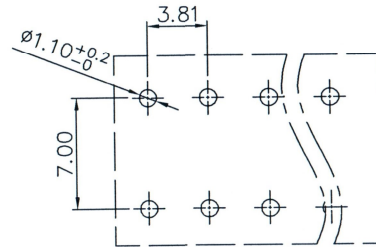

PCB LAYOUT

ITEM	NAME OF PART	MATERIAL	NOTES
7	Spring	Stainless Steel	
6	Back Pin Header	COPPER ALLOY	Sn plated
5	Front Pin Header	COPPER ALLOY	Sn plated
4	Button	PA66	UL94V-0
3	Cover	PA66	UL94V-0
2	Housing	PA66	UL94V-0
1	Side Housing	PA66	UL94V-0

DETACHED LISTS	PART NO.: /	宁波高松电子有限公司 DEGSON ® NINGBO DEGSON ELECTRICAL CO., LTD		
	APPD: <i>slm 09/28/15</i>	NAME: DG246-3.81-XXP-1Y-00A(H)		
	CHKD: <i>perry 9/28-15</i>	TITLE: CUSTOMER DRAWING		REV: D0-1
	DRFT: MEK 10/20/14	DRAWING NO.: DG246-3.81-C01	SHEET: 1/1	SCALE: 1:1
THIRD ANGLE PROJECTION		MM (INCH)	DO NOT SCALE DRAWING	SCALE: 1:1