

LPC2148 USB QuickStart Board User's Guide

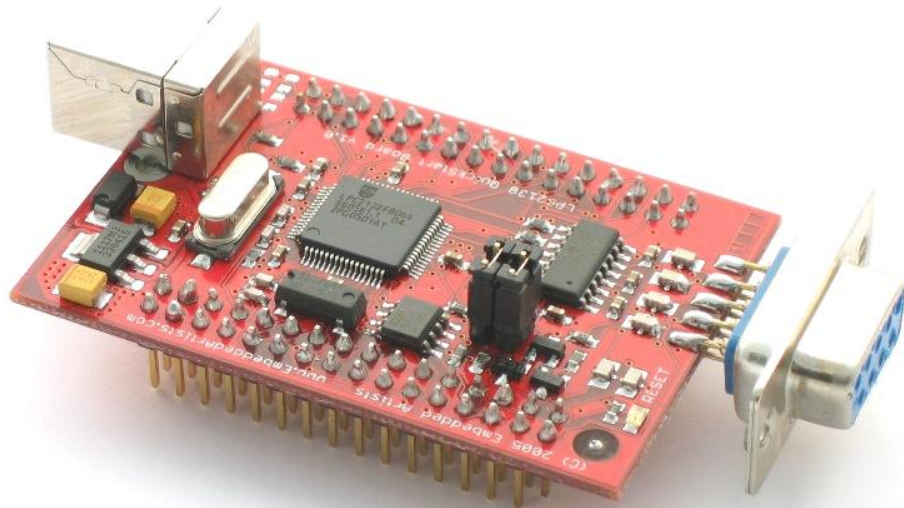

*Get Up-and-Running Quickly and
Start Developing on Day 1...*

Embedded Artists AB

Davidshallsgatan 16
SE-211 45 Malmö
Sweden

info@EmbeddedArtists.com
<http://www.EmbeddedArtists.com>

Copyright 2005-2012 © Embedded Artists AB. All rights reserved.

No part of this publication may be reproduced, transmitted, transcribed, stored in a retrieval system, or translated into any language or computer language, in any form or by any means, electronic, mechanical, magnetic, optical, chemical, manual or otherwise, without the prior written permission of Embedded Artists AB.

Disclaimer

Embedded Artists AB makes no representation or warranties with respect to the contents hereof and specifically disclaim any implied warranties or merchantability or fitness for any particular purpose. Information in this publication is subject to change without notice and does not represent a commitment on the part of Embedded Artists AB.

Feedback

We appreciate any feedback you may have for improvements on this document. Please send your comments to support@EmbeddedArtists.com.

Trademarks

All brand and product names mentioned herein are trademarks, services marks, registered trademarks, or registered service marks of their respective owners and should be treated as such.

Table of Contents

1	Document Revision History	4
2	Introduction	5
2.1	Contents	5
2.2	Features	5
2.3	ESD Precaution	6
2.4	CE Assessment	6
2.5	Other Products from Embedded Artists	6
2.5.1	Design and Production Services	7
2.5.2	OEM / Education / QuickStart Boards and Kits	7
3	Board Design	8
3.1	Mechanical Dimensions	10
3.2	Examples	11
3.2.1	JTAG	11
3.2.2	Reset	12
3.2.3	I ² C	13
3.2.4	SPI	14
3.2.5	LEDs	15
4	Getting Started	16
4.1	Test program	16
4.2	Program Development	16
5	Further Information	17

1 Document Revision History

<i>Revision</i>	<i>Date</i>	<i>Description</i>
v1.2	2012-01-13	Added this revision history table. Added note about ESD precaution and CE marking. Removed schematic from document.

2 Introduction

Thank you for buying Embedded Artists' *LPC2148 USB QuickStart Board* based on NXP's ARM7TDMI LPC2148 microcontroller.

This document is a User's Guide that describes the *LPC2148 USB QuickStart Board* design along with the accompanying software and program development tools. The document contains information on how to use and integrate the board in your own designs, including electrical and mechanical information.

2.1 Contents

The box received when ordering the *LPC2148 USB QuickStart Board* contains the following:

- The *LPC2148 USB QuickStart Board*.

In addition, the following is needed in order to start developing applications with the *LPC2148 USB QuickStart Board*:

- A DC power supply, 5-10 volt, capable of providing at least 150 mA (more if external circuits need power from the 3.3 volt supply). The *LPC2148 USB QuickStart Board* does not contain reverse polarity protection. Consult the schematic and the LD1117 datasheet for details about the voltage regulator.
- A serial extension cable, DB9-male to DB9-female (DB9M-DM9F), for connecting the *LPC2148 USB QuickStart Board* to a PC.
- A USB cable of type: B-to-A, both male connectors.
- An optional *Prototype QuickStart Board* to quickly get up-and-running with the hardware. See Embedded Artists' homepage for more information about the *Prototype QuickStart Board*.
- An optional JTAG interface, for program development debugging.

2.2 Features

Embedded Artists' *LPC2148 USB QuickStart Board* lets you get up-and-running quickly with NXP's ARM7TDMI LPC2148 microcontroller. The small form factor board offers many unique features that ease your development.

- NXP ARM7TDMI LPC2148 microcontroller with 512 KByte program Flash and 32+8 KByte SRAM
- All LPC2148 I/O pins are available on connectors
- 12.0000 MHz crystal for maximum execution speed and standard serial bit rates
 - Phase-locked loop (PLL) multiplies frequency with five; $5 \times 12 \text{ MHz} = 60 \text{ MHz}$
- 32.768kHz RTC crystal
- ESD/EMI protected RS232 channel with DSUB-9 connector
 - Both UART #0 and #1 connected
 - Signals available on expansion connector
- 2 Kbit I²C E²PROM for storing non-volatile parameters
- Onboard low-dropout voltage and reset generation.
 - Generates +3.3V from a single +5V supply
 - +3.3V available for external circuits, up to 300 mA

- Power supply: 5-10 VDC, at least 150 mA, or via USB connector
- Simple and automatic program download (ISP) via RS232 channel
 - Circuit that automatically controls the bootloader from RS232 channel
- Dimensions: 59 x 39.5 mm
 - Small form factor for easy integration
 - Dual 2x16 pins I/O connectors
 - Four layer PCB (FR-4 material) for best noise immunity

2.3 ESD Precaution

Please note that the *LPC2148 USB QuickStart Board* come without any case/box and all components are exposed for finger touches – and therefore extra attention must be paid to ESD (electrostatic discharge) precaution.

Make it a habit always to first touch the metal surface of the USB connector for a few seconds with both hands before touching any other parts of the board. That way, you will have the same potential as the board and therefore minimize the risk for ESD.



Note that Embedded Artists does not replace boards that have been damaged by ESD.

2.4 CE Assessment

The *LPC2148 USB QuickStart Board* is CE marked. See separate *CE Declaration of Conformity* document.

The *LPC2148 USB QuickStart Board* is a class B product.

EMC emission test has been performed on the *LPC2148 USB QuickStart Board*. The USB interface has been in use and also powered the device during the test. General expansion connectors where internal signals are made available have been left unconnected. Connecting other devices to the product via the general expansion connectors may alter EMC emission. It is the user's responsibility to make sure EMC emission limits are not exceeded when connecting other devices to the general expansion connectors of the *LPC2148 USB QuickStart Board*.

Due to the nature of the *LPC2148 USB QuickStart Board* – an evaluation board not for integration into an end-product – fast transient immunity tests and conducted radio-frequency immunity tests have not been executed. Externally connected cables are assumed to be less than 3 meters. The general expansion connectors where internal signals are made available do not have any other ESD protection than from the chip themselves. Observe ESD precaution.

Note that the *LPC2148 USB QuickStart Board* can also be considered to be a component if integrated into another product. The CE mark on the *LPC2148 USB QuickStart Board* cannot be extended to include the new (user created) product. It is the user's responsibility to make sure EMC emission limits are not exceeded and CE mark the final product.

2.5 Other Products from Embedded Artists

Embedded Artists have a broad range of LPC1000/2000/3000/4000 based boards that are very low cost and developed for prototyping / development as well as for OEM applications. Modifications for OEM applications can be done easily, even for modest production volumes. Contact Embedded Artists for further information about design and production services.

2.5.1 Design and Production Services

Embedded Artists provide design services for custom designs, either completely new or modification to existing boards. Specific peripherals and I/O can be added easily to different designs, for example, communication interfaces, specific analog or digital I/O, and power supplies. Embedded Artists has a broad, and long, experience in designing industrial electronics in general and with NXP's LPC1000/2000/3000/4000 microcontroller families in specific. Our competence also includes wireless and wired communication for embedded systems. For example IEEE802.11b/g (WLAN), Bluetooth™, ZigBee™, ISM RF, Ethernet, CAN, RS485, and Fieldbuses.

2.5.2 OEM / Education / QuickStart Boards and Kits

Visit Embedded Artists' home page, www.EmbeddedArtists.com, for information about other *OEM / Education / QuickStart* boards / kits or contact your local distributor.

3 Board Design

This chapter contains detailed information about the electrical and mechanical design of the *LPC2148 USB QuickStart Board*. The schematic can be downloaded in pdf format from the support page, and is recommended to have printed out while reading this chapter. A number of example circuits are also presented that will lower the threshold of start developing applications with the board.

Besides the LPC2148 microcontroller from NXP, the board contains an USB interface, a 3.3V low-dropout voltage regulator, a 2 Kbit I²C E²PROM with reset generation, and an ESD/EMI protected RS232 serial channel. Both UART channels on the processor can use the RS232 interface. Only UART #0 is however connected to the DSUB-9 connector. A red LED is connected to the reset signal and lights when reset is active, i.e., the signal is low. Power can either be supplied via the expansion connector or via the USB connector. Powering via the USB connector should only be used if the external power need is limited to 100-150 mA. If the board is powered from the USB interface jumper J6 must be inserted (see schematic above). Also note that it is not allowed to both power the board from the USB interface and from an external source (+5V DC). The USB interface (typically on the PC-side) can get damaged in that case. The USB interface supports the Soft Connect functionality and voltage sense (see LPC2148 User's Manual for more information about these functions).

The microcontroller crystal frequency is 12.0000 MHz. This frequency has been selected in order to allow maximum execution speed ($5 \times 12 \text{ MHz} = 60 \text{ MHz}$, which is the maximum frequency). The on-chip UART peripheral includes a fractional baud rate generator that allow standard baud rates to be generated from the 60 MHz base clock. The USB clock is also generated from the 60 MHz clock without any problems.

The crystal frequency can be changed to any desired value for OEM orders, provided that the conditions in the LPC2148 datasheet are met. Current requirements are (but consult the most current datasheet for latest details):

- 1-30 MHz if the on-chip phase-locked loop (PLL) is not used, or
- 10-25 MHz if the PLL is to be used.

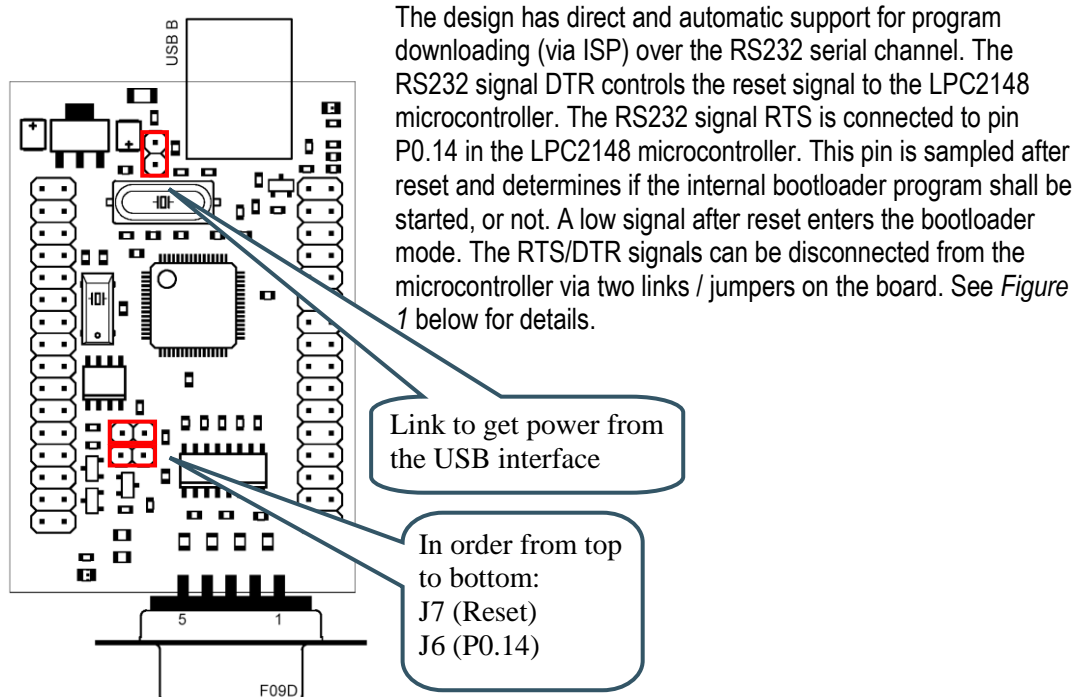

Figure 1 - LPC2148 QuickStart Board ISP Jumpers

The board interface connectors are placed in two 2x16 pin rows along the board edges. They are 1200 mil (30.48 mm) apart. *Figure 2* below illustrates the two row connectors and their signals.

Note that P0.26 and P0.27 are the USB signals and should normally be left unconnected, unless and external USB connector is implemented. Sometimes P0.23 is also used by the application and should also in this case be left unconnected.

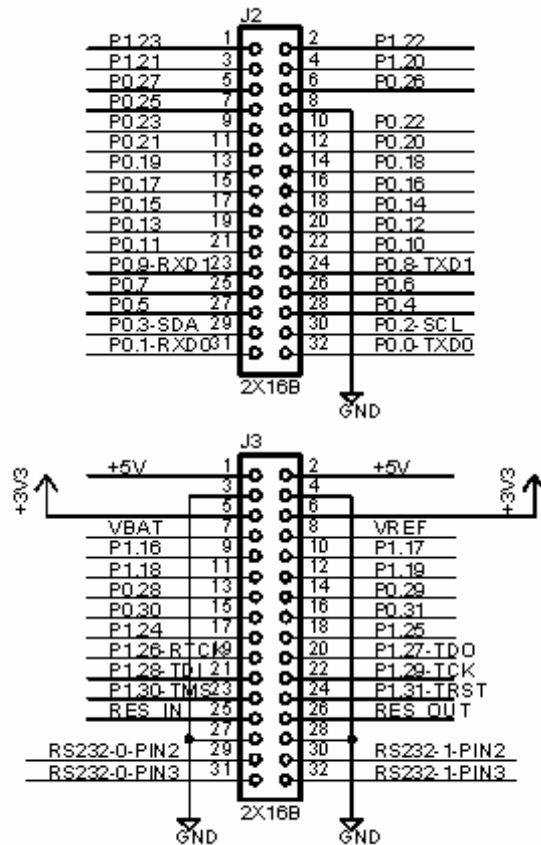

Figure 2 - LPC2148 QuickStart Board Interface Connectors

3.1 Mechanical Dimensions

Figure 3 below contains a drawing of the board that includes mechanical measures.

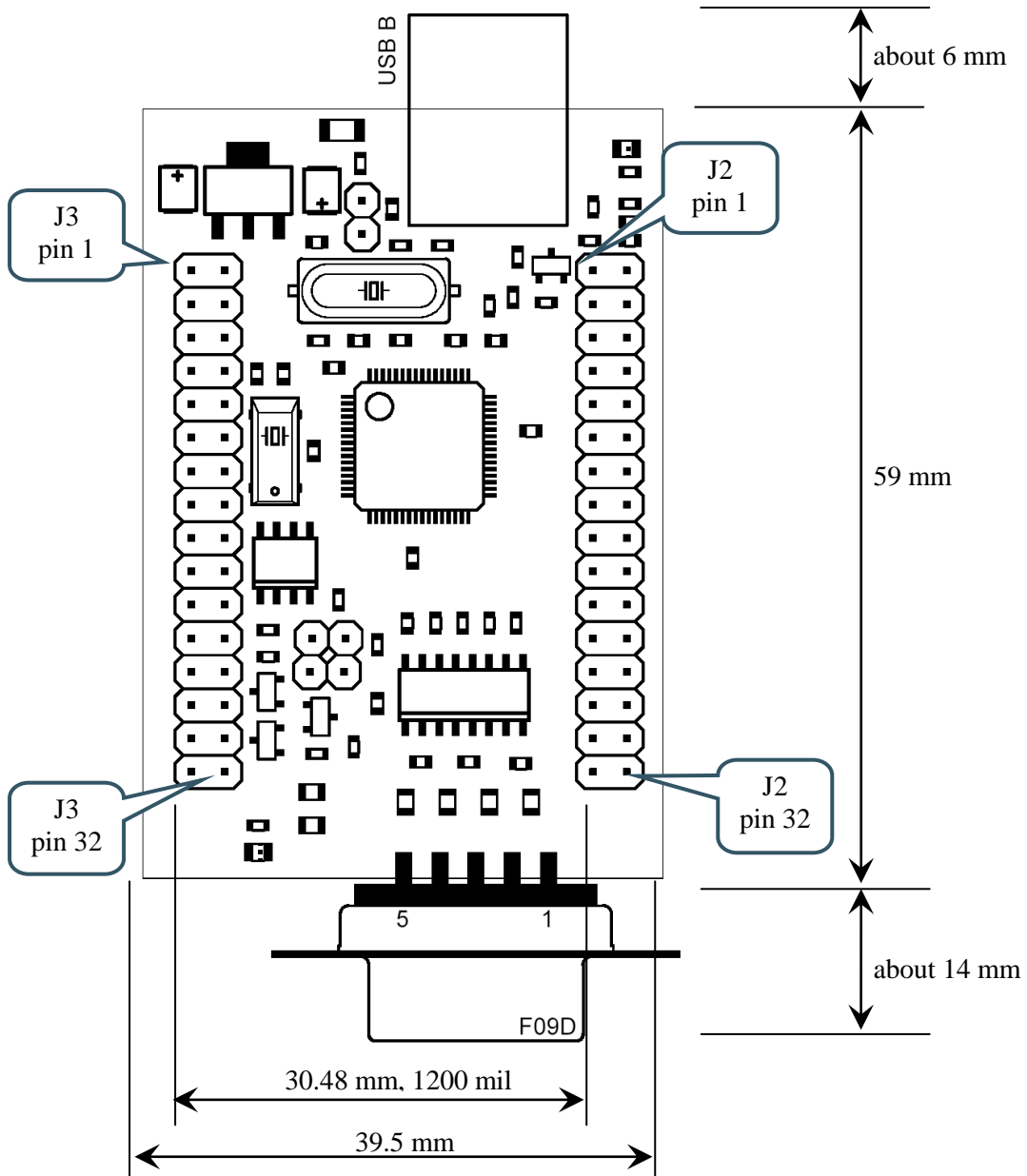

Figure 3 - LPC2148 QuickStart Board Mechanical Dimensions

3.2 Examples

This section contains a few sample / illustrative circuit examples that will help you to quickly get up-and-running with the board interface design. Detailed information about the on-chip peripheral units can be found in the LPC2148 User's Manual.

3.2.1 JTAG

The LPC2148 microcontroller contains a JTAG interface that can be used for debug purposes during program development. The circuit in *Figure 4* below works for many JTAG interfaces on the market, including CrossConnect from Rowley Associates, J-link from Segger, Ulink from Keil, and Wiggler from MacRaigor.

The signal RTCK on the LPC2148 microcontroller is sampled during reset. Jumper J5 drives the signal low. If the signal is found low, the JTAG interface is enabled. Pin P1.26-P1.31 then changes from being general I/O pins to dedicated JTAG pins.

Note that many Wiggler JTAG interfaces do not work with a processor crystal frequency above about 10 MHz. If this is the case, the crystal frequency can be changed by desoldering the 12.0000 MHz crystal and replace it with another suitable one.

LPC2148 QuickStart Board

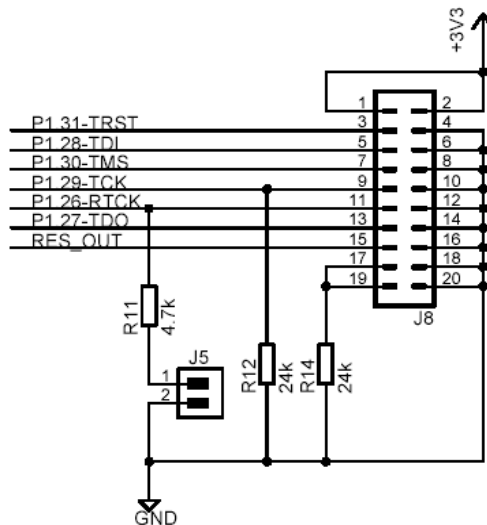
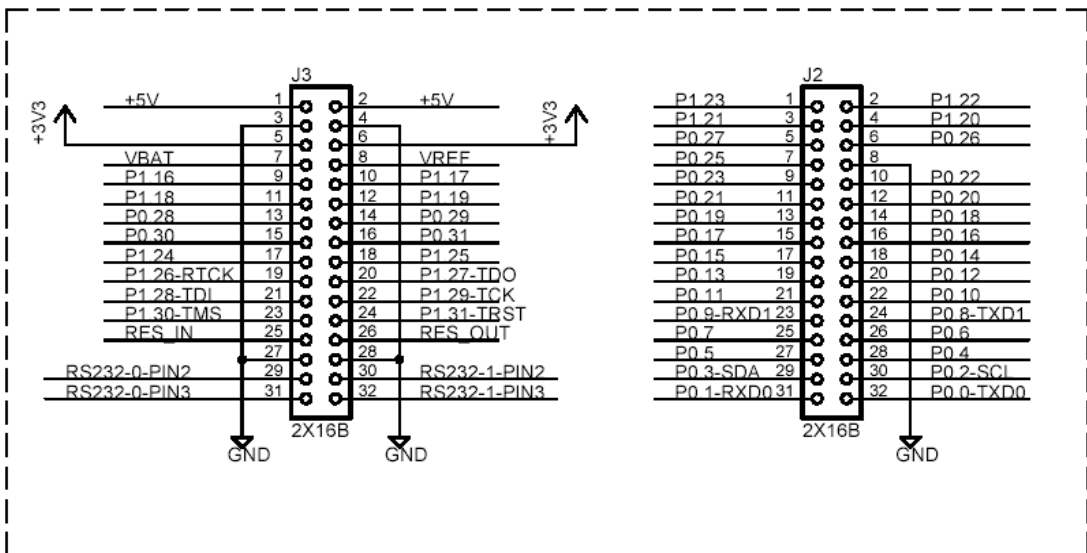

Figure 4 – Example JTAG Interface

3.2.2 Reset

The on-board I2C E2PROM (CAT1025) also contains a reset generator. The reset signal will be held active (i.e., low) until the supply voltages, +3.3V, is within margins. The reset duration is typically 200 mS (consult the CAT1025 datasheet for exact details). The output reset signal is an open-collector / open-drain output. An external reset source can also control the reset generator. *Figure 5* below illustrate how an external push-button can generate a reset. Note that an external driver should be an open-collector / open-drain driver.

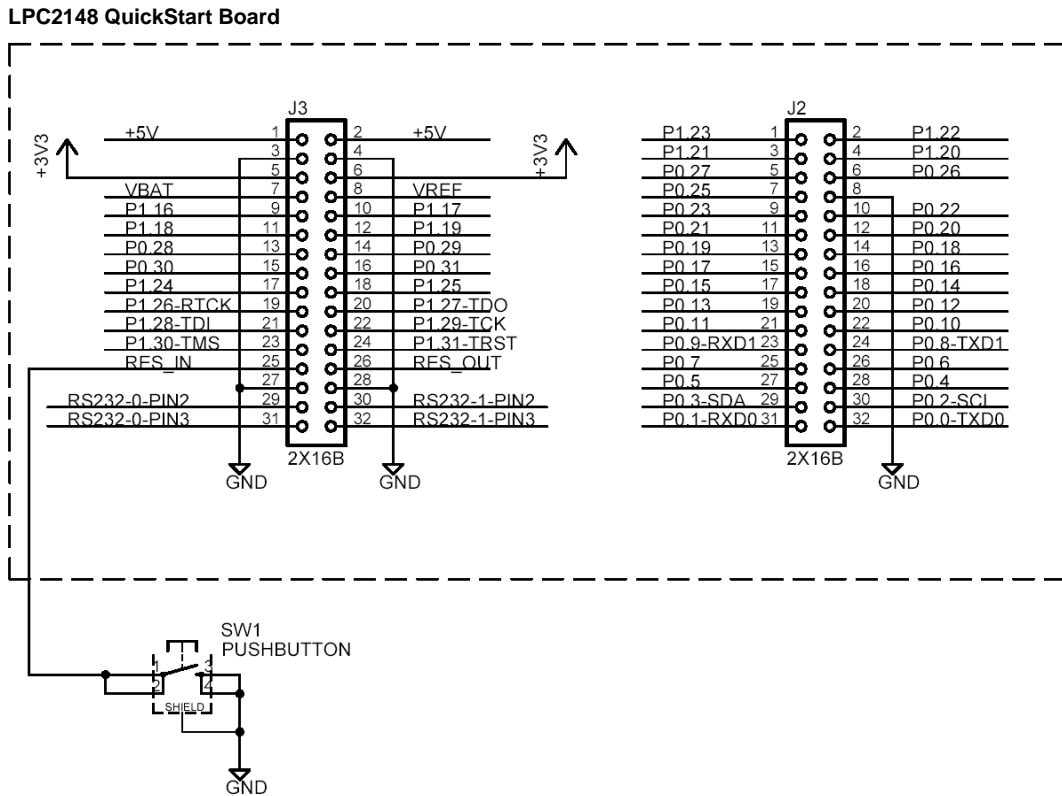

Figure 5 – Example External Reset Push-button

3.2.3 I²C

The LPC2148 microcontroller has an on-chip I²C communication channel (actually two, but one is used and the other is optional). The *LPC2148 USB QuickStart Board* has connected a 2 Kbit E²PROM to this bus. More peripheral units are easily connected to the two-wire I²C bus. *Figure 6* below illustrates how a pin expander circuit (PCF8574) can be connected to the I²C bus.

LPC2148 QuickStart Board

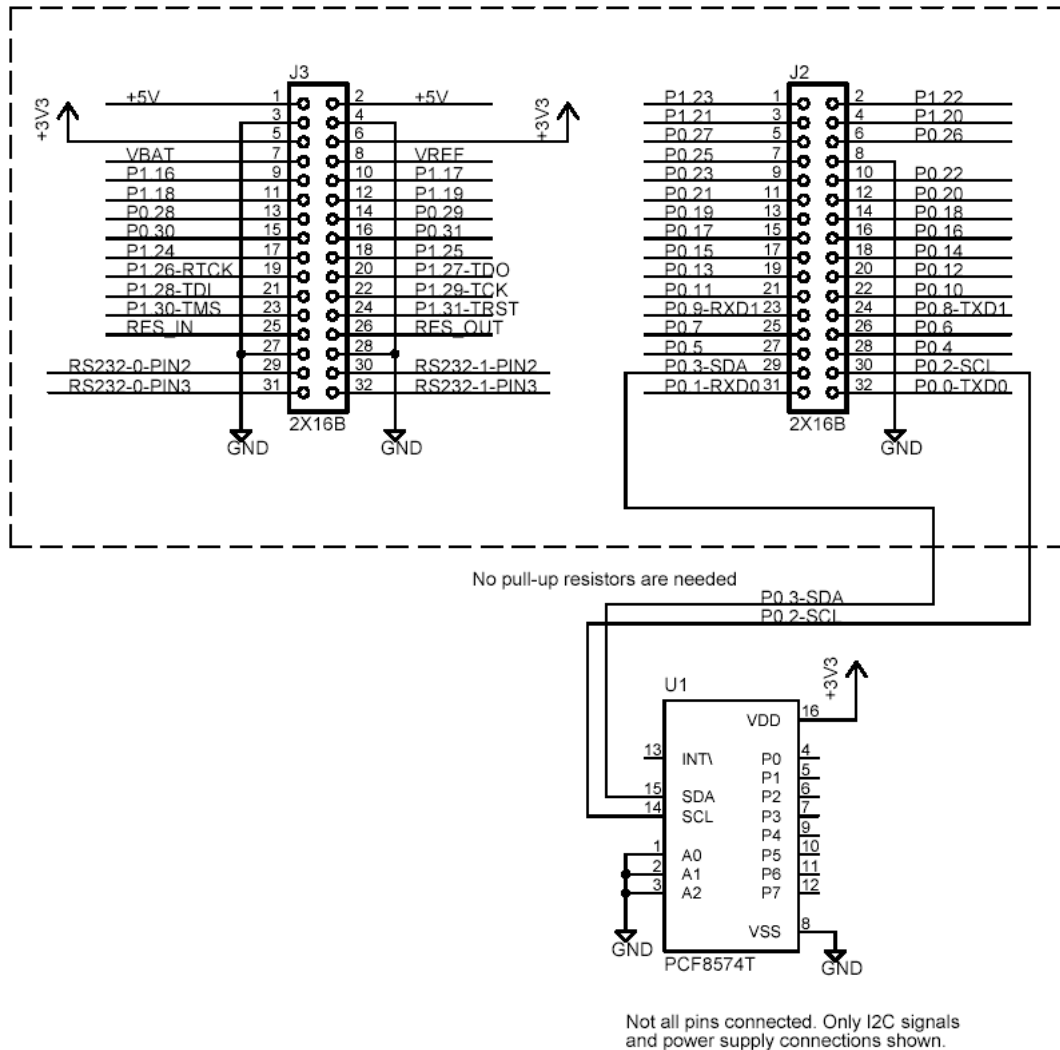

Figure 6 – Example I²C Interface

Note that the pull-up resistors (which are always needed on I²C busses) are included on the *LPC2148 USB QuickStart Board*, and are hence not needed on the external circuit. The pull-up resistors are 3000 ohm each (see *Fel! Hittar inte referenskälla.* for complete board schematics).

If using the second I²C channel do not forget to connect pull-up resistors to these signals also. Note that this must be done even if the I²C functionality is not used/enabled. Pins P0.11 and P0.14 are open-drain I/Os and must have pull-up resistors when configured as outputs. This is unfortunately easy to forget.

3.2.4 SPI

The LPC2148 microcontroller also has two on-chip SPI serial communication channels. *Figure 7* below illustrates how serial E²PROM chip, a shift register and a SD/MMC memory card are connected to the *LPC2148 USB QuickStart Board*. In the schematic below, signal SSEL (i.e. P0.7) has been pulled high. This is normally required when the SPI controller operates as a 'master', and 'master' operation is typically the normal operating mode. Note however that for the LPC214x series, SSEL is no longer required to be pulled high when operating as a SPI master. It can be used as a general purpose I/O. A good use for this pin is to use it as chip select for (one of) the SPI slave(s) to communicate with.

In *Figure 7* below, signal P0.30 is used as an example to control the chip select to the serial E²PROM chip, but for the LPC214x series, it could just as well have been the P0.7 (SSEL) pin (or any other pin). Note that one chip select signal is required for each external chip that is connected to the SPI bus.

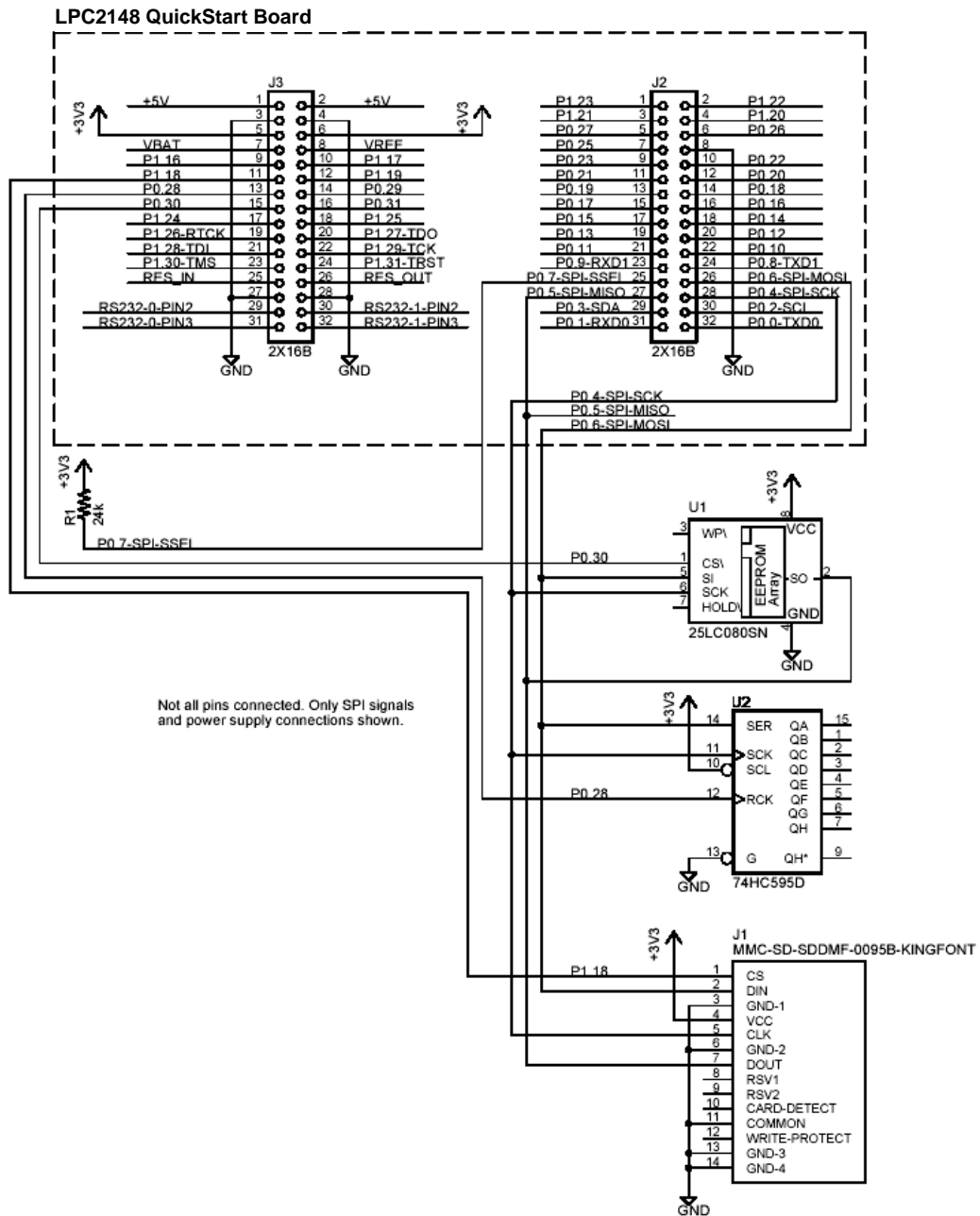

Figure 7 – Example SPI Interface

3.2.5 LEDs

The port pins of the LPC2148 microcontrollers have a 4 mA driving capacity, just enough to directly drive LEDs. *Figure 8* below illustrates how current is sourced from / sink to the microcontroller to drive the LEDs. The resistors limit the current to about 4 mA. The preloaded test program (described in *Section 4.1*) outputs a running-zero on all the port pins (P0.4 – P0.31, P1.16 – P1.31, except the USB pins). A circuit like the one in *Figure 8* below can be used to verify correct operation (use “active low” circuit).

LPC2148 QuickStart Board

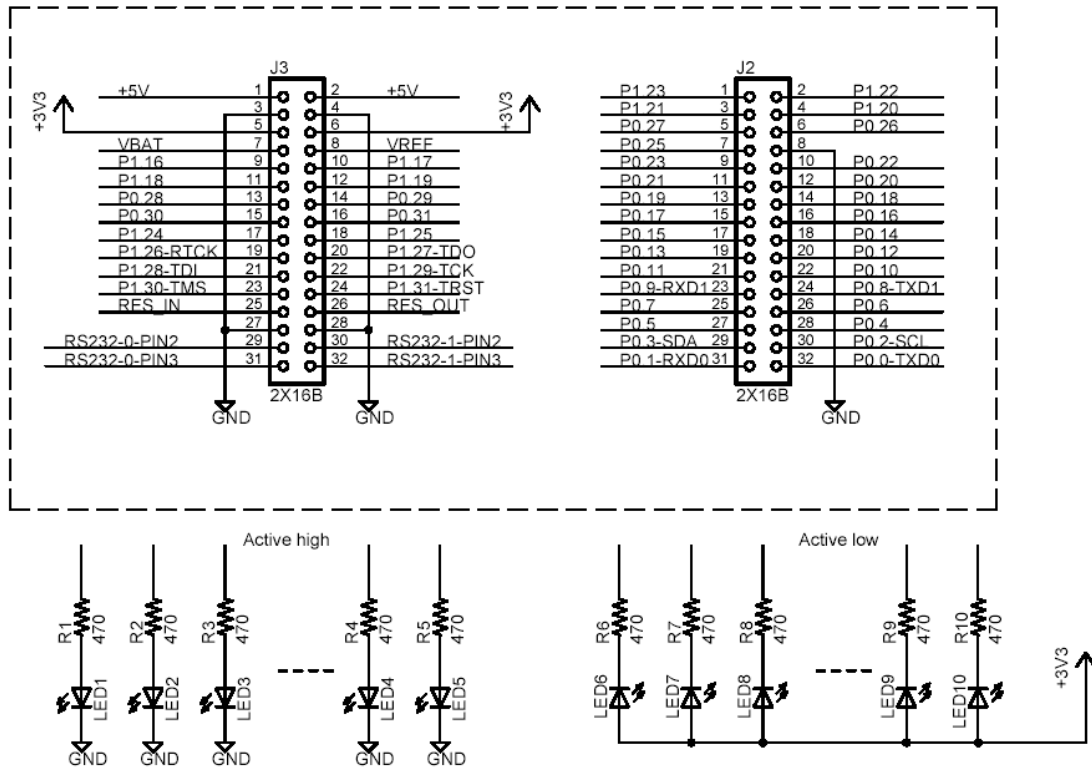

Figure 8 – Example LED Driving

4 Getting Started

4.1 Test program

The *LPC2148 USB QuickStart Board* comes preloaded with a test program. This program can be used to verify that the board operates correctly. A circuit, like the one found in *Figure 8* above, can be used to attach LEDs to port pins P0.4 – P0.31, P1.16 – P1.31 (except the USB pins). Pins P0.0 – P0.1 are tested via the serial channel and pins P0.2 – P0.3 are tested via the I²C bus. Connect also a USB cable between the *LPC2148 USB QuickStart Board* and a PC. The PC will react to the connection and signal that it has found new hardware.

The test program outputs a running-zero to the port pins, meaning that one LED at a time will light (in a running-one pattern). Also, a terminal program should be attached to the RS232 DSUB-9 connector. The test program will output test information regarding the I²C and EEPROM test. Also, the UART/RS232 channel can be tested by typing characters in the terminal program.

The settings for the terminal program are: 38.4 kbps, 8 data bits, no parity bits, and one stop bit (i.e., 8N1).

The output from the test program will look something like in *Figure 9* below. Note that the picture below is just an example and not the actual output text.

```

LPC2106-gcc-newlib v1.0.0.0 - deploy
*****
* Test program for LPC213x QuickStart Board *
* Version: 1.0 *
* Date: 2005-07-12 *
* (C) Embedded Artists 2005 *
*****
* EEPROM and I2C test *
*****
Test #1 - write string 'String #1' to address 0x0000
         - done (status code OK)
         - program cycle completed
Test #2 - write string 'sTrInG #2' to address 0x00a0
         - done (status code OK)
         - program cycle completed
Test #3 - read string from address 0x0000
         - string is 'String #1'
Test #4 - read string from address 0x00a0
         - string is 'sTrInG #2'
Test #5 - write string 'sTrInG #2' to address 0x0004
         - done (status code OK)
         - program cycle completed
Test #6 - read string from address 0x0000
         - string is 'StrisTrInG #2'

Summary of tests: Passed all tests!
*****
* RTC test *
*****
..... test OK!

*****
* I/O and UART test *
* Loop through all I/O pins (running '0') *
* - P0.4 to P0.31, P1.16 to P1.31 *
* (not in above order) *
* - P0.2 to P0.3 tested via EEPROM and I2C test *
* - P0.0 to P0.1 tested via UART test *
* *
* Press any key on terminal and verify echo back *
*****
Received char: t (116 decimal)
Received char: e (101 decimal)
Received char: s (115 decimal)
Received char: t (116 decimal)
Received char: i (105 decimal)
Received char: n (110 decimal)
Received char: g (103 decimal)
...

```

Figure 9 – Example Test Program Output

4.2 Program Development

Consult the *QuickStart Program Development User's Manual* for more information about the *QuickStart Build Environment* from Embedded Artists, and program development for the ARM7 in general.

5 Further Information

The LPC2148 microcontroller is a complex circuit and there exist a number of other documents with a lot more information. The following documents are recommended as a complement to this document.

- [1] NXP LPC2148 Datasheet
<http://ics.nxp.com/products/lpc2000/datasheet/lpc2141.lpc2142.lpc2144.lpc2146.lpc2148.pdf>
- [2] NXP LPC2148 User's Manual
<http://ics.nxp.com/support/documents/microcontrollers/pdf/user.manual.lpc2141.lpc2142.lpc2144.lpc2146.lpc2148.pdf>
- [3] NXP LPC2148 Errata Sheet
<http://ics.nxp.com/support/documents/microcontrollers/pdf/errata.lpc2148.pdf>
- [4] ARM7TDMI Technical Reference Manual. Document identity: DDI0029G
http://www.arm.com/pdfs/DDI0029G_7TDMI_R3_trm.pdf
- [5] ARM Architecture Reference Manual. Document identity: DDI0100E
Book, Second Edition, edited by David Seal, Addison-Wesley: ISBN 0-201-73719-1
Also available in PDF form on the ARM Technical Publications CD
- [6] ARM System Developer's Guide – Designing and Optimizing System Software, by A.N. Sloss, D Symes, C. Wright. Elsevier: ISBN 1-55860-874-5
- [7] Embedded System Design on a Shoestring, by Lewin Edwards.
Newnes: ISBN 0750676094.
- [8] GNU Manuals
<http://www.gnu.org/manual/>
- [9] GNU ARM tool chain for Cygwin
<http://www.gnuarm.com>
- [10] An Introduction to the GNU Compiler and Linker, by Bill Gatliff
<http://www.billgatliff.com>
- [11] LPC2000 Yahoo Group. A discussion forum dedicated entirely to the NXP's LPC2xxx series of microcontrollers.
<http://groups.yahoo.com/group/lpc2000/>
- [12] The Insider's Guide to the NXP's ARM7-Based Microcontrollers, by Trevor Martin.
<http://www.hitex.co.uk/arm/lpc2000book/index.html>

Also note that there can be newer versions of the documents than the ones linked to here. Always check for the latest information / version.

X-ON Electronics

Largest Supplier of Electrical and Electronic Components

Click to view similar products for [Development Boards & Kits - ARM category](#):

Click to view products by [Embedded Artists manufacturer](#):

Other Similar products are found below :

[CWH-CTP-VSPA-YE_CY4541](#) [EVAL-ADUCM320IQSPZ_FRDM-KV31F](#) [POLYPOD-BGA324](#) [POLYPOD-TQ144](#) [POLYPOD-TQ176](#)
[KEA128LEDLIGHTRD_KIT_XMC42_EE1_001](#) [SAFETI-HSK-RM48](#) [LS1024A-RDB](#) [ADM00573](#) [FRDM-KL28Z](#) [PICOHOBBITFL](#)
[MCIMX53-START-R](#) [TWR-K65F180M](#) [KEA128BLDCRD](#) [CC-ACC-MMK-2443](#) [STM8L1528-EVAL](#) [YSPKS5D9E10](#) [YGRPEACHFULL](#)
[TWR-MC-FRDMKE02Z](#) [TWR-K80F150M](#) [CY14NVSRAMKIT-001](#) [EVALSPEAR320CPU](#) [EVB-SCMIMX6SX](#) [MAXWSNENV#](#) [FM0-64L-S6E1C3](#) [MAX32600-KIT#](#) [TMDX570LS04HDK](#) [Z32F3840100KITG](#) [LS1021A-IOT-B](#) [SK-FM3-100PMC-MB9BF516N](#) [TXSD-SV70](#)
[YSTBS3A3E10](#) [YR8A77430HA02BG](#) [STM3240G-USB/NMF](#) [OM13080UL](#) [EVAL-ADUC7120QSPZ](#) [CYDP-KIT-13638](#) [OM13063UL](#)
[ATAVRPARROT](#) [OM13090UL](#) [YSPEHMI1S20](#) [TXSD-SV71](#) [YGRPEACHNORMAL](#) [SK-FM3-176PMC-ETHERNET](#) [HVP-KV11Z75M](#)
[OM13076UL](#) [LX2RDBKIT2-25G](#)