



ELECTRONICS, INC.  
44 FARRAND STREET  
BLOOMFIELD, NJ 07003  
(973) 748-5089

## **NTE1901 Integrated Circuit Negative Adjustable Voltage Regulator, -1.2V to -37V, 100mA**

### **Description:**

The NTE1901 is an adjustable 3-terminal negative voltage regulator in a TO92 type package capable of supplying 100mA over a -12,V to -37V output range. It is exceptionally easy to use and both line and load regulation are better than standard fixed regulators.

In addition to higher performance than fixed regulators, the NTE1901 offers full overload protection. Included on the chip are current limit, thermal overload protection and safe area protection. All overload protection circuitry remains fully functional even if the adjustment terminal is disconnected.

Normally, no capacitors are needed unless the device is situated more than 6 inches from the input filter capacitor in which case an input bypass is needed. An optional output capacitor can be added to improve transient response. The adjustment terminal can be bypassed to achieve very high ripple rejection ratios which are difficult to achieve with standard 3-terminal regulators.

Besides replacing fixed regulators, the NTE1901 is useful in a wide variety of other applications. Since the regulator is "floating" and sees only the input-to-output differential voltage, supplies of several hundred volts can be regulated as long as the maximum input-to-output differential is not exceeded.

Also, it makes an especially simple adjustable switching regulator, a programmable output regulator, or by connecting a fixed resistor between the adjustment and output, the NTE1901 can be used as a precision current regulator. Supplies with electronic shutdown can be achieved by clamping the adjustment terminal to ground which programs the output to 1.2V where most loads draw little current.

### **Features:**

- Adjustable Output Down to 1.2V
- Guaranteed 100mA Output Current
- Line Regulation Typically 0.01%/V
- Load Regulation Typically 0.1%
- Current Limit Constant with Temperature
- Eliminates the Need to Stock Many Voltages
- Standard 3-Lead Transistor Package
- 80db Ripple Rejection
- Output is Short Circuit Protected

**Absolute Maximum Ratings:** ( $T_A = +25^\circ\text{C}$  unless otherwise specified)

Power Dissipation, $P_D$ .....	Internally Limited
Input–Output Voltage Differential, $V_I - V_O$ .....	40V
Operating Junction Temperature Range, $T_J$ .....	$-40^\circ$ to $+125^\circ\text{C}$
Storage Temperature Range, $T_{stg}$ .....	$-55^\circ$ to $+150^\circ\text{C}$
Lead Temperature (During Soldering, 10sec), $T_L$ .....	$+300^\circ\text{C}$

**Electrical Characteristics:** (Note 1 unless otherwise specified)

Parameter	Symbol	Test Conditions	Min	Typ	Max	Unit
Line Regulation	$Reg_{Line}$	$T_A = +25^\circ\text{C}$ , $3V \leq (V_{IN} - V_O) \leq 40V$ , Note 2	–	0.01	0.04	%/V
		$3V \leq (V_{IN} - V_O) \leq 40V$ , Note 2	–	0.02	0.07	%/V
Load Regulation	$Reg_{Load}$	$T_A = +25^\circ\text{C}$ , $5mA \leq I_O \leq 100mA$ , Note 2	–	0.1	0.5	%
		$5mA \leq I_O \leq 100mA$ , Note 2	–	0.1	0.5	%
Thermal Regulation		$T_A = +25^\circ\text{C}$ , 10ms Pulse	–	0.04	0.2	%/W
Adjustment Pin Current	$I_{Adj}$		–	50	100	$\mu\text{A}$
Adjustment Pin Current Change	$I_{Adj}$	$5mA \leq I_L \leq 100mA$ , $3V \leq (V_{IN} - V_O) \leq 40V$	–	0.2	5.0	$\mu\text{A}$
Reference Voltage	$V_{ref}$	$5mA \leq I_L \leq 100mA$ , $3V \leq (V_{IN} - V_O) \leq 40V$ , $P \leq 625mW$ , Note 3	1.20	1.25	1.30	V
Temperature Stability	$T_S$	$-25^\circ\text{C} \leq T_J \leq +125^\circ\text{C}$	–	0.65	–	%
Minimum Load Currnt	$I_{L(min)}$	$(V_{IN} - V_O) \leq 40V$	–	3.5	5.0	mA
		$3V \leq (V_{IN} - V_O) \leq 15V$	–	2.2	3.5	mA
MaximumOutput Current Limit	$I_{max}$	$3V \leq (V_{IN} - V_O) \leq 13V$	100	200	300	mA
		$(V_{IN} - V_O) \leq 40V$	25	50	150	mA
RMS Output Noise, % of $V_{OUT}$	N	$T_A = +25^\circ\text{C}$ , $10\text{Hz} \leq f \leq +10\text{kHz}$	–	0.003	–	%
Ripple Rejection Ratio	RR	$V_{OUT} = -10V$ , $f = 120\text{Hz}$ , $C_{ADJ} = 0$	–	65	–	dB
		$C_{ADJ} = 10\mu\text{F}$	66	80	–	dB
Long Term Stability	S	$T_J = +125^\circ\text{C}$ , 100 Hours	–	0.3	1.0	%

Note 1. Unless otherwise noted, these specifications apply:  $-25^\circ \leq T_J \leq +125^\circ\text{C}$ ,  $V_{IN} - V_{OUT} = 5V$ ,  $I_{OUT} = 40mA$ , and  $I_{MAX} = 100mA$ . Although power dissipation is internally limited, these specifications are applicable for power dissipations up to 625mW.

Note 2. Regulation is measured at constant junction temperature, using pulse testing with low duty cycle. Changes in output voltage due to heating effects are covered under the specifications for thermal regulation.

Note 3. Thermal resistance o the TO92 package is  $180^\circ\text{C/W}$  junction to ambient with 0.4” leads from a PC board and  $160^\circ\text{C/W}$  junction to ambient with 0.125” lead length to PC board.

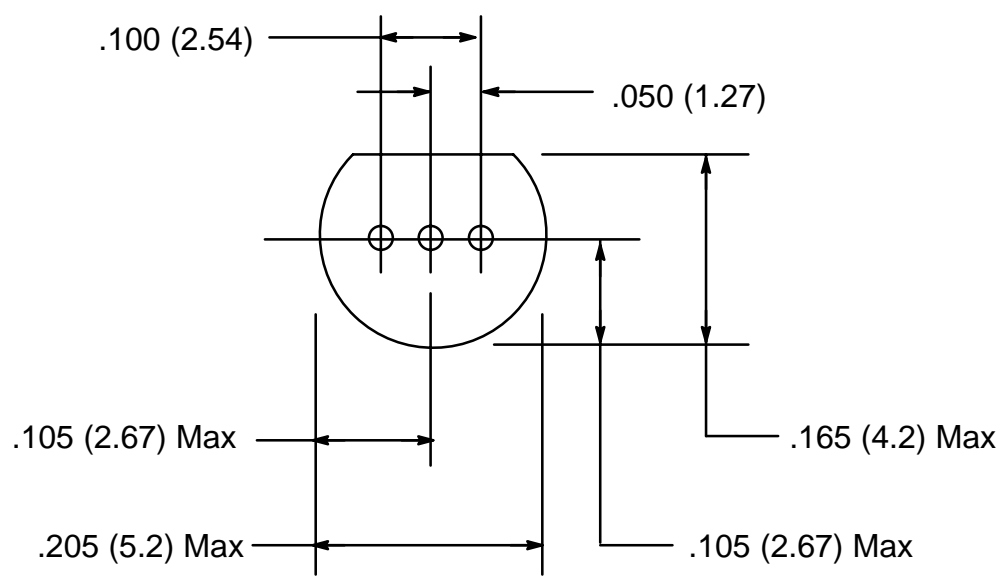
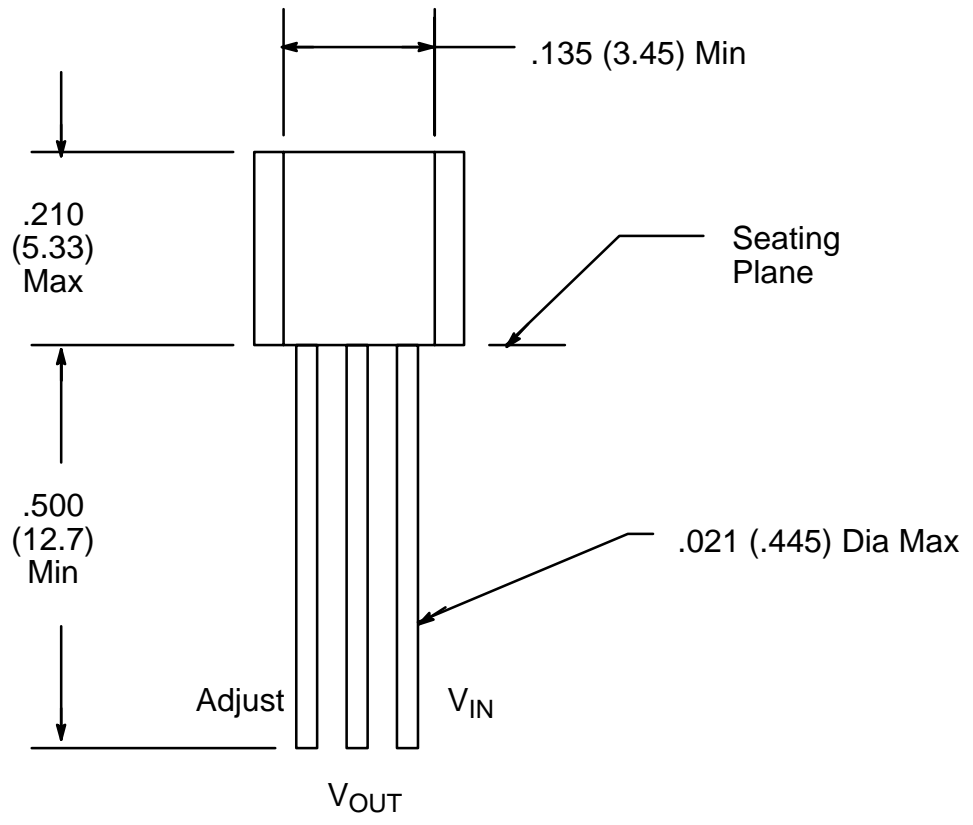

## X-ON Electronics

Largest Supplier of Electrical and Electronic Components

*Click to view similar products for [Linear Voltage Regulators](#) category:*

*Click to view products by [NTE manufacturer](#):*

Other Similar products are found below :

[LV56831P-E](#) [LV5684PVD-XH](#) [MAX202ECWE-LF](#) [MCDTSA6-2R](#) [L4953G](#) [L7815ACV-DG](#) [PQ3DZ53U](#) [LV56801P-E](#)  
[TCR3DF13,LM\(CT](#) [TCR3DF39,LM\(CT](#) [TLE42794G](#) [L78L05CZ/1SX](#) [L78LR05DL-MA-E](#) [L78MR05-E](#) [033150D](#) [033151B](#) [090756R](#)  
[636416C](#) [NCV78M15BDTG](#) [702482B](#) [714954EB](#) [TLE42794GM](#) [TLE42994GM](#) [ZMR500QFTA](#) [BA033LBSG2-TR](#)  
[NCV78M05ABDTRKG](#) [NCV78M08BDTRKG](#) [NCP7808TG](#) [NCV571SN12T1G](#) [LV5680P-E](#) [CAJ24C256YI-GT3](#) [L78M15CV-DG](#) [L9474N](#)  
[TLS202B1MBV33HTSA1](#) [L79M05T-E](#) [NCP571SN09T1G](#) [MAX15006AASA/V+](#) [MIC5283-5.0YML-T5](#) [L4969URTR-E](#) [L78LR05D-MA-E](#)  
[NCV7808BDTRKG](#) [L9466N](#) [NCP7805ETG](#) [SC7812CTG](#) [NCV7809BTG](#) [NCV571SN09T1G](#) [NCV317MBTG](#) [MC78M15CDTT5G](#)  
[MC78M12CDTT5G](#) [L9468N](#)