



**ELECTRONICS, INC.**  
 44 FARRAND STREET  
 BLOOMFIELD, NJ 07003  
 (973) 748-5089

## NTE1942 Integrated Circuit Positive Adjustable Voltage Regulator, 2.85V to 36V, 2A

**Description:**

The NTE1942 is an integrated circuit for voltage and current programmable regulation. Current limiting, power limiting, thermal shutdown, and input overvoltage protection (up to 60V) make the NTE1942 virtually blowout proof. The NTE1942 can be used to replace fixed voltage regulators when high output voltage precision is required.

**Features:**

- Adjustable Output Current Up to 2A (Guaranteed Up to  $T_J = +150^{\circ}\text{C}$ )
- Adjustable Output Voltage Down to 2.85V
- Input Overvoltage Protection (Up to 60V, 10ms)
- Short Circuit Protection
- Output Transistor S.O.A. Protection
- Thermal Overload Protection
- Low Bias Current On Regulation Terminal
- Low Standby Current Drain

**Absolute Maximum Ratings:**

DC Input Voltage, $V_i$ .....	40V
Peak Input Voltage (10ms), $V_i$ .....	60V
In-Out Operating Differential Voltage, $\Delta V_{i-o}$ .....	32V
Output Current, $I_o$ .....	internally limited
Power Dissipation, $P_{tot}$ .....	internally limited
Storage Temperature Range, $T_{stg}$ .....	$-55^{\circ}$ to $+150^{\circ}\text{C}$
Operating Junction Temperature Range, $T_J$ .....	$-25^{\circ}$ to $+150^{\circ}\text{C}$
Maximum Thermal Resistance, Junction-to-Case, $R_{thJC}$ .....	$+3^{\circ}\text{C/W}$
Maximum Thermal Resistance, Junction-to-Ambient, $R_{thJA}$ .....	$+50^{\circ}\text{C/W}$

**Electrical Characteristics:** ( $T_J = -25^\circ$  to  $+150^\circ\text{C}$  unless otherwise specified)

Parameter	Symbol	Test Conditions	Min	Typ	Max	Unit	
<b>GENERAL</b>							
Quiescent Drain Current (Pin3)	$I_d$	$V_i = 20\text{V}, T_J = +25^\circ\text{C}$	–	4.2	9.2	mA	
Output Noise Voltage	$e_N$	$V_o = V_{\text{ref}}, I_o = 10\text{mA}, B = 1\text{MHz}$	–	80	–	$\mu\text{V}$	
<b>VOLTAGE REGULATION LOOP</b>							
Reference Voltage (Pin4)	$V_{\text{ref}}$	$V_i = 20\text{V}, I_o = 10\text{mA}, T_J = +25^\circ\text{C}$	2.65	2.77	2.85	V	
Average Temperature Coefficient of Reference Voltage	$\frac{\Delta V_{\text{ref}}}{\Delta T}$	$V_i = 20\text{V}, I_o = 10\text{mA}$	–	–0.25	–	$\text{mV}/^\circ\text{C}$	
			–	–1.5	–	$\text{mV}/^\circ\text{C}$	
Output Voltage Range	$V_o$	$I_o = 10\text{mA}, T_J = +25^\circ\text{C}$	2.85	–	36	V	
Voltage Load Regulation	$\frac{\Delta V_o}{V_o}$	$\Delta I_o = 2.0\text{A}, \text{Note 1}$	–	0.15	1.0	%	
		$\Delta I_o = 1.5\text{A}, \text{Note 1}$	–	1.0	0.5	%	
Supply Voltage Rejection Ratio	SVR	$V_o = 5\text{V}, I_o = 500\text{mA}, \Delta V_i = 100\text{V}_{\text{pp}}, f = 100\text{Hz}, \text{Note 2}$	60	70	–	dB	
Line Regulation	$\frac{\Delta V_i}{\Delta V_o}$	$V_o = 5\text{V}, I_o = 500\text{mA}, V_i = 8\text{V to } 18\text{V}, T_J = +25^\circ\text{C}$	54	70	–	dB	
Output Impedance	$Z_o$	$V_i = 10\text{V}, V_o = V_{\text{ref}}, I_o = 0.5\text{A}, f = 100\text{Hz}$	$1.5 \times 10^{-3}$			$\Omega$	
Drop-out Voltage between Pin1 and Pin5		$I_o = 1.5\text{A}, \frac{\Delta V_o}{V_o} \leq 2\%$	–	2.0	2.5	V	
Bias Current at Pin4	$I_4$	$T_J = +25^\circ\text{C}$	–	3	10	$\mu\text{A}$	
Average Temperature Coefficient (Pin4)	$\frac{\Delta I_4}{\Delta T \cdot I_4}$		–	–0.5	–	$\%/^\circ\text{C}$	
<b>CURRENT REGULATION LOOP</b>							
Current Limit Sense Voltage between Pin5 and Pin2	$V_{\text{SC}}$	$V_i = 10\text{V}, V_o = V_{\text{ref}}, T_J = +25^\circ\text{C}$	–	0.45	–	V	
Average Temperature Coefficient of $V_{\text{SC}}$			–	0.03	–	$\%/^\circ\text{C}$	
Current Load Regulation	$\frac{\Delta I_o}{I_o}$	$V_i = 10\text{V}, \Delta V_o = 3\text{V}$	$I_o = 0.5\text{A}$	–	1.4	–	%
			$I_o = 1.0\text{A}$	–	1.0	–	%
			$I_o = 1.5\text{A}$	–	0.9	–	%
Short Circuit Current	$I_{\text{SC}}$	$V_i - V_o = 14\text{V}, \text{Pin2 and Pin5 short circuited}$	2.0	2.5	3.6	A	

Note 1. A load step of 2A can be applied provided that the input–output differential voltage is lower than 20V.

Note 2. The same performance can be maintained at higher output levels if a bypassing capacitor is provided between Pin2 and Pin4.

### Pin Connection Diagram

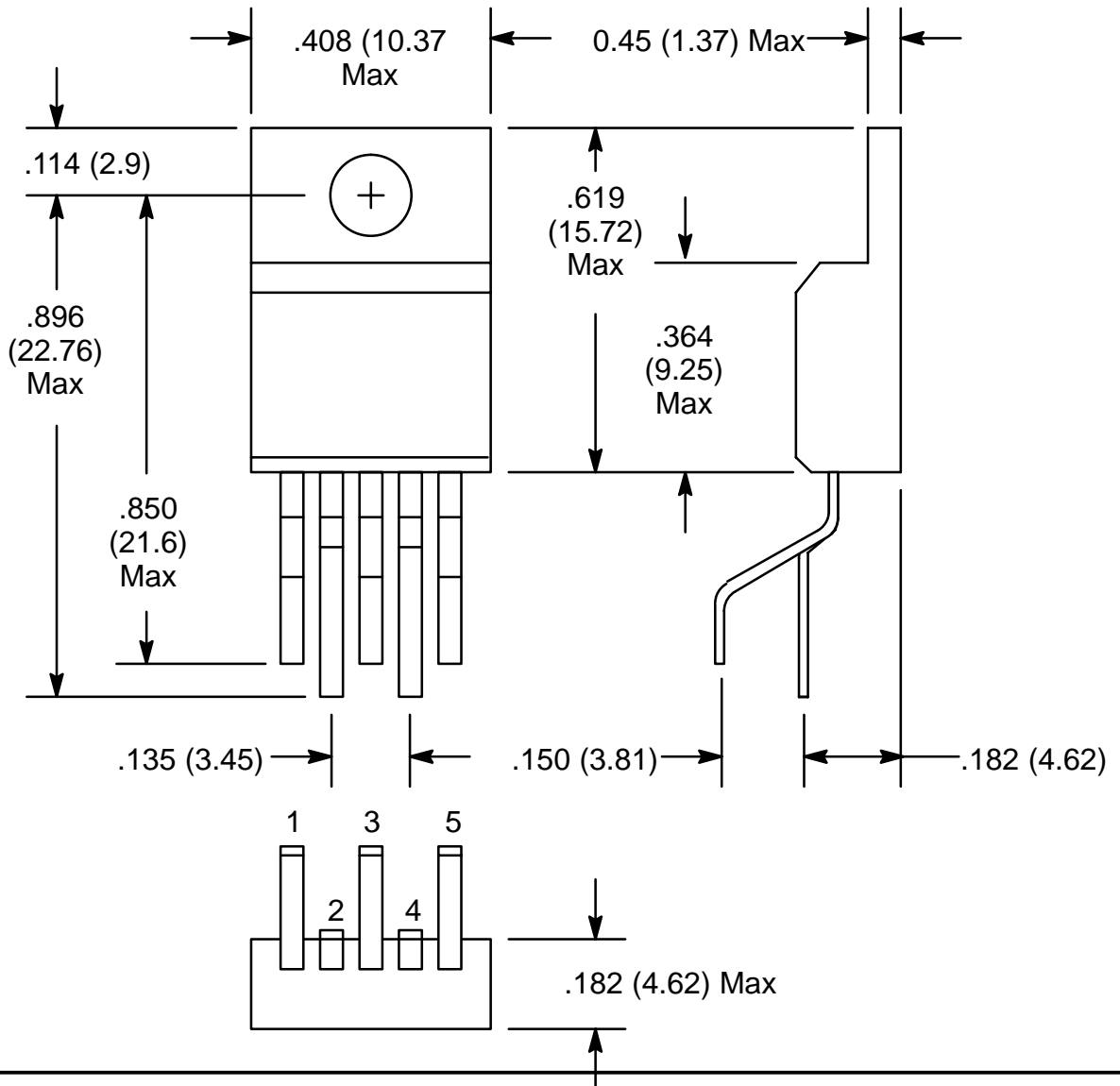
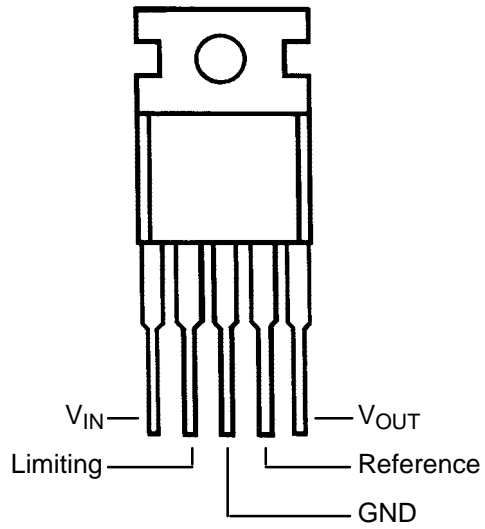

## X-ON Electronics

Largest Supplier of Electrical and Electronic Components

*Click to view similar products for [Linear Voltage Regulators](#) category:*

*Click to view products by [NTE manufacturer](#):*

Other Similar products are found below :

[LV56831P-E](#) [LV5684PVD-XH](#) [MAX202ECWE-LF](#) [MCDTSA6-2R](#) [L4953G](#) [L7815ACV-DG](#) [PQ3DZ53U](#) [LV56801P-E](#)  
[TCR3DF13,LM\(CT](#) [TCR3DF39,LM\(CT](#) [TLE42794G](#) [L78L05CZ/1SX](#) [L78LR05DL-MA-E](#) [L78MR05-E](#) [033150D](#) [033151B](#) [090756R](#)  
[636416C](#) [NCV78M15BDTG](#) [702482B](#) [714954EB](#) [TLE42794GM](#) [TLE42994GM](#) [ZMR500QFTA](#) [BA033LBSG2-TR](#)  
[NCV78M05ABDTRKG](#) [NCV78M08BDTRKG](#) [NCP7808TG](#) [NCV571SN12T1G](#) [LV5680P-E](#) [CAJ24C256YI-GT3](#) [L78M15CV-DG](#) [L9474N](#)  
[TLS202B1MBV33HTSA1](#) [L79M05T-E](#) [NCP571SN09T1G](#) [MAX15006AASA/V+](#) [MIC5283-5.0YML-T5](#) [L4969URTR-E](#) [L78LR05D-MA-E](#)  
[NCV7808BDTRKG](#) [L9466N](#) [NCP7805ETG](#) [SC7812CTG](#) [NCV7809BTG](#) [NCV571SN09T1G](#) [NCV317MBTG](#) [MC78M15CDTT5G](#)  
[MC78M12CDTT5G](#) [L9468N](#)