



ELECTRONICS, INC.
 44 FARRAND STREET
 BLOOMFIELD, NJ 07003
 (973) 748-5089

NTE97 Silicon NPN Transistor HV Darlington Power Amp, Switch

Description:

The NTE97 is a silicon NPN Darlington transistor in a TO3 type package designed for high voltage, high-speed, power switching in inductive circuits where fall-time is critical. They are particularly suited for line operated switch-mode applications.

Applications:

- Switching Regulators
- Inverters
- Solenoid and Relay Drivers

Absolute Maximum Ratings:

Collector–Emitter Voltage, $V_{CEO(sus)}$	400V
Collector–Emitter Voltage, $V_{CEX(sus)}$	450V
Collector–Emitter Voltage, V_{CEV}	500V
Emitter–Base Voltage, V_{EB}	8V
Collector Current, I_C	
Continuous	10A
Peak (Note 1)	20A
Base Current, I_B	
Continuous	2.5A
Peak (Note 1)	5.0A
Total Power Dissipation ($T_C = +25^\circ C$), P_D	150W
Derate Above $+25^\circ C$	0.86W/ $^\circ C$
Total Power Dissipation ($T_C = +100^\circ C$), P_D	100W
Operating Junction Temperature Range, T_J	-65° to $+200^\circ C$
Storage Temperature Range, T_{stg}	-65° to $+200^\circ C$
Thermal Resistance, Junction–to–Case, R_{thJC}	1.17 $^\circ C/W$
Lead Temperature (During Soldering, 1/8" from case, 5sec), T_L	$+275^\circ C$

Note 1. Pulse test: Pulse Width = 5ms, Duty Cycle \leq 10%.

Electrical Characteristics: ($T_C = +25^\circ\text{C}$ unless otherwise specified)

Parameter	Symbol	Test Conditions	Min	Typ	Max	Unit
OFF Characteristics (Note 2)						
Collector–Emitter Sustaining Voltage	$V_{\text{CEO(sus)}}$	$I_C = 250\text{mA}, I_B = 0, V_{\text{clamp}} = 400\text{V}$	400	–	–	V
	$V_{\text{CEX(sus)}}$	$I_C = 1\text{A}, V_{\text{clamp}} = 450\text{V}, T_C = +100^\circ\text{C}$	450	–	–	V
		$I_C = 5\text{A}, V_{\text{clamp}} = 450\text{V}, T_C = +100^\circ\text{C}$	325	–	–	V
Collector Cutoff Current	I_{CEV}	$V_{\text{CEV}} = 500\text{V}, V_{\text{BE(off)}} = 1.5\text{V}$	–	–	0.25	mA
		$V_{\text{CEV}} = 500\text{V}, V_{\text{BE(off)}} = 1.5\text{V}, T_C = +100^\circ\text{C}$	–	–	5.0	mA
	I_{CER}	$V_{\text{CEV}} = 500\text{V}, R_{\text{BE}} = 50\Omega, T_C = +100^\circ\text{C}$	–	–	5.0	mA
Emitter Cutoff Current	I_{EBO}	$V_{\text{EB}} = 8\text{V}, I_C = 0$	–	–	175	mA
ON Characteristics (Note 3)						
DC Current Gain	h_{FE}	$V_{\text{CE}} = 5\text{V}, I_C = 2.5\text{A}$	40	–	500	
		$V_{\text{CE}} = 5\text{V}, I_C = 5\text{A}$	30	–	300	
Collector–Emitter Saturation Voltage	$V_{\text{CE(sat)}}$	$I_C = 5\text{A}, I_B = 250\text{mA}$	–	–	1.9	V
		$I_C = 5\text{A}, I_B = 250\text{mA}, T_C = +100^\circ\text{C}$	–	–	2.0	V
		$I_C = 10\text{A}, I_B = 1\text{A}$	–	–	2.9	V
Base–Emitter Saturation Voltage	$V_{\text{BE(sat)}}$	$I_C = 5.2\text{A}, I_B = 250\text{mA}$	–	–	2.5	V
		$I_C = 5\text{A}, I_B = 250\text{mA}, T_C = +100^\circ\text{C}$	–	–	2.5	V
Diode Forward Voltage	V_{F}	$I_{\text{F}} = 5\text{A}, \text{Note 3}$	–	3	5	V
Dynamic Characteristics						
Small–Signal Current Gain	h_{fe}	$V_{\text{CE}} = 10\text{V}, I_C = 1\text{A}, f_{\text{test}} = 1\text{MHz}$	10	–	–	
Output Capacitance	C_{ob}	$V_{\text{CB}} = 50\text{V}, I_{\text{E}} = 0, f_{\text{test}} = 100\text{kHz}$	60	–	275	pF
Switching Characteristics (Resistive Load)						
Delay Time	t_{d}	$V_{\text{CC}} = 250\text{V}, I_C = 5\text{A}, I_{\text{B1}} = 250\text{mA}, V_{\text{BE(off)}} = 5\text{V}, t_{\text{p}} = 50\mu\text{s}, \text{Duty Cycle} \leq 2\%$	–	0.05	0.2	μs
Rise Time	t_{r}		–	0.25	0.6	μs
Storage Time	t_{s}		–	1.2	3.0	μs
Fall Time	t_{f}		–	0.6	1.5	μs
Switching Characteristics (Inductive Load, Clamped)						
Storage Time	t_{sv}	$I_C = 5\text{A Peak}, V_{\text{clamp}} = 450\text{V}, I_{\text{B1}} = 250\text{mA}, V_{\text{BE(off)}} = 5\text{V}, T_C = +100^\circ\text{C}$	–	2.1	5.0	μs
Crossover Time	t_{c}		–	1.3	3.3	μs
Storage Time	t_{sv}	$I_C = 5\text{A Peak}, V_{\text{clamp}} = 450\text{V}, I_{\text{B1}} = 250\text{mA}, V_{\text{BE(off)}} = 5\text{V}, T_C = +25^\circ\text{C}$	–	0.92	–	μs
Crossover Time	t_{c}		–	0.5	–	μs

Note 2. Pulse test: Pulse Width = $300\mu\text{s}$, Duty Cycle $\leq 2\%$.

Note 3. The internal Collector–Emitter diode can eliminate the need for an external diode to clamp inductive loads. Tests have shown that the Forward Recovery Voltage (V_{F}) of this diode is comparable to that of typical fast recovery rectifiers.

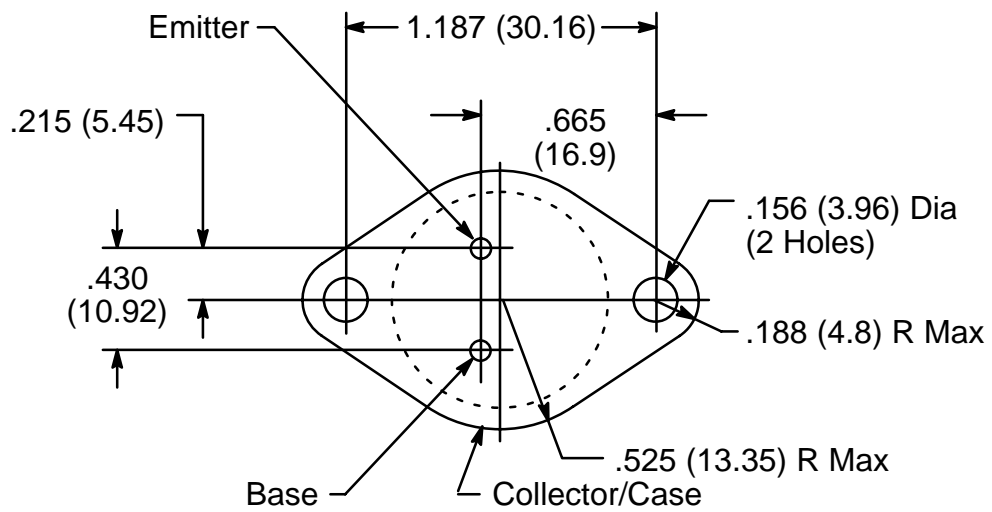
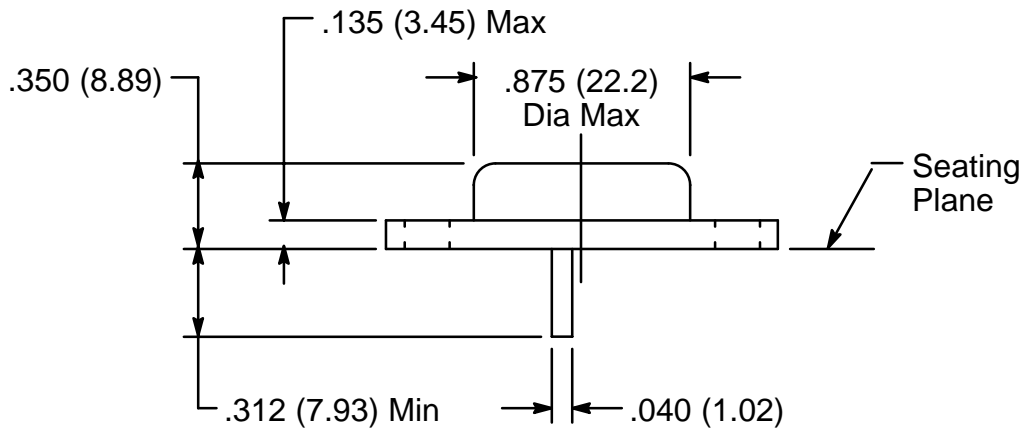
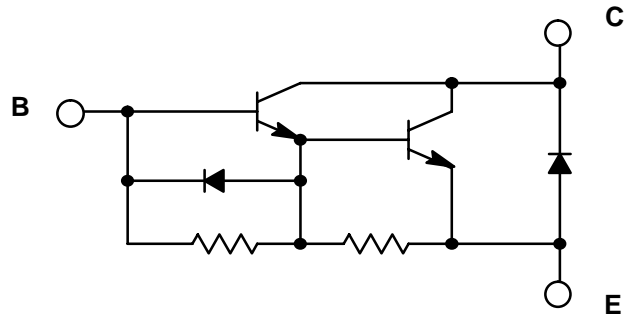

X-ON Electronics

Largest Supplier of Electrical and Electronic Components

Click to view similar products for [Darlington Transistors](#) category:

Click to view products by [NTE manufacturer](#):

Other Similar products are found below :

[281287X](#) [SMMBT6427LT1G](#) [2N7371](#) [BDV64B](#) [JANTXV2N6287](#) [028710A](#) [SMMBTA64LT1G](#) [2N6350](#) [2SB1214-TL-E](#)
[SMMBTA14LT1G](#) [SBSP52T1G](#) [NJVMJD117T4G](#) [Jantx2N6058](#) [2N6353](#) [LB1205-L-E](#) [500-00005](#) [2N6053](#) [NJVMJD112G](#) [Jan2N6350](#)
[Jantx2N6352](#) [Jantx2N6350](#) [BULN2803LVS](#) [ULN2001N](#) [2SB1383](#) [2SB1560](#) [2SB852KT146B](#) [TIP112TU](#) [TIP122TU](#) [BCV27](#) [MMBTA13-](#)
[TP](#) [MMBTA14-TP](#) [MMSTA28T146](#) [BSP50H6327XTSA1](#) [KSH122TF](#) [NTE2557](#) [NJVNJD35N04T4G](#) [TIP115](#) [MPSA29-D26Z](#) [MJD127T4](#)
[FJB102TM](#) [BCV26E6327HTSA1](#) [BCV46E6327HTSA1](#) [BCV47E6327HTSA1](#) [BSP61H6327XTSA1](#) [BU941ZPFI](#) [2SB1316TL](#) [2SD1980TL](#)
[NTE2350](#) [NTE245](#) [NTE246](#)