



RAYSTAR

曜凌光電股份有限公司

住址: 42878 台中市大雅区科雅路 25 號 5F WEB: <http://www.Raystar-Optronics.com>
5F., No.25, Keya Rd., Daya Dist., Taichung E-mail: sales@raystar-optronics.com
City 428, Taiwan Tel:886-4-2565-0761 Fax : 886-4-2565-0760

RFC350P-EIW-DBC

SPECIFICATION

CUSTOMER:

APPROVED BY	
PCB VERSION	
DATE	

FOR CUSTOMER USE ONLY

SALES BY	APPROVED BY	CHECKED BY	PREPARED BY

Release DATE:

Revision History

VERSION	DATE	REVISED PAGE NO.	Note
0	2015/07/29		First issue
A	2016/01/21		Modify Static electricity test
B	2016/08/11		Modify Vibration test
C	2016/10/17		Modify Summary
D	2017/03/31		Add Aspect Ratio

Contents

- 1.Module Classification Information
- 2.Summary
- 3.General Specification
- 4.Interface
- 5.Contour Drawing
- 6.Block Diagram
- 7.Absolute Maximum Ratings
- 8.Electrical Characteristics
- 9.DC Characteristics
- 10.AC Characteristics
- 11.Optical Characteristics
- 12.Reliability
- 13.Touch Panel Information
- 14.Package Specification
- 15.Initial Code For Reference
- 16.Other

1.Module Classification Information

R	F	C	35	0P	-	E	I	W	-	D	B	C
1	2	3	4	5	-	6	7	8	-	9	10	11

Item	Description	
1	R : Raystar Optronics Inc.	
2	Display Type : F→TFT Type, J→ Custom TFT	
3	Solution: A: 128x160 B:320x234 C:320x240 D:480x234 E:480x272 F:800x480 G:640x480 H:1024x600 I:320x480 J:240x320 K:1280x800 L:240x400 M:1024x768 N:128x128 O:480x800 P:640x320 Q:800x600 S:480x128 T:800x320	
4	Display Size : 3.5" TFT	
5	Version Code.	
6	Model Type: A : TFT LCD E : TFT+FR+CONTROL BOARD J : TFT+FR+A/D BOARD N : TFT+FR+A/D BOARD+CONTROL BOARD S : TFT+FR+POWER BOARD (DC TO DC) 1 : TFT+CONTROL BOARD	6 : TFT+FR H : TFT+D/V BOARD I : TFT+FR+D/V BOARD B : TFT+POWER BD
7	Polarizer Type, Temperature range, View direction	I→Transmissive, W. T, 6:00 ; C→Transmissive, N. T, 6:00 L→Transmissive, W.T,12:00 ; F→Transmissive, N.T,12:00 Y→Transmissive,W.T, IPS TFT ; A→Transmissive, N.T, IPS TFT Z→Transmissive, W.T, O-TFT R→Transmissive, Super W.T, O-TFT N→Transmissive, Super W.T, 6:00; Q→Transmissive, Super W.T, 12:00 V→Transmissive, Super W.T, VA TFT
8	Backlight	W : LED, White H : LED, High Light White F : CCFL, White
9	Driver Method	D: Digital A: Analog L : LVDS M:MIPI
10	Interface	N : without control board A : 8Bit B : 16Bit S:SPI Interface R: RS232 U:USB I: I2C
11	TS	N : Without TS S : resistive touch panel C : capacitive touch panel capacitive touch panel (G-F-F) G : capacitive touch panel(G-G)

2.Summary

TFT 3.5" is a TN transmissive type color active matrix TFT liquid crystal display that use amorphous silicon TFT as switching devices. This module is composed of a TFT_LCD module, it is usually designed for industrial application and this module follows RoHs,

3.General Specifications

- Size: 3.5 inch
- Dot Matrix: 320 x RGB x 240 dots
- Module dimension: 93.5 x 66.44 x 9.85 mm
- Active area: 70.08 x 52.56 mm
- Dot pitch: 0.073 x 0.219 mm
- LCD type: TFT, Normally White, Transmissive
- View Direction: 12 o'clock
- Gray Scale Inversion Direction: 6 o'clock
- Aspect Ratio: 4:3
- Backlight Type: LED ,Normally White
- Controller IC: RA8875
- Interface: Digital 8080 family MPU
- With /Without TP: With CTP
- Surface: No Anti-Glare

*Color tone slight changed by temperature and driving voltage.

4.Interface

4.1. LCM PIN Definition (CON2)

Pin	Symbol	Function	Remark
1	GND	System ground	
2	VDD	Power Supply : +3.3V	
3	NC	No connect	
4	RS	Data/Command select	
5	WR	Write strobe signal	
6	RD	Read strobe signal	
7~22	DB0~DB15	Data bus	
23	WAIT	Wait Signal Output(H:active)	
24	CTP_INT	CTP Interrupt Signal From Touch Panel Module To Host	
25	CS	Chip select	
26	RST	Hardware reset	
27	NC	No connect	
28	NC	No connect	
29	CTP_SCL	CTP Serial IIC Clock	
30	CTP_SDA	CTP Serial IIC Data	
31	CTP_RST	CTP Reset Signal	
32	CTP_WAKE	CTP External Interrupt Signal From Host	
33~34	VLED-	Power for LED backlight cathode	
35~36	VLED+	Power for LED backlight anode	

5. Contour Drawing

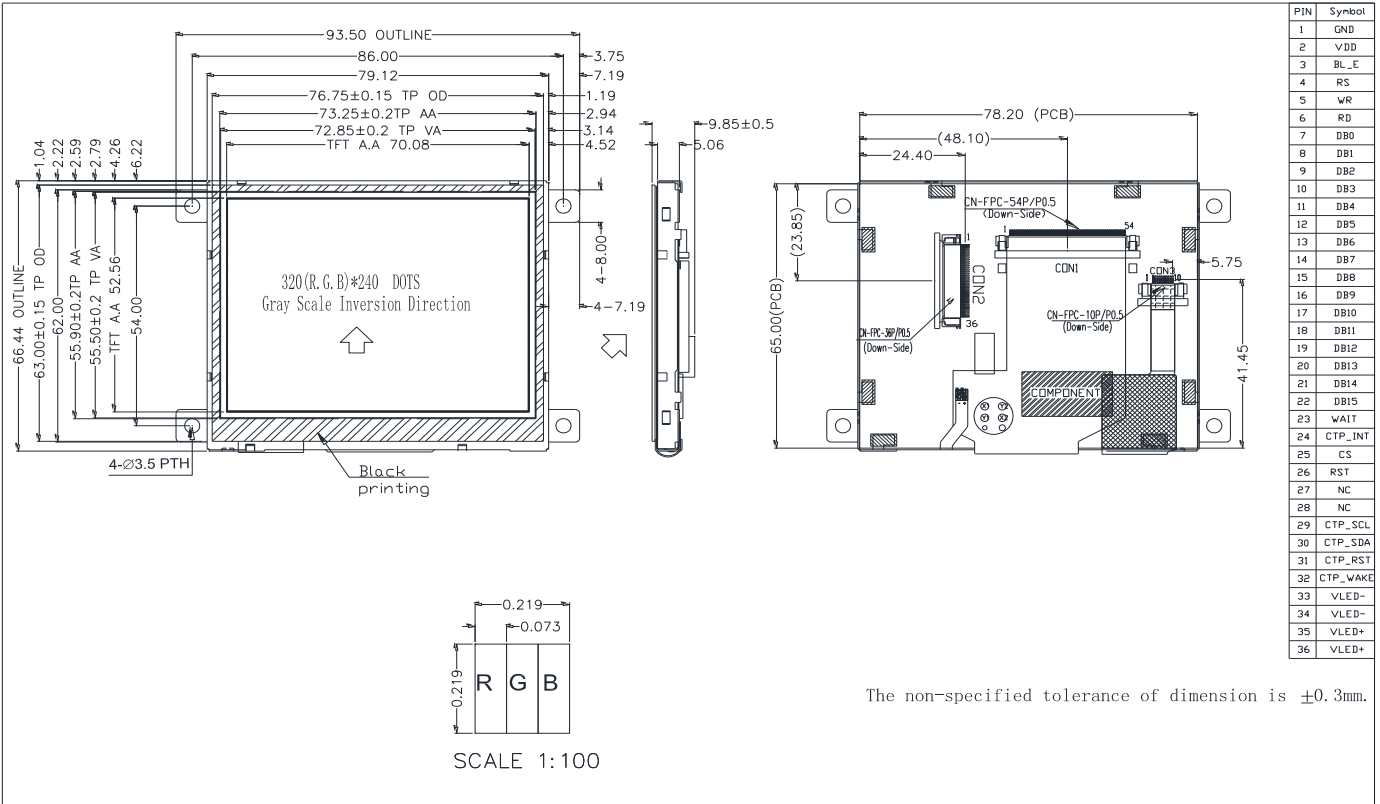

6. Block Diagram

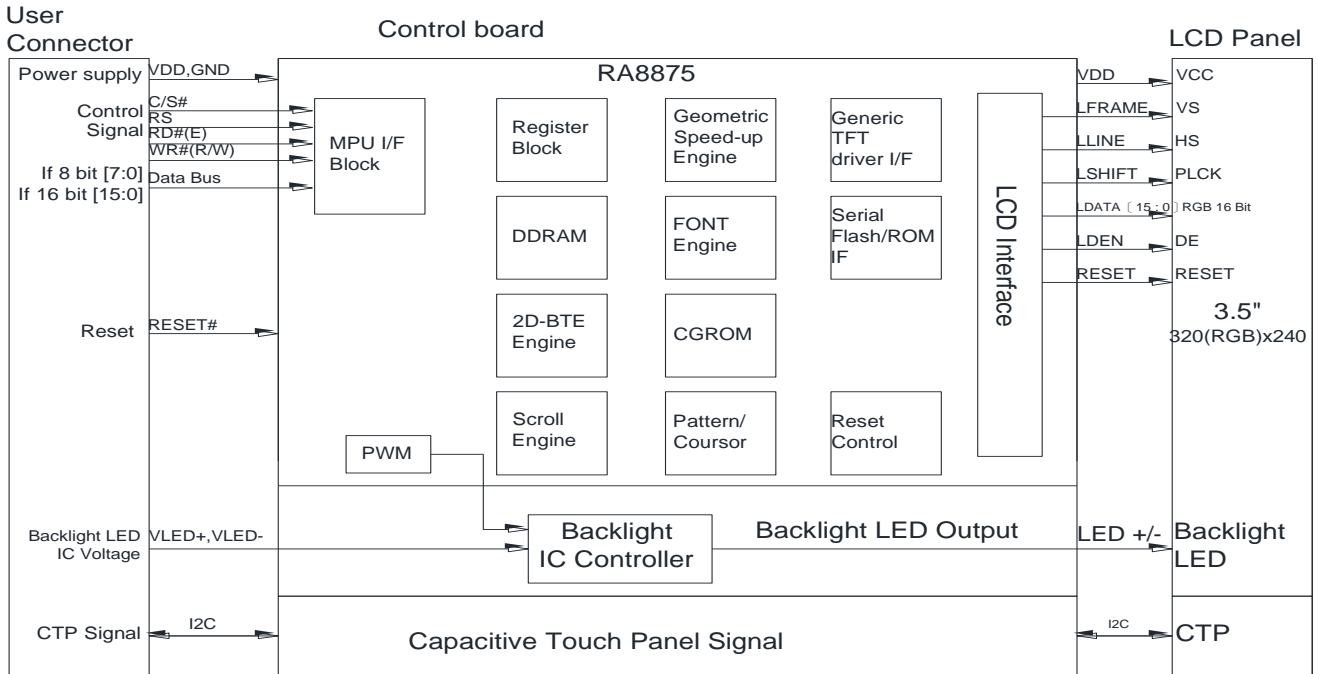

7. Absolute Maximum Ratings

Item	Symbol	Min	Typ	Max	Unit
Operating Temperature	TOP	-20	—	+70	°C
Storage Temperature	TST	-30	—	+80	°C

Note: Device is subject to be damaged permanently if stresses beyond those absolute maximum ratings listed above

- Temp. $\leq 60^{\circ}\text{C}$, 90% RH MAX. Temp. $> 60^{\circ}\text{C}$, Absolute humidity shall be less than 90% RH at 60°C

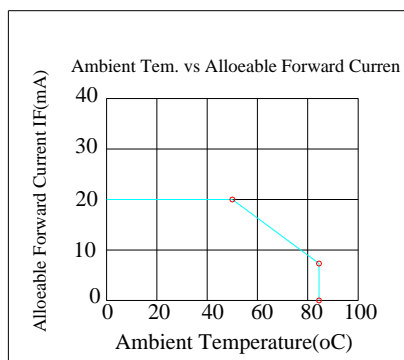

8. Electrical Characteristics

8.1. Operating conditions: (CON2. Pin1=GND, Pin2=VDD)

Item	Symbol	Condition	Min	Typ	Max	Unit	Remark
Supply Voltage For LCM	VDD	-	3.0	3.3	3.6	V	-
Supply Current For LCM	IDD	-	-	50	75	mA	Note1
Power Consumption		-	-	165	270	mW	-

Note 1 : This value is test for VDD only Ta = 25 °C

8.2. LED driving conditions (CON2. Pin33,34=VLED-, Pin35,36=VLED+)

Parameter	Symbol	Min.	Typ.	Max.	Unit	Remark
Operation Current For LED Driver	I _{VLED}	-	-	75	mA	Note 1
Power Consumption	-	-	-	375	mW	VLED=5V
Supply Voltage For LED Driver	VLED+	3.3	-	5	V	Note 1
LED Life Time	-	-	50,000	-	Hr	Note 2,3,4

Note 1 : Power supply the back light IC specification

Note 2 : Ta = 25 °C

Note 3 : Brightness to be decreased to 50% of the initial value

Note 4 : The single LED lamp case

9.DC CHARATERISTICS

Parameter	Symbol	Rating			Unit	Condition
		Min	Typ	Max		
Low level input voltage	VIL	GND	-	0.2 VDD	V	
High level input voltage	VIH	0.8 VDD	-	VDD	V	

10.AC Characteristics

10.1. 8080 Mode

The following timing charts are used to describe the timing specification of the standard 8080 interfaces.

10.2. 8080 Mode Write Cycle

Symbol	Parameter	Rating		Unit	Symbol
		Min.	Max.		
tCYC8	Cycle time	50	-	ns	tc is one system clock period: tc = 1/SYS_CLK
tCC8	Strobe Pulse width	20	-	ns	
tAS8	Address setup time	0	-	ns	
tAH8	Address hold time	10	-	ns	
tDS8	Data setup time	20	-	ns	
tDH8	Data hold time	10	-	ns	
tACC8	Data output access time	0	20	ns	
tOH8	Data output hold time	0	20	ns	

8080 – 8/16-bit interface

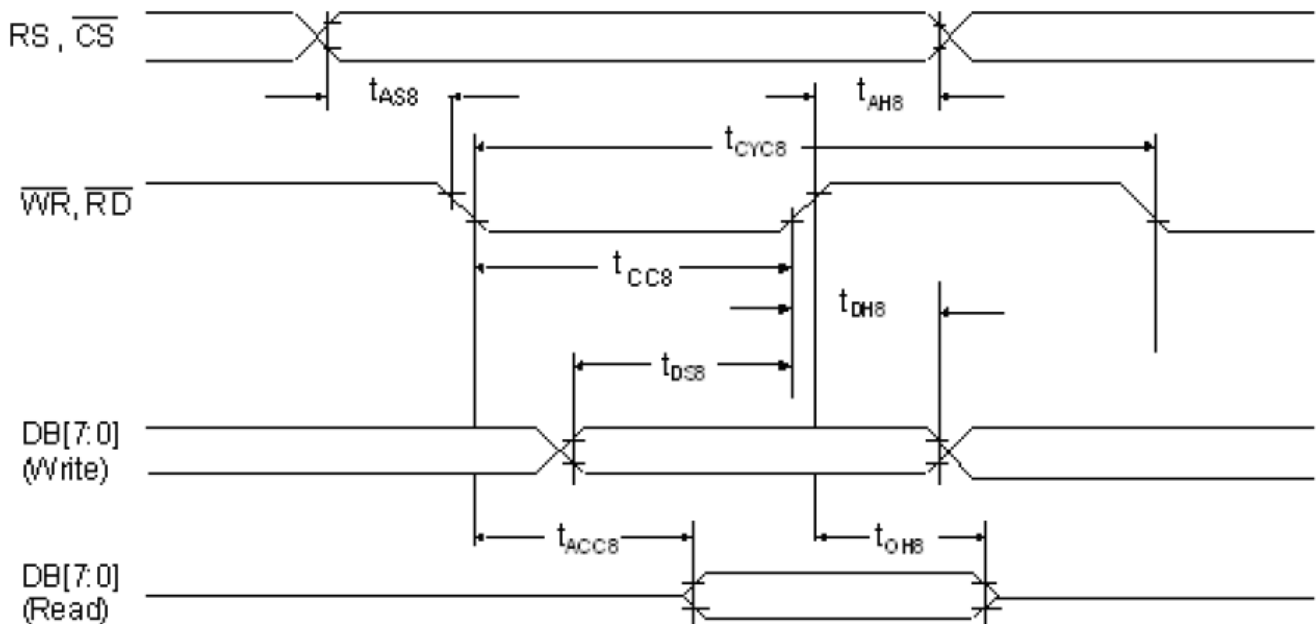

The data bus width of RA8875 can be selected to 8-bit/16-bit by setting the Bit [1:0] of SYSR. When Bit [1:0] of SYSR is cleared to "00", then the data bus is 8-bit. If Bit [1:0] of SYSR is set to "11", then the data transition is set as 16-bit.

10.3. Pixel Data Format
16-bit mode color



65K colors 16-bit

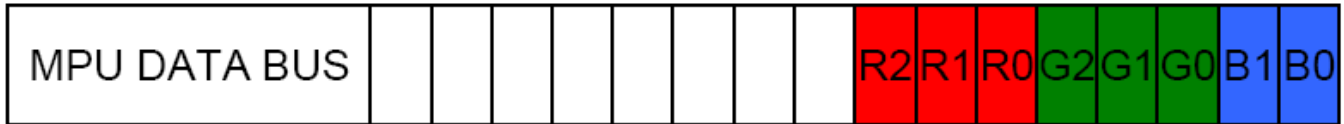

256 colors 16-bit

8-bit mode color



65K colors 8-bit

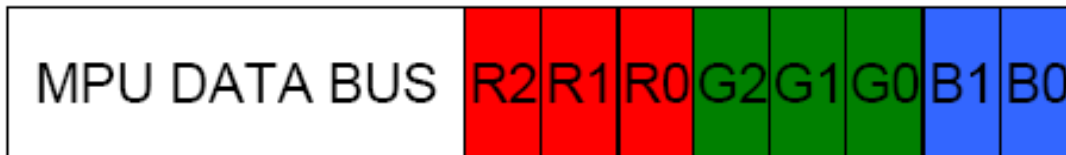

256 colors 8-bit

11. Optical Characteristics

Item	Symbol	Condition.	Min	Typ.	Max.	Unit	Remark	
Response time	Tr	$\theta=0^\circ$ 、 $\phi=0^\circ$	-	10	-	ms	Note	
	Tf		-	15	-	ms	3,5	
Contrast ratio	CR	At optimized viewing angle	300	350	-	-	Note 4,5	
Color Chromaticity	White	Wx	$\theta=0^\circ$ 、 $\phi=0$	0.26	0.31	0.36	-	Note
		Wy		0.28	0.33	0.38	-	2,6,7
Viewing angle (Gray Scale Inversion Direction)	Hor.	θ_R	$CR \geq 10$	-	55	-	Deg.	Note 1
		θ_L		-	55	-		
	Ver.	ϕ_T		-	45	-		
		ϕ_B		-	50	-		
Brightness	-	-	280	340	-	cd/ m ²	Center of display	

Ta=25±2°C, VLED=3.3V

Note 1: Definition of viewing angle range

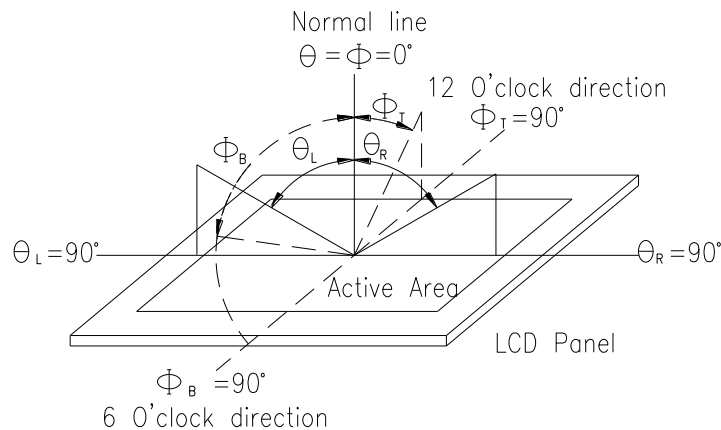

Fig. 11.1. Definition of viewing angle

Note 2: Test equipment setup:

After stabilizing and leaving the panel alone at a driven temperature for 10 minutes, the measurement should be executed. Measurement should be executed in a stable, windless, and dark room. Optical specifications are measured by Topcon BM-7orBM-5 luminance meter 1.0° field of view at a distance of 50cm and normal direction.

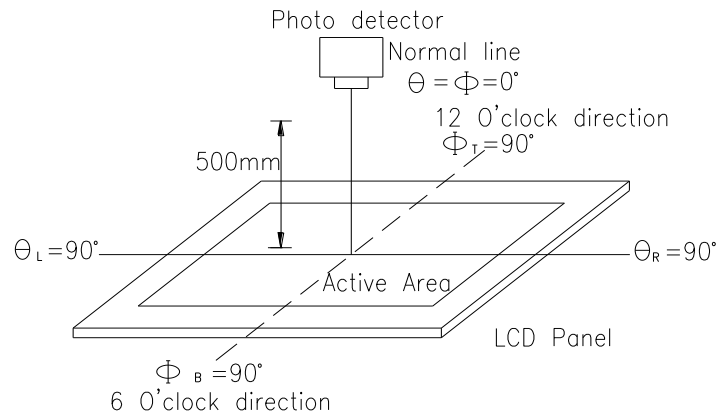
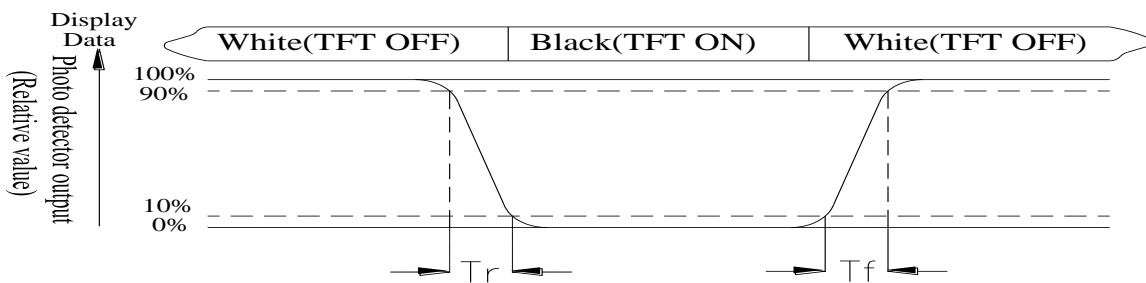

Fig. 11.2. Optical measurement system setup

Note 3: Definition of Response time:

The response time is defined as the LCD optical switching time interval between “White” state and “Black” state. Rise time, T_r , is the time between photo detector output intensity changed from 90% to 10%. And fall time, T_f , is the time between photo detector output intensity changed from 10% to 90%



Note 4: Definition of contrast ratio:

The contrast ratio is defined as the following expression.

$$\text{Contrast ratio (CR)} = \frac{\text{Luminance measured when LCD on the "White" state}}{\text{Luminance measured when LCD on the "Black" state}}$$

Note 5: White $V_i = V_{i50} \pm 1.5V$

Black $V_i = V_{i50} \pm 2.0V$

“±” means that the analog input signal swings in phase with VCOM signal.

“±” means that the analog input signal swings out of phase with VCOM signal.

The 100% transmission is defined as the transmission of LCD panel when all the input terminals of module are electrically opened.

Note 6: Definition of color chromaticity (CIE 1931)

Color coordinates measured at the center point of LCD

Note 7: Measured at the center area of the panel when all the input terminals of LCD panel are electrically opened.

12. Reliability

Content of Reliability Test (Wide temperature, -20°C~70°C)

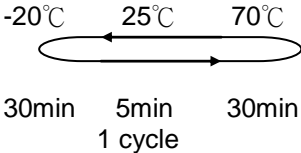
Environmental Test			
Test Item	Content of Test	Test Condition	Note
High Temperature storage	Endurance test applying the high storage temperature for a long time.	80°C 200hrs	2
Low Temperature storage	Endurance test applying the low storage temperature for a long time.	-30°C 200hrs	1,2
High Temperature Operation	Endurance test applying the electric stress (Voltage & Current) and the thermal stress to the element for a long time.	70°C 200hrs	—
Low Temperature Operation	Endurance test applying the electric stress under low temperature for a long time.	-20°C 200hrs	1
High Temperature/ Humidity Operation	The module should be allowed to stand at 60°C,90%RH max	60°C,90%RH 96hrs	1,2
Thermal shock resistance	The sample should be allowed stand the following 10 cycles of operation <div style="text-align: center;">  <p>-20°C 25°C 70°C</p> <p>30min 5min 30min</p> <p>1 cycle</p> </div>	-20°C/70°C 10 cycles	—
Vibration test	Endurance test applying the vibration during transportation and using.	Total fixed amplitude : 3 1.5mm Vibration Frequency : 10~55Hz One cycle 60 seconds to 3 directions of X,Y,Z for Each 15 minutes	3
Static electricity test	Endurance test applying the electric stress to the terminal.	VS=±600V(contact) ,±800v(air), RS=330Ω CS=150pF 10 times	—

Note1: No dew condensation to be observed.

Note2: The function test shall be conducted after 4 hours storage at the normal Temperature and humidity after remove from the test chamber.

Note3: The packing have to including into the vibration testing.

13.Touch Panel Information

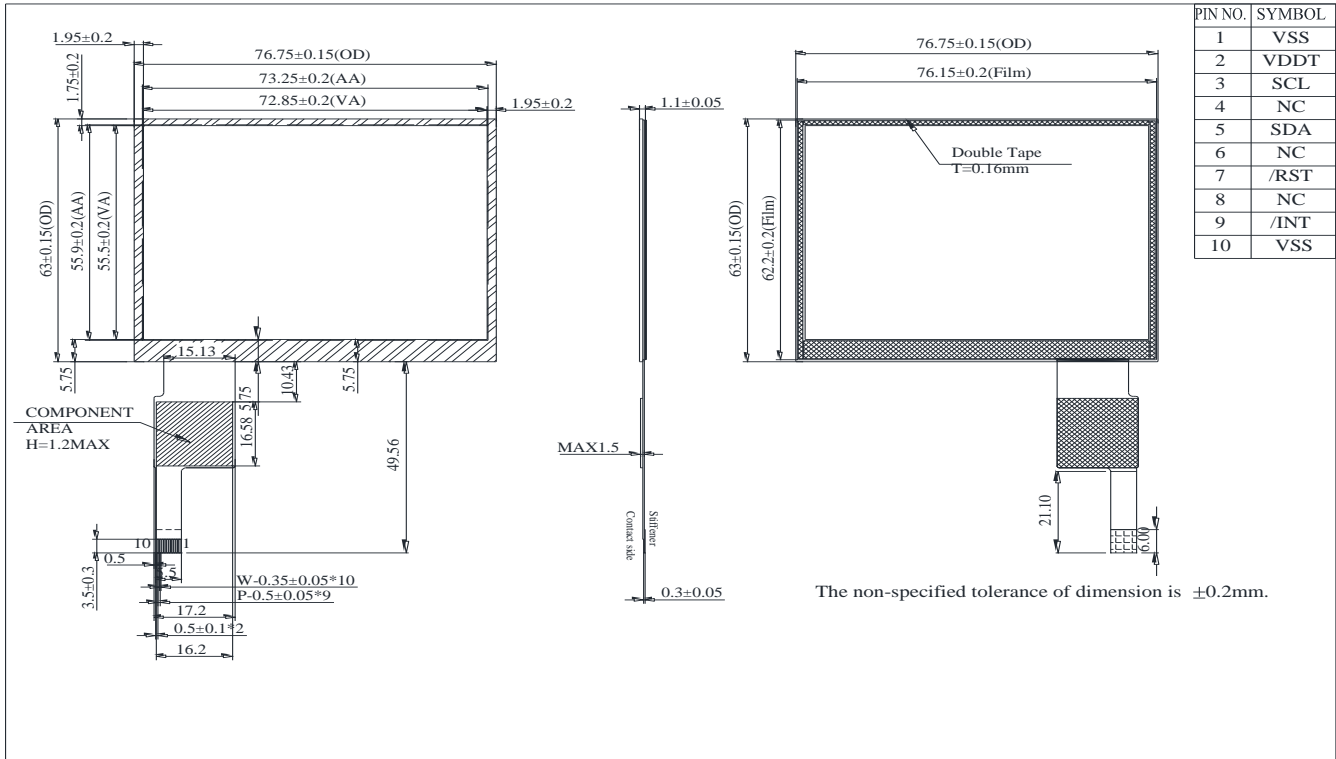

13.1. CTP I2C Timing:

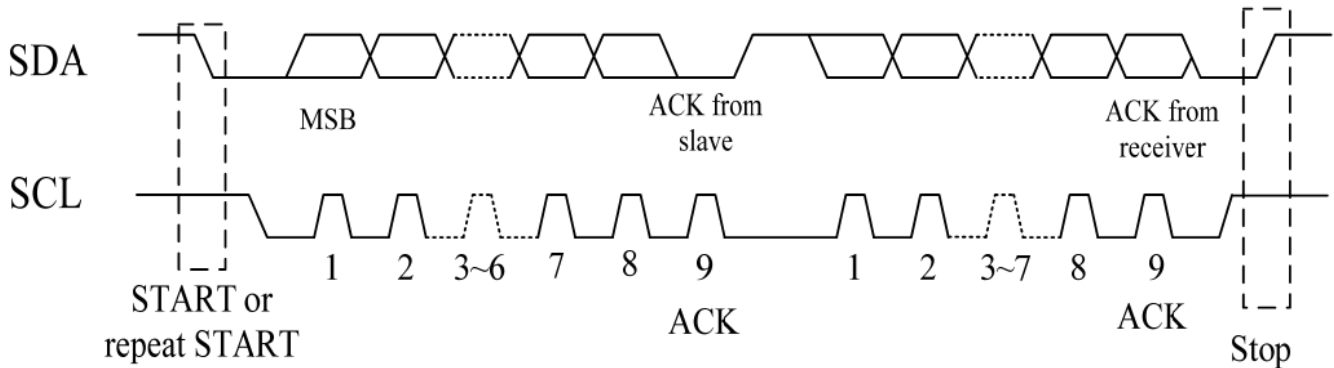

I2C Serial Data Transfer Format

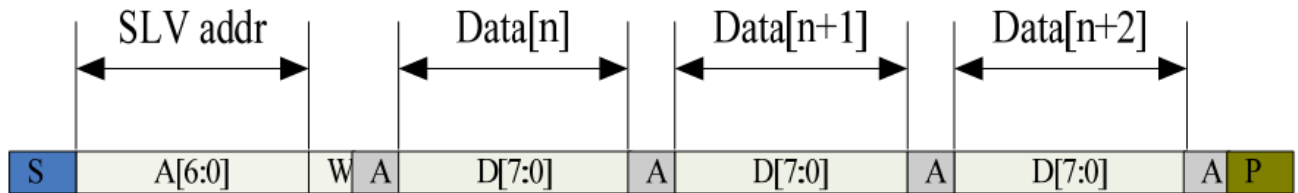

I2C master write, slave read

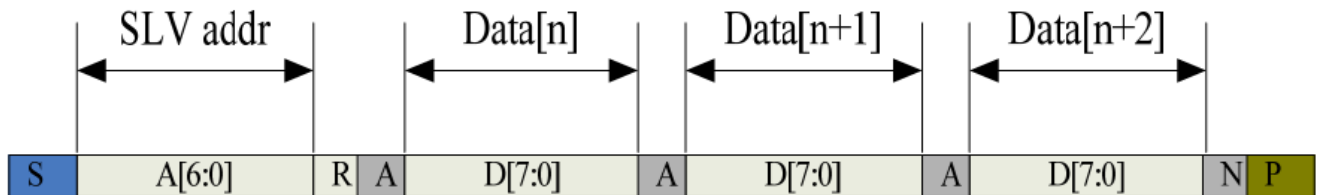

I2C master read, slave write

Mnemonics	Description
S	12C Start or 12C Restart
A[6:0]	Slave address A[6:4]:3'b011 A[3:0]:data bits are identical to those of 12CCON[7:4]register
W	1'b0:Write
R	1'b1:Read
A(N)	ACK(NACK)
P	STOP :the indication of the end of a packet(if this bit is missing, S will indicate the end of the current packet and beginning of the next packet)

Lists the meanings of the mnemonics used in the above figures

Parameter	Unit	Min	Max
SCL frequency	KHz	0	400
Bus free time between a STOP and START condition	us	4.7	\
Hold time (repeated) ST ART condition	us	4.0	\
Data setup time	ns	250	\
Setup time for a repeated START condition	us	4.7	\
Setup time for STOP condition	us	4.0	\

Interface Timing Characteristics

AS FOR STANDARD CTPM, HOST NEED TO USE BOTH INTERRUPT CONTROL SIGNAL AND SERIAL DATA INTERFACE TO GET THE TOUCH DATA.

HERE IS THE TIMING TO GET TOUCH DATA.

13.2. WRITE BYTES TO I2C SLAVE

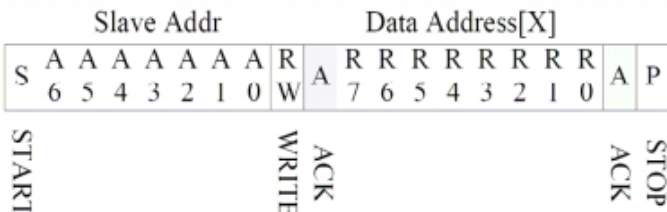
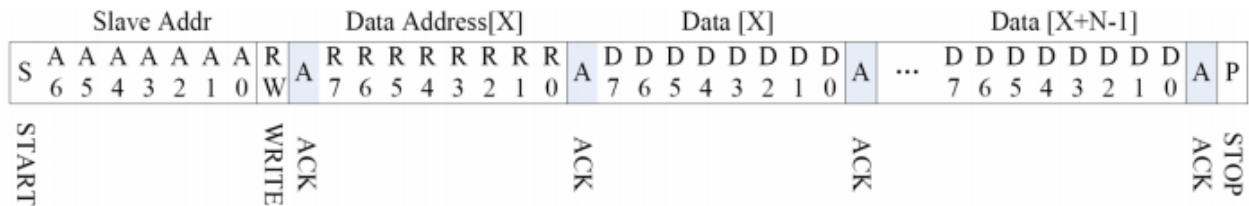

READ X BYTES FROM I2C SLAVE

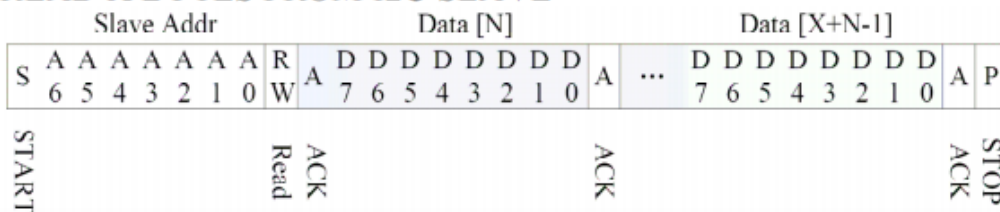

AS FOR STANDARD CTPM, HOST NEED TO USE BOTH INTERRUPT CONTROL SIGNAL AND SERIAL DATA INTERFACE TO GET THE TOUCH DATA, HERE IS THE TIMING TO GET TOUCH DATA.

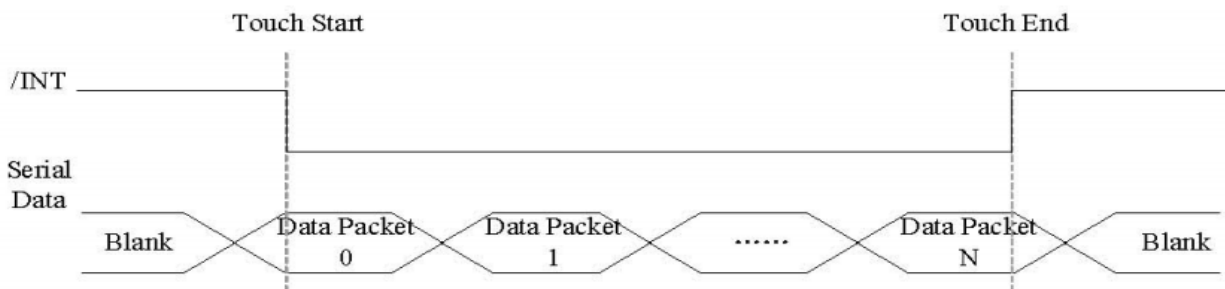

Address: 0x38

TOUCH DATA READ PROTOCOL

NAME	VALUE	DESCRIPTION
START CH	0X00	START COMMAND FOR CTPM TOUCH DATA PACKET,HOST MUST SEND CTPM A START CH COMMAND BEFORE READ TOUCH DATA
1st READ BYTE ~ LAST READ BYTE		TOUCH DATA PACKET SENT BY CTPM,EACH BYTE HAS 8-BIT DATA ,A TOUCH DATA PACKET CONSISTS OF N BYTE

A DATA PACKET STARTS WITH A HEADER AND ENDS WITH CRC CODE,AS FOR 5 POINTS DATA PACKET,THE LENGTH OF THE PACKET IS ALWAYS 26 BYTES IN SPITE OF ACTUAL TOUCH POINTS.

Address	Name	Bit7	Bit6	Bit5	Bit4	Bit3	Bit2	Bit1	Bit0	Host Access
00h	Devide__Mode		Device Model[2:0]							RW
01h	Gest__ID	Gesture ID[7:0]								R
02h	TD__Status					Number of touch points[3:0]				R
03h	Touch1__XH	1 st Event Flag				1 st Touch X Position[11:8]				R
04h	Touch1__XL	1 st Touch X Position[7:0]								R
05h	Touch1__YH	1 st Touch ID[3:0]				1 st Touch Y Position[11:8]				R
06h	Touch1__YL	1 st Touch Y Position[7:0]								R
09h	Touch2__XH	2 nd Event Flag				2 nd Touch X Position[11:8]				R
0Ah	Touch2__XL	2 nd Touch X Position[7:0]								R
0Bh	Touch2__YH	2nd Touch ID[3:0]				2ndTouch Y Position[11:8]				R
0Ch	Touch2__YL	2nd Touch Y Position[7:0]								R

0Fh	Touch3__XH	3rdEvent Flag		3rdTouch X Position[11:8]	R
10h	Touch3__XL	3rd Touch X Position[7:0]			R
11h	Touch3__YH	3rdTouch ID[3:0]		3rdTouch Y Position[11:8]	R
12h	Touch3__YL	3rd Touch Y Position[7:0]			R
15h	Touch4__XH	4thEvent Flag		4thTouch X Position[11:8]	R
16h	Touch4__XL	4th Touch X Position[7:0]			R
17h	Touch4__YH	4thTouch ID[3:0]		4thTouch Y Position[11:8]	R
18h	Touch4__YL	4th Touch Y Position[7:0]			R
1Bh	Touch5__XH	5thEvent Flag		5thTouch X Position[11:8]	R
1Ch	Touch5__XL	5th Touch X Position[7:0]			R
1Dh	Touch5__YH	5thTouch ID[3:0]		5thTouch Y Position[11:8]	R
1Eh	Touch5__YL	5th Touch Y Position[7:0]			R

14.PACKAGE SPECIFICATION

<table border="1" style="width: 100%; border-collapse: collapse;"> <tr> <td style="width: 50%;">LCM Model</td> <td>RFC350P-EIW-DBC</td> </tr> <tr> <td>Drawing NO.</td> <td></td> </tr> </table>	LCM Model	RFC350P-EIW-DBC	Drawing NO.		<p style="font-size: 24px; font-weight: bold;">LCM 包裝規格書</p> <p style="font-size: 18px; font-weight: bold;">LCM Packaging Specifications</p>	<table border="1" style="width: 100%; border-collapse: collapse;"> <tr> <td style="width: 33%;">Approve</td> <td style="width: 33%;">Check</td> <td style="width: 33%;">Contact</td> </tr> <tr> <td> </td> <td> </td> <td> </td> </tr> <tr> <td>DATE</td> <td>初版</td> <td>版次 Ver</td> </tr> <tr> <td>02/05/14'</td> <td>02/05/14'</td> <td>0</td> </tr> </table>	Approve	Check	Contact				DATE	初版	版次 Ver	02/05/14'	02/05/14'	0																																		
LCM Model	RFC350P-EIW-DBC																																																			
Drawing NO.																																																				
Approve	Check	Contact																																																		
DATE	初版	版次 Ver																																																		
02/05/14'	02/05/14'	0																																																		
<p>1.包裝材料規格表 (Packaging Material) :(per carton)</p> <table border="1" style="width: 100%; border-collapse: collapse;"> <thead> <tr> <th style="width: 5%;">NO.</th> <th style="width: 30%;">Item</th> <th style="width: 30%;">Model</th> <th style="width: 20%;">Dimensions</th> <th style="width: 15%;">Quantity</th> </tr> </thead> <tbody> <tr> <td>1</td> <td>成品 (LCM)</td> <td>RFC350P-EIW-DBC</td> <td></td> <td style="text-align: center;">216</td> </tr> <tr> <td>2</td> <td>TRAY 盤 (2)</td> <td>PKCA1XXXXXXXXXXXX0355</td> <td style="text-align: center;">315*265mm</td> <td style="text-align: center;">36</td> </tr> <tr> <td>3</td> <td>BP01 內盒(3)Product Box</td> <td>PK3Y1XXXXXXXXXXXX0001</td> <td style="text-align: center;">332*280*100mm</td> <td style="text-align: center;">6</td> </tr> <tr> <td>4</td> <td>泡棉(4)Foam</td> <td style="text-align: center;">-----</td> <td style="text-align: center;">-</td> <td style="text-align: center;">6</td> </tr> <tr> <td>5</td> <td>外紙箱(5)Carton</td> <td>PK4X1XXXXXXXXXXXX0000</td> <td style="text-align: center;">565*340*320mm</td> <td style="text-align: center;">1</td> </tr> <tr> <td>6</td> <td> </td> <td> </td> <td> </td> <td> </td> </tr> <tr> <td>7</td> <td> </td> <td> </td> <td> </td> <td> </td> </tr> <tr> <td>8</td> <td> </td> <td> </td> <td> </td> <td> </td> </tr> <tr> <td>9</td> <td> </td> <td> </td> <td> </td> <td> </td> </tr> </tbody> </table>			NO.	Item	Model	Dimensions	Quantity	1	成品 (LCM)	RFC350P-EIW-DBC		216	2	TRAY 盤 (2)	PKCA1XXXXXXXXXXXX0355	315*265mm	36	3	BP01 內盒(3)Product Box	PK3Y1XXXXXXXXXXXX0001	332*280*100mm	6	4	泡棉(4)Foam	-----	-	6	5	外紙箱(5)Carton	PK4X1XXXXXXXXXXXX0000	565*340*320mm	1	6					7					8					9				
NO.	Item	Model	Dimensions	Quantity																																																
1	成品 (LCM)	RFC350P-EIW-DBC		216																																																
2	TRAY 盤 (2)	PKCA1XXXXXXXXXXXX0355	315*265mm	36																																																
3	BP01 內盒(3)Product Box	PK3Y1XXXXXXXXXXXX0001	332*280*100mm	6																																																
4	泡棉(4)Foam	-----	-	6																																																
5	外紙箱(5)Carton	PK4X1XXXXXXXXXXXX0000	565*340*320mm	1																																																
6																																																				
7																																																				
8																																																				
9																																																				
<p>2.單箱數量規格表(Packaging Specifications and Quantity) :</p> <p>(1)LCM quantity per box : no per tray 6 x no of tray 6 = 36</p> <p>(2)Total LCM quantity in carton : quantity per box 36 x no of boxes 6 = 216</p>																																																				
<p>特 記 事 項 (REMARK)</p>																																																				
<p>1. Label Specifications :</p> <table border="1" style="width: 100%; border-collapse: collapse;"> <tr> <td style="padding: 5px;"> MOOEL: LOT NO : QUANTITY: CHECK: </td> </tr> </table>	MOOEL: LOT NO : QUANTITY: CHECK:																																																			
MOOEL: LOT NO : QUANTITY: CHECK:																																																				

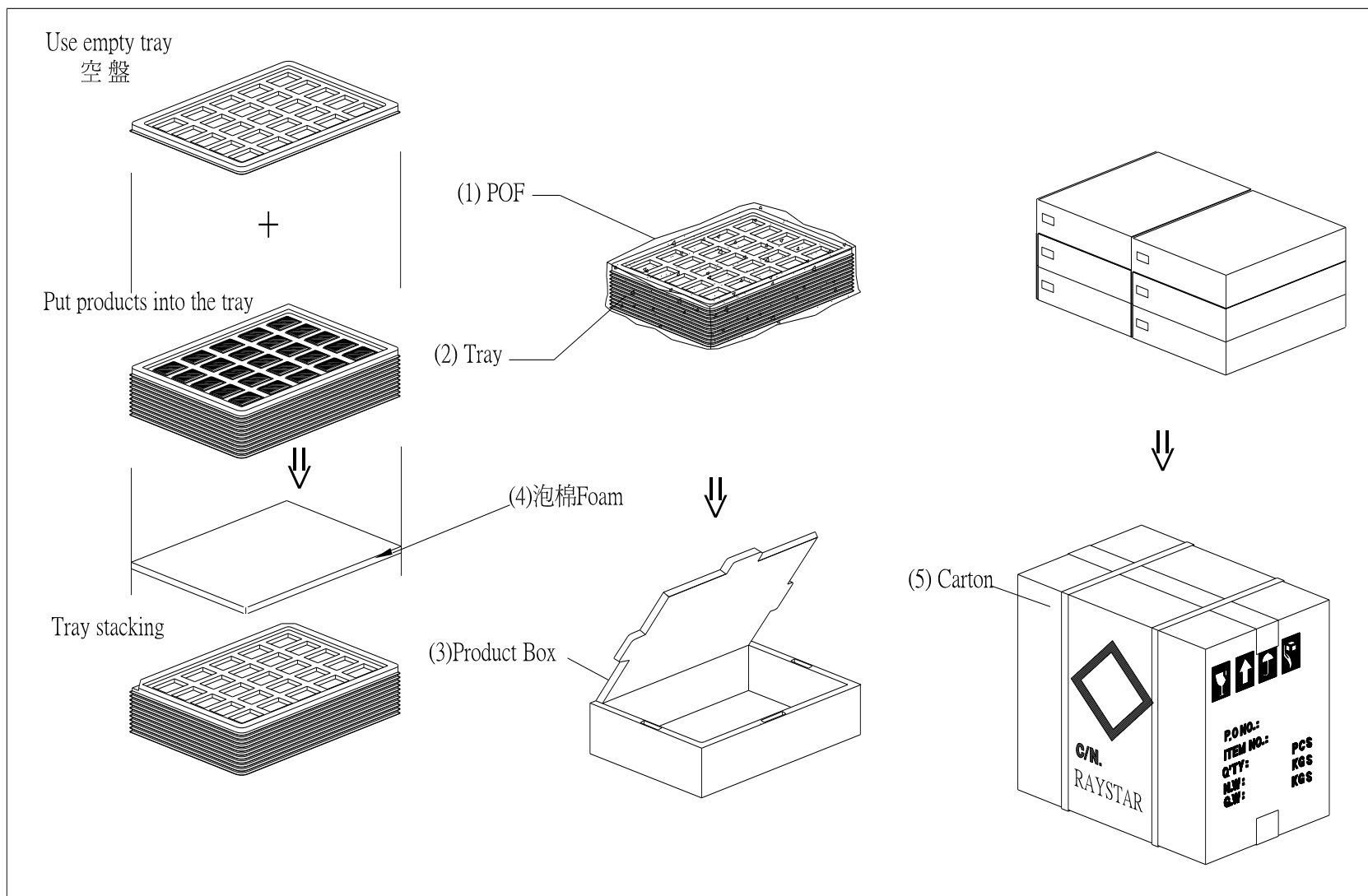

15.Initial Code For Reference

```
void Initial_RA8875()
{
    RES = 1;
    Delay1ms (10);
    RES = 0;
    Delay1ms (50);
    RES = 1;
    Delay1ms (100);

    LCD_CmdWrite(0x88);
    LCD_DataWrite(0x0a);
    Delay1ms(1);
    LCD_CmdWrite(0x89);
    LCD_DataWrite(0x02);
    Delay1ms(1);

    LCD_CmdWrite(0x10);
    LCD_DataWrite(0x0c);

    LCD_CmdWrite(0x04);
    LCD_DataWrite(0x03);
    Delay1ms(1);

    //Horizontal set
    LCD_CmdWrite(0x14);
    LCD_DataWrite(0x27);
    LCD_CmdWrite(0x15);
    LCD_DataWrite(0x80);
    LCD_CmdWrite(0x16);
    LCD_DataWrite(0x03);
    LCD_CmdWrite(0x17);
    LCD_DataWrite(0x02);
    LCD_CmdWrite(0x18);
    LCD_DataWrite(0x03);

    LCD_CmdWrite(0x19);
    LCD_DataWrite(0xef);
    LCD_CmdWrite(0x1A);
    LCD_DataWrite(0x00);
    LCD_CmdWrite(0x1B);
    LCD_DataWrite(0x0f);
    LCD_CmdWrite(0x1C);
    LCD_DataWrite(0x00);
    LCD_CmdWrite(0x1D);
    LCD_DataWrite(0x0e);
    LCD_CmdWrite(0x1E);
    LCD_DataWrite(0x06);
}
```

```
LCD_CmdWrite(0x1F);  
LCD_DataWrite(0x01);
```

```
LCD_CmdWrite(0x30);  
LCD_DataWrite(0x00);  
LCD_CmdWrite(0x31);  
LCD_DataWrite(0x00);  
LCD_CmdWrite(0x34);  
LCD_DataWrite(0x3F);  
LCD_CmdWrite(0x35);  
LCD_DataWrite(0x01);
```

```
LCD_CmdWrite(0x32);  
LCD_DataWrite(0x00);  
LCD_CmdWrite(0x33);  
LCD_DataWrite(0x00);  
LCD_CmdWrite(0x36);  
LCD_DataWrite(0xef);  
LCD_CmdWrite(0x37);  
LCD_DataWrite(0x00);
```

```
}
```

LCM Sample Estimate Feedback Sheet

Module Number : _____

1 、 Panel Specification :

1. Panel Type :	<input type="checkbox"/> Pass	<input type="checkbox"/> NG , _____
2. View Direction :	<input type="checkbox"/> Pass	<input type="checkbox"/> NG , _____
3. Numbers of Dots :	<input type="checkbox"/> Pass	<input type="checkbox"/> NG , _____
4. View Area :	<input type="checkbox"/> Pass	<input type="checkbox"/> NG , _____
5. Active Area :	<input type="checkbox"/> Pass	<input type="checkbox"/> NG , _____
6. Operating Temperature :	<input type="checkbox"/> Pass	<input type="checkbox"/> NG , _____
7. Storage Temperature :	<input type="checkbox"/> Pass	<input type="checkbox"/> NG , _____
8. Others : _____		

2 、 Mechanical Specification :

1. PCB Size :	<input type="checkbox"/> Pass	<input type="checkbox"/> NG , _____
2. Frame Size :	<input type="checkbox"/> Pass	<input type="checkbox"/> NG , _____
3. Material of Frame :	<input type="checkbox"/> Pass	<input type="checkbox"/> NG , _____
4. Connector Position :	<input type="checkbox"/> Pass	<input type="checkbox"/> NG , _____
5. Fix Hole Position :	<input type="checkbox"/> Pass	<input type="checkbox"/> NG , _____
6. Backlight Position :	<input type="checkbox"/> Pass	<input type="checkbox"/> NG , _____
7. Thickness of PCB :	<input type="checkbox"/> Pass	<input type="checkbox"/> NG , _____
8. Height of Frame to PCB :	<input type="checkbox"/> Pass	<input type="checkbox"/> NG , _____
9. Height of Module :	<input type="checkbox"/> Pass	<input type="checkbox"/> NG , _____
10. Others :	<input type="checkbox"/> Pass	<input type="checkbox"/> NG , _____

3 、 Relative Hole Size :

1. Pitch of Connector :	<input type="checkbox"/> Pass	<input type="checkbox"/> NG , _____
2. Hole size of Connector :	<input type="checkbox"/> Pass	<input type="checkbox"/> NG , _____
3. Mounting Hole size :	<input type="checkbox"/> Pass	<input type="checkbox"/> NG , _____
4. Mounting Hole Type :	<input type="checkbox"/> Pass	<input type="checkbox"/> NG , _____
5. Others :	<input type="checkbox"/> Pass	<input type="checkbox"/> NG , _____

4 、 Backlight Specification :

1. B/L Type :	<input type="checkbox"/> Pass	<input type="checkbox"/> NG , _____
2. B/L Color :	<input type="checkbox"/> Pass	<input type="checkbox"/> NG , _____
3. B/L Driving Voltage (Reference for LED Type) : <input type="checkbox"/> Pass <input type="checkbox"/> NG , _____		
4. B/L Driving Current :	<input type="checkbox"/> Pass	<input type="checkbox"/> NG , _____
5. Brightness of B/L :	<input type="checkbox"/> Pass	<input type="checkbox"/> NG , _____
6. B/L Solder Method :	<input type="checkbox"/> Pass	<input type="checkbox"/> NG , _____
7. Others :	<input type="checkbox"/> Pass	<input type="checkbox"/> NG , _____

>> **Go to page 2** <<

Module Number : _____		
5 · <u>Electronic Characteristics of Module</u> :		
1.Input Voltage :	<input type="checkbox"/> Pass	<input type="checkbox"/> NG , _____
2.Supply Current :	<input type="checkbox"/> Pass	<input type="checkbox"/> NG , _____
3.Driving Voltage for LCD :	<input type="checkbox"/> Pass	<input type="checkbox"/> NG , _____
4.Contrast for LCD :	<input type="checkbox"/> Pass	<input type="checkbox"/> NG , _____
5.B/L Driving Method :	<input type="checkbox"/> Pass	<input type="checkbox"/> NG , _____
6.Negative Voltage Output :	<input type="checkbox"/> Pass	<input type="checkbox"/> NG , _____
7.Interface Function :	<input type="checkbox"/> Pass	<input type="checkbox"/> NG , _____
8.LCD Uniformity :	<input type="checkbox"/> Pass	<input type="checkbox"/> NG , _____
9.ESD test :	<input type="checkbox"/> Pass	<input type="checkbox"/> NG , _____
10.Others :	<input type="checkbox"/> Pass	<input type="checkbox"/> NG , _____
6 · <u>Summary</u> :		
<p>Sales signature : _____</p> <p>Customer Signature : _____ Date : / / _____</p>		