

# HK 0810

## Dimensions

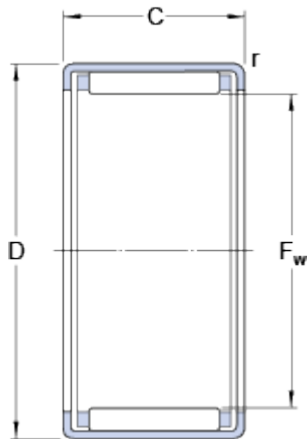

$F_w$	<b>8</b>	mm
D	<b>12</b>	mm
C	<b>10</b>	mm
r	min. <b>0.4</b>	mm

## Calculation data

Basic dynamic load rating	C	<b>3.69</b>	kN
Basic static load rating	$C_0$	<b>4.05</b>	kN
Fatigue load limit	$P_u$	<b>0.44</b>	kN
Reference speed		<b>19000</b>	r/min
Limiting speed		<b>22000</b>	r/min

## Mass

Mass bearing	<b>0.003</b>	kg
--------------	--------------	----

Designation	<b>HK 0810</b>
-------------	----------------

## Associated products

Inner ring IR series	IR 5 x 8 x 12
Radial shaft seal with a low cross-sectional height, single lip	G 8x12x3