

HK 1010

Dimensions

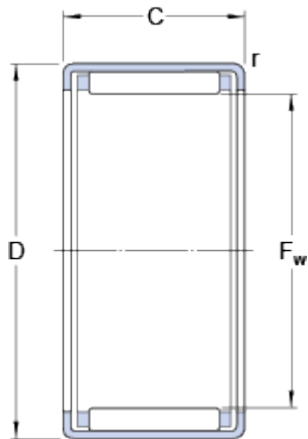

F_w	10	mm
D	14	mm
C	10	mm
r	min. 0.4	mm

Calculation data

Basic dynamic load rating	C	4.29	kN
Basic static load rating	C_0	5.3	kN
Fatigue load limit	P_u	0.57	kN
Reference speed		18000	r/min
Limiting speed		20000	r/min

Mass

Mass bearing	0.0041	kg
--------------	---------------	----

Designation	HK 1010
-------------	----------------

Associated products

Inner ring IR series	IR 7 x 10 x 10.5
Inner ring LR series	LR 7 x 10 x 10.5
Radial shaft seal with a low cross-sectional height, single lip	G 10x14x3