

UNIVERSAL MOTOR PROTECTION UNIT UBZ-305

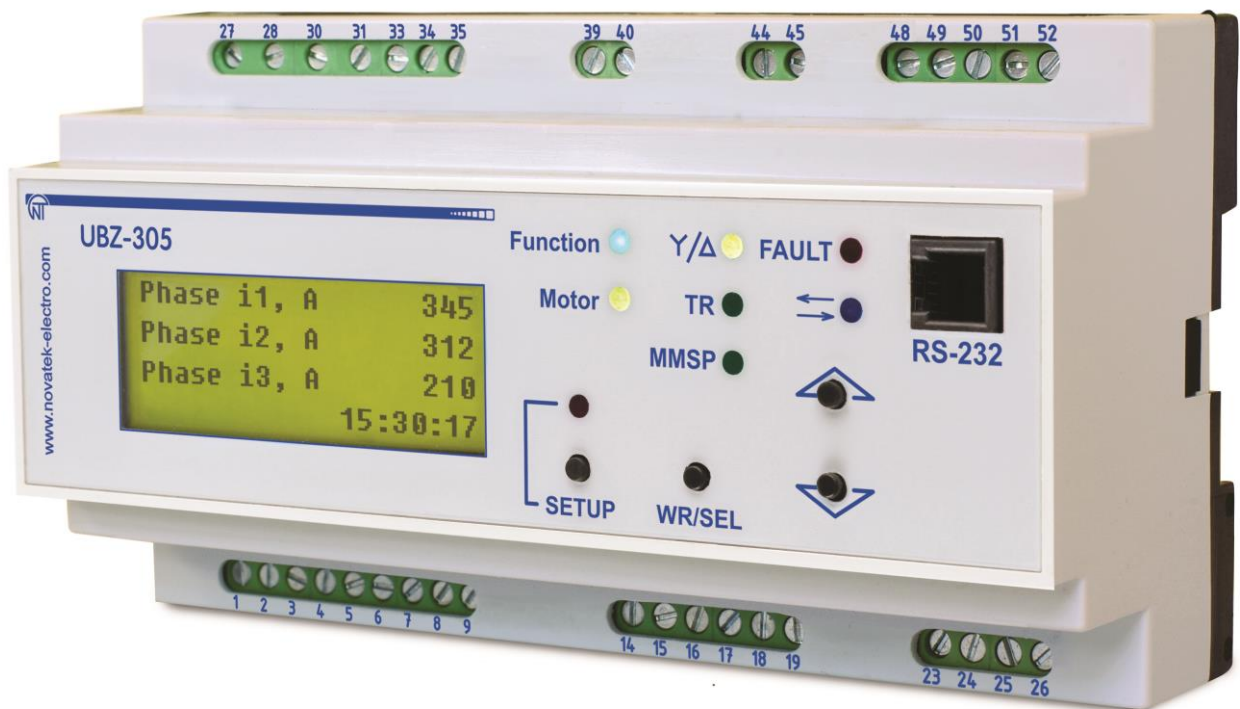

OPERATION MANUAL TECHNICAL PASSPORT

1 APPLICATION	4
1.1 General	4
1.2 Operating conditions	5
1.3 Changes in the characteristics and operation of UBZ depending on program version	5
1.4 Controls and overall dimensions	5
1.4.1 Design	5
1.4.2 Displays and controls	6
2 SPECIFICATIONS	7
2.1 Basic technical specifications	7
2.2 Measured, calculated, special and service parameters	8
2.3 Programmable parameters	10
2.4 Protection functions	16
2.4.1 Protection types	16
2.4.2 Maximum phase current protection	17
2.4.3 Ground fault protection	17
2.4.4 Negative-sequence current protection (imbalance)	17
2.4.5 Minimum phase current protection	18
2.4.6 Delayed start and rotor blocking	18
2.4.7 Thermal overload protection	19
2.4.8 Windings overheating protection	19
2.4.9 Voltage protection	20
2.4.10 Phase sequence protection	20
2.4.11 Network power frequency drop protection	20
2.4.12 Network power frequency rise protection	20
2.4.13 Protection for minimum resistance of motor winding insulation	20
2.4.14 Protection for motor phase (-s) break (loss)	20
2.4.15 Serviceability check of external magnetic starter	20
2.5 Selection of current transformers	20
3 UBZ DESIGN	21
4 SAFETY PRECAUTIONS	21
5 INTENDED USE	21
5.1 Safety precautions	21
5.2 UBZ preparation for use	21
5.3 UBZ control	23
5.3.1 Modes of UBZ control and status	23
5.3.2 Measured and calculated parameters view state	24
5.3.3 Mode of keyboard blocking	24
5.3.4 Mode of minimum number of settings	25
5.3.5 Mode of user level	25
5.3.6 Mode of advanced user level	26
5.3.7 Factory settings	26
5.3.8 Current time setting	26
5.3.9 UBZ faults reset on front panel	27
5.3.10 Energy meters reset	27
5.4 UBZ operation	27
5.4.1 UBZ operation before load relay on	27
5.4.2 UBZ operation after load relay and motor on	28
5.4.3 Functional relay operation	28
5.5 Operation of UBZ together with computer	28
5.5.1 Communication protocol and interface	28
5.5.2 Communication parameters	29
5.5.3 Communication protocol	29
5.5.4 Command codes	30
5.5.5 Control of correct transmission of data packet	32
5.5.6 Register addresses	32
5.5.7 Time parameter registers	33
5.5.8 Communication errors handling	33
5.5.9 Remote control of the motor using RS-232/RS-485 interface	34

5.5.10 Command for UBZ FAULTS RESET	35
5.5.11 Command for UBZ RESTART	35
5.5.12 UBZ factory settings using MODBUS interface	35
5.6 Emergency conditions system	35
5.7 Emergency conditions logbook	37
5.8 Motor control on UBZ front panel	37
5.9 Motor control using analog inputs	38
6 COMPONENTS	38
7 MAINTENANCE	38
8 TRANSPORTATION AND STORAGE	38
9 SERVICE LIFE, SHELF LIFE AND MANUFACTURER WARRANTY	38
10 ACCEPTANCE CERTIFICATE	39
11 CLAIMS DATA	39
Appendix A – Current protection with dependent time delay	
Appendix B – UBZ operation for motor control with winding changeover when star-to-delta starting.	

This Operation Manual is intended to familiarize you with the unit, the requirements for safety, operation and maintenance procedures of the universal motor protection unit of **UBZ-305** (hereinafter referred to as UBZ).



ATTENTION!
ALL REQUIREMENTS OF THIS OPERATION MANUAL ARE COMPULSORY TO BE MET!

The product meets the requirements:

UBZ complies with the requirements of the following international standards:

- IEC 60947-1, Low-voltage Switchgear and Control-gear; Part 1: General Rules;
- IEC 60947-6-2:1992, Low-voltage switchgear and control gear – Part 6-2: Multiple function equipment - Control and protective switching devices (or equipment)
- CISPR 11:2004, Industrial, scientific and medical (ISM) radio-frequency equipment - Electromagnetic disturbance characteristics – Limits and methods of measurement
- IEC 61000-4-2:2001, Electromagnetic compatibility (EMC) – Part 4-2: Testing and measurement techniques – Electrostatic discharge immunity test

Note: The product characteristics comply with both international standards and corresponding national standards.

Harmful substances in amounts exceeding maximum permissible concentrations are not available.

INSTALLATION, ADJUSTMENT AND MAINTENANCE OF THE UNIT SHOULD BE PERFORMED ONLY BY SKILLED PERSONNEL WHO THOROUGHLY STUDIED THIS OPERATION MANUAL.

In compliance with the requirements of this Operation Manual and regulations the product is safe for use.

Abbreviations and terms:

ARS – Automatic restarting;

MS – Magnetic starter;

PC- Personal computer;

CT - Current transformer;

LCD – Liquid crystal display;

MNS - Minimum number of settings (it is used in phrases as MNS mode or MNS list);

I_{ct} - Rated current of CT (it is set when external CTs using; e.g., if CT is of T-0.66 300/5 type, then I_{ct} equals to 300A);

I_n – Rated current of the motor; As a rule, this value of current is indicated on the motor nameplate, but depending on the operating conditions, the different value of current can be set;

s.c. – short circuit.

1 APPLICATION

1.1 General

UBZ is designed for protection of induction motors with power of 2.5 to 315 kW in case of using the external standard current transformers with 5A output current.

UBZ can be operated in networks both with insulated and dead grounded neutral.

The unit is of DIN rail design version.

UBZ provides continuous monitoring of mains voltage parameters, **current** values of the phase (line) currents of three-phase electrical equipment for 380V, 50Hz, and checking the resistance values of motor insulation.

UBZ provides protection of electrical motors in case of:

- low-quality network voltage (unacceptable power surges, phase failure, incorrect phase sequence and phase "coincidence", the imbalance of phase/line voltages, the reduction in the network frequency lower than the set one and (or) the increase of network frequency higher than the set value);
- mechanical overloads (symmetrical overload in phase/line currents);
- the threshold crossing of the negative-sequence current;
- unbalance of phase currents without overload associated with the insulation fault inside motor and/or the power cable (the comparison of current unbalance factor according to inverse sequence with voltage unbalance factor according to inverse sequence);
- the torque failure on the motor shaft ("dry running" for pumps) – protection based on the minimum starting and/or operating current;
- motor delayed start or rotor blocking;

- extremely low isolation between the stator and the motor housing (pre-startup check);
- ground fault of the stator winding during operation – ground leakage current protection;
- motor thermal overload;
- overheated windings (temperature of windings is determined using the motor built-in temperature transmitters or the temperature of the housing when using the external temperature transmitters).

For each type of protection it is possible to have banning and permitting of automatic restarting (hereinafter referred to as ARS) with load.

UBZ provides for electric equipment protection by means of controlling the coil of the magnetic starter (contactor).

UBZ detects motor currents when load relay is off (when the load relay is off and functional relay is in star-delta mode). In this case, UBZ indicates the fault of external contactor starting the motor until UBZ is turned off or control of motor currents is disabled when load relay is off.

UBZ provides for electric motors control:

- using analog inputs "0-20 mA" and "0-10 V";
- using remote control channels (RS-232 and RS-485 interfaces);
- by buttons on the front panel of UBZ.

Communication

UBZ provides:

- parameters control and transmission by RS-485 interface using MODBUS Protocol,
- parameters control and transmission by RS-232 interface.

Note: Simultaneous use of RS-485 and RS-232 is not possible.

For UBZ operation with PC the program of UBZ-304/305 Control Panel can be used; it is available on the website of NOVATEK-ELECTRO Company (http://www.novatek-electro.com/production_ubz.htm).

UBZ-304/305 Control Panel program is designed to monitor the status and collect data of the UBZ-305 unit via RS-232 or RS-485 communication interfaces (MODBUS Protocol). The program allows for saving (loading) various UBZ settings, retrieving data and save them for further analysis. Data saved can be viewed in the graphs, comparing the parameters with each other.

Graphic interface of the control panel allows real-time viewing the current status of various UBZ parameters. The flexible adjustment of interface allows adapting to the needs of any user.

1.2 Operating Conditions

UBZ is designed for operation in the following conditions:

- Ambient temperature: from minus 20 to +55°C;
- Atmospheric pressure: from 84 to 106.7 kPa;
- Relative air humidity (at temperature of +25°C): 30 ... 80%.

ATTENTION!

The product is not intended for use:

- in conditions of significant vibration and shocks;
- in high humidity conditions;
- in corrosion environments with content in the air of acids, alkalis, etc., as well as severe contamination (grease, oil, dust, etc.).

If the temperature of the unit after transportation or storage is different from the temperature of the environment in which its operation is assumed, then before connecting to the mains keep the unit in operation conditions for two hours (because on the unit elements condensation may be available).

1.3 Changes in the Characteristics and Operation of UBZ Depending on Program Version

If the software version is 5 or less, then changes in UBZ characteristics and operation are not available.

Version 7: metering of total, active and reactive energies is added.

Version 8: integrity control of voltages and currents calibration factors is added.

1.4 Controls and Overall Dimensions

1.4.1. Design

Overall dimensions of UBZ are given in Fig.1.1.

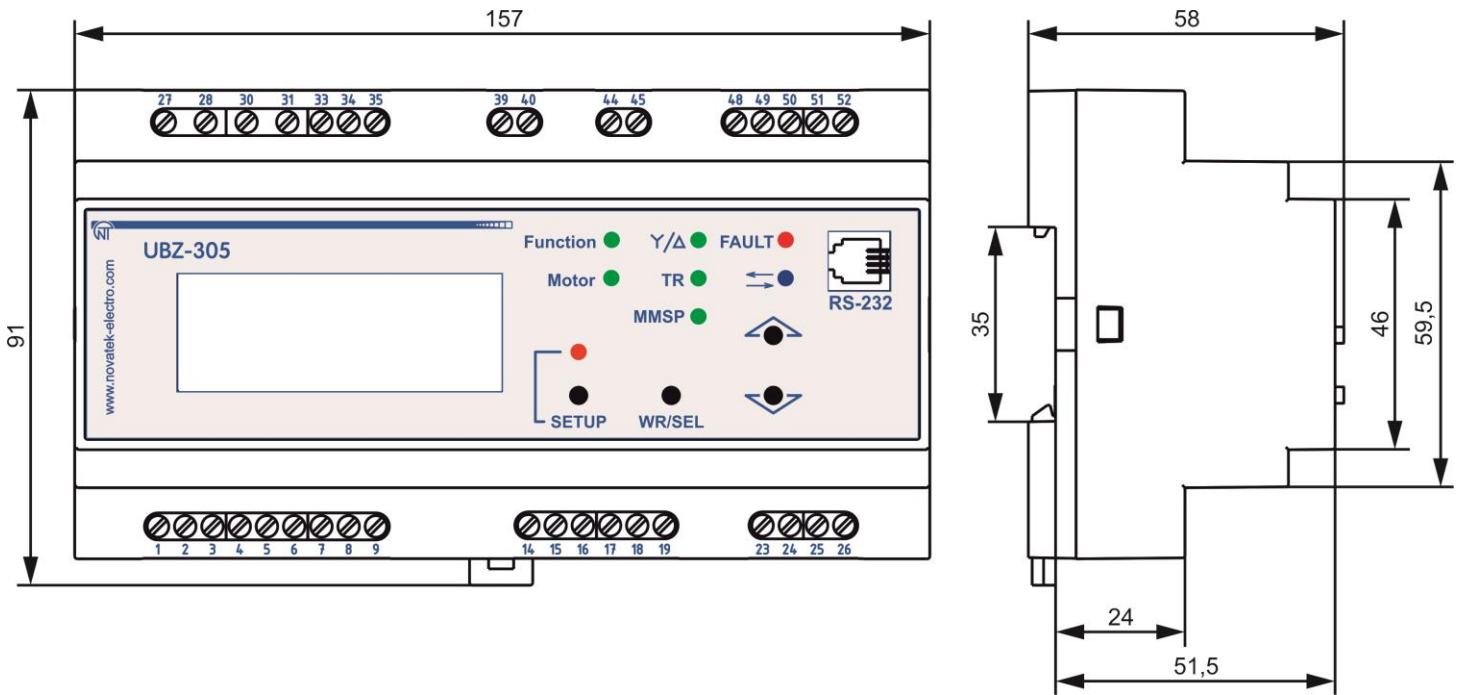
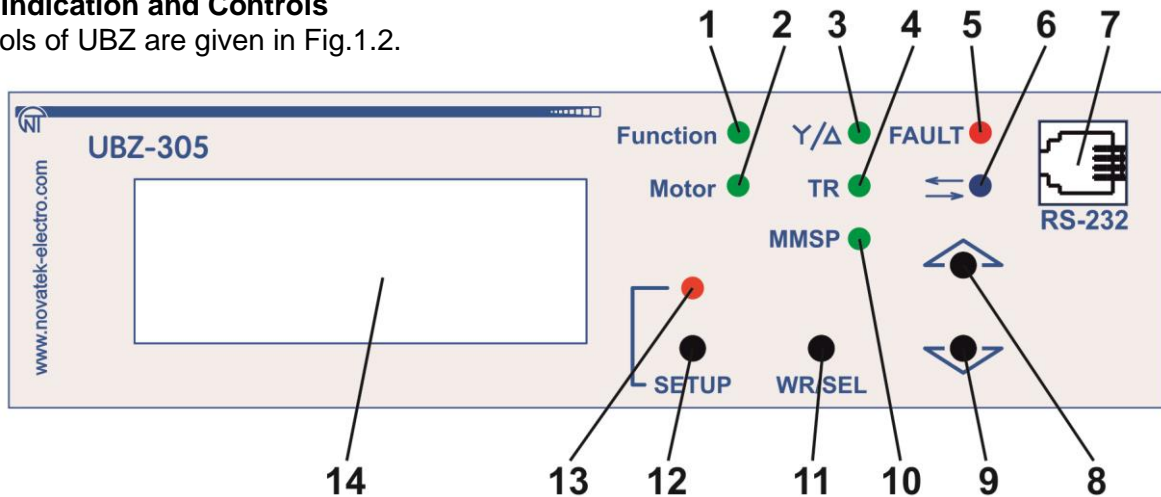

Fig.1.1 – Overall Dimensions of UBZ

1.4.2 Indication and Controls

Controls of UBZ are given in Fig.1.2.



- 1 – Green LED "Function" is on when functional relay is on;
- 2 – Green LED "Motor":
 - is on when load relay is enabled;
 - flashes if UBZ is within hysteresis band when controlling using analog inputs;
- 3 – Green LED " Δ/Δ " is on when UBZ functional relay operates in start-delta mode (it.2.5.3);
- 4 – Green LED "TR" is on when UBZ functional relay operates in time-delay relay mode;
- 5 – Red LED "FAULT":
 - when load relay is off: it is on when UBZ is in fault conditions (it flashes if after fault ARS is expected);
 - when load relay is on: it flashes when the motor is in conditions of over-current or thermal overload but relay off time has not come yet;
- 6 – Blue LED " \rightleftarrows " is on when data exchange with PC occurs;
- 7 – Connector for UBZ to a PC via RS-232;
- 8 – Button \blacktriangle (UP) is scrolling of displayed parameters in the parameter view mode and scrolling of the menu in the parameters setting mode;
- 9 – Button \blacktriangledown (DOWN) is scrolling of displayed parameters in the parameter view mode and scrolling of the menu in the parameters setting mode;
- 10 – Green LED "MMSP" is on when the relay is in MNS mode;
- 11 – Button "WR/SEL" is the parameters recording in the setting mode, switching over the group of displayed parameters in the view mode, reset;
- 12 – Button "SETUP" turns on the parameters setting mode;
- 13 – Red LED "SETUP" is on when UBZ is in the mode of parameters setting;
- 14 – LCD.

Fig.1.2 – Controls of UBZ

2 SPECIFICATIONS

2.1 Basic Technical Specifications

Basic technical specifications of UBZ are given in Tables 2.1 and 2.2; specifications of contacts of built-in relays are shown in Table 2.3.

Table 2.1 – General Data

Description	Unit of measurement	Value
Application of the unit	-	Switchgear and control-gear; induction motor protection control;
Design (installation) type		DIN rail 35 mm
Protection level	-	IP20
Climatic version		UHL 3.1
Operating temperature range*	°C	from minus 20 to +55
Contamination level		II
Overvoltage category		II
Rated voltage of insulation	V	450
Rated impulse withstand voltage	kV	2.5
Electric shock protection class		II
Wire cross section for connection to terminals	mm ²	0.5-2
Torque for terminal screws	N*m	0.4
*Note: It is allowed UBZ operation at temperatures from minus 35 to minus 20°C; in this case the readings on display can be not available.		

Table 2.2 – Technical Specifications

Description	Value
Operating supply voltage, three-phase	380 V, 50 Hz
Mains frequency, Hz	48-62
Rated current of CT, A	5
(Phase/line) voltage hysteresis, V	10/17
Heat hysteresis, in % of accumulated heat in case of shutdown	33
Determination accuracy of trip threshold for current, not more, in % of rated value	2
Determination accuracy of trip threshold for voltage, not more, V	3
Determination accuracy of out-of-phase voltage, not more, V	3
Voltage when maintaining serviceability: - phase voltage, when powered by one phase and zero wire is connected, not less, V - line voltage, when powered by three phases, not more, V	180 450
Analog inputs: - input to connect temperature transmitter (types: Pt100, Ni100, Ni120); - input to connect temperature transmitter of PTC-1000 type; - three analog inputs for standard CT with 5A output (T-0.66 type or similar); - input to connect differential current transformer (zero sequence transformer); - input to measure current of 0-20 mA; - input to measure voltage of 0-10 V.	
Main outputs: - load relay – two groups of changeover contacts to control the electric motor starter – 8 A, 250 V at $\cos \varphi=1$; - functional relay – one group of changeover contacts - 16A, 250V at $\cos \varphi=1$ (function of the relay is set by the user).	
Permit according to temperature of temperature transmitters, °C	1
Power consumption (under load), not more, VA	5.0
Weight, not more, kg	0.34
Overall dimensions (Fig.1.1), H*B*L, mm	91*157*58
Position in space	free
Housing material	self-extinguishing plastic

Table 2.3 – Characteristics of built-in relay output contacts

Relay	Max. current at U~250V	Number of actuations x1000	Max. switching power	Max. continuous boosting AC / DC voltage	Max. current at U _{cont} =30V
Functional relay Cos φ = 0.4 Cos φ = 1.0	5A 16A	100 100	4000 VA	440/300 V	5 A
Load relay Cos φ = 0.4 Cos φ = 1.0	2A 8A	100 100	2000 VA	460 V	3 A

2.2 Measured, calculated, special and service parameters

Special and service parameters are intended only for transmission using MODBUS interface (RS-485/RS-232). Special and service parameters are given in Table 2.4.

Measured and calculated parameters the values of which are displayed on LCD display, limits of their measurements and accuracy are given in Table 2.5.

Parameter values can be transferred to PC connected to one of the UBZ interfaces (MODBUS, RS-232). Parameter addresses are indicated in Table 2.5.

Table 2.4 – Special and Service Parameters

Measurement functions	Range	Remarks	Address
Heat balance of the motor Read-only parameter of RS-232, RS-485 interface	The number 1100000 corresponds to 100% of accumulated heat at which the motor is switched off when the thermal overload protection is enabled (it 2.4.7)	Read-only parameter	73,74
Index of the last fault in the fault logbook	It varies from 0 to 49, increasing by one after recording another fault in the fault logbook. When the number of faults will reach 50, the count of faults will begin again from scratch.	Read-only parameter	75

Table 2.5 – Measured and Calculated Parameters

Measurement functions	Range	Accuracy	Mnemonic	Address	Data transfer units
Currents					
Effective values of phase currents, A	0.5 – 6300	2%	Phase i1 Phase i2 Phase i3	30, 31, 32	The tenth of amperes. When working with measuring transformers with rated current over 100A, the currents (measured and calculated) in addition to the zero sequence current (ground fault) are transferred via RS-232/RS485 in amperes.
Effective value of positive-sequence current, A	0.5 – 6300	2%	Positive si	33	
Effective value of zero-sequence current, A	0.3 – 20	2%	Earth i0	34	
Negative-sequence current (imbalance), A	0.2 – 200	5%	Revers si	35	
Average current per each phase during the time specified in the parameter "Tm average I"			Average i1 Average i2 Average i3	36, 37, 38	
Maximum value of the average current for each phase obtained since the last download. Reset of all average values is performed by the button WR/SEL in case of displaying the maximum value of average current in any phase (by indication of the present average current of the respective phase).	<3 lct > 3 lct	2% 10%	Peak i1 Peak i2 Peak i3	39 40 41	
Motor starting current (average phase current) Overload current (average phase current) Starting time, s Starting time is the period of time from when all three-phase current will exceed 1.2 In and up to the moment when three currents will drop lower than 1.2 In. Maximum phase current achieved during this period is the maximum starting current.	<3 lct > 3 lct 0.1 – 600	2% 10%	Start i Overload i Start time	42 43 44	
Voltage					
Effective values of phase voltages (determined when connecting the neutral conductor to UBZ), V	100 – 300	3V	Phase U1 Phase U2	45 46	Volt

Table 2.5 (Continued)

Measurement functions	Range	Accuracy	Mnemonic	Address	Data transfer units
			Phase U3	47	Volt
Effective values of line voltages, V	100 – 475	5V	Line U1 Line U2 Line U3	48 49 50	Volt
Positive-sequence voltage, V	100 – 300	3V	Positive sU	51	
Negative-sequence voltage, V	3 – 300	3V	Revers sU	52	
Zero-sequence voltage (vector sum of three phase voltages divided by three), (it is defined when connecting to the neutral wire of UBZ), V	3 – 100	3V	Zero sU	53	
Miscellaneous					
Time counter of motor operation, day	0 – 999		Time motor	54	
Motor insulation resistance ¹ , MOhm	0 – 19.9	10%	Insulation	55	Hundreds of kOm
Mains frequency, Hz	45 – 65	1%	Frequency	56	Tenths of Hertz
Hold time before automatic restart ² , s	0 – 900	1 s	End of AR	57	Second
Time to overload trip (it indicates the time remaining until shutdown made by thermal overload protection) ³ , s	0 – 600	1 s	Before OvL	58	Second
Waiting time after overload trip (it indicates waiting time before permit to start-up blocked by thermal overload protection) ³ , s	0 – 900	1 s	After OvL	59	Second
Full power ⁴ , kVA	0 – 5000	5%	Apparent P	60, 61	Dozens of Watts
Active power ⁴ , kW	0 – 5000	5%	Active P	62, 63	
Reactive power ⁴ , kVA _r	0 – 5000	5%	Reactive P	64, 65	
Cosine of angle between voltage and phase current L1	0 – 1	5%	Cos A	66	Cosine of angle between voltage and current *1000
Cosine of angle between voltage and phase current L2	0 – 1	5%	Cos B	67	
Cosine of angle between voltage and phase current L3	0 – 1	5%	Cos C	68	
Temperature of transmitter 1 ⁵ , °C	minus 40 – 80	1°C	Temp dat 1	69	5000 – transmitter is off 1000+-10 – s.c. of transmitter 2000+-10 – transmitter breakout
Temperature of transmitter 2 ⁵ , °C	minus 40 – 220	1°C	Temp dat 2	70	
Current value at analogue input "4-20 mA", mA	0 – 25	2%	Input i	71	
Voltage value at analog input "0-10 V", V	0 – 10	2%	Input U	72	
Full electric power ⁶ , kVA/h	0 – 200000000	5%	ApE	90	
				91	
Active electric power ⁶ , kW/h	0 – 200000000	5%	AcE	92	
				93	
Reactive electric power ⁶ , kVA _r /h	0 – 200000000	5%	ReE	94	
				95	

Notes:

¹ If the insulation resistance of the motor is more than 20 MOm, then the value indicator displays code ">20M". When the motor is running (energized motor) the insulation resistance is not defined and the code indicator displays "---" (when measuring circuit of motor insulation connecting).

² If ARS is disabled, the indicator displays "not".

³ If the time before shutdown by thermal overload protection or waiting time before permit to start-up is not defined (more than 900 s), then the value indicator displays code "undef". If the protection function is disabled, the indicator displays "not".

⁴ If the power consumed by the load is more than 999 kW (kVA, kVA_r), the values of power are displayed with MW (MVA, MVA_r).

⁵ If the temperature value exceeds specified limits, then the indicator displays the alarm code in accordance with table 5.12. If the temperature sensor is disabled by software, then the indicator instead of temperature values displays "Off".

⁶ In excess of the energy meter of the value 200 000 000, the counter is reset and the energy metering will start from zero. Recording the current values of the energy in the non-volatile memory is performed every 15 min.

2.3 Programmable Parameters

Programmable parameters and their variation limits are given in Table 2.6.

Table 2.6 – Programmable Parameters

Settings and readings	Parameter on LCD	Min. value	Max. value	Factory setting	Message on LCD, actions	Address
Set the current time	Real Time			Setting of current time and date (it. 5.3.8)		See Table 5.9
Transformers						
Rated output current of used CT, A	CT out i	1	5	5		151
Rated current of CT, A	CT nom i	20	800	100		152
Basic parameters						
Rated current of motor, A	Rated Inom	0	630	0	0 – current is not set: UBZ will not enable the load relay (it.5.2.7).	150
Time during which the average current is measured, s	Tm average i	10	600	60	Time during which the average current is measured (parameters: "Average i1", "Average i2", "Average i3" of Table 2.4).	153
Over-current protection						
Type of over-current protection	Type I _{max}	0	5	0	0 – "Indep" - protection with independent time delay. Types of protection with dependent time delay: 1 – "SIT" ; 2 – "VIT (LTI)"; 3 – "EIT"; 4 – "UIT"; 5 – "RI".	154
Actuation setting for over-current protection, repetition factor	I _{max} coef	0.8	9	4	Repetition factor is set relative to rated motor current (it is used at "Type I _{max} " = "indep").	155
Current protection delay tripping, s	I _{max} delay	0.3	600	10.0		156
Permit for protection operation	I _{max} protec	0	2	2	0 – "Off" – protection is off; 1 – "OnnAR" – protection is on, ARS after tripping is disable; 2 – "On AR"- protection is on, ARS is enabled.	157
Sequence of tripping relative to overheating protection	I _{max} <>T	0	1	1	0 – "On" – tipping regardless of overheating protection; 1 – "Ind" – if there is no overheating, then over-current indicating displays but load relay is not disabled.	158
Ground fault protection (for zero-sequence current – I_e earth)						
Over-current tripping setting, A	I _e earth tresh	0.3	10	0.5	If the parameter is not included in MNS mode list, then default value is: 0.5 at I _n ≤50A; 1.0 at I _n >50A.	159
Tripping delay, s	I _e earth delay	0.3	2	1		160
Permit for protection operation	I _e earth protec	0	2	2	0 – "Off" - protection is off; 1 – "OnnAR" - protection is on, ARS after tripping is disable, 2 – "On AR"- protection is on, ARS is enabled.	161
Negative-sequence current protection						
Actuation setting, %	I ₂ rev tresh	5	20	10	It is set as percentage of rated current.	162
Tripping delay, s	I ₂ rev delay	0.3	10	5		163
Permit for protection operation	I ₂ rev Protect	0	2	2	0 – "Off" - protection is off; 1 – "OnnAR" – protection is on, ARS after tripping is disable; 2 – "On AR"- protection is on,	164

Table 2.6 (Continued)

Settings and readings	Parameter on LCD	Min. value	Max. value	Factory setting	Message on LCD, actions	Address
					ARS is enabled.	
Analysis of causes for negative sequence current tripping						
Ratio of exceeding negative-sequence current factor to negative-sequence voltage factor	A-s I2 coef	2	4	2		165
Permit for analysis	A-s I2 protec	0	1	1	0 – "Off"- analysis is off; 1 – "On"- analysis is on.	166
Thermal overload (heat model of the motor)						
Permit for protection operation	Termal OL protec	0	2	2	0 – "Off" - protection is off; 1 – "OnnAR" – protection is on, ARS after tripping is disable; 2 – "On AR" – protection is on, ARS is enabled.	167
Operating time of protection in case 2 time over-current, s	Termal delay	10	120	60		168
Factor of time increasing if motor is stopped	Termal C stop	1	4	1	Compensation of cooling time increasing while motor is stopped.	169
Minimum phase current						
Actuation setting, %	Imin tresh	11	90	20	Operation threshold for the minimum operating current protection, in % of installed rated one.	170
Tripping delay, s	Imin delay	1	100	5		171
Permit for protection operation	Imin protec	0	2	2	0 – "Off" – protection is off; 1 – "OnnAR" – protection is on, ARS after tripping is disable; 2 – "On AR" – protection is on, ARS is enabled.	172
Delayed start, rotor blocking						
Actuation setting, repetition factor	Start I Coef	1.3	7	5	Repetition factor is set relative to rated current	173
Delayed start tripping delay, s	Start I delay	1	600	10	Time of motor starting	174
Rotor blocking tripping delay, s	Block I delay	0.3	300	1		175
Permit for protection operation	St/Block prot	0	2	1	0 – "Off" – protection is off; 1 – "OnnAR" – protection is on, ARS after tripping is disable; 2 – "On AR" – protection is on, ARS is enabled.	176
Voltage protection						
Minimum line voltage, V	Umin tresh	270	415	320		177
Tripping delay for minimum line voltage, s	Umin delay	5	30	10		178
Permit for protection operation for minimum line voltage	Umin protec	0	2	2	0 – "Off" – protection is off; 1 – "OnnAR" – protection is on, ARS after tripping is disable; 2 – "On AR" – protection is on, ARS is enabled.	179
Maximum line voltage, V	Umax Tresh	330	450	415		180
Tripping delay for maximum line voltage, s	Umax delay	0.3	10	2		181

Table 2.6 (Continued)

Settings and readings	Parameter on LCD	Min. value	Max. value	Factory setting	Message on LCD, actions	Address
Permit for protection operation for maximum line voltage	Umax protec	0	2	2	0 – "Off" – protection is off; 1 – "OnnAR" – protection is on, ARS after tripping is disable; 2 – "On AR" – protection is on, ARS is enabled.	182
Line voltage imbalance, V	Uimbal tresh	15	120	35		183
Tripping delay for line voltage imbalance, s	Uimbal delay	1	30	5		184
Permit for protection operation for line voltage imbalance	Uimbal protec	0	2	2	0 – "Off" – protection is off; 1 – "OnnAR" – protection is on, ARS after tripping is disable; 2 – "On AR" – protection is on, ARS is enabled.	185
Permit for protection operation for phase sequence	Correct phase	0	2	1	0 – "Off" – protection is off; 1 – "OnnAR" – protection is on, ARS after tripping is disable; 2 – "On AR" – protection is on, ARS is enabled.	186
Motor phase loss with current control						
Tripping delay for phase loss, s	Phase LossT	0.3	10	0.5		187
Permit for protection operation	Phase Loss Prot	0	2	1	0 – "Off" – protection is off; 1 – "OnnAR" – protection is on, ARS after tripping is disable; 2 – "On AR" – protection is on, ARS is enabled.	188
Frequency protection						
Minimum value of voltage frequency, Hz	Frequency Min	35	60	49.7		189
Tripping delay for minimum voltage frequency, s	FreqMin delay	1	300	10		190
Permit for protection operation for minimum voltage frequency	FreqMin prot	0	2	0	0 – "Off" – protection is off, 1 – "OnnAR" – protection is on, ARS after tripping is disable, 2 – "On AR" – protection is on, ARS is enabled;	191
Maximum value of voltage frequency, Hz	Frequency Max	50	65	51		192
Tripping delay for maximum voltage frequency, s	FreqMax delay	1	300	10		193
Permit for protection operation for maximum voltage frequency	FreqMax prot	0	2	0	0 – "Off" – protection is off; 1 – "OnnAR" – protection is on, ARS after tripping is disable; 2 – "On AR" – protection is on, ARS is enabled.	194
Motor control and ARS						
ARS time after protection operation at minimum current, s	AR time Imin	1	900	600		195
ARS time, s	AR time	1	900	5		196
Disabled ARS for all faults (except voltage faults)	AR	0	1	1	0 – "Off" – ARS is disabled; 1 – "On" – ARS is enabled. AR parameter value covers all	197

Table 2.6 (Continued)

Settings and readings	Parameter on LCD	Min. value	Max. value	Factory setting	Message on LCD, actions	Address
					types of faults except voltage faults. To disable AR in case of voltage fault it is necessary to use the parameters "Umin protec", "Umax protec", "Uimbal protec".	
Permit for motor operation after UBZ energizing	Start>Power	0	2	1	0 – "StOff" – motor starting manually on UBZ front panel; 1 – "St>AR" – motor starting after ARS time; 2 – "St>2s" – motor start after 2s.	198
Motor control on UBZ front panel	MotorOp UBZ	0	3	0	0 – "Off"- it is disabled; 1 – "Start" – motor start is enabled; 2 – "Stop" – motor emergency shutdown is enabled; 3 – "St<>" – motor start-up and shutdown is enabled. See it.2.9	199
Motor remote start and shutdown via RS-232/RS485 interface	MotorOp RS-2/5	0	2	0	0 – "Off" – remote control is disabled; 1 – "OnSta" – remote control is enabled; motor start after UBZ energizing is enabled after ARS time; 2 – "OffSt" – remote control is enabled, motor start after UBZ energizing is disabled until the command for remote energizing.	200
Temperature control						
Permit for temperature control and type of temperature transmitter 1	Temp S1 Type	0	2	0	0 – "Off " – it is disabled; 1 – "R>1.7" – it is of motor built-in type (protection is enabled if the transmitter resistance is above 1.7 Ohm); 2 – "PTC" – PTC (1kOhm at 25°C).	201
Motor trip temperature	Temp S1 Off M	0	100	80		202
Temperature correction of the first transmitter	Temp S1 Corr	-9	9	0		203
Permit for temperature control and type of temperature transmitter 2	Temp S2 Type	0	3	0	0 – "Off " – it is disabled; 1 – "Pt100" – of Pt100 type; 2 – "Ni100" – of Ni100 type; 3 – "Ni120" – of Ni120 type.	204
Motor trip temperature	Temp S2 Off M	0	220	180		205
Warning temperature	Temp S2 Alarm	0	220	170		206
Temperature correction of the second transmitter	Temp S2 Corr	-9	9	0		207
ARS after tripping	Temp AR	0	1	1	0 – "Off" – ARS is disabled; 1 – "On" – ARS is enabled.	208
Temperature transmitters fault reaction	Temp Sens Fault	0	1	0	0 – "AonM" – warning and continuation of operation; 1 – "AoffM" – warning and motor stop.	209

Table 2.6 (Continued)

Settings and readings	Parameter on LCD	Min. value	Max. value	Factory setting	Message on LCD, actions	Address
Motor insulation resistance						
Protection for the motor minimum insulation resistance	Insulation Mr	0	4	1	0 – "Off" – it is disabled; 1 – "5 AR" – motor is not enabled when insulation resistance is less than 500 kOhm, ARS is enabled; 2 – "10 AR" – motor is not enabled when insulation resistance is less than 1000 kOhm, ARS is enabled; 3 – "5 nAR" – motor is not enabled when insulation resistance is less than 500 kOhm, ARS is disabled; 4 – "10nAR" – motor is not enabled when insulation resistance is less than 1000 kOhm, ARS is disabled.	210
Miscellaneous						
Activating the mode of minimum number of settings	Minimal set	0	1	1	0 – "Off" – the mode is disabled; 1 – "On" – the mode is enabled. The mode change is possible only in advanced user mode.	211
Indications on UBZ display before starting the motor	Indicat <Start	0	1	0	0 – "LineU" – line voltage: "Line U1", "Line U2", "Line U3"; 1 – "InsFr" – motor running time ("Time motor"), motor insulation resistance ("Insulation"), mains frequency ("Frequency").	212
Parameter display mode	Indicat mode	0	1	0	0 – "Conti" – the parameter value is displayed continuously, 1 – ">15s" – the parameter value is displayed for 15 s	213
Functional relay operating mode	Relay F mode	0	2	0	0 – "Alarm" – relay is used as alarm relay; 1 – "Timer" – the relay is used as time relay (it is enabled after enabling the load relay after the time set parameter of "Relay F time"); 2 – "St->D " – the relay is used for motor star-delta switching (after time of "Relay F time" (address -215) the load relay is disabled, and after time of "Relay F time" (address-215) + "Delay RP RF" (address-216) the functional relay is enabled).	214
Timer value, s	Relay F time	0	300	30	See it.2, it.3 of the parameter "Relay F mode" (address-214).	215
Star-delta mode. Switching time, s	Delay RP RF	0.1	2	0.4	The time between the load relay disabling and functional relay enabling in star-delta mode.	216
Total time of the unit operation, day	Time UBZ	0	999	0	*When data transmitting by MODBUS/RS-232 interface the operating time is transmitted in hours.	217
Motor operating time, day	Time motor	0	999	0	* When data transmitting by MODBUS/RS-232 interface the operating time is transmitted in hours.	218

Table 2.6 (Continued)

Settings and readings	Parameter on LCD	Min. value	Max. value	Factory setting	Message on LCD, actions	Address
Access code of user	Users code	0	9	0	0 – keyboard is unblocked; 1-9 – user password/	219
Access code of advanced user	Password	000	999	123	000 – access to advanced user level is permitted; 000-999 – advanced user password.	220
Factory settings reactivating	Default Factor	0	1	0	0 – "Off", 1 – "On" After "On" message and the settings setup mode quit, the factory settings will be reactivated (except the access code of advanced user)	221
The serial interface parameters (RS-485/ RS-232)						
UBZ communication address	Address UBZ	1	247	1		222
Transfer rate ²	Data speed	0	1	0	0 – "9.6 k" – 9600 baud; 1 – "19.2k" – 19200 baud.	223
Converter reaction to loss of connection	Loss connect	0	3	0	0 – "non" – continuation without warning; 1 – "Alarm" – warning and continuation of operation; 2 – "StpAR" – warning and motor stop with ARS permit after restoring the connection; 3 – "StpnA" – warning and motor stop with ARS disabled after restoring the connection.	224
Detection of response overtime, s	Overexceeding	0	120	0	0 – It is disabled.	225
Permit of UBZ communication via serial link	Communication	0	2	0	0 – "Off" – communication is disabled; 1 – "RS232" – communication via RS-232; 2 – "RS485" – communication via RS-485.	226
Type of communication protocol ²	ASCII-RTU	0	1	1	0 – "ASCII"; 1 – "RTU" – MODBUS modes.	227
Parity check ²	Even parity	0	1	0	0 – "Off" – parity check is disabled; 1 – "On" – parity check is enabled.	228
Number of stop bits ²	Stop bit	1	2	2		229
Unit version	Version			8	The parameter value depends on software version.	230
Indicator illumination ¹	Indicator L	0	2	1	0 – "Off" – illumination is off; 1 – "On15s" – illumination is on for 15 s after pressing any buttons; 2 – "On" – illumination is on continuously.	231
Clock correction, s	Correct Time	-10	10	0	Correction of the real time clock. Compensation of time for the day.	232
Control via analog input 0-20 mA						
Upper threshold, mA	Input I UP	0	20	10		233
Lower threshold, mA	Input I DOWN	0	20	1		234
Control algorithm	Input I ALG	0	2	0	0 – "Off" – control is off; 1 – "OffUP" – the motor is off when the current is higher than	235

Table 2.6 (Continued)

Settings and readings	Parameter on LCD	Min. value	Max. value	Factory setting	Message on LCD, actions	Address
					the upper threshold and it is on when the current is lower than the lower threshold; 2 – "OnUP" – the motor is on when the current is higher than the upper threshold and it is off when the current is less than the lower threshold.	
Entry in faults logbook	Input I log	0	1	0	0 – "OffWr" – motor cutoff is considered the fault but not recorded in the fault logbook; 1 – "OnWr" – motor cutoff is considered the fault and is recorded in the fault logbook.	236
Control via analog input 0-10 V						
Upper threshold, V	Input U UP	0	10	5		237
Lower threshold, V	Input U DOWN	0	10	1		238
Control algorithm	Input U ALG	0	2	0	0 – "Off" – control is off; 1 – "OffUP" – the motor is off when the voltage is higher than the upper threshold and it is on when the voltage is lower than the lower threshold; 2 – "OnUP" – the motor is on when the voltage is higher than the upper threshold and it is off when the voltage is less than the lower threshold.	239
Entry in faults logbook	Input U log	0	1	0	0 – "OffWr" – motor cutoff is considered the fault but not recorded in the fault logbook; 1 – "OnWr" – motor cutoff is considered the fault and is recorded in the fault logbook.	240
Serviceability check of external magnetic starter (MS)	Cont Cont	0	1	1	0 – "Off" – check is disabled; 1 – "On" – check is enabled.	241
Energy meters reset	Energy RESET	0	1	0	0 – "Off"; 1 – "On" – reset.	242
Notes:						
1 – Indicator light turns off if the line supply voltage is lower than 250 V.						
2 – Parameter change will happen after turning off and repeated energizing or fulfillment of "UBZ RESTART" command						

2.4 Protection Functions

2.4.1 Protection Types

UBZ performs the following protection types for electric motors:

- over-current protection in phases;
- ground fault protection (for zero-sequence current);
- for negative-sequence current;
- for exceeding negative-sequence current factor to negative-sequence voltage factor;
- for thermal overload;
- undercurrent protection in phases;
- delayed starting (rotor blocking);
- overheating of windings;
- for minimum line voltage;
- for maximum line voltage;
- for line voltage imbalance (negative sequence voltage protection);

- for improper phase sequence;
- for decreasing of mains frequency lower than setting;
- for increasing of mains frequency higher than setting;
- for minimum insulation resistance of the motor winding;
- for the motor phase loss (protection is operated when the motor current is disabled in one (two) phase).

2.4.2 Maximum phase current protection is of three-phase type.

Maximum current protection on phase is three phase. It is enabled when one, two or three current values reach the actuation set-point.

The protection has time delay. The time delay can be definite (constant) or dependent (inverse-definite - **SIT**; very inverse-definite - **VIT** or **LTI**; extremely inverse-definite - **EIT**; ultra inverse-definite - **UIT**, time delay of **RI** type) - curves are shown in Appendix A.

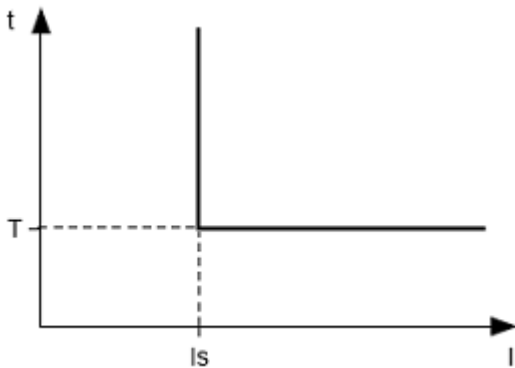

In case of the protection with definite time delay the motor is off when the current of one phase is more than specified for the time T (“I_{max} delay” parameter).

I_s = “I_{max} coef” (tripping ratio); * “Rated I_{nom}” (motor rated current), and T is the delay time of the protection operation (“I_{max} delay”).

Example: When “I_{max} coef” = 4.0, “Rated I_{nom}” = 10, “I_{max} delay” = 10.0, the motor will switch off in 10 seconds after one of the phase currents exceeds 40 amp.

Fig.2.2 – Principle of protection with definite time delay

Protection with dependent time delay corresponds to the standards IEC 60255-3 and BS 142.

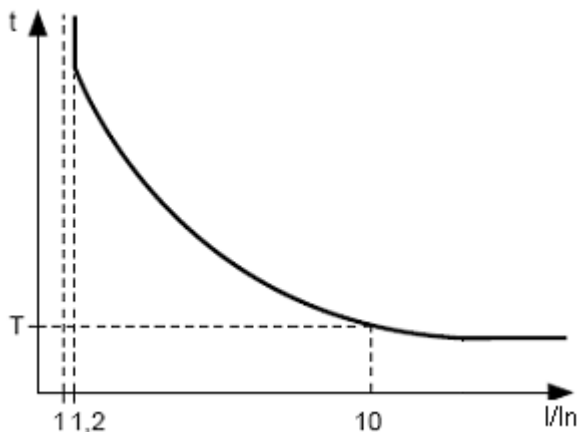

In corresponds to the set-point “Rated I_{nom}” (motor rated current);

T (“I_{max} delay” parameter is time constant of the protection operation) corresponds to time delay of tripping for 10*I_n.

For very large currents the protection has a feature with definite time delay:

Fig.2.3 – Principle of protection with dependent time delay

Appendix A provides curves for the time constant of the protection to equal 1 second (“I_{max} delay” parameter). When setting the different value of the time constant, the response time of the protection is changed proportional to the time constant (for example, when “I_{max} delay” = 10 seconds, operating time of protection at the same ratio of currents will increase 10 times).

2.4.3 Ground fault protection:

- It is enabled when ground-fault current reaches the tripping threshold (“I_{earth} tresh” parameter);
- the motor switches off if the ground-fault current is more than specified for the time T (“I_{earth} delay” parameter).

2.4.4 Negative-sequence current protection (imbalance)

Negative-sequence current protection (imbalance) is enabled when a component of the negative sequence is more than the set-point (“I₂ rev tresh” parameter) and stops the motor when time of this excess is more than specified value (“I₂ rev delay” parameter”).

If the analysis of tripping cause is enabled (“A-s I₂ prot”=“On”), then in case of protection tripping due to exceeding of negative sequence current not because of line voltages imbalance (in this case the motor problems are assumed), ARS after tripping will not occur (regardless of the value of “I₂ rev protec” parameter).

The coefficient of negative voltage (current) sequence is characteristic of unbalance of three-phase voltage (current). Approximately the coefficient of negative voltage sequence is determined by the formula:

$$\sim 18 \sim$$

$$K_{2Ui} = \frac{U_{2(1)i}}{U_{1(1)i}} \cdot 100,$$

Where:

$U_{2(1)i}$ — RMS value of negative voltage sequence of fundamental frequency of three-phase voltage system in i - observation, V;

$U_{1(1)i}$ — RMS value of positive voltage sequence of fundamental frequency in i - observation, V.

$U_{2(1)i}$ is calculated by the approximate formula:

$$U_{2(1)i} = 0.62(U_{H\delta(1)i} - U_{HM(1)i}),$$

where - $U_{H\delta(1)i}$, $U_{HM(1)i}$ - maximum and minimum RMS values of the three phase-to-phase voltage of the fundamental frequency in i - observation, V.

The coefficient of negative current sequence K_{2li} is calculated similarly.

If currents imbalance is caused not by voltage imbalance, then motor fault is determined. To determine the cause of currents imbalance it is necessary to calculate the ratio of the coefficient of negative current sequence to the coefficient of negative voltage sequence (K_{2li} / K_{2Ui}). And if the ratio is more than the value of "A-s I2 coef" parameter, then UBZ considers that the motor has malfunction.

2.4.5 Minimum phase current protection:

- it is enabled when the currents of all three phases drops lower than the set-point ("Imin tresh" parameter) and stops the motor when this drop time is more than the specified one ("Imin delay" parameter);
- it is not active when the load current is less than 10% I_n (when decrease of the current is due to motor shutdown, not due to decrease of its load);
- It has its own definite time delay of ARS ("AR time Imin" parameter).

2.4.6 Delayed start and rotor blocking

The principle of delayed start protection and rotor inter-blocking is given in Fig.2.4.

Delayed start

During start-up the protection is enabled when all phase currents are more than the set-point I_s ("Start I Coef" parameter) during the period of time more than the ST time delay ("Start delay I" parameter).

Rotor blocking

After motor start performing (reducing the starting current lower than 1.2 of rated one) UBZ switches to control of possible blocking of the rotor. The protection system operates when all the phase currents are more than set-points during a period of time greater than LT time delay ("Block I delay" parameter).

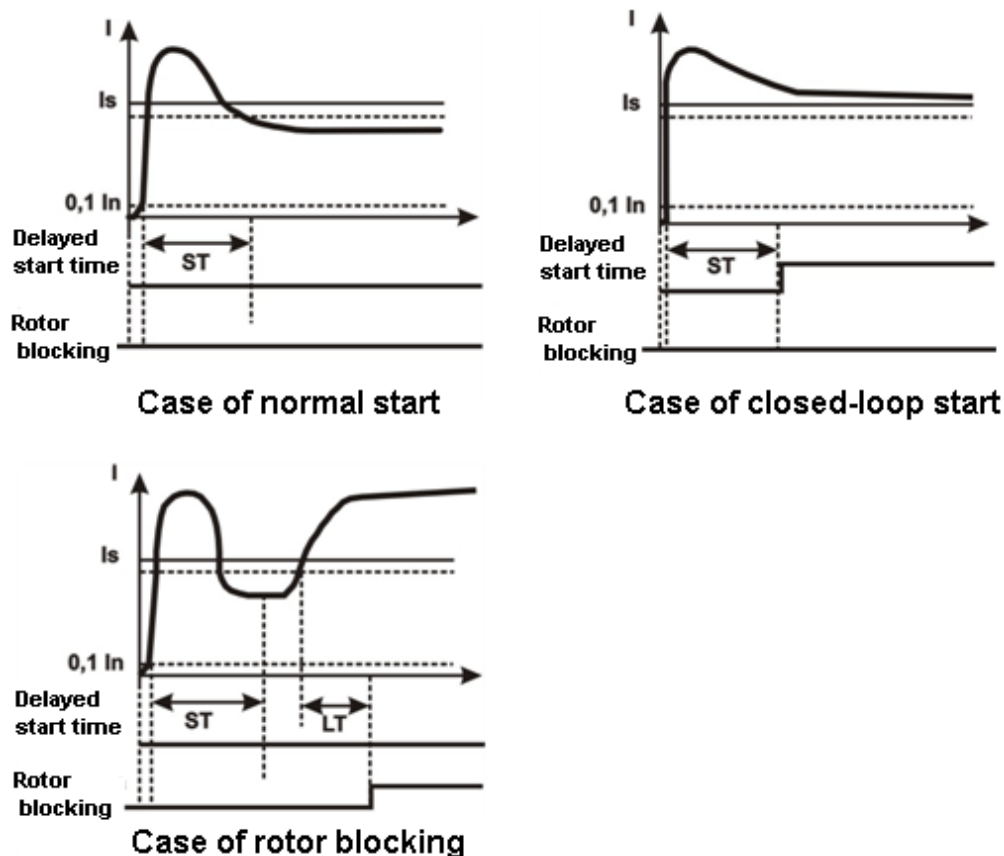

Fig. 2.4 – Delayed start and rotor blocking

2.4.7 Thermal overload protection

Thermal overload protection is made on the basis of the equation solution of motor thermal balance under the following assumptions:

- before the first start the motor was cold;
- during the motor operation, heat generates that is proportional to the square of the current;
- after motor turning off it is cooled down exponentially.

For protection, you should enter the response time in case of double overload T2 (the parameter of “Thermal delay”).

Current-time characteristic with different values of T2 is given in Fig.2.5.

For the standard recommended T2 value (60 s at 2 time overload) Table 2.7 shows the following current-time characteristic.

Table 2.7

I/Inom	1.1	1.2	1.4	1.7	2	2.7	3
Tsec	365	247	148	88.6	60	36.4	24.6
I/Inom	4	5	6	7	8	10	15
Tsec	13.5	8.5	5.9	4.3	3.3	2.1	0.9

For rotating machines, cooling is more efficient during operation than during the stop of the motor, so enter the parameter “Thermal C stop” - the constant increase rate of cooling when the motor is stopped.

After the load relay disabling owing to thermal overload with ARS permitted, the relay will be enabled again after the time more than the maximum of the two values:

- time of thermal hysteresis (motor should cool down to 33% of the accumulated heat);
- time of ARS.

Choosing different ARS time periods considering thermal hysteresis, one can reduce the number of starts per time unit because in the intermittent mode of operation UBZ remembers the amount of heat released during the motor start.

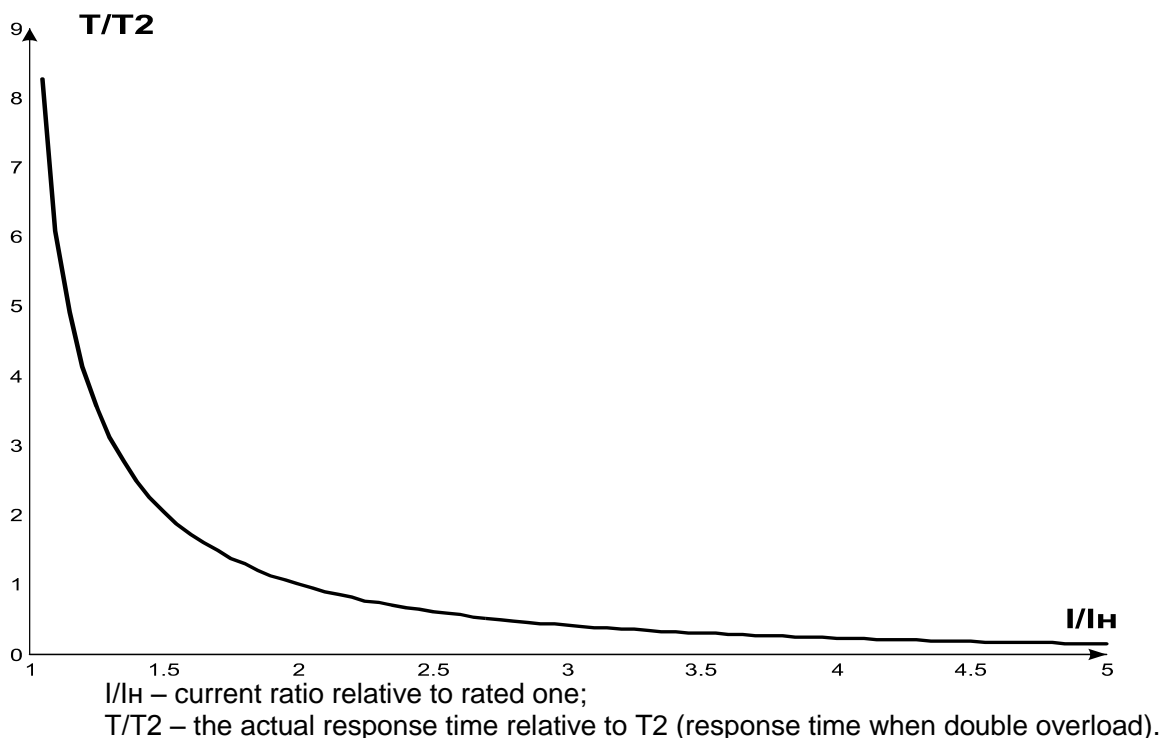

Fig.2.5 – Current-time characteristic

2.4.8 Windings overheating protection

The first input protection:

- when working with motor built-in temperature transmitters (parameter “Temp S1 Type”=“R>1.7”) protection is enabled when the transmitter resistance will be more than 1700 Ohms. Set-point “Temp S1 Off M” is not used: short-circuit and breakout of the transmitter is not controlled;
- when working with transmitters of PTC type (1kOhm at 25°C) (“Temp S1 Type” = PTC parameter), protection is enabled and stops the motor when the monitored temperature is more than the set-point (“Temp S1 Off M” parameter).

When working with PTC type transmitters, protection defines the cases of breakout and short circuit of the transmitter:

- the breakout at the temperature higher than 100°C;
- short circuit at the temperature less than minus 45°C.

The second input protection:

- it is enabled when the controlled temperature is higher than set-point;
- it has two independent set-points: the alarm set-point (“Temp S2 Alarm” parameter) and the set-point for the motor is off (“Temp S2 Off M” parameter).

Protection determines the cases of breakout and short circuit of the temperature transmitters:

- breakout at temperature of more than 220°C;
- short circuit at temperature of less than minus 45°C.

On the second input the protection is operated with temperature transmitters of Pt100 type (platinum type for 100 Ohm at 0°C) or Ni100 (Ni120) (Nickel type for 100 Ohm (120 Ohm) at 0°C) in accordance with the standards of

IEC 60751 and DIN 43760.

2.4.9 Voltage protection

In UBZ voltage protection before enabling the load it is necessary to check the corresponding set-points and depending on their value, the load relay enabling will be permitted or disabled; when the motor is on, the voltage control is fulfilled, but the decision relative to disabling is made according to currents.

Note – UBZ considers the motor is switched off if the load relay is off (operating in star-delta mode the load relay and functional relay are disabled), or if the load relay is on, the motor currents are less than 10 percent of the motor rated current.

The voltage protections are the following:

- at minimum line voltage (it is enabled if at least one of the line voltages is less than the set-point (“Umin tresh” parameter) within the time specified by “Umin delay” parameter);
- at maximum line voltage (it is enabled if at least one of the line voltages is more than the set-point (“Umax tresh” parameter) within the time specified by “Umax delay” parameter);
- during line voltages imbalance (it is enabled if the difference between **effective** values of the line voltages is more than the set-point (“Uimbal tresh” parameter) within the time specified by “Uimbal delay” parameter).

2.4.10 Phase sequence protection (“Correct phase” parameter) is enabled in case of improper phase sequence; it disables the motor and blocks its further operation.

2.4.11 Network power frequency drop protection is enabled, if the network power frequency is less than the set-point (“Frequency Min” parameter) within the time specified by “FreqMin delay” parameter.

2.4.12 Network power frequency rise protection is enabled, if the network power frequency is higher than the set-point (“Frequency Max” parameter) within the time specified by “FreqMax delay” parameter.

2.4.13 Protection for minimum resistance of motor winding insulation

After UBZ energizing before the output relay will be on, it is necessary to check the insulation level of stator winding relative to the housing. The level of stator winding insulation relative to housing is also checked, when the load relay is on, but the motor currents are less than 10% of rated current (in this case UBZ considers that the motor is off).

When “Insulation Mr” = “5 AR” (“5 nAR”) the load is disabled if the insulation resistance is lower than 500 kOhm ±20 kOhm, and when “Insulation Mr” = “10 AR” (“10 nAR”) if it is less than 1000 kOhm ±50 kOhm. During automatic restarting “AR”, the load will on after restoring the insulation resistance and after ARS time finishing. If “nAR”, ARS will not on.

2.4.14 Protection for the motor phase (-s) break (loss) is enabled, if one of the motor phase current is more than 10% of the rated one (“Rated Inom” parameter), and any of the remaining phases of the motor is less than 7% of the motor rated current.

2.4.15 Serviceability check of external magnetic starter

UBZ detects the motor currents when the load relay is off (if the load relay and functional relay is off in star-delta mode). In this case, UBZ indicates the fault of external MS enabling the motor, until then UBZ is turned off or control of the motor currents is disabled when load relay is off (Cont Cont = 0 (“Off”) parameter).

2.5 Selection of Current Transformers (CT)

Rated output current of CT should be 5A.

Rated input current of CT (Ict) is selected based on the rated current of the motor (In), the motor starting current, start duration, the time required for ARS (taking into account the characteristics of UBZ inputs designed to connect CT (Table 2.8)).

Table 2.8 – Characteristics of UBZ inputs designed to connect CT

Current of UBZ inputs designed for measurement of CT output currents, A	Ratio of overload relative to rated current (5A)	Maximum duration of current action, s	Minimum delay before restarting, s
0 – 12	2,4	continuously	-
12 – 15	3	60	10
16 – 20	4	30	15
21 – 25	5	15	30

ATTENTION: MAXIMUM CURRENT OF UBZ INPUTS DESIGNED FOR MEASUREMENT OF CT OUTPUT CURRENTS IS 25 A.

Rated input current of CT should be within the range: $I_n < I_{ct} < 3 \cdot I_n$.
It is recommended to use CT with $I_{ct} = 2 \cdot I_n$.

3 UBZ DESIGN

UBZ is microprocessor-based digital device that provides a high degree of reliability and accuracy. Operational power is not required. The controlled voltage is simultaneously the power supply voltage.

4 SAFETY PRECAUTIONS

During operation and maintenance it is necessary to comply with the requirements of regulatory documents:

- Regulations for Operation of Consumer Electrical Installations;
- Safety Rules for Operation of Customer Electrical Installations;
- Occupational Health and Safety during Electrical Installations Operation;



TO ENSURE SAFE OPERATION OF THE PRODUCT IT IS STRICTLY FORBIDDEN:

- TO CARRY OUT INSTALLATION WORKS AND MAINTENANCE WITHOUT SWITCHING THE UNIT OF POWER SUPPLY;
- TO OPEN AND REPAIR THE UNIT INDEPENDENTLY;
- TO OPERATE THE UNIT WITH MECHANICAL DAMAGES OF THE HOUSING;
- TO PENETRATE MOISTURE ON CONTACTS OF TERMINAL BLOCKS AND THE INTERNAL ELEMENTS OF THE UNIT.

5 INTENDED USE

5.1 SAFETY PRECAUTIONS



TO ENSURE SAFE OPERATION OF THE PRODUCT IT IS STRICTLY FORBIDDEN:

- TO CARRY OUT INSTALLATION WORKS WITHOUT SWITCHING THE UNIT OF POWER SUPPLY;
- TO OPERATE THE UNIT WITH MECHANICAL DAMAGES OF THE HOUSING;
- TO PENETRATE MOISTURE ON CONTACTS OF TERMINAL BLOCKS AND THE INTERNAL ELEMENTS OF THE UNIT.

5.2 UBZ Preparation for Use

ATTENTION: To improve performance properties of UBZ, it is recommended to install fuses (fusible elements or their analogues) in the following circuits (listed in the order required; a hyphen is the recommended fuse value):

- 1) UBZ power supply circuits (27, 28, 30 – L1, L2, L3) – 1 A;
- 2) circuits for measurement of temperature, current, voltage (39, 40, 44, 45, 48-52) – 0.5 A;
- 3) RS-485 (33 - 35) – 0.5 A;
- 4) relay output contacts (the fuse rating is selected according to the connected circuits, but it should not exceed for contacts 1-3 – 15 A, for contacts 4-9 – 5 A).

5.2.1 Connect the current transformers in accordance with Fig.5.2;

5.2.2 Pass through a differential current transformer (zero sequence transformer) all three phase wires and connect it to UBZ;

5.2.3 To monitor and measure the motor insulation, connect the control terminal of the insulation **25** to one of output contacts of MS. If the motor housing is not grounded, or network with isolated neutral is used, or

neutral wire is not connected to UBZ terminal, it is necessary to connect electrically the motor housing to the terminal **26** of UBZ.

5.2.4 Connect the motor to UBZ in accordance with Fig.5.2. When using the motor with the switching over the windings during star-delta starting-up, perform the connection in accordance with Appendix B.

5.2.5 To work with UBZ from personal computer as the control or supervising using the program of "UBZ Control Panel" it is necessary:

- to install on the PC the program of "UBZ Control Panel", starting the program "Setup_cplubz304(X.X).exe" (X.X – number of software version);
- to connect "RS232" connector on the top panel of UBZ to RS-232 connector of PC using the cable KC-01;
- to set the parameter of "Communication" = "RS232".

Notes:

1) Program "Setup_cplubz304(X.X).exe" can be found at website of NOVATEK-ELECTRO Company: (http://www.novatek-electro.com/production_ubz.htm).

2) The unit is completed with the cable KC-01 when ordering. It is possible to manufacture the cable independently by the user in accordance with Fig.5.12.

3) Programs developed by the user are allowed to be used for operation with UBZ.

5.2.6 In case of MODBUS usage, connect the communication lines to terminals **10 (GND)**, **11 (line B RS-485)**, **12 (line A RS-485)** of UBZ. Set the parameter of "Communication" = "RS485".

5.2.7 Energize UBZ

ATTENTION – UBZ is supplied with set rated current of motor equal to zero. In this case, UBZ load relay will not be enabled until the rated current of the motor. Motor rated current should be at least 3 A.

The enabling sequence for the load relay after energizing is determined by the values of the parameters "AR time" and "Start>Power" (it.5.5.1.1).

5.2.8 In the course of first starting in accordance with factory settings UBZ is in the mode of MNS in which it is possible to set the following parameters:

- CT rated current (parameter of "CT nom i");
- motor rated current (parameter of "Rated Inom").

For normal operation of UBZ it is enough to set these parameters according to used CT and the motor.

5.2.9 Disable power of UBZ;

5.2.10 Connect the magnetic starter (hereinafter referred as MS) of the motor in accordance with Fig.5.2.

Note – When load relay is enabled, the contacts **4-5** and **7-8** are closed; when relay is off, the contacts **5-6** and **8-9** are closed

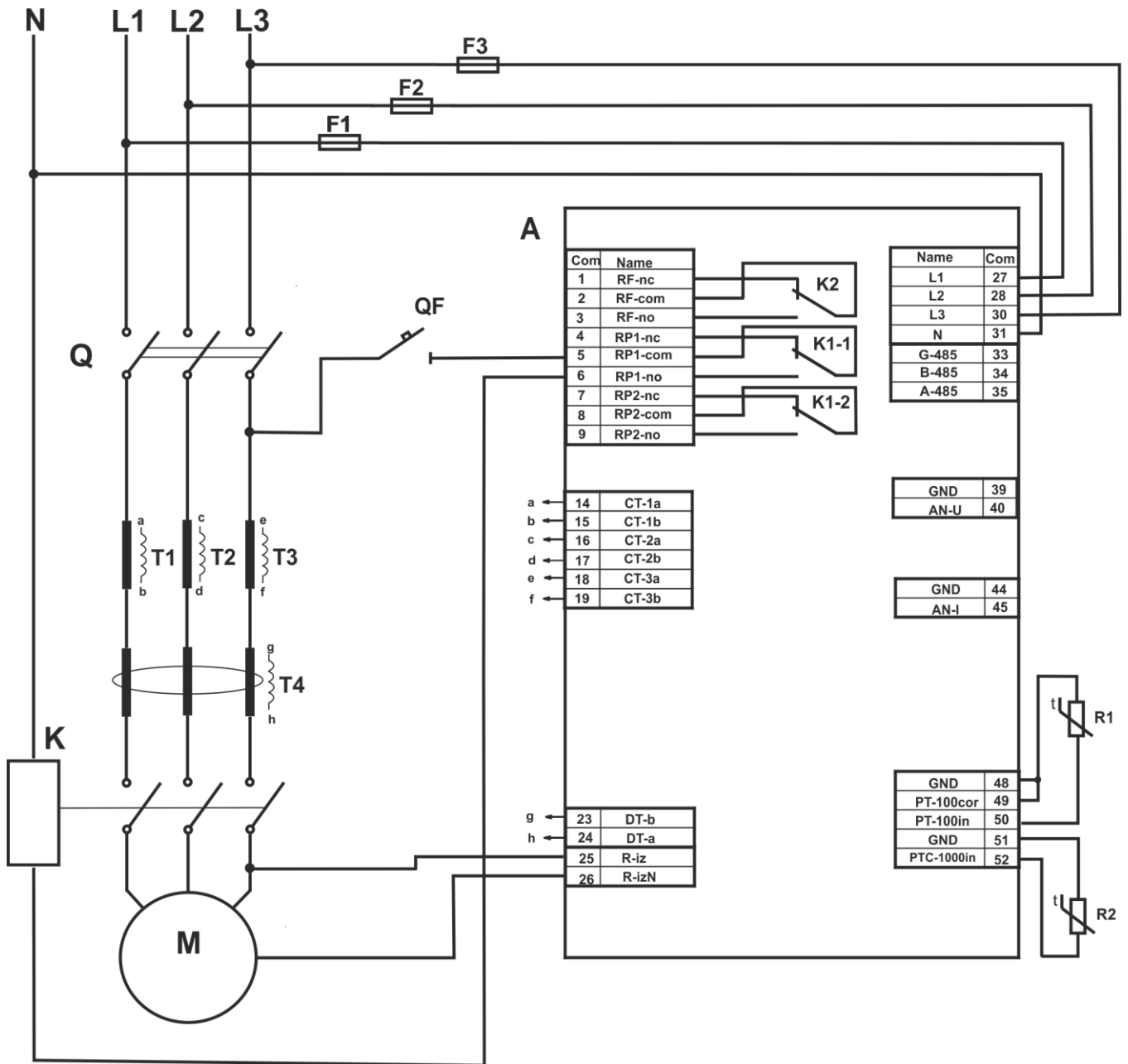

- A – UBZ;
- F1- F3 – Fusible element for 1 A (or its equivalent);
- K – Magnetic starter (MS);
- R1 – Temperature transmitter (for example: PT100);
- R2 – Temperature transmitter (for example: PTC1000, EKS111 made by DANFOSS);
- Q – Circuit breaker;
- QF – Circuit breaker at a maximum current of 6.3 A;
- T1-T3 – Current transformer (output 5 A);
- T4 – Differential transformer.

Fig.5.2 – UBZ Connection Diagram

5.3 UBZ Control

5.3.1 Modes of UBZ control and status

UBZ has five control modes:

- **Keyboard blocking;**
- **MNS;**
- **User level;**
- **Advanced user level;**
- **Remote control.**

All the modes of control have possibility to switch UBZ in the state:

- **Viewing the measured and calculated parameters** (Table 2.5);
- **Viewing the faults logbook** (it. 5.8).

5.3.2 Measured and calculated parameters view state

Measured and calculated parameters view state is the principal state. From all other modes UBZ returns to this mode automatically (if after 30 s, no button is pressed).

In this mode the first three lines of the indicator displays a group of three functionally close settings (when adding the values of temperature transmitters or analog inputs – a group of two parameters) (Fig.5.3).

Note – If any temperature transmitter is disabled by software, then instead of the temperature (resistance) value the indicator displays “Off”.

The information displayed in the fourth line of the indicator depends on the state of UBZ.

If the load relay is enabled, then the fourth line of the display shows the current time (Fig.5.3).

Phase i1, A	345
Phase i2, A	350
Phase i3, A	342
	15:30:17

The display shows:

- In line 1 – current in phase A – 345 A;
- In line 2 – current in phase B – 350 A;
- In line 3 – current in phase C – 342 A;
- In line 4 – current time.

Fig.5.3 – UBZ Indicator in view mode of measured and calculated parameters (load relay is on)

If the load relay is off, then the fourth line of the indicator can display the following:

1) "AR=NOT Ir=0 15:30:17" in case if the motor start is impossible as the motor rated current is not set (parameter of "Rated Inom" =0);

2) "AR=NOT 15:30:17" in case if the fault occurred after which ARS is disabled;

3) "AR=350 15:30:17" in case if the fault occurred and ARS is possible (ARS time account is on – 350 s left to ARS).

In the second and third variant, information of the fourth line of the indicator is consistently changing – in addition to reports about the possibility of starting the motor; it displays the total number of faults and type of fault on the display (Fig.5.4). For example, if the information on the indicator corresponds to Fig.5.4, then in 2s the fourth line displays the fourth type of fault.

Line U1, V	345
Line U2, V	312
Line U3, V	210
I _{max}	Er 3: 8

The display shows:

- In line 1 – line voltage U1 – 345 V;
- In line 2 – line voltage U1 – 312 V;
- In line 3 – line voltage U1 – 210 V;
- In line 4 – "I_{max}" – type of fault (over-current protection); "Er 3:8" – the indicator displays the third fault; total number of existing types of faults is 8.

Fig.5.4 – UBZ Indicator in view mode of measured and calculated parameters (in fault conditions)

5.3.3 Mode of Keyboard blocking

When the keyboard is blocked you cannot view and reinstall the programmable parameters.

When the keyboard is blocked, pressing the "**SETUP**" button leads to the appearance on the indicator the message “blocked buttons” (Fig.5.5).



Fig.5.5 – Indicator when the keyboard is blocked

To unblock the keyboard, it is necessary to press again the "**SETUP**" button. The led turns on "**SETUP**", and the indicator displays the inscription “USERS PASSWORD” and “<0>”. With the help of **UP** and **DOWN** buttons you can dial the digit of user password from 1 to 9 and can press the button "**WR/SEL**". If the password is

correct, the keyboard is unblocked. If after unblocking the keyboard no button is pressed within 15 s and setting of blocking has not been disabled by the user, the keyboard is blocked again.

5.3.4 Mode of **Minimum number of settings (MNS)**

Mode of **MNS** is designed to facilitate the work of the service personnel with UBZ.

In case of initial factory settings UBZ is in the mode of **MNS**.

When UBZ is operated in the mode of **MNS** the green led "**MMSP**" is on.

UBZ operation in **MNS** mode differs from UBZ operation in the mode of user level that the parameters not included in the list of **MNS** are set to factory defaults, and when you log in the user menu they are not visible.

Operation with parameters those are included in the list of **MNS** is the same as with the settings in the mode of user level (it.5.3.5).

When the mode of **MNS** is disabled (setting of parameter "Minimal set" is in "Off" position), the led "**MMSP**" goes out and UBZ switches to the user level. At the user level you can change all the settings (included and not included in the list of **MNS**), if the change is not disabled by the advanced user.

ATTENTION: If any programmable parameters have been changed by the user or the advanced user (at user level or advanced user level modes), but they are not included in the list of MNS, then when transfer to the mode of MNS instead these changes the factory settings will be restored.

Adding of any parameter in the list of MNS and disabling of MNS mode is possible only in advanced user level.

UBZ will transfer to the **MNS** mode after reset to factory settings (it.5.3.7).

5.3.5 Mode of **User level**

When UBZ unit is in the user-level mode, led "**MMSP**" is off.

To view and change the parameters of user level you should press the "**SETUP**" button, the led "**SETUP**" is on and the indicator displays the user menu (Fig.5.6).

```

USERS MODE
Real Time
>CT nominal i    500
Rated Inom      100
    
```

Fig.5.6 – User Menu

Using **DOWN** and **UP** buttons select the desired parameter (in Fig.5.6, "CT nom i" parameter is selected; it is the rated current of the CT) and press the "**SETUP**" button (Fig.5.7)

```

USERS MODE
>CT nominal i    500
ADV              MMSP
    
```

Note: Inscription "ADV" means that the parameter value change is possible only in the mode of **Advanced user level**. The inscription "**MMSP**" means that the parameter is included in the list of MNS.

Fig.5.7 – Screen of changing the setting in the user mode

If the fourth line of the indicator is marked by "ADV" (Fig. 5.7), the change of the parameter value in the user mode is disabled and in this case it can only be changed in the mode of **Advanced user level**.

If the parameter is not in the list of MNS (the fourth line of the indicator has the inscription "OFF MMSP"), then to change the value of the parameter it is necessary preliminary to include it in the list of MNS. To do this it is required the following:

- using **DOWN** and **UP** buttons select the parameter;
- press "**SETUP**" button;
- press simultaneously **DOWN** and **UP** buttons (on the display instead of the inscription "OFF MMSP" the inscription "MMSP" should remain).

The value of the parameter in the user mode can be changed if the fourth line of the indicator has only the inscription "MMSP". To do this it is required:

- using buttons **DOWN** or **UP** select the desired parameter value;
- using the button "**WR/SEL**", record the value of the parameter, and to go back to menu without recording, press the "**SETUP**" button.

If no button is pressed within 30 seconds, UBZ switches to the state of the viewing the measured and the calculated parameters.

To exit to menu before 30 seconds you need to press button **"WR/SEL"**.

5.3.6 Mode of **Advanced user level**

Access to the advanced user level

Press the **"SETUP"** button for 5 seconds, release the button.

If the level is password protected, the led **"SETUP"** is on and the display shows the PASSWORD inscription and "000" will flash (Fig.5.8).

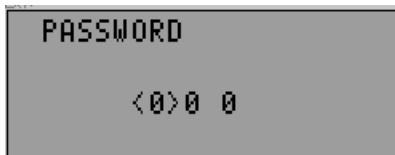

Fig.5.8 – Advanced user password

Using **UP** and **DOWN** buttons sequentially, enter the three-digit password of advanced user, from 1 to 9 and separate dialing with pressing the button **"WR/SEL"**. If the password is wrong, then LCD will display "ERROR" and after 15 seconds UBZ will return to the view state of the parameters, otherwise UBS will go to the advanced user level (Fig.5.9).

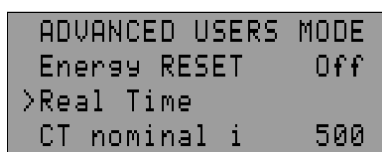

Fig.5.9 – Advanced user level

The procedure for changing the settings on the advanced user level is the same as user-level (it.5.3.5), but the parameter recording does not depend on the inscription "ADV" presence in the fourth line of the indicator. However, to change the value of the parameter, the parameter should be included in the list of MNS.

At the advanced user level the availability of any parameter at the user level can be disabled or enabled. To do this it is required the following:

- using **DOWN** and **UP** buttons, select the parameter (Fig.5.9);
- enter the menu where setting is changed by pressing **"SETUP"** button;
- press both buttons **"SETUP"** and **DOWN**.

In case of restricting access to change the parameter at the user level in the fourth line of the indicator the inscription "ADV" will display.

5.3.7 Factory settings

Factory settings are possible in two ways.

The first method: set the parameter "Default Factor" to "On"; after exiting from the mode for setting the factory settings will be restored.

This method does not recover the following settings:

- access code of advanced user ("Password");
- current time and date;
- clock correction ("Correct Time");
- the unit operating time ("Time UBZ");
- operating time of the motor ("Time motor").

The second method: when UBZ energizing, hold pressed for two seconds the buttons **"SETUP"** and **"WR/SEL"**. Factory settings are restored (advanced user password - 123).

This method does not recover the following settings:

- the unit operating time ("Time UBZ");
- operating time of the motor ("Time motor").
- clock correction ("Correct Time").

After you complete the installation of factory parameters, UBZ will start operation in the mode of MNS, the list of which the settings are included:

- CT output current, "CT out i";
- CT rated current, "CT nom i";
- motor rated current, "Rated Inom".

5.3.8 Real time setting

To set the real time it is necessary the following:

- 1) pressing **"SETUP"** button, enter the parameters setting mode;
- 2) using **UP** and **DOWN** buttons, select parameter "Real Time";
- 3) press the button **"SETUP"** (Fig.5.10);

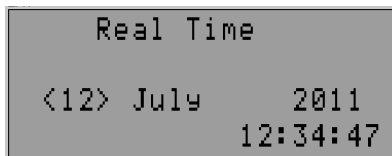

Fig.5.10 – View of the display when setting the time

- 4) using **UP** and **DOWN** buttons, select the desired date and press the button "**WR/SEL**" ;
- 5) repeat it. 4 to set the month, year, hour and minute.

When recording minutes (at the moment of pressing the button "**WR/SEL**"), the number of seconds will be automatically set to zero.

If you move to the next parameter without changes, instead of the button "**WR/SEL**", press the button "**SETUP**".

If no button is pressed for 15 seconds, UBZ will automatically switch to the parameter view mode.

5.3.9 UBZ faults reset on front panel

Fault reset is performed when the motor is off. To reset the faults on the front panel, press simultaneously the buttons "**SETUP**" and **DOWN**, in this case:

- faults are reset regardless of whether ARS is disabled or enabled (besides the current faults and faults by the presence of motor currents when load relay is off);
- counting of ARS is off;
- in the absence of the current troubles the motor is off.

5.3.10 Energy meters reset

Reset of energy meters (total, active and reactive) is performed when setting the parameter "Energy RESET" to "On" (setting to "1" when using RS-232/RS-485 interface). After reset of energy meters, the parameter "Energy RESET" will automatically switch to "Off" ("0" – when reading the parameter via RS-232/RS-485 interface).

5.4 UBZ Operation

In describing the operation of UBZ it is assumed that this protection is enabled and all the required sensors are connected.

5.4.1 UBZ operation before load relay on

5.4.1.1 UBZ operation after energizing (first start-up)

After energizing the indicator displays the device name, the version number of software, the name of the manufacturer and the operation performed (Fig.5.11).



Note – the software version number may vary.

Fig.5.11 – UBZ indicator view after energizing

After 1-2 seconds the indicator will display the values of the measured parameters. What parameters will be displayed on the indicator it depends on the value of the parameter "Indicat <Start>":

- line voltages at "Indicat <Start>="LineU";
- the motor operating time, the insulation resistance of the motor and mains frequency at "Indicat <Start>="InsFr".

Before the load relay enabling UBZ checks the following:

- the level of stator winding insulation relative to the motor housing (when insulation resistance is less than 500 ± 20 kOhm at "Insulation Mr" = "5" (1000 ± 50 kOhm at "Insulation Mr" = "10") the load is not enabled);
- the quality of the mains voltage: full phase, symmetry, the current line voltage value;
- correct phase sequence, the lack of their "coincidence".

If any of disabling factors, the load relay is not activated, and the display of mnemonics shows the corresponding message about the fault (Table 5.12) and the led "**FAULT**" lights up.

In the absence of disabling factors, enabling the load relay is determined by the value of parameter "Start>Power" (UBZ operation after energizing):

- 1) when "Start>Power" = "StOff", the load relay will not be enabled.

To enable the load relay in this case, you should simultaneously press UP and DOWN buttons.

- 2) when "Start>Power" = "St>AR" the load relay will be enabled after ARS time.
 - 3) when "Start>Power" = "St>2s" the load relay will be enabled within 2 seconds after energizing.
- Simultaneously with the load relay enabling the green led "Power relay" lights up.

After you activate the relay and up to the moment of the motor starting (motor start is determined by the excess of the load current of 120% level of rated current), control and taking action on voltage quality is maintained. If within no-current pause the disabling factors are appeared, the load relay is deactivated.

UBZ operation when enabled remote control of the motor via RS-232/RS-485 interface (parameter "MotorOp RS-2/5") is considered in it. 5.6.9.

5.4.1.2 UBZ operation after shutdown owing to the fault

UBZ operation in this case is similar to the work when first starting, but enabling the load relay does not depend on the value of the parameter "Start>Power".

If after the fault ARS is disabled ("AR"="Off"), then with disabled motor start on the front panel (it is determined by the value of the parameter "MotorOp UBZ") the automatic enabling the motor is impossible up to UBZ turning off. The action of the parameter "AR" value is applied to all types of faults except voltage faults. To disable ARS in case of voltage faults you should use the parameters "Umax protec", "Umin protec", "Uimbal protec".

5.4.2 UBZ operation after load relay enabling and motor is on (currents occurrence more than 10% of the motor rated current)

UBZ provides monitoring for voltage and currents. The load relay is disabled when any protection tripping from Table 5.12 with the exception of:

- voltage protection;
- overcurrent protection with "Imax<>T" ="Ind" (in this case, the warning is there, but the load relay is not disabled).

The indicator can display phase currents of motor or group of three (two) parameters selected by the user (Table 2.5). The group of parameters selected by the user can be displayed constantly ("Indicat mode" ="Conti") or for 15 s, and then indication of motor currents returns ("Indicat mode" =">15s").

5.4.3 Functional relay operation

The functions performed by the functional relay are determined by the parameter "Relay F mode".

When "Relay F mode" = "Alarm", the relay is used as alarm relay (LEDs "Λ/Δ" and "TR" do not on). The relay contacts are closed when there is any fault specified in Table 5.12.

When "Relay F mode" = "Timer", the relay is used as time relay (LED "TR" is on): it turns on after the time set by the parameter "Relay F time", after the load relay enabling.

When "Relay F mode" = "St->D", the relay is used to switch the motor windings from star to delta (LED "Λ/Δ" is on). In this mode the load relay is activated the same way as in the mode "Alarm", but after the time set by parameter "Relay F time" it is disabled. After the time set by the parameter "Delay RP RF", after the load relay is off, the functional relay is activated.

Note – When the functional relay is enabled, the contacts **13-14** are open, and contacts **14-15** closed.

5.5 Operation of UBZ-305 together with computer

5.5.1 Communication protocol and interface

The communication between UBZ and computer can be via RS-232 or RS-485 interface (parameter "Communication").

For communication MODBUS Protocol is used in **RTU** mode or MODBUS in **ASCII** mode (parameter "ASCII-RTU").

In ASCII mode 8-bit data is the combination of two ASCII characters (Table. 5.1). For example, 1 –data byte: 64 Hex, in ASCII consists of two characters '6' (36 Hex) and '4' (34 Hex).

Table 5.1

Character	'0'	'1'	'2'	'3'	'4'	'5'	'6'	'7'
ASCII code	30 Hex	31 Hex	32 Hex	33 Hex	34 Hex	35 Hex	36 Hex	37 Hex
Character	'8'	'9'	'A'	'B'	'C'	'D'	'E'	'F'
ASCII code	38 Hex	39 Hex	41 Hex	42 Hex	43 Hex	44 Hex	45 Hex	46 Hex

In **RTU** mode 8-bit data is the combination of 4-bit hexadecimal digits. For example, 64 Hex.

During data exchange via RS-485 or RS-232 the blue LED "↔" is on.

Diagram of UBZ connection to computer is shown in Fig.5.12.

Each UBZ has the individual communication address. The computer controls each UBZ recognizing them by their addresses.

5.5.2 Communication parameters:

- the unit address: 1-247 (parameter "Address UBZ");
- data transfer rate: 9600 baud, 19200 baud (parameter "Data speed");
- reaction to loss of connection: the continuation of operation with no warning, the warning and continued operation, the warning and stopping the motor with ARS enabling after restoration of communication, warning and motor stop with ARS disabling (parameter "Loss connect");
- detection of exceeded time for reply: 1s – 120s (parameter "Overexceeding").

The format of the transmitted word is the following:

- 8 data bits in RTU mode and 7 data bits in ASCII mode;
- parity check (parameter "Even parity"): disabled ("Off"), enabled ("On"); (factory setting is "Off");
- number of stop bits (parameter "Stop bit"): 1 or 2 (factory setting is 2).

ATTENTION! CHANGES OF THE COMMUNICATION SETTINGS (EXCEPT THE UNIT ADDRESS) WILL BE EFFECTIVE ONLY AFTER DE-ENERGIZATION OF UBZ-305 OR AFTER FULFILLMENT OF THE COMMAND "UBZ RESTART" ("RESTART") (it.5.5.11).

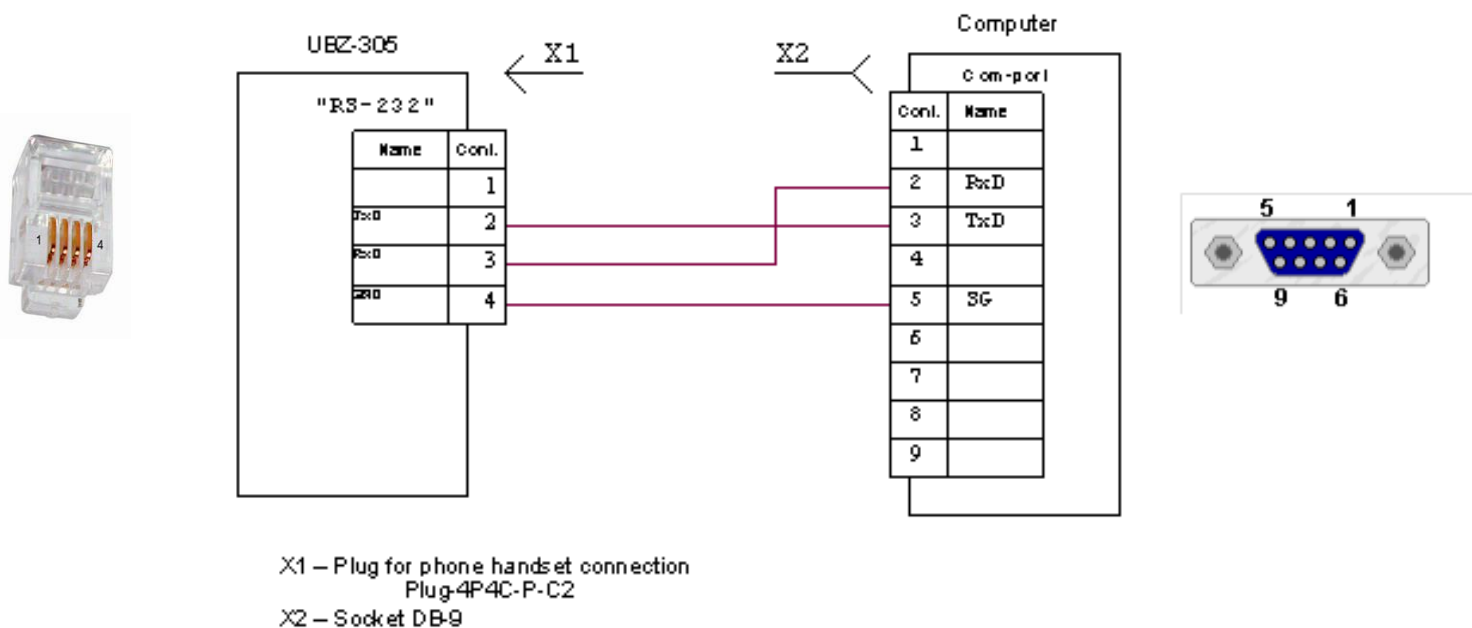

Fig.5.12 – Diagram of UBZ connection to computer

5.5.3 Communication protocol

Exchange between PC and UBZ is carried by data packets. Data packet format in **RTU** mode is shown in Table 5.2 and in **ASCII** mode – In Table 5.3.

Table 5.2 – Data packet in **RTU** mode

Name	Description
START	Silence interval – over 4 ms at transmission rate of 9600 baud, or more 2 ms at transmission rate of 19200 baud
ADR	UBZ communication address (8 bit)
CMD	Command code 8 bit
DATA 0	Content of data: N*8 bit data (n<=24)
....	
DATA (n-1)	
CRC CHK low	CRC – Cyclic Redundant Check 16 bit
CRC CHK high	
END	Silence interval – over 4 ms at transmission rate of 9600 baud, or more 2 ms at transmission rate of 19200 baud

Table 5.3 – Data packet in ASCII mode

Name	Description
STX	Start character ':' (3A Hex)
ADR1	UBZ communication address (8 bit) consisting of two ASCII characters
ADR0	
CMD1	Command code 8 bit consisting of two ASCII characters
CMD0	
DATA 0	Content of data: N*8 bit data (n<=24) consisting of two ASCII characters
....	
DATA (n-1)	
LRC CHK 1	LRC Cyclic Redundant Check: 8-bit control total consisting of two ASCII characters
LRC CHK 0	
END1	The end of characters: END1= 0D Hex – carriage return (CR); END0 = 0A Hex – line feed (LF)
END0	

5.5.4 Command codes

5.5.4.1 General

The format of data characters depends on command codes. Examples of transmission of commands and data are given for **RTU** mode. For **ASCII** mode the command codes are not changed, but the format of the transmission data and control of data is based on the Table 5.3.

5.5.4.2 Command for reading the register group

Command code – 0x03, reading n-words

For example, reading of continuous 2 words from starting address 2102H in UBZ with communication address 01H in **RTU** mode (Table 5.4) and in **ASCII** mode (Table 5.5)

Note – In UBZ during fulfillment of one command 12 registers (n=12) are possible to be read.

Table 5.4

Command message		Response message	
ADR	0x01	ADR	0x01
CMD	0x03	CMD	0x03
Start address of data	0x21 0x02	Number of data in bytes	0x04
Number of data in words	0x00 0x02	Content of data at address	0x17 0x70
CRC CHK low	0x6F	Content of data at address	0x00 0x00
CRC CHK high	0xF7	CRC CHK low	0xFE
		CRC CHK high	0x5C

Table 5.5

Command message		Code transferred, HEX	Numbers for LRC, HEX
STX	:	3A	
ADR	'0'	30	01
	'1'	31	
CMD	'0'	30	03
	'3'	33	
Start address of data	'2'	32	21
	'1'	31	
	'0'	30	02
'2'	32		
Number of data in words	'0'	30	00
	'0'	30	
	'0'	30	02
	'2'	32	
LRC CHK 1	'D'	44	
LRC CHK 0	'6'	36	
END1	CR	0D	
END2	LF	0A	

5.5.4.3 Command of register entries

Command code – 0x06, record – one word

This command is not recommended, as the entry of incorrect data may lead to failure of UBZ.

Data recording is possible at the addresses of programmable parameters (Table 2.5), except the parameters listed in Table 5.6.

The parameter recording is independent of set protection of the advanced user (entry by the communication line has higher priority).

When recording new value of the parameter into the cell protected by MNS, the parameter is automatically removed from this mode.

Table 5.6

Settings and readings	Displaying	Address
Total time of the unit operation, day	Time UBZ	217
Motor operating time, day	Time motor	218
Access code of user	Users code	219
Access code of advanced user	Password	220
Restoration of factory settings	Default Factor	221
The unit design version	Version	230

Example: recoding order is 1000 (0x03E8) to register with address 0x00A0 to UBZ with communication address 01H in RTU mode is shown in Table 5.7.

Table 5.7

Command message		Response message	
ADR	0x01	ADR	0x01
CMD	0x06	CMD	0x06
Start address of data	0x00 0xA0	Start address of data	0x00 0xA0
Data	0x03 0xE8	Data	0x03 0xE8
CRC CHK low	0x89	CRC CHK low	0x89
CRC CHK high	0x56	CRC CHK high	0x56

5.5.4.4 Command for diagnostics

Command code 08h – diagnostics

The 08h function provides a number of tests for checking the communication system between PC and UBZ, and UBZ serviceability control.

The function uses the sub-function field to specify the action performed (test).

Sub-function 00h - return of request data

The data transmitted in the data field of the request should be returned in the response data field.

Example of request and response for MODBUS RTU mode is shown in Fig.5.13.

Request

Address	Function	Sub-function HB	Sub-function LB	Data HB	Data LB	CRC LB	CRC HB
01h	08h	00h	00h	A0h	3Ch	98h	1Ah

Response

Address	Function	Sub-function HB	Sub-function LB	Data HB	Data LB	CRC LB	CRC HB
01h	08h	00h	00h	A0h	3Ch	98h	1Ah

Fig.5.13 – Example of request and response for sub-function 00h – return of request data

Sub-function 01h – restart of communication options

During fulfillment of the command UBZ performs only change in baud rate. To change totally the communication settings you should run the command "UBZ RESTART" ("RESTART").

Example of request and response for MODBUS RTU mode is shown in Fig.5.14.

Request

Address	Function	Sub-function HB	Sub-function LB	Data HB	Data LB	CRC LB	CRC HB
01h	08h	00h	01h	00h	00h	B1h	CBh

Response is not returned

Fig.5.14 – Example of request and response for sub-function 01h – restart of communication options

5.5.5 Control of correct transmission of data packet

5.5.5.1 Control of correct transmission of data packet in **RTU** mode

To check the correctness of data transmission in **RTU** mode the CRC Cyclic Redundant Check – the code for cyclic control is used.

The Cyclic Redundant Check (CRC16) is a cyclic verification code based on the polynomial A001h. The transmitting device forms the Cyclic Redundant Check for all bytes of the message transmitted. The receiving device similarly generates the Cyclic Redundant Check for all bytes of the message received and compares it with the Cyclic Redundant Check received from the transmitting device. In case of mismatching the generated and received Cyclic Redundant Check the error message will be generated.

The field of Cyclic Redundant Check has two bytes. CRC in the message is transferred with low byte first.

CRC is formed by the following algorithm:

- 1) loading CRC register (16 bit) by units (FFFFh);
- 2) exclusive OR with the first 8 bits of the byte of the message and CRC register contents;
- 3) shift of the result one bit to the right;
- 4) if shifted bit = 1, exclusive OR of the contents of the register with value A001h;
- 5) if shifted bit = 0, repeat step 3;
- 6) repeat steps 3, 4, 5, until 8 shifts;
- 7) exclusive OR with the following 8 bits byte of the message and CRC register contents;
- 8) repeat steps 3 to 7 until all bytes of the message will be processed;
- 9) the final contents of the register will contain the CRC.

Example of Program CRC code generation in the language C. the Function has two arguments:

Unsigned char* data <- a pointer to the message buffer

Unsigned char length <- the quantity of bytes in the message buffer

The function returns the CRC value as a type of unsigned integer.

Unsigned int crc_chk(unsigned char* data, unsigned char length)

```
{int j;
unsigned int reg_crc=0xFFFF;
while(length--)
{
    reg_crc ^= *data++;
    for(j=0;j<8;j++)
    {
        if(reg_crc & 0x01) reg_crc=(reg_crc>>1) ^ 0xA001; // LSB(b0)=1
        else reg_crc=reg_crc>>1;
    }
}
return reg_crc;
}
```

5.5.5.2 Control of correct transmission of data packet in ASCII mode

To check the correctness of data transfer in **ASCII** mode LRC Redundant Check – longitudinal redundancy check. CRC is 8 – bit number transmitted as two ASCII characters. The CRC is formed by inverse transformation of all ASCII characters in eight-bit binary numbers (direct conversion it.5.6.1), the addition of these numbers without accounting for the transfer, and the calculation of additional code of the received number. At the receiver, the LRC is calculated again and compared with the received LRC. In the calculation of LRC the colon, CR and LF are discarded.

An example of the LRC calculation for the command for reading of continuous 2 words from starting address 2102H in UBZ with communication address 01H is shown in Table 5.5.

5.5.6 Register addresses

The register addresses of measured and calculated parameters of UBZ are given in Table 2.5

The register addresses of programmable parameters are given in Table 2.6.

The register addresses of special and service parameters and their purpose are given in Table 2.4.

The register address of the status and purpose bit data in Table 5.8.

The register addresses of the alarm log are given in Table 5.8.

The register addresses of time settings are given in Table 5.9.

The register address of commands is 903 (Table 5.11).

Table 5.8

Description	Address	Service	Remark	
Register of UBZ state	900	Bit 0	0 – No fault; 1 – fault (code of fault in register - 241).	
		Bit 1	0 – load relay is disabled; 1 – load relay is enable.	
		Bit 2	0 – functional relay is disabled; 1 – functional relay is enabled.	
		Bit 3	0 – restart is disabled; 1 – ARS is waited.	
		Bit 5-4	Mode of functional relay operation: 00 – alarm relay; 01 – time relay; 10 – star / delta.	
		Bit 6	0 – MNS mode is disabled; 1 – MNS mode is enabled.	
		Bit 7	0 – clock battery is normal; 1 – the clock battery should be replaced.	
		Bit 8	0 – normal operation; 1 – UBZ is in area of hysteresis when operating with analog inputs.	
Register of fault 1	901	Bit service as per Table 5.12.	0- no fault; 1- fault.	
Register of fault 2	902	Bit service as per Table 5.12.		
Fault logbook				
Fault code 1	1000	Fault code as per Table 5.12.		
Parameter value 1	1001	Parameter value as per Table 5.12.		
Fault time 1	1002	Low byte – seconds, high byte – minutes.		
	1003	Low byte – hours, high byte – day of month.		
	1004	Low byte – month, high byte – (year minus 2000).		
Fault code N	$1000+(N-1)*5$	Fault code as per Table 5.12.		
Parameter value N	$1000+(N-1)*5+1$	Parameter value as per Table 5.12.		
Fault time N	$1000+(N-1)*5+2$	Low byte – seconds, high byte – minutes.		
	$1000+(N-1)*5+3$	Low byte – hours, high byte – day of month.		
	$1000+(N-1)*5+4$	Low byte – month, high byte – (year minus 2000).		

Note – At the time of UBZ delivery or after the setting of factory parameters (it.5.4.7) there is a record in the fault logbook about error code 40 and parameter value 10000.

5.5.7 Time parameter registers

The parameters are transmitted in binary decimal code. For example, the code 0x14 in the register of minutes means 14 minutes.

Registers of time settings allow reading and recording of data.

Register addresses for time settings are shown in Table 5.9.

Table 5.9

Parameter	Address	Remark
Seconds	80	
Minutes	81	
Hours	82	
Day	83	
Month	84	
Year	85	Last two digits of the current century are recorded (read) in the register

5.5.8 Communication errors handling

In case of erroneous situation when making the frame (parity error, frame error, checksum error) UBZ returns no reply.

In the event of an error in the format or value of data transferred (unsupported function code, etc.) UBZ accepts the request frame and builds a response with a symptom and error code. The error indicator is the high

bit set to one in the function field. For the error code there is separate field in the response. Response example is given in Fig. 5.15. Error codes are listed in Table 5.10.

Request – Function 30h is not maintained

Address	Function	Data	CRC LB	CRC HB
01h	30h		XXh	XXh

Response

Address	Function	Error code	CRC LB	CRC HB
01h	B0h	01h	94h	00h

Fig.5.15 – Example of the response after error occurs

Table 5.10 – Error codes

Error code	Name	Description
01h	ILLEGAL FUNCTION	Received the function code cannot be processed by UBZ
02h	ILLEGAL DATA ADDRESS	The data address specified in the request is not available to this slave
03h	ILLEGAL DATA VALUE	The value contained in the request data field is disabled value for UBZ
04h	SLAVE DEVICE FAILURE	While UBZ attempted to perform the requested action, unrecoverable error occurred
05h	ACKNOWLEDGE	UBZ accepted the request and is processing it, but this takes much time. This response prevents master from generating timeout errors
06h	SLAVE DEVICE BUSY	UBZ is busy of processing a command. The master should repeat the message later when the slave is freed
07h	NEGATIVE ACKNOWLEDGE	UBZ cannot perform the program function received in request

5.5.9 Remote control of the motor using RS-232/RS-485 interface

UBZ operation in remote control mode is determined by parameter “MotorOp RS-2/5”:

When “MotorOp RS-2/5” equal to “Off” (0) – remote control of the motor is disabled.

With activated remote control (parameter “MotorOp RS-2/5” equal to “OnSta”(1) or “OffSta” (2)), motor start on the front panel is disabled regardless of the value of the parameters "MotorOpUBZ" and "Start>power".

When “MotorOp RS-2/5” equal to “OnSta” – after energizing UBZ operates in the same way as when the remote control is disabled (normal device operation), but it is enabled to record to the command register R_COMMAND. Automatic motor start is possible only after ARS time.

When “MotorOp RS-2/5” equal to "OffSta" – UBZ will start the motor only after the receipt of the respective command via RS-232/RS-485 interface.

The value R_COMMAND is taken into account by UBZ operation algorithm when “MotorOp RS-2/5” =“OnSta” and “MotorOp RS-2/5” = “OffSta”. If “MotorOp RS-2/5” = “Off” and the user sets “MotorOp RS-2/5” “OnSta” or “MotorOp RS-2/5” = “OffSta”, then in R_COMMAND zero (0) will be recorded.

The list of possible register setup of commands is shown in Table 5.11.

When “MotorOp RS-2/5” = “OnSta”, then after energizing in the command register 1 is recorded (normal device operation).

When “MotorOp RS-2/5” = “OffSta”, then after energizing in the command register 0 is recorded (motor is disabled prior to entering the command to enable).

In case of emergency shutdown of the motor by simultaneously pressing DOWN, UP (when "MotorOp UBZ" = 2 ("Stop") or "MotorOp UBZ" = 3 ("St<>"), 0 will be reset in the command register.

Table 5.11 – Values of command register

Command register R_COMMAND Address = 903	Action fulfilled
0	Turn off the motor. If the motor is turned off, before receiving a command from the remote control to turn on the motor will not turn on. If the motor is on, the motor will be off.
1	Normal operation of the device. If the motor has been disabled by the command of the remote control or by simultaneous pressing DOWN , UP when "MotorOp UBZ" = 3 ("St<>") or when fault occurs, after which ARS is possible, then enabling the motor when 1 record to R_COMMAND will happen after ARS time from the moment the motor is turned off.
2	The early motor switching on. Record 2 turns on the motor before the ARS time finishes. After the motor enabling R_COMMAND =1.
55 (37 Hex)	Command "FAULT RESET" (it.5.6.10)
88 (58 Hex)	Command "UBZ RESTART" ("RESTART") (it.5.6.11)

5.5.10 Command "FAULT RESET"

Command "FAULT RESET" is fulfilled after recording the command code 55 in the command register (Table 5.11) via RS-232/RS-485 interface.

When the command is fulfilled:

- all faults are reset (whether ARS is disabled or enabled);
- ARS count ends;
- if there is no current fault, the motor is enabled.

5.5.11 Command "UBZ RESTART" ("RESTART")

Command "UBZ RESTART" is used for entering into effect of the changed parameters of communication.

Command "UBZ RESTART" is fulfilled after record of command code 88 in the command register (Table 5.11) via RS-232/RS-485 interface. After receiving Command "UBZ RESTART", UBZ does not return confirmation of received command.

WARNING: Between the last address to the registers of UBZ-305 and recording of the command "UBZ RESTART" the delay of at least 100 ms should be provided.

ATTENTION! WHEN THE MOTOR IS ENABLED THE FULFILLMENT OF COMMAND "UBZ RESTART" ("RESTART") IS DISABLED.

5.5.12 UBZ factory settings using MODBUS interface

To do this, you need to set the parameter "Default Factor" = 1. In this case the operation parameters of the serial interface will not change (reset of interface settings to factory settings is not performed). The execution time of reset to the factory setting is to 5 seconds. After the operation finished the parameter "Default Factor"=0.

ATTENTION! WHEN THE MOTOR IS ENABLED SETTING OF FACTORY PARAMETERS VIA MODBUS INTERFACE IS DISABLED.

RECORDING OF PARAMETERS VIA MODBUS INTERFACE PRIOR TO COMPRETION OF RESET OPERATION IS DISABLED.

5.6 Emergency Conditions System

In case of emergency state of UBZ:

- in the fourth line of the indicator the alarm message displays (Fig. 5.16) (fault code corresponds to Table 5.12);

Line U1, V	345
Line U2, V	312
Line U3, V	210
I _{max}	Er 3: 8

Fig.5.16 – UBZ Indicator in mode of view for measured and calculated parameters (if there is a fault)

- red LED "**FAULT**" is on (with constant light if ARS is disabled and with flashing, if ARS is expected);
- the load relay is disabled;
- functional relay is activated (when "Relay F Mode" = "Alarm").

If UBZ defines several different types of faults at the same time, the codes of faults and parameter values are displayed sequentially, one by one (on the indicator the number of displayed fault is changed).

If ARS is enabled, then in the fourth line of the indicator alternately the codes of faults and the time in seconds remaining until ARS are shown (Fig. 5.17) (if the waiting time for thermal overload of the motor is more than the ARS time, then the waiting time is displayed). If ARS is disabled, the state of ARS in the third line is not displayed.

```
Line U1, U      342
Line U2, U      345
Line U3, U      339
AR=350
```

Fig.5.17 – Indicator when displaying the time remaining until ARS

Table 5.12 – Fault codes

Fault description	Fault mnemonics	Parameter value	Register address of parameter value	Fault code	Register address of faults for N bit
Maximum phase current	I max	Maximum phase current	300	0	901:0
Thermal overload	Thermal over		301	1	901:1
Ground fault (zero sequence current)	learth	Zero sequence current	302	2	901:2
Excess ratio of negative sequence current to negative sequence voltage	Coef I/U	Coefficient of negative sequence current *100	303	3	901:3
Negative sequence current	I2 rev	Negative sequence current	304	4	901:4
Minimum phase current	I min		305	5	901:5
Delayed start	LongStart	Current	306	6	901:6
Rotor blocking	Block Rot	Current	307	7	901:7
Upon reaching the temperature threshold of the first transmitter	Temp1	Temperature in degrees	308	8	901:8
Upon reaching the temperature threshold of the second transmitter	Temp2	Temperature in degrees	309	9	901:9
Phase sequence	PhaseSequen		310	10	901:10
External MS (the presence of currents when load relay is disabled)	Contactor	Current	311	11	901:11
At minimum line voltage	U min	Voltage	312	12	901:12
At maximum line voltage	U max	Voltage	313	13	901:13
At phase imbalance	Uimbal	Imbalance	314	14	901:14
Minimum insulation resistance of motor winding	Insul Res	Insulation resistance	315	15	901:15
Mains minimum frequency	F min	Frequency	316	16	902:0
Mains maximum frequency	F max	Frequency	317	17	902:1
Fault of remote control channel	RemoteCont			18	902:2
Motor emergency shutdown without possibility for restart	Stop nAR			19	902:3
Motor emergency shutdown with possibility to restart by simultaneously pressing the buttons UP and DOWN	Stop Motor			20	902:4
s.c. of temperature transmitter 1	ShortTempS1			21	902:5
Breakout of temperature transmitter 1	BreakTempS1			22	902:6

Table 5.12 (Continued)

Fault description	Fault mnemonics	Parameter value	Register address of parameter value	Fault code	Register address of faults for N bit
s.c. of temperature transmitter 2	ShortTempS2			23	902:7
Breakout of temperature transmitter 2	BreakTempS2			24	902:8
Loss of phase	Break Phase			25	902:9
EEPROM destruction	Error EEPROM			26	902:10
At analog input "0-20 mA"	Input I		327	27	902:11
At analog input "0-10 V"	Input U		328	28	902:12
Improper calibration	Error CALIB			29	902:13

Notes:

1 – Occurrence of fault as "EEPROM Error" – the destruction of EEPROM indicates that the data of the programmed parameters (Table 2.6) is damaged. To continue the operation, it is necessary to turn off UBZ and restore the factory settings (5.4.7 – second method).

2 – Occurrence of fault as "Error CALIB" – UBZ improper calibration means that the calibration coefficients of the measured data are damaged. The continued operation of UBZ is impossible. Re-calibration of the device is required to be done at the manufacturer factory.

5.7 Emergency Conditions Logbook

When disabling the load relay in the event of fault, UBZ records in its memory the code of the fault, the value of the parameter on which the fault occurred and time of occurrence.

Note – The fault time is determined by internal clock of UBZ.

Number of simultaneously stored fault codes is 50. In case of subsequent faults occur, the fault information is recorded in place of the oldest fault

To view the log, it is necessary to press button "**WR/SEL**".

LED "**SETUP**" will on in flashing mode, and UBZ indicators will display the latest fault (Fig.5.18).

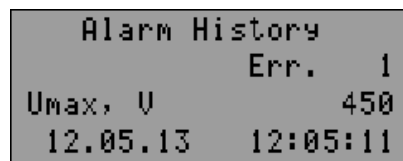

Line 1 – indication of mode (alarm logbook);

Line 2 – number of the fault (1 – means the most recent fault);

Line 3 – mnemonic of the fault as per Table 5.12 and the parameter value at the moment of the fault occurrence;

Line 4 – time and date of the fault.

Fig.5.18 – Display in the view mode of the fault logbook

View the fault logbook by pressing the **UP** or **DOWN** button.

To exit the view log mode, press the button "**WR/SEL**" or exit will be automatically in 30 seconds after the last pressing of any button.

Register addresses to read data log of faults via MODBUS Protocol are given in Table 5.8.

5.8 Motor control on UBZ front panel

Depending on the value of the parameter "MotorOp UBZ", you can control the load relay of UBZ by simultaneously pressing the **UP** and **DOWN** buttons:

- "Off" - no reaction;
- "Start" (motor start is enabled) - the load relay will enabled if ARS time has not finished;

- "Stop" (motor emergency shutdown) - the load relay will disabled with the issuance of fault code "Stop nAR"). The restart of the motor is possible only after de-energizing and re-energizing of UBZ unit;
- "St<>" (motor start and shutdown is permitted) - the load relay is disabled with issuance of code "Stop Motor". To enable it, press again UP and DOWN buttons.

Note – in case of selection of parameter "Start>power"= "StaOff " (after energizing, start of the motor manually on the front panel of UBZ) and "MotorOp UBZ"= "Off" (the motor control manually is disabled) the load relay will not turn on.

5.9 Motor control using analog inputs

The motor control algorithms by the analog inputs "0-20 mA" and "0-10 V" are shown in Table 2.6.

After the motor stopping according to emergency level the countdown for ARS will only start after going out the parameter value of the emergency zone.

If after the motor switching off by the alarm level the parameter value is between the levels on and off for the motor, then:

- indicator "Power relay" blinks;
- indicator "FAULT" is off;
- the fault code is displayed on LCD.

Note – In this state of UBZ it is possible to do early motor enabling by buttons on the front panel or by remote control.

6 COMPONENTS

Delivery set is given in Table 6.1.

Table 6.1 – Delivery Set

Description	QTY
UBZ-305 Unit	1
Fasteners	2
Rubber gasket	1
Differential transformer (zero sequence transformer) *	1
Cable for communication with PC via RS-232 (type - KC-01)*	1
Temperature transmitter (types: Pt100, Ni100, Ni120) *	
*It is delivered upon agreement with the Customer.	

7 MAINTENANCE

7.1 SAFETY PRECAUTIONS



TO ENSURE SAFE OPERATION OF THE UNIT IT IS STRICTLY FORBIDDEN:

- **TO PERFORM MAINTENANCE WITHOUT THE UNIT DISCONNECTION FROM THE SUPPLY MAINS;**
- **TO OPEN AND REPAIR THE UNIT INDEPENDENTLY;**

It is not allowed to clean the unit with abrasive materials or organic compounds (alcohol, gasoline, solvents, etc.).

7.2 Maintenance of the unit should be performed by persons admitted to the operation and have the appropriate permission. The recommended frequency of maintenance is every six months.

7.3 Maintenance Procedure:

- 1) check the wires connection reliability, if necessary – clamp with force as specified in Table 2.1;
- 2) check visually the housing integrity;
- 3) if necessary, wipe with cloth the front panel and the unit housing.

8 TRANSPORTATION AND STORAGE

UBZ-305 in the original package of the Manufacturer should be stored indoors with temperature from minus 45 to +60°C and relative humidity of not more than 80% in the absence of vapors harmfully acting on the packaging and materials of the device.

During transportation of UBZ-305, the consumer should protect the unit from mechanical damage.

9 SERVICE LIFE, SHELF LIFE AND MANUFACTURER WARRANTY

9.1 The unit service life is 10 years. Upon expiration of the service life you should contact the Manufacturer.

9.2 Shelf life is 3 years.

9.3 Warranty period of the unit operation is 5 years from the date of sale.

During the warranty period the Manufacturer is responsible for free repair of the unit, if the Consumer has

complied with the requirements of this Operation Manual.

ATTENTION!

IF THE UNIT HAS BEEN OPERATED WITH VIOLATION OF THE REQUIREMENTS OF THIS OPERATION MANUAL, THE MANUFACTURER HAS THE RIGHT TO REFUSE WARRANTY SERVICE.

9.4 Warranty service is performed at the place of purchase or by the Manufacturer of the product.

9.5 Post-warranty service is performed by the Manufacturer at current rates.

9.6 Before sending for repair, the unit should be packed in the original or other packaging excluding mechanical damage.

Earnest request: when returning the unit or transfer for warranty or post-warranty service, in the fields for claims please indicate in details the reason for return.

Appendix A

CURRENT PROTECTION WITH DEPENDENT TIME DELAY

(mandatory)

Curve of standard inverse-definite time delay SIT

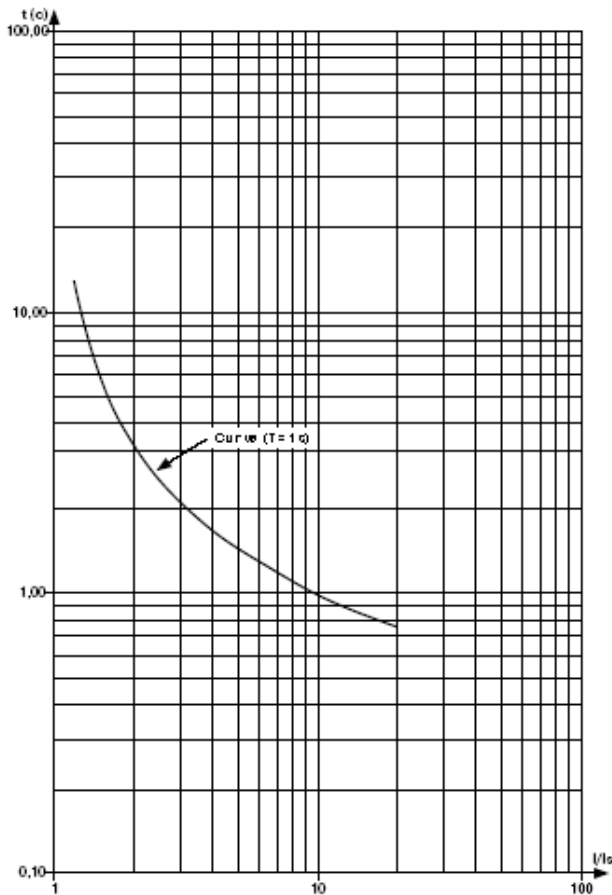

Curve of very inverse-definite time delay VIT or long-continued inverse-definite time delay LTI

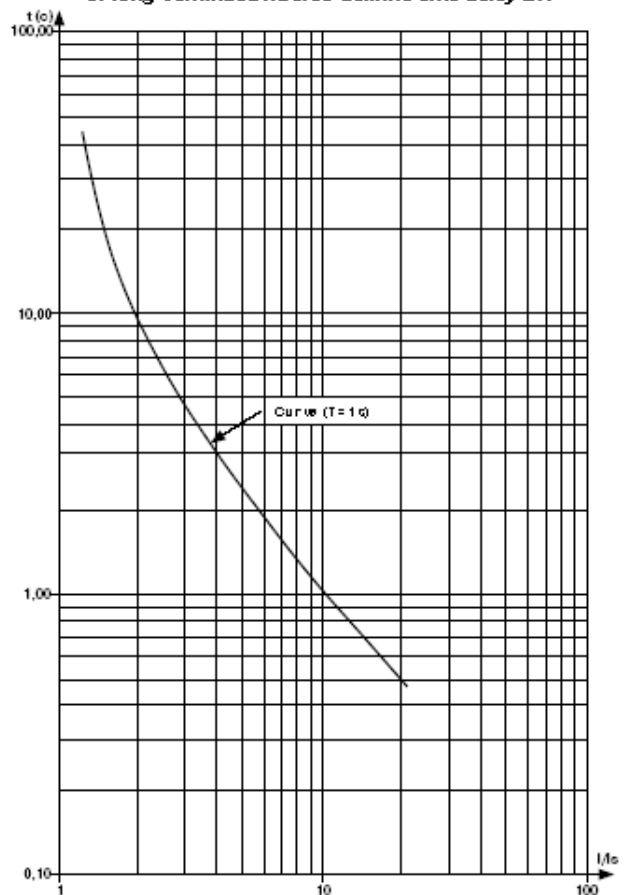

Curve of extremely inverse-definite time delay EIT

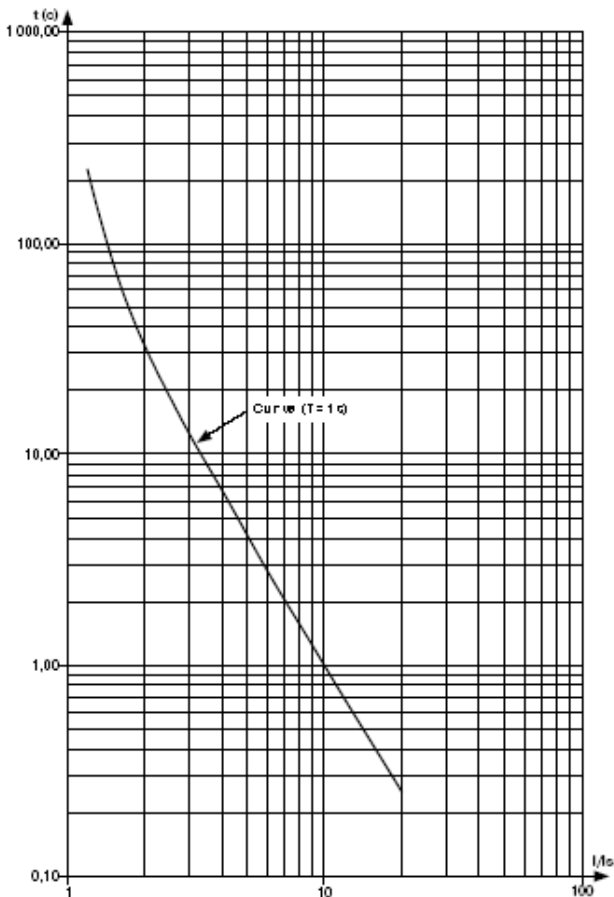

Curve of ultra inverse-definite time delay UIT

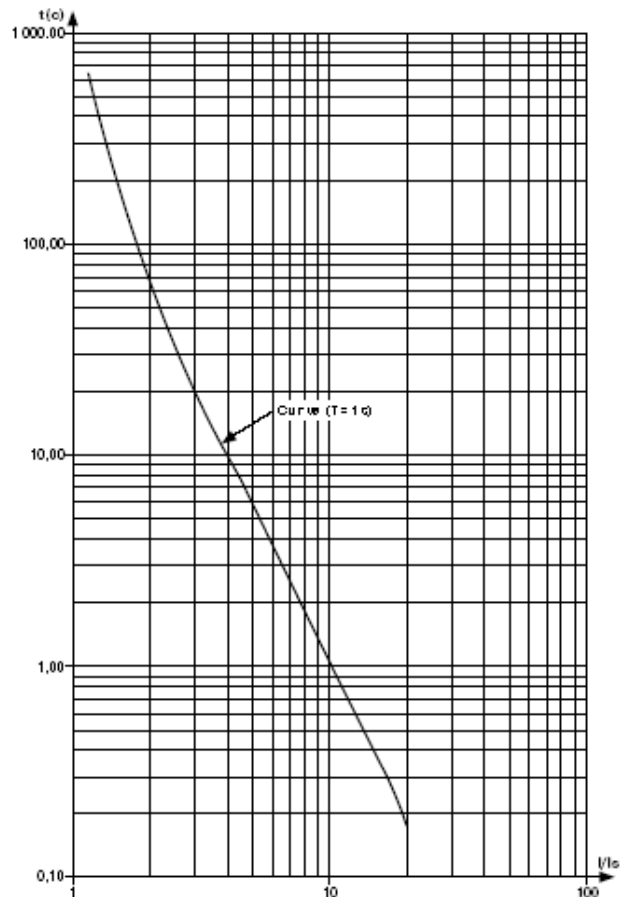

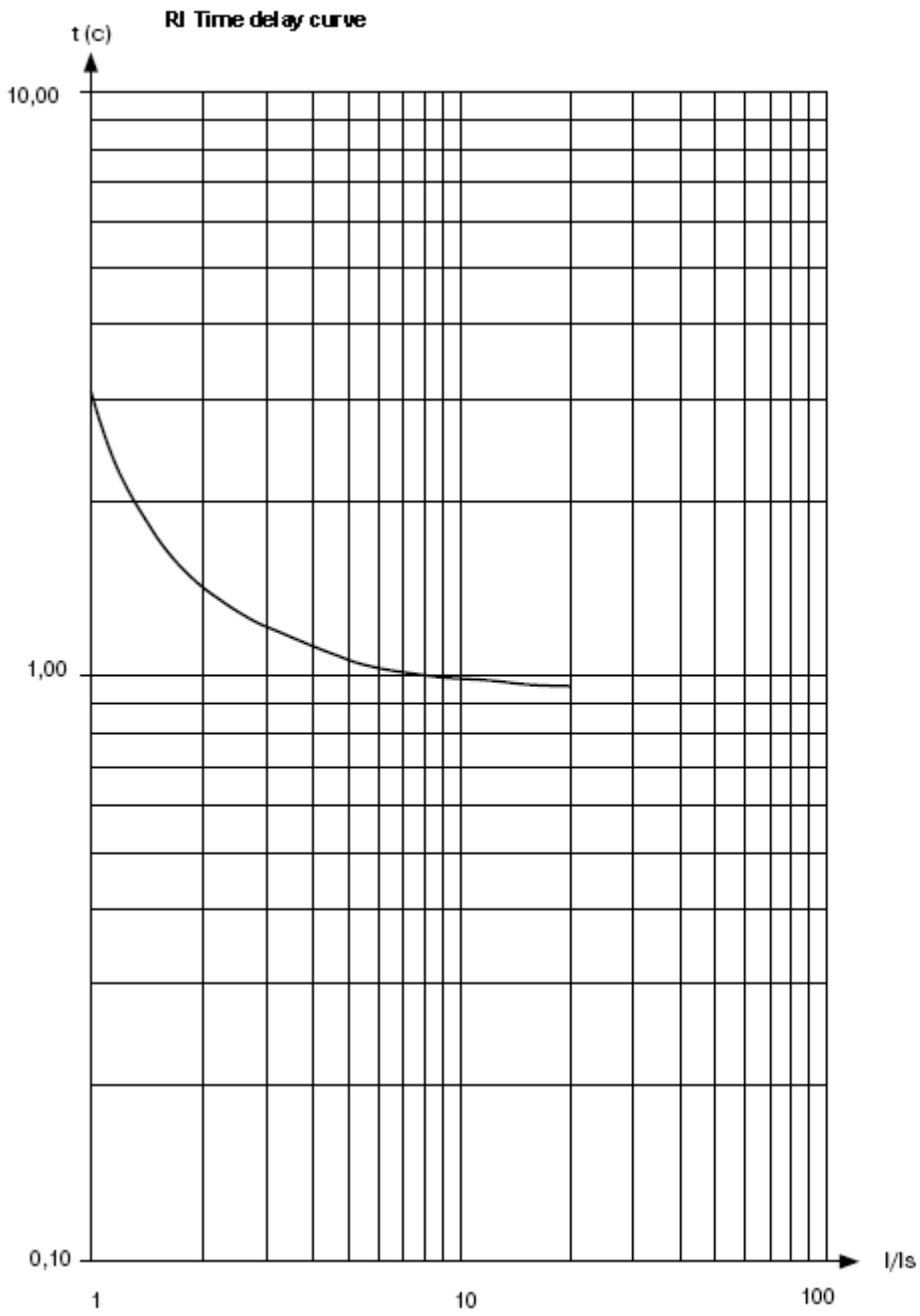

Appendix B UBZ OPERATION FOR MOTOR CONTROL WITH WINDING CHANGEOVER WHEN STAR-TO-DELTA STARTING (mandatory)

- When UBZ is in the star-delta mode it is allowed performing the motor control in the following ways:
- the motor disabling/enabling using the external automatic starter (actuator) at the same time with the de-energizing/energizing the UBZ unit;
 - motor control on the front panel of UBZ;
 - motor control via RS-232/RS-485 interface.

It is strictly forbidden to shutdown the motor by external machine (the starter) without UBZ de-energizing. As an exception, it is allowed after the motor is switched off by external machine (the starter), additionally to turn off the motor on UBZ front panel or via RS-232/RS-485 interface to avoid the direct delta starting

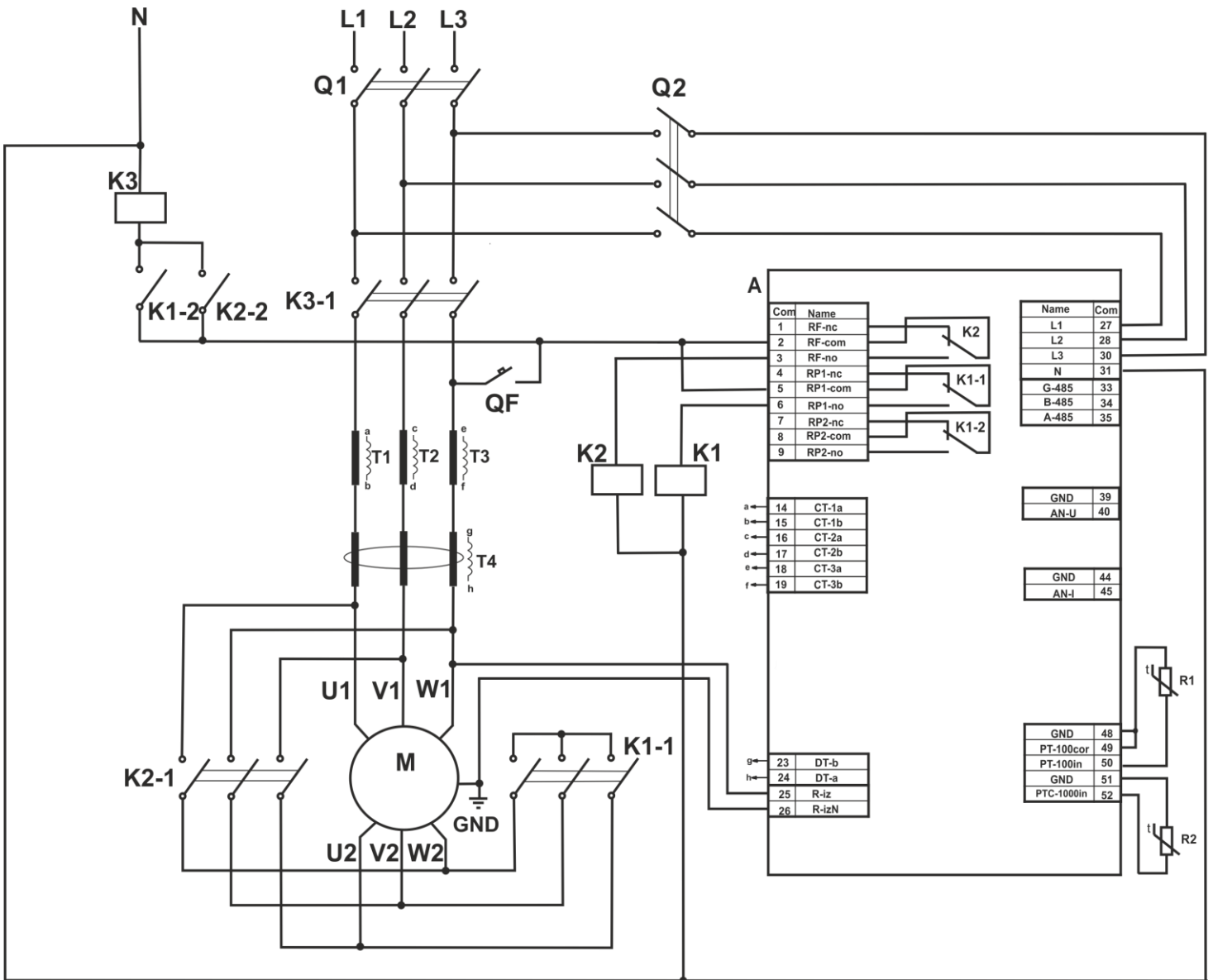

- K1 – Star starter of motor winding enabling;
 K2 - Delta starter of motor winding enabling;
 K3 – Starter of motor enabling;
 Q1, Q2, QF – Circuit breaker.

Fig. B – Diagram for UBZ enabling for the motor operation with star-delta switching over and the motor insulation control