



Product Technical Specification

AirPrime XA1110



SIERRA
WIRELESS®

41111069
Rev 2

Important Notice

Due to the nature of wireless communications, transmission and reception of data can never be guaranteed. Data may be delayed, corrupted (i.e., have errors) or be totally lost. Although significant delays or losses of data are rare when wireless devices such as the Sierra Wireless modem are used in a normal manner with a well-constructed network, the Sierra Wireless modem should not be used in situations where failure to transmit or receive data could result in damage of any kind to the user or any other party, including but not limited to personal injury, death, or loss of property. Sierra Wireless accepts no responsibility for damages of any kind resulting from delays or errors in data transmitted or received using the Sierra Wireless modem, or for failure of the Sierra Wireless modem to transmit or receive such data.

Safety and Hazards

Do not operate the Sierra Wireless modem in areas where blasting is in progress, where explosive atmospheres may be present, near medical equipment, near life support equipment, or any equipment which may be susceptible to any form of radio interference. In such areas, the Sierra Wireless modem **MUST BE POWERED OFF**. The Sierra Wireless modem can transmit signals that could interfere with this equipment.

Do not operate the Sierra Wireless modem in any aircraft, whether the aircraft is on the ground or in flight. In aircraft, the Sierra Wireless modem **MUST BE POWERED OFF**. When operating, the Sierra Wireless modem can transmit signals that could interfere with various onboard systems.

Note: Some airlines may permit the use of cellular phones while the aircraft is on the ground and the door is open. Sierra Wireless modems may be used at this time.

The driver or operator of any vehicle should not operate the Sierra Wireless modem while in control of a vehicle. Doing so will detract from the driver or operator's control and operation of that vehicle. In some states and provinces, operating such communications devices while in control of a vehicle is an offence.

Limitation of Liability

The information in this manual is subject to change without notice and does not represent a commitment on the part of Sierra Wireless. SIERRA WIRELESS AND ITS AFFILIATES SPECIFICALLY DISCLAIM LIABILITY FOR ANY AND ALL DIRECT, INDIRECT, SPECIAL, GENERAL, INCIDENTAL, CONSEQUENTIAL, PUNITIVE OR EXEMPLARY DAMAGES INCLUDING, BUT NOT LIMITED TO, LOSS OF PROFITS OR REVENUE OR ANTICIPATED PROFITS OR REVENUE ARISING OUT OF THE USE OR INABILITY TO USE ANY SIERRA WIRELESS PRODUCT, EVEN IF SIERRA WIRELESS AND/OR ITS AFFILIATES HAS BEEN ADVISED OF THE POSSIBILITY OF SUCH DAMAGES OR THEY ARE FORESEEABLE OR FOR CLAIMS BY ANY THIRD PARTY.

Notwithstanding the foregoing, in no event shall Sierra Wireless and/or its affiliates aggregate liability arising under or in connection with the Sierra Wireless product, regardless of the number of events, occurrences, or claims giving rise to liability, be in excess of the price paid by the purchaser for the Sierra Wireless product.

Patents

This product may contain technology developed by or for Sierra Wireless Inc. This product includes technology licensed from QUALCOMM®. This product is manufactured or sold by Sierra Wireless Inc. or its affiliates under one or more patents licensed from InterDigital Group and MMP Portfolio Licensing.

Copyright

© 2018 Sierra Wireless. All rights reserved.

Trademarks

Sierra Wireless®, AirPrime®, AirLink®, AirVantage® and the Sierra Wireless logo are registered trademarks of Sierra Wireless.

Windows® and Windows Vista® are registered trademarks of Microsoft Corporation.

Macintosh® and Mac OS X® are registered trademarks of Apple Inc., registered in the U.S. and other countries.

QUALCOMM® is a registered trademark of QUALCOMM Incorporated. Used under license.

Other trademarks are the property of their respective owners.

Contact Information

Sales information and technical support, including warranty and returns	Web: sierrawireless.com/company/contact-us/ Global toll-free number: 1-877-687-7795 6:00 am to 6:00 pm PST
Corporate and product information	Web: sierrawireless.com

Revision History

Revision number	Release date	Changes
1	June 23, 2017	Initial revision in SWI template.
2	January 18, 2018	Updates throughout.

>> Contents

Function Description	6
Overview	6
Target Applications	6
Product Highlights and Features	7
System Block Diagram	8
Multi-tone Active Interference Canceller	8
1PPS	8
AGPS for faster TTFF (EPO in flash™)	9
EASY™	9
AlwaysLocate™	9
LOCUS	10
PPS sync NMEA	10
Antenna Advisor	11
Specifications	12
Mechanical Dimensions	12
Recommended PCB Pad Layout	13
Pin Configuration	14
Pin Assignment	14
Description of I/O Pins	15
Specifications	17
Absolute Maximum Ranges	18
Operating Conditions	18
Protocols	19
NMEA Output Sentences	19
GGA—Time, Position and Related Data of Navigation Fix	19
GSA—GNSS DOP and Active Satellites, Including GPS(GPGSA) and GLONASS(GLGSA)	21
GSV— Satellites in View, Including GPS(GPGSV) and GLONASS(GLGSV)	22
RMC—Recommended Minimum Navigation Information	24

VTG—Course and Speed Information Relating to the Ground	25
MTK NMEA Command Protocols	25
Antenna Status Protocol (Antenna Advisor)	26
Reference Design	27
Reference Schematic Design for Using the RTCM/I2C/SPI	27
Schematic Reference Design for the RTCM	27
Schematic Reference Design for Using I2C	28
Schematic Reference Design for the SPI Bus	29
Reference Schematic Design for Using an Active Antenna.	30
Packing and Handling	31
Packaging and Handling (Tape Reel)	31
Storage and Floor Life Guidelines	32
Moisture Color Coded Card & Caution label	32
Conditions for Pre-baking	33
Drying.	34
ESD Handling	35
Reflow Soldering Temperature Profile	36
SMT Reflow Soldering Temperature Profile (For Reference Only)	36
Manual Soldering.	39

>> 1: Function Description

Overview

The XA1110 is a POT (Patch On Top) GNSS module that is capable of tracking GPS and Glonass satellites simultaneously. It comes with an integrated GPS+Glonass¹ patch antenna that is optimized for performance in compact devices. In addition to the integrated antenna, the module also offers an external antenna interface with an automatic antenna switching circuit.

The XA1110 is one of the smallest integrated antenna modules on the market with an ultra-compact size of 12.5 x 12.5 x 6.8 mm in a QFN Package. It supports multiple interfaces such as SPI and I²C that can be used instead of UART.

The module is integrated with SMPS (switching management power system) which allows for the lowest possible power consumption while offering optimum GNSS sensitivity and performance.

The XA1110 is based on latest MT3333 chipset and supports all standard GNSS features including QZSS, SBAS, Anti-Jamming, EASY™, PPS sync NMEA, LOCUS™, GLP™ and AGPS.

Target Applications

- Handheld Devices
- M2M applications
- Asset management
- Surveillance systems
- Wearable products



Figure 1-1: XA1110

1. XA1110 is also capable of supporting GPS+Glonass+Galileo systems. To change the default GNSS system please refer to the "AirPrime XM_XA Series Software User Guide"

Product Highlights and Features

- 33 tracking/ 99 acquisition-channel GPS +GLONASS receiver
- Supports QZSS & SBAS(WAAS, EGNOS, MSAS, GAGAN)¹
- Sensitivity: -165dBm
- Update Rate: up to 10Hz²
- 12 multi-tone active interference canceller
- High accuracy 1-PPS timing (± 20 ns RMS) and the pulse width is 100ms
- AGPS Support for Fast TTFF (EPO in flash™; choose from 7, 14 or 30 days)
- EASY™: Self-Generated Orbit Prediction for instant positioning fix
- AlwaysLocate™ Intelligent Algorithm (Advance Power Periodic Mode) for power saving
- PPS sync NMEA
- LOCUS (Embedded Logger Function)
- Automatic antenna switching function
- Antenna Advisor function
- Support interface types: I2C/ SPI/ UART (configuration)
- Consumption current(@3.3V):
 - For GPS+GLONASS
 - Acquisition: 23mA/ 26mA /29mA (min / typical / max)
 - Full Power Tracking: 24mA / 28mA /32mA (min / typical / max)
- RoHS compliant

1. GAGAN will be supported upon its starting date of service.
2. SBAS can only be enabled when update rate is equal or less than to 5Hz.

System Block Diagram

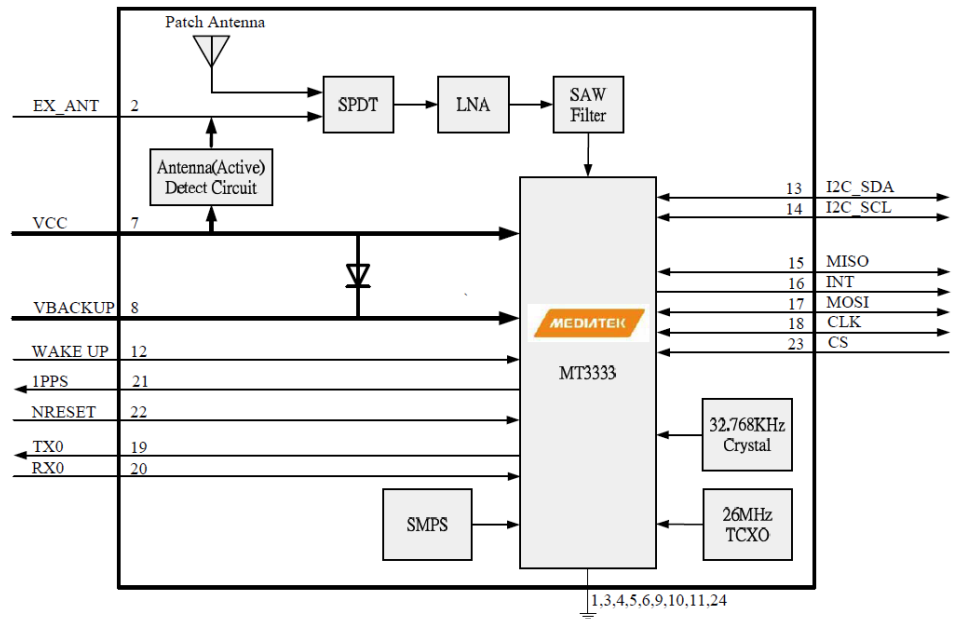

Figure 1-2: System Block Diagram. *I2C Disable in XA1110 by Default, Keep pin floating.

Multi-tone Active Interference Canceller

Many GNSS systems today also integrate various other RF systems such as Wi-Fi, Cellular and Bluetooth. These other radios can often generate RF harmonics which can influence GPS reception and performance.

The embedded Multi-Tone Active Interference Canceller (MTAIC) also known as Anti-Jamming can reject such unwanted RF harmonics from nearby on-board active components. Anti-Jamming can improve the capacity of GPS reception, eliminating the need for additional hardware engineering to compensate for these interferences. This built-in feature can cancel up to 12 independent channels continuous interference waves.

1PPS

The XA1110 generates a-pulse-per-second signal (1 PPS). It is an electrical signal which precisely indicates the start of a second with an accuracy of $\pm 20\text{ns}$ RMS (Root Mean Square). The PPS signal is provided through a designated output pin for external applications. The pulse is limited to being active every second but also allows for programming of the (required) user-defined duration, frequency, and active high/low settings.

AGPS for faster TTFF (EPO in flash™)

The AGPS (EPO in flash™) provides predicated EPO (Extended Prediction Orbit) data to speed up TTFF (Time To First Fix). This feature is useful when satellite signal is weak. AGPS can be downloaded from an FTP server via the Internet or through a wireless network. The GPS engine in the module will use EPO data to assist with position calculation when navigation information from satellites is insufficient. For more details on EPO, please refer to our AGPS application note.

EASY™

EASY™ (Embedded Assist System) is for quick positioning/TTFF when information received from the satellites is insufficient (e.g. in weak signal). When EASY™ is enabled, the GPS engine will automatically calculate and then predict single ephemeris up to three days. The predicted information will be saved into the memory and the GPS engine will then use the saved information for later positioning. Backup power (VBACKUP) is required for EASY™.

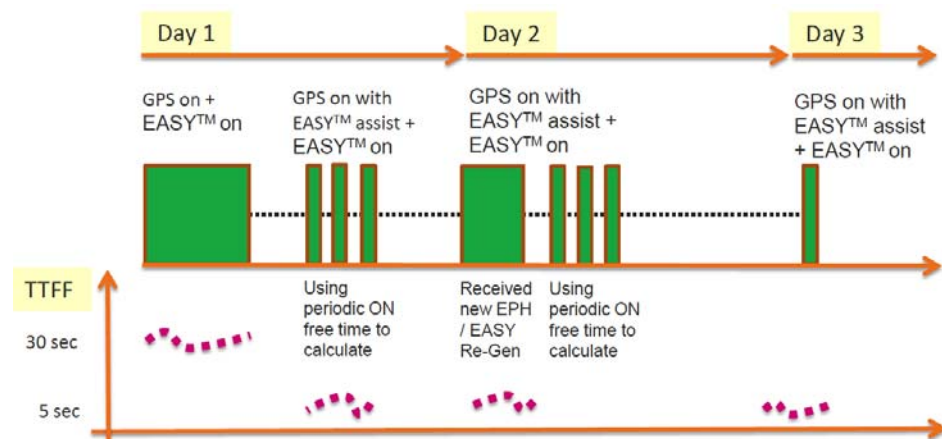

Figure 1-3: Operation of EASY™

Figure 1-3 shows that when the module obtains information from GPS satellites, the GPS engine will start to pre-calculate and predict orbits automatically for the next three days.

AlwaysLocate™

In *AlwaysLocate™* mode, the on/off time can be adjusted adaptively to achieve a balance between positioning accuracy and power consumption depending on various environmental conditions.

Figure 1-4 gives some insight on power saving in different cases when *AlwaysLocate™* mode is enabled.

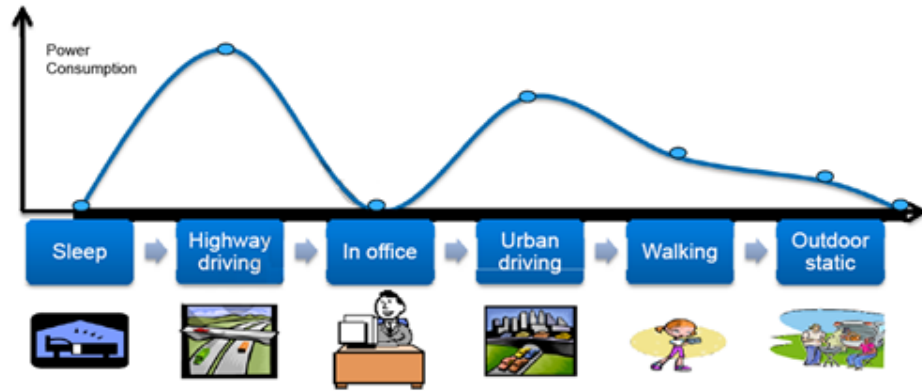

Figure 1-4: AlwaysLocatie

LOCUS

LOCUS (Embedded Logger) function enables the GNSS module to become a logger-capable device. It does not need any host or external flash data format such as UTC, latitude, longitude, valid or checksum for GPS data logging. The maximum log duration is up to two days under AlwaysLocatie™.

PPS sync NMEA

Pulse-Per-Second (PPS) VS. NMEA can be used in the time service. The latency range of the beginning of UART Tx is between 465ms to 485 ms at the MT3333 platform and behind the rising edge of PPS.

The PPS sync NMEA only supports 1Hz NMEA output and a baud rate of 115200 to 14400 bps. For baud rates of 9600 bps and 4800 bps, only the RMC NMEA sentence is supported. If NMEA sentence outputs are supported even at the low baud rate, per-second transmission may exceed the threshold of one second.

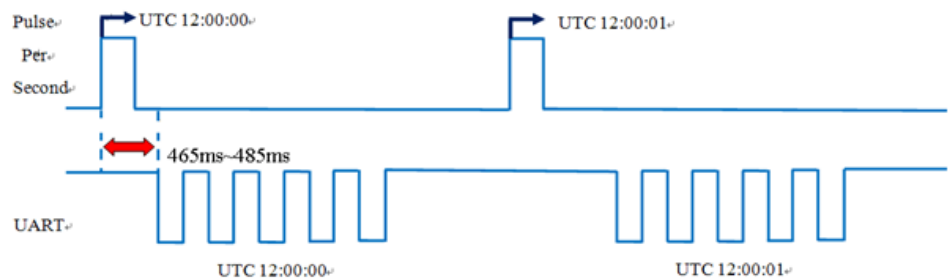

Figure 1-5: PPS sync NMEA

Antenna Advisor

“Antenna Advisor” is a new antenna support feature which is designed to detect and provide the antenna status using software (through a proprietary protocol as described below in [Antenna Status Protocol \(Antenna Advisor\)](#)).

Antenna Advisor can detect and notify about the following changes:

- When using Internal Antenna
- When using External Active Antenna

2: Specifications

Mechanical Dimensions

Dimension: (Unit: mm, Tolerance: +/- 0.2mm)

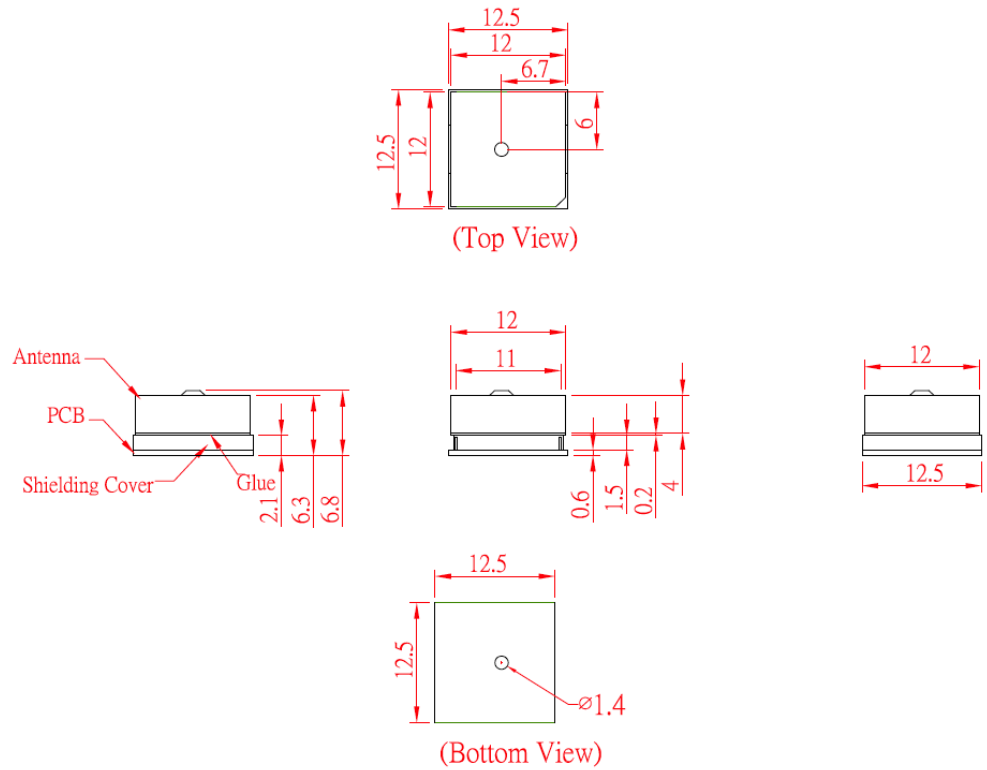

Figure 2-1: Mechanical Dimensions

Recommended PCB Pad Layout

(Unit: mm, Tolerance: 0.1mm)

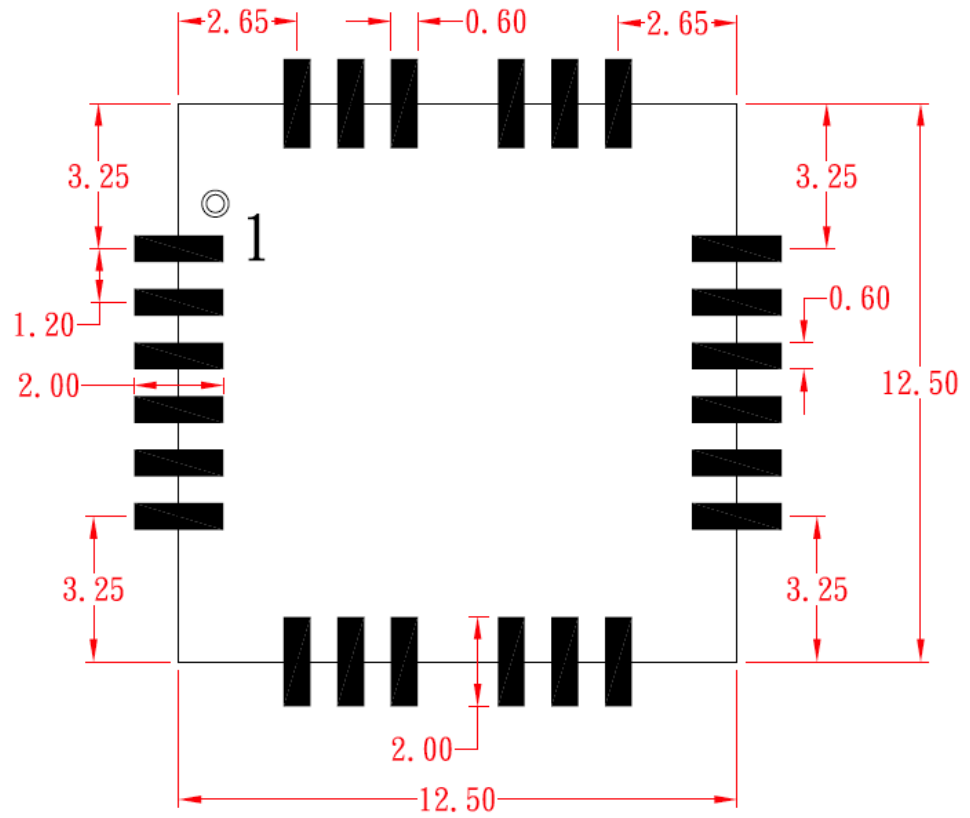

Figure 2-2: PCB Layout

Pin Configuration

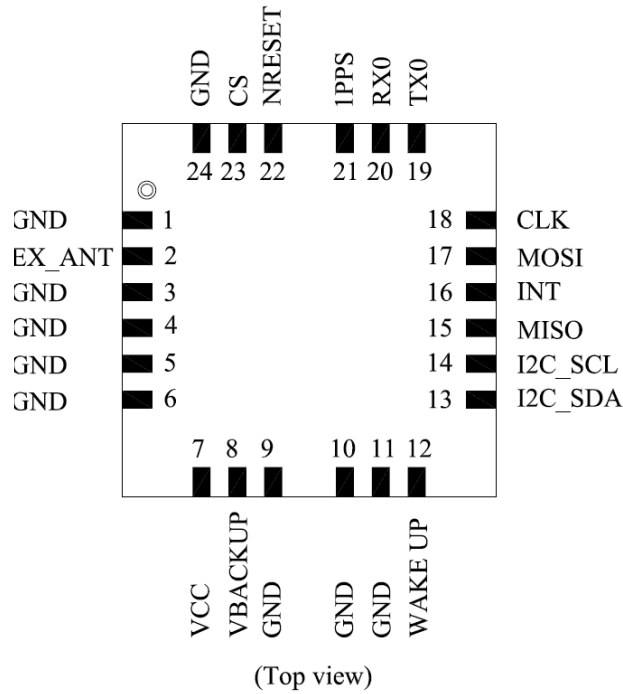

Figure 2-3: Pin Configuration.

Pin Assignment

Table 2-1: Pin Assignment

Pin	Name	I/O	Description and Note
1	GND	P	Ground
2	EXT_ANT	I PO	External active antenna RF input DC power from VCC and provide for external active antenna
3	GND	P	Ground
4	GND	P	Ground
5	GND	P	Ground
6	GND	P	Ground
7	VCC	PI	Main DC power input
8	VBACKUP	PI	Backup power input for RTC & navigation data keep
9	GND	P	Ground
10	GND	P	Ground
11	GND	P	Ground

Table 2-1: Pin Assignment

Pin	Name	I/O	Description and Note
12	WAKE UP	PI	Wake up from power saving, High Active
13	I2C_SDA	I/O	I2C Serial data (in slave mode)
14	I2C_SCL	I	I2C Serial clock (in slave mode)
15	MISO	O	SPI serial data output (in slave mode)
16	INT	O	Interrupt pin for SPI or I2C
17	MOSI	I	SPI serial data input (in slave mode)
18	CLK	I	SPI serial clock
19	TX0	O	Serial Data Output for NMEA output (TTL)
20	RX0	I	Serial Data Input for Firmware update (TTL)
21	1PPS	O	1PPS Time Mark Output 2.8V CMOS Level
22	NRESET	I	Reset Input, Low Active
23	CS	I	SPI serial chip select
24	GND	P	Ground

Description of I/O Pins

- **Pin1:** GND (Ground)
- **Pin2:** EX_ANT
 - When a 4mA or higher current is detected, the detect circuit will acknowledge the external antenna as being present and will use the external antenna for reception. In the event of a short circuit occurring at the external antenna, the module will limit the drawn current to a safe level. DC power from VCC will be provided for the external active antenna (Recommended voltage: 3.3V).
- **Pin3:** GND (Ground)
- **Pin4:** GND (Ground)
- **Pin5:** GND (Ground)
- **Pin6:** GND (Ground)
- **Pin7:** VCC
 - Main DC power supply (3.0V to 4.3V; typical: 3.3V). The ripple must be controlled under 50mVpp.
- **Pin8:** VBACKUP
 - This connects to the backup power of the GNSS module. A power source (such as a battery) connected to this pin will help the GNSS chipset in keeping its internal RTC running when the main power source is turned off. The voltage ranges from 2.0V to 4.3V (typical: 3.0V).
 - If VBACKUP power is not reserved, the GNSS module will perform a lengthy cold start each time it is powered on, as previous satellite information is not retained and needs to be re-transmitted.
 - If not used, keep this pin floating.

- **Pin9:** GND (Ground)
- **Pin10:** GND (Ground)
- **Pin11:** GND (Ground)
- **Pin12:** WAKE UP.
 - Active on High will wake up the module from backup (power-saving) mode.

Table 2-2: WAKE UP

Symbol	Min(V)	Typ(V)	Max(V)
Low	--	0	--
High	1.2	2.8	3.4

The PMTK225 command is recommended for use with the WAKE UP pin for power saving. For more details please refer to our “XM_XA Software User Guide” document.

- **Pin13:** I²C_SDA (I²C; outputs GPS information/RTCM_TX)
- **Pin14:** I²C_SCL (RTCM_RX)
 - This pin can be modified through firmware customization.
 - The *default* of this pin is defined to I²C_SCL. It will receive the clock for I²C application.
 - If the pin is customized to RTCM, it will receive DGPS/RTCM (TTL level).
 - If not used, keep this pin floating.
- **Pin15:** MISO (SPI; outputs GPS information)
- **Pin16:** INT
 - This is the interrupt sync. It is used to determine whether NMEA is stored in SPI/ I²C buffer.
 - If NMEA data is ready and stored in SPI/ I²C buffer, the pin will pull low.
 - After entire NMEA packet of one second is read, the pin will pull high.
- **Pin17:** MOSI (SPI; to receive commands from system)
- **Pin18:** CLK (SPI; to receive clock time from system)
- **Pin19:** TX0 (UART 0 transmitter; outputs GPS information for application)
- **Pin20:** RX0 (UART 0 receiver; to receive commands from system)
- **Pin21:** 1PPS
 - This pin provides one pulse-per-second signal output. If not used, keep this pin floating.
- **Pin22:** NRESET
 - **Active** on Low for the module to reset. If not used, keep this pin floating.

Table 2-3: NRESET

NRESET Level	Min(V)	Typ(V)	Max(V)
Low	0	0	1.5
High	2	2.8	3.3

- **Pin23:** CS (SPI; to select chip for system)
 - Active on Low to enable SPI
- **Pin24:** GND (Ground)

Specifications

Table 2-4: Specification Data

Description	
GNSS Solution	MTK MT3333
Frequency	GPS L1, 1575.42MHz GLONASS L1, 1598.0625~1605.375MHz
Sensitivity (GPS portion)	Acquisition: -148dBm, cold start Reacquisition: -163dBm, Hot start Tracking: -165dBm
SV Number GPS GLONASS	#1~32 #65~96 (see Chapter 3 for details)
TTFF (GPS, No. of SVs>4, C/ N>40dB, PDop<1.5)	Hot start: 1 second typical Warm start: 33 seconds typical Cold start: 35 seconds typical, 60 seconds Max
Position Accuracy	Without aid:3m (50% CEP) DGPS(SBAS(WAAS,EGNOS,MSAS, GAGAN)):2.5m (50% CEP)
Velocity Accuracy	Without aid: 0.1m/s DGPS(SBAS(WAAS,EGNOS,MSAS, GAGAN)):0.05m/s
Timing Accuracy (1PPS Output)	Default: ± 20 ns RMS within 100ms in one pulse (pulse width/duration can be customized)
Altitude	10,000m maximum (Normal mode: car/pedestrian/ aviation) 80,000m maximum (Balloon mode)
Velocity	Maximum 515m/s (1000 knots)
Acceleration	Maximum 4G
Update Rate	1Hz (default), maximum 10Hz
Baud Rate	115200 bps (default)
DGPS	SBAS (default) [WAAS, EGNOS, MSAS, GAGAN]
Power Supply	VCC: 3V to 4.3V; VBACKUP: 2.0V to 4.3V
Current Consumption @ 3.3V,1Hz Update Rate	GPS+GLONASS Acquisition: 23mA/ 26mA /29mA (min / typical / max) Full Power Tracking: 24mA / 28mA / 32mA (min / typical / max) GLP (GNSS Low-power) Tracking: 9mA / 15mA / 31mA (min / typical / max)
Backup Power Consumption@ 3V	17uA (TYP)
Power Saving (Periodic)	Backup mode: 1.2mA (TYP) Standby mode: 1.6mA (TYP)
NRESET Current @ 3.3V	9mA (TYP)
Working Temperature	-40 °C to +85 °C

Table 2-4: Specification Data

Description	
Dimension	12.5x12.5 x 6.8 mm, SMD
Weight	4g

Absolute Maximum Ranges

The maximum power supply voltage is 4.3.

Table 2-5: Maximum Ranges

	Symbol	Min.	Typ.	Max.	Unit
Power Supply Voltage	VCC	3.0	3.3	4.3	V
Backup Battery Voltage	VBACKUP	2.0	3.0	4.3	V

Operating Conditions

Table 2-6: Operating Conditions

	Condition	Min.	Typ.	Max.	Unit
Operation Supply Ripple Voltage	-	-	-	50	mVpp
RX0 TTL H Level	-	2.0	-	3.3	V
RX0 TTL L Level	-	0	-	0.8	V
TX0 TTL H Level	-	2.4	-	2.8	V
TX0 TTL L Level	-	0	-	0.4	V

3: Protocols

NMEA Output Sentences

Table 3-1 lists all NMEA output sentences specifically developed and defined by MTK for MTK's products.

Table 3-1: Position Fix Indicator

Option	Description
GGA	Time, position and fix type data.
GSA	GNSS receiver operating mode, active satellites used in the position solution and DOP values.
GSV	The number of GPS satellites in view, satellite ID numbers, elevation, azimuth, and SNR values.
RMC	Time, date, position, course and speed data. The recommended minimum navigation information.
VTG	Course and speed information relative to the ground.

Table 3-2 lists NMEA output sentences used in GPS system and GLONASS system

Table 3-2: NMEA Output Sentence for GPS and GNSS

System	GGA	GSA	GSV	RMC	VTG
GPS	GPGGA	GPGSA	GPGSV	GPRMC	GPVTG
GNSS (GPS+GLONASS)	GNGGA	GPGSA GLGSA	GPGSV GLGSV ^a	GNRMC	GNVTG

a. In Talker ID, GP is a short term of "GPS"; GL is "GLONASS" and GN is "GPS +GLONASS"

GGA—Time, Position and Related Data of Navigation Fix

Table 3-3 explains the NMEA sentence below:

```
$GNGGA, 064951.000, 2307.1256, N, 12016.4438, E, 1, 8, 0.95, 39.9, M, 17.8, M, *65
```

Table 3-3: GGA Data Format

Name	Example	Units	Description
Message ID	\$GNGGA		GGA protocol header
UTC Time	064951.000		hhmmss.sss
Latitude	2307.1256		ddmm.mmmm

Table 3-3: GGA Data Format

Name	Example	Units	Description
N/S Indicator	N		N North or S South
Longitude	12016.4448		dddmm.mmmm
E/W Indicator	E		E East or W West
Position Fix Indicator	1		See Table 3-4
Satellites Used	8		
HDOP	0.95		Horizontal Dilution of Precision
MSL Altitude	39.9	meters	Antenna Altitude above/below mean-sea-level
Units	M	meters	Units of antenna altitude
Geoidal Separation	17.8	meters	
Units	M	meters	Units of geoids separation
Age of Diff. Corr.		second	Null fields when DGPS is not used
Checksum	*65		
<CR> <LF>			End of message termination

Table 3-4: Position Fix Indicator

Value	Description
0	Fix not available
1	GPS Fix
2	Differential GPS Fix

GSA—GNSS DOP and Active Satellites, Including GPS(GPGSA) and GLONASS(GLGSA)

Table 3-5 explains the example NMEA sentence below:

```
GPS satellite system:
$GPGSA,A,3,29,21,26,15,18,09,06,10,,,,,2.32,0.95,2.11*00

GPS+GLONASS satellite system:
$GPGSA,A,3,08,28,20,04,32,17,11,,,,,1.00,0.63,0.77*1B (GPS
satellite)
$GLGSA,A,3,77,76,86,78,65,88,87,71,72,,,,,1.00,0.63,0.77*17
(GLONASS satellite)
```

Table 3-5: GGA Data Format

Name	Example	Units	Description
Message ID	\$GPGSA, or \$GLGSA		GSA protocol header
Mode 1	A		See Table 3-6
Mode 2	3		See Table 3-7
Satellite Used ^a	8		SV on Channel 1
Satellite Used	28		SV on Channel 2
....
Satellite Used			SV on Channel 12
PDOP	1		Position Dilution of Precision
HDOP	0.63		Horizontal Dilution of Precision
VDOP	0.77		Vertical Dilution of Precision
Checksum	*1B		
<CR> <LF>			End of message termination

a. GPS SV No. #01~#32
GLONASS SV No. #65~#96

Table 3-6: Mode 1

Value	Description
M	Manual—forced to operate in 2D or 3D mode
A	2D Automatic—allowing to switch to 2D/3D mode automatically

Table 3-7: Mode 2

Value	Description
1	Fix not available
2	2D (<4 SVs used)
3	3D (>=4 SVs used)

GSV— Satellites in View, Including GPS(GPGSV) and GLONASS(GLGSV)

Table 3-8 explains the example NMEA sentences below:

```
$GPGSV,4,1,14,28,75,321,44,42,54,137,39,20,53,080,44,17,40,30,44*77
$GPGSV,4,2,14,04,33,253,43,32,28,055,41,08,26,212,40,11,14,055,33*7F
$GPGSV,4,3,14,10,12,198,,07,06,179,38,23,04,125,44,27,02,314,*7E
$GPGSV,4,4,14,193,,,42,01,,,36*45
```

Table 3-8: GPGSV Data Format

Name	Example	Units	Description
Message ID	\$GPGSV		GSV protocol header
Number of Messages	4		(Depending on the number of satellites tracked, multiple messages of GSV data may be required) ^a
Message Number	1		
Satellites in View	14		
Satellite ID	28		Channel 1 (Range 1 to 32)
Elevation	75	degrees	Channel 1 (Maximum 90)
Azimuth	321	degrees	Channel 1 (True, Range 0 to 359)
SNR (C/No)	44	dB-Hz	Range 0 to 99, (null when not tracking)
....
Satellite ID	17		Channel 4 (Range 1 to 32)
Elevation	40	degrees	Channel 4 (Maximum 90)
Azimuth	330	degrees	Channel 4 (True, Range 0 to 359)
SNR (C/No)	44	dB-Hz	Range 0 to 99, (null when not tracking)

Table 3-8: GPGSV Data Format

Name	Example	Units	Description
Checksum	*77		
<CR> <LF>			End of message termination

a. One GSV sentence can only receive up to 4 SVs

Table 3-9 explains the example NMEA sentences below:

\$GLGSV,4,1,15,72,45,084,40,77,39,246,44,87,36,014,44,65,33,157,36*62

\$GLGSV,4,2,15,78,26,306,41,88,23,315,42,76,15,192,38,86,13,067,38*64

\$GLGSV,4,3,15,71,12,035,38*54

Table 3-9: GLGSV Data Format

Name	Example	Units	Description
Message ID	\$GLGSV		GSV protocol header
Number of Messages	4		(Depending on the number of satellites tracked, multiple messages of GSV data may be required) ^a
Message Number	1		
Satellites in View	15		
Satellite ID	72		Channel 1 (Range 1 to 32)
Elevation	45	degrees	Channel 1 (Maximum 90)
Azimuth	84	degrees	Channel 1 (True, Range 0 to 359)
SNR (C/No)	40	dB-Hz	Range 0 to 99, (null when not tracking)
....
Satellite ID	44		Channel 4 (Range 1 to 32)
Elevation	65	degrees	Channel 4 (Maximum 90)
Azimuth	157	degrees	Channel 4 (True, Range 0 to 359)
SNR (C/No)	36	dB-Hz	Range 0 to 99, (null when not tracking)
Checksum	*62		
<CR> <LF>			End of message termination

a. One GSV sentence can only receive up to 4 SVs

RMC—Recommended Minimum Navigation Information

Table 3-10 explains the example NMEA sentence below:

```
$GNRMC,064951.000,A,2307.1256,N,12016.4438,E,0.03,165.48,260406,3.05,W,A*2C
```

Table 3-10: RMC Data Format

Name	Example	Units	Description
Message ID	\$GNRMC		RMC protocol header
UTC Time	064951.000		hhmmss.sss
Status	A		A: data valid V: data not valid
Latitude	2307.1256		ddmm.mmmm
N/S Indicator	N		N: North S: South
Longitude	12016.44		dddmm.mmmm
E/W Indicator	E		E: East W: West
Speed over Ground	0.03	Knots/hr	
Course over Ground	165.48	degrees	TRUE
Date	260406		ddmmyy
Magnetic Variation	3.05, W	degrees	E: East W: West (By Customization)
Mode	A		A: Autonomous mode D: Differential mode E: Estimated mode
Checksum	*2C		
<CR> <LF>			End of message termination
Message ID	\$GNRMC		RMC protocol header

VTG—Course and Speed Information Relating to the Ground

Table 3-11 explains the example NMEA sentence below:

```
$GNVTG,165.48,T,,M,0.03,N,0.06,K,A*37
```

Table 3-11: VTG Data Format

Name	Example	Units	Description
Message ID	\$GNVTG		VTG protocol header
Course	165.48	degrees	Measured heading
Reference	T		TRUE
Course		degrees	Measured heading
Reference	M		Magnetic Variation (By Customization)
Speed	0.03	Knots/hr	Measured horizontal speed
Units	N		Knots
Speed	0.06	km/hr	Measured horizontal speed
Units	K		Kilometers per hour
Mode	A		A: Autonomous mode D: Differential mode E: Estimated mode
Checksum	*37		
<CR> <LF>			End of message termination

MTK NMEA Command Protocols

Packet Type: 103 PMTK_CMD_COLD_START

Packet Meaning: Cold Start --- Discarding the data of Time, Position, Almanacs and Ephemeris at re-start.

Example: \$PMTK103*30<CR><LF>

Note: Please refer to the XM_XA Software User Guide document for more details.

Antenna Status Protocol (Antenna Advisor)

Package Type: Status of Antenna

Table 3-12: Status of Antenna

Name	Example	Units	Description
Message ID	\$PGCMD		Protocol Header
Command ID	203		Function Type

Example:

\$PGCMD , 203<CR><LF>

Used **Patch antenna** status: PGACK,GTOP Antenna **Internal**.

Used **Active antenna** status: PGACK,GTOP Antenna **External**.

4: Reference Design

This section introduces the reference schematic design for best performance. For additional design guidelines please refer to the Hardware Design Guide document for specific model.

Reference Schematic Design for Using the RTCM/I²C/SPI

The XA1110 provides several interfaces to process GNSS NMEA data (by specified firmware):

1. UART0 + RTCM (for DGPS data)
2. UART0 + I²C (for NMEA data)
3. UART0 + SPI (for NMEA data)

Schematic Reference Design for the RTCM

Figure 4-1 provides a schematic reference design for the RTCM:

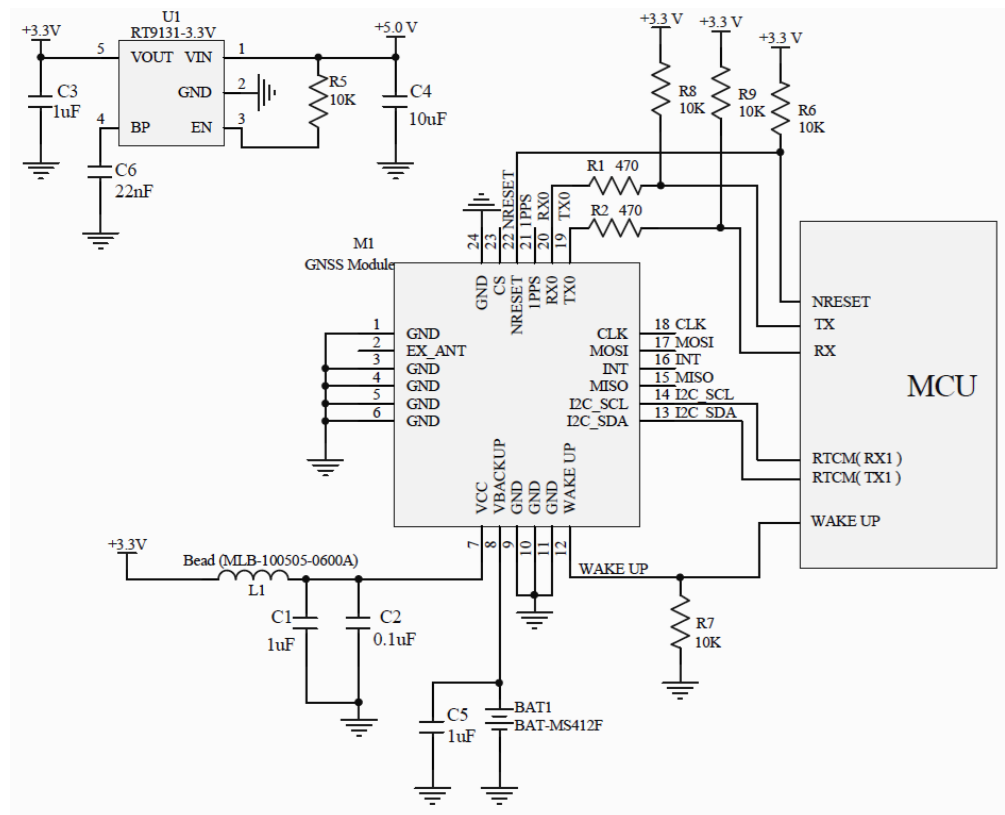

Figure 4-1: UART + RTCM

Notes:

1. Ferrite bead L1 is added for power noise reduction. Use one with an equivalent impedance (600Ω at 100MHz; IDC 200mA).
2. Place C1, C2 and C5 bypass-capacitors as close as possible to the module.
3. Damping resistors R1 and R2 can be modified to manage EMI for system application.

Schematic Reference Design for Using I²C

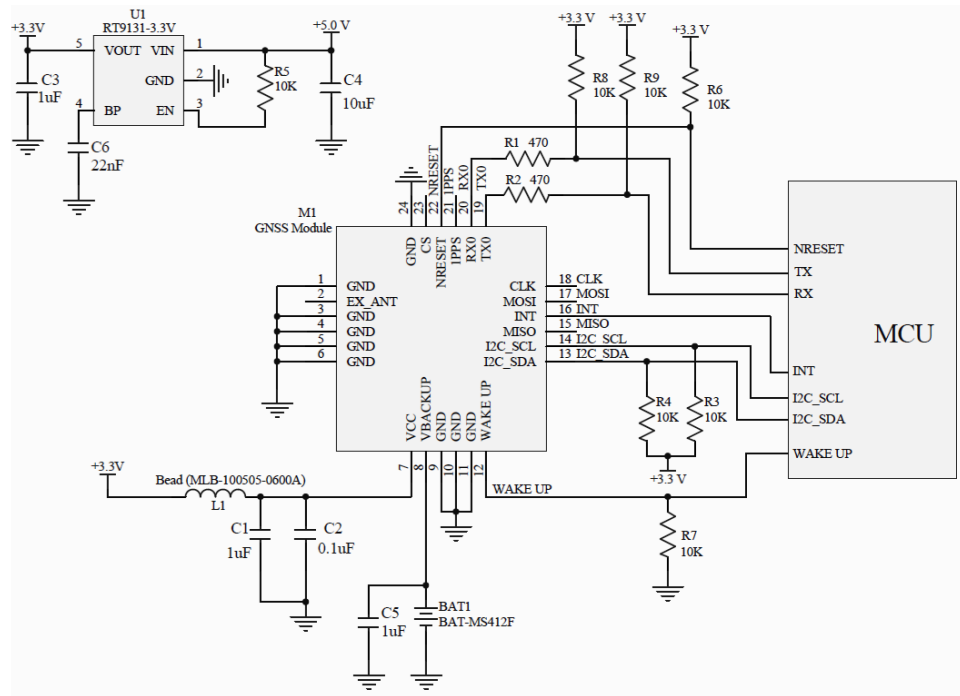

Figure 4-2: UART + I²C

Notes:

1. Ferrite bead L1 is added for power noise reduction. Use one with an equivalent impedance (600Ω at 100MHz; IDC 200mA).
2. Place C1, C2 and C5 bypass-capacitors as close as possible to the module.
3. Damping resistors R1 and R2 can be modified to manage EMI for system application.
4. Pull high resistors, R3 and R4, can be modified based on system application for I²C.
5. The default of Pull-low resistor R7 is set at low level for WAKE UP pin to function.

Schematic Reference Design for the SPI Bus

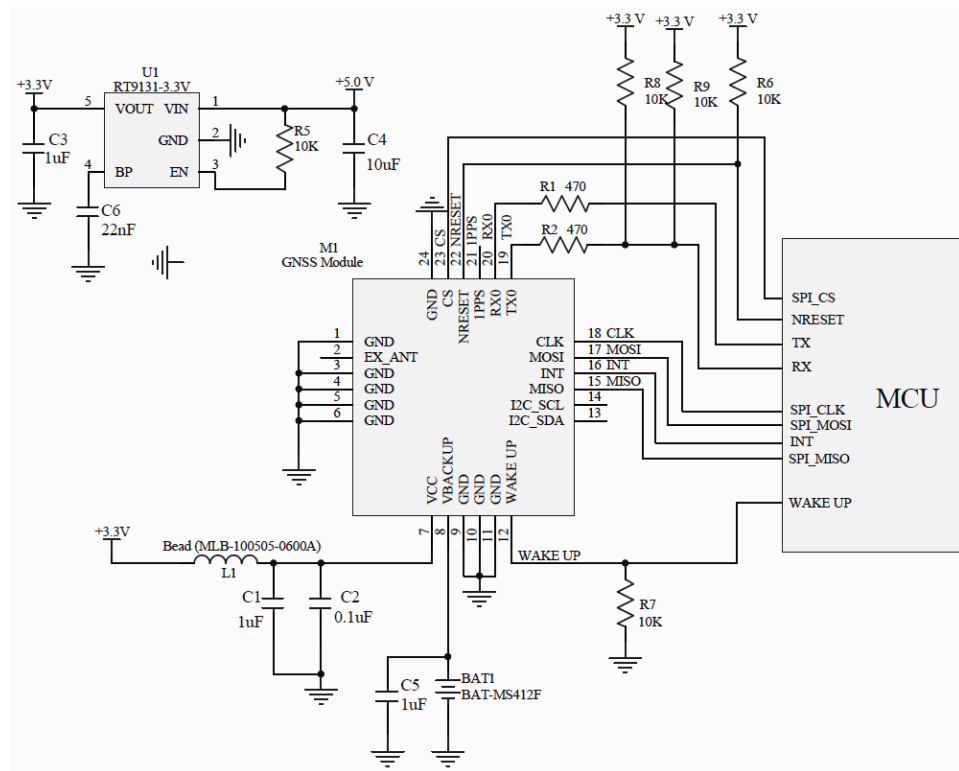

Figure 4-3: UART+SPI Application

Notes:

1. Ferrite bead L1 is added for power noise reduction. Use one with an equivalent impedance (600Ω at 100MHz; IDC 200mA).
2. Place C1, C2 and C5 bypass-capacitors as close as possible to the module.
3. Damping resistors R1 and R2 can be modified to manage EMI for system application.
4. The default of Pull-low resistor R7 is set at low level for WAKE UP pin to function.

Reference Schematic Design for Using an Active Antenna

Connect the external antenna to EX_ANT (Pin2)

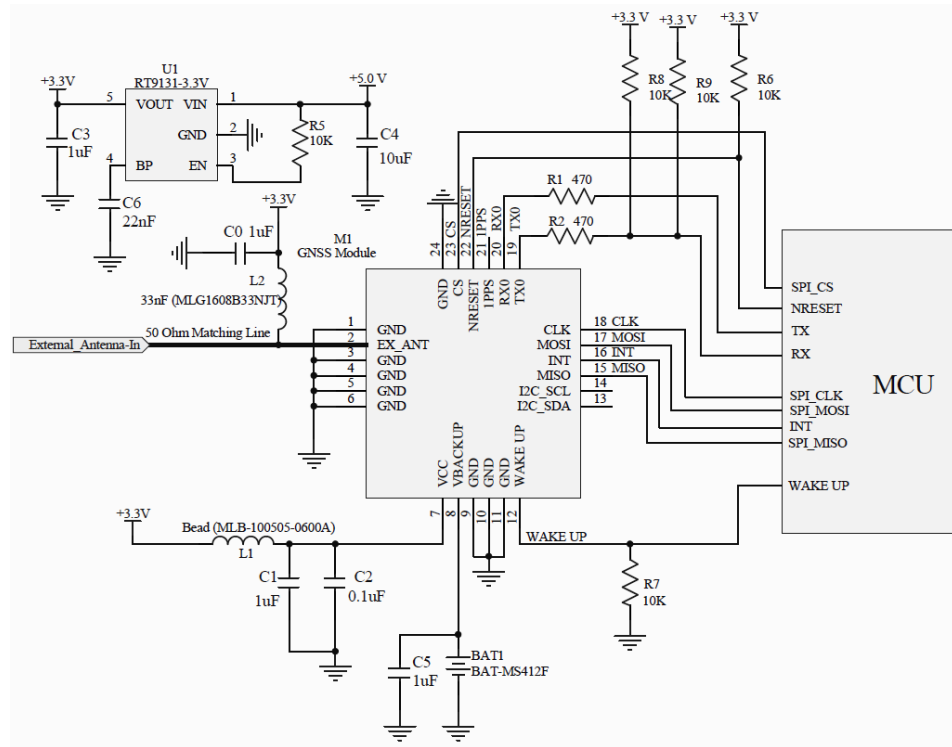

Figure 4-4: Active Antenna Application

Notes:

1. Ferrite bead L1 is added for power noise reduction. Use one with an equivalent impedance (600Ω at 100MHz; IDC 200mA).
2. Place C1, C2 and C5 bypass-capacitors as close as possible to the module.
3. Damping resistors R1 and R2 can be modified to manage EMI for system application.
4. The default of Pull-low resistor R7 is set at a low level for the WAKE UP pin to function.

>> 5: Packing and Handling

The XA1110, like any other SMD device, is sensitive to moisture, electrostatic discharge and temperature. By following the standards of storage and handling outlined in this document for Sierra Wireless' modules, the chances of them being damaged during production set up can be reduced.

This section describes the basics on how Sierra Wireless packages the modules, to ensure that the modules arrive at their destination without any damage or degradation in performance. Cautionary steps prior to the surface mount process are also included in the cautionary notes.

Important: Please read the following sections carefully to avoid possible damage.

Important: GPS/GNSS receiver modules are highly electrostatic-sensitive devices. Lack of ESD protection or improper handling may lead to permanent damage to the modules.

Packaging and Handling (Tape Reel)

400pcs/Reel

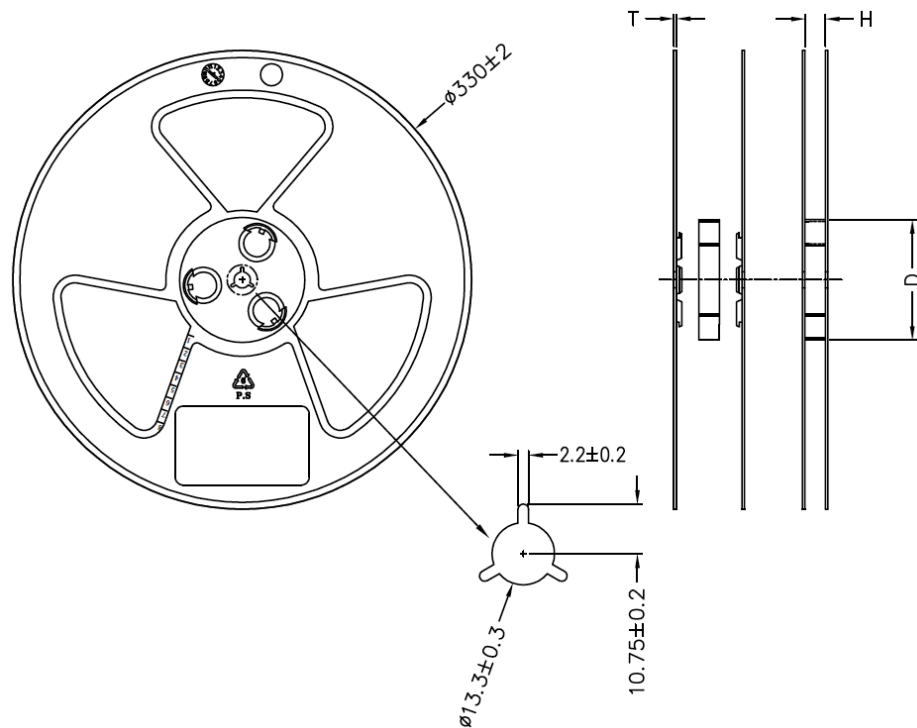

Figure 5-1: Reel Dimensions

Specs:

H: 24.5 ± 1.5 ,
 T: 2.2 ± 0.2 ,
 D: 99 ± 1.5
Note: 13" Reel;
Material: P.S
Unit: (mm)

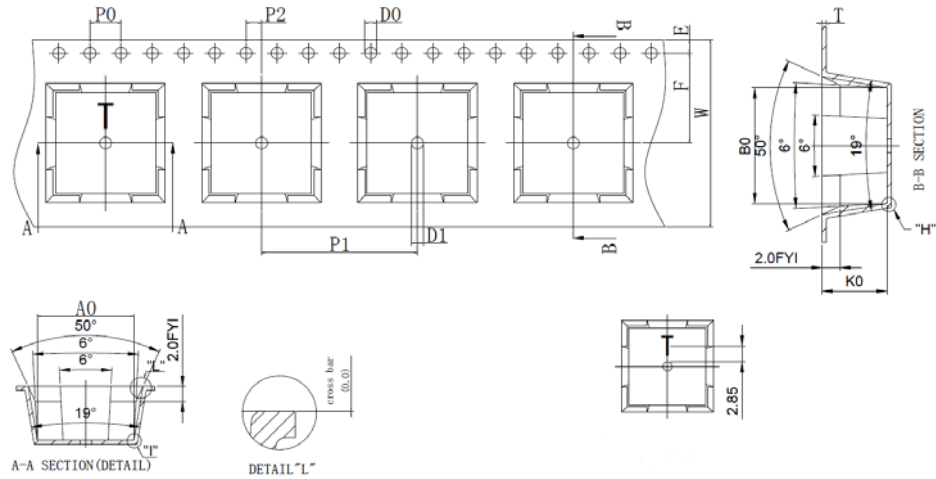

Figure 5-2: Tape Dimensions

Specs:

Ao 12.9 ± 0.10
 Bo $12.9.0 \pm 0.10$
 Ko 7.2 ± 0.10
Unit: (mm)

Storage and Floor Life Guidelines

Moisture Color Coded Card & Caution label

The moisture color-coded card provides an insight to the relative humidity in percentage (RH). When the GNSS modules are taken out, the RH level for the modules is approximately 30% or lower. A caution label is also included with each electrostatic bag.

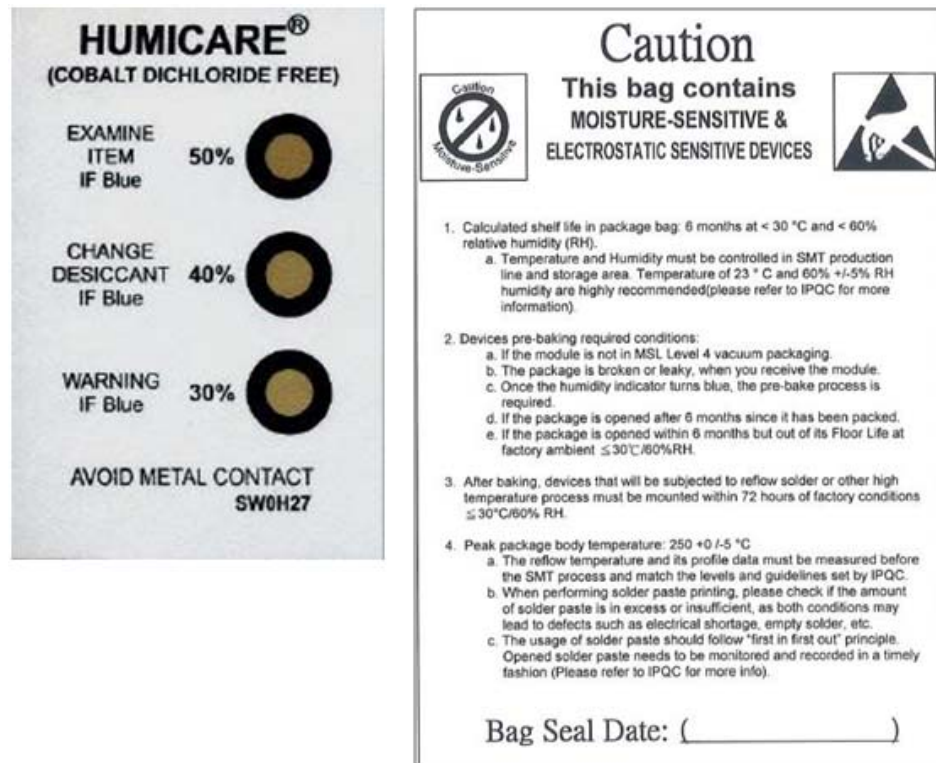

Figure 5-3: Moisture Color Coded Card and Caution Label

Sierra Wireless modules are moisture sensitive. If the package of modules has been stored in a non-condensing storage environment (<30°C; RH 60%) for over six months, the modules will need to go through solder-reflow before SMT.

Important: Prior to solder-reflow, pre-baking will be mandatory if the modules meet any of the conditions listed below in "[Conditions for Pre-baking](#)".

Conditions for Pre-baking

Pre-baking will necessary before the modules go through the solder-reflow process, if any condition listed below is met:

- The package of the module is broken or leaky when you receive it.
- When the humidity indicator turns blue.
- The package is opened six months after the module was packaged.
- The package is opened within six months but its Floor Life at factory ambient is affected (≤30°C; RH 60%).
- When the MSL (Moisture Sensivity Level) of vacuumed module package is higher than Level 4 (level 1~4 are safe; please refer to the [Figure 5-4](#) below):

LEVEL	FLOOR LIFE		SOAK REQUIREMENTS				
			STANDARD		ACCELERATED EQUIVALENT ¹		
					eV 0.40-0.48	eV 0.30-0.39	CONDITION
TIME	CONDITION	TIME (hours)	CONDITION	TIME (hours)	TIME (hours)	CONDITION	
1	Unlimited	≤30 °C/85% RH	168 +5/-0	85 °C/85% RH	NA	NA	NA
2	1 year	≤30 °C/60% RH	168 +5/-0	85 °C/60% RH	NA	NA	NA
2a	4 weeks	≤30 °C/60% RH	696 ² +5/-0	30 °C/60% RH	120 +1/-0	168 +1/-0	60 °C/60% RH
3	168 hours	≤30 °C/60% RH	192 ² +5/-0	30 °C/60% RH	40 +1/-0	52 +1/-0	60 °C/60% RH
4	72 hours	≤30 °C/60% RH	96 ² +2/-0	30 °C/60% RH	20 +0.5/-0	24 +0.5/-0	60 °C/60% RH
5	48 hours	≤30 °C/60% RH	72 ² +2/-0	30 °C/60% RH	15 +0.5/-0	20 +0.5/-0	60 °C/60% RH
5a	24 hours	≤30 °C/60% RH	48 ² +2/-0	30 °C/60% RH	10 +0.5/-0	13 +0.5/-0	60 °C/60% RH
6	Time on Label (TOL)	≤30 °C/60% RH	TOL	30 °C/60% RH	NA	NA	NA

Figure 5-4: Moisture Sensitivity Level Chart

Please note that the modules **must receive solder-reflow 72 hours after pre-baking**. This maximum time is otherwise known as “Floor Life”. If the waiting time exceeds 72 hours, the module may be damaged (cracks / de-lamination, etc.) during the solder-reflow process due to excessive moisture pressure.

Drying

If the modules are exposed to high temperatures in the solder-reflow process, the moisture vapor pressure inside the modules will increase greatly. To prevent delamination, cracking, or “popcorn” effect” to the module, it may need to undergo the pre-baking procedure prior to any high-temperature or solder reflow process. The recommended baking time for the Sierra Wireless GNSS module is: 50°C for four hours, when humidity condition RF is about 30% ~ 50%.

Once baked, the module’s floor life will “reset”, which means the module will remain in normal factory condition for next 72 hours for solder-reflow process.

Note: the “Popcorn Effect” is when the IC/module “pops” because the moisture inside the package expands in the reflow process.

Important: Please limit the number of times that GNSS modules undergo the baking process. Repeated baking processes will affect performance of wetting on the SMD pad contacts. This applies to all SMT devices.

Important: Risk of Oxidation: Baking SMD packages may cause oxidation and/or inter-metallic growth of terminations, which if excessive, can result in problems of solderability during board assembly. The temperature and time for baking SMD packages are therefore limited by solderability considerations. The cumulative bake time at a temperature greater than 90°C and up to 125°C shall not exceed 96 hours. Bake temperatures higher than 125°C are not allowed.

ESD Handling

Warning: *Please follow the precautions addressed below carefully to prevent severe damage to GNSS modules.*

Sierra Wireless modules are sensitive to electrostatic discharges and thus are Electrostatic Sensitive Devices (ESD). Handle the GNSS modules carefully particularly around its patch antenna (if included) and RF_IN pin. Please follow the standard ESD safety practices stated below:

- Unless there is a galvanic coupling between the local GND and the PCB GND, then the first point of contact when handling the PCB shall always be between the local GND and PCB GND.
- Before working with the RF_IN pin, please make sure the GND is connected.
- When working with the RF_IN pin, do not contact any charged capacitors or materials that can easily develop or store charges such as the patch antenna, coax cable, or soldering iron.
- Please do not touch the mounted patch antenna, to prevent electrostatic discharge from the RF input
- When soldering RF_IN pin, please make sure to use an ESD safe soldering iron tip.

6: Reflow Soldering Temperature Profile

The following reflow temperature profile was evaluated by Sierra Wireless and has been proven to be reliable qualitatively. Please contact us beforehand if you plan to solder this component using a deviated temperature profile as it may cause significant damage to our module and your device.

All the information in this datasheet can only be used for a Pb-free manufacturing process.

SMT Reflow Soldering Temperature Profile (For Reference Only)

- Solder paste alloy: SAC305(Sn96.5/Ag3.0/Cu0.5).
- Pre-heat Temp: 150~200°C; Soak time(t_s): 60~120sec.
- Peak temp(T_p) \leq 250°C.
- Time above 220°C(t_p): 40~90sec.
- Optimal cooling rate $<$ 3°C/sec, from peak to 220°C.
- The oxygen concentration $<$ 2000 ppm.

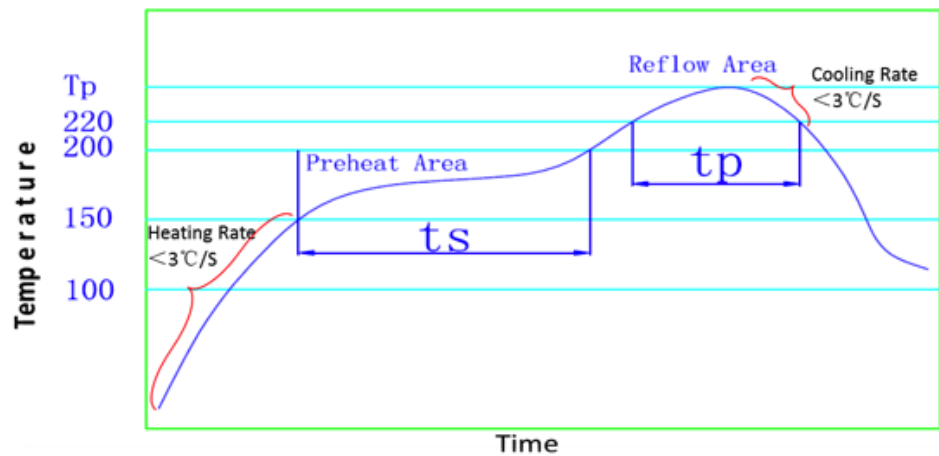

Figure 6-1: SMT Reflow Profile

Table 6-1: Procedures

	Description	Suggestions	Notes
1	Before proceeding with the reflow-soldering process, the GNSS modules might need to be pre-baked. Please refer to Conditions for Pre-baking .	Pre-bake Time: 4 Hours @ 50°C to 60°C.	The maximum tolerated temperature for the tray is 100°C. After pre-baking, make sure the temperature is cooled down to 35°C or below, to prevent tape reel deformation.
2	PCBA (along with the patch antenna) is highly endothermic during the reflow-soldering process. Extra care must be paid to the GNSS module's solder joints for any signs of cold welding or false welding.	The parameters of the reflow temperature must be set accordingly to module's reflow-soldering temperature profile.	Double check to see if the surrounding components around the GNSS module are displaying symptoms of cold weld(ing) or false welding.
3	Special attentions to PCBA board are needed during the reflow-soldering process. Check if the PCBA board is bent or deformed, possibly due to the weight of the module. If so, this will cause concerns at the latter half of the production process.	A loading carrier fixture must be used with PCBA if the reflow soldering process applies rail conveyors for the production.	If PCBA boards are bent or deformed, they may collide into one another during the unloading process.
4	Before the PCBA reflow-soldering process, the operator must visually check to see if there is a positional offset to the module, as it would be difficult to readjust after the module has gone through reflow-soldering process.	The operator must visually check and readjust the position before reflow-soldering process.	If the operator plans to readjust the module position, please do not touch the patch antenna while the module is hot in order to prevent a rotational offset between the patch antenna and module.
5	Before handling the PCBA, it must be cooled to 35°C or below after it has undergone a reflow-soldering process, in order to prevent a positional shift which may occur when the module is still hot.	1. You may use electric fans behind the reflow machine to cool them down. 2. Cooling the PCBA can prevent the module from shifting due to fluid effect.	It is very easy to cause a positional offset to the module and its patch antenna when handling the PCBA under high temperatures.

Table 6-1: Procedures

	Description	Suggestions	Notes
6	<p>1. When separating the PCBA panel into individual pieces using the V-Cut process, special attention is needed to ensure that there are sufficient gap between patch antennas.</p> <p>2. If V-Cut/cutting must be done manually, please make sure the operators are not using excessive force as that may cause a rotational offset to the patch antennas.</p>	<p>1. The blade and the patch antenna must have a distance gap greater than 0.6mm.</p> <p>2. Do not use the patch antenna as a leverage point when separating the panels by hand.</p>	<p>1. A test must first be performed to determine if the V-Cut process is going to be used. Ensure that there is enough space between the blade and the patch antenna so that they do not touch one another.</p> <p>2. An uneven amount of manual force applied to the separation will likely to cause a positional shift in the patch antenna and module.</p>
7	<p>When separating a panel into individual pieces during the latter half of the production process, special attention is needed to ensure the patch antennas do not come in contact with one another in order to prevent chipped corners or positional shifts.</p>	<p>Use a tray to separate the individual pieces.</p>	<p>It is possible to chip a corner and/or cause a shift in position if patch antennas come in contact with each other.</p>

Note: References to patch antenna is referred to GNSS modules with integrated Patch-on-top antennas, and may not be applicable to all GNSS modules.

Other Cautionary Notes on the Reflow-Soldering Process:

1. The module may need pre-baking before going through the SMT solder reflow process. Please refer to [Conditions for Pre-baking](#).
2. The usage of solder paste should follow the “FIFO (First-in-First-out)” principle. Opened solder paste needs to be monitored and recorded in a timely manner (please refer to IPQC standards for related documentation and examples).
3. Temperature and humidity must be controlled within an SMT production line and storage area. A temperature of 23°C, 60±5% RH humidity is recommended (please refer to IPQC standards for related documentation and examples).
4. When performing solder paste printing, please check if the amount of solder paste is excessive or insufficient, as both conditions may lead to defects such as electrical shortage, empty solder, and etc.
5. Make sure the vacuum mouthpiece is able to bear the weight of the GNSS module to prevent positional shift during the loading process.
6. Before the PCBA goes through the reflow-soldering process, the operator must visually check if there is a positional offset to the module.
7. The reflow temperature and its profile data must be measured before the SMT process and match the levels and guidelines set by IPQC.
8. If the SMT protection line is running a double-sided process for PCBA, please process the GNSS module during the second pass only to avoid repeated

reflow exposures of the GNSS module. Please contact Sierra Wireless beforehand if you must process the GNSS module during the first pass of a double-side process.

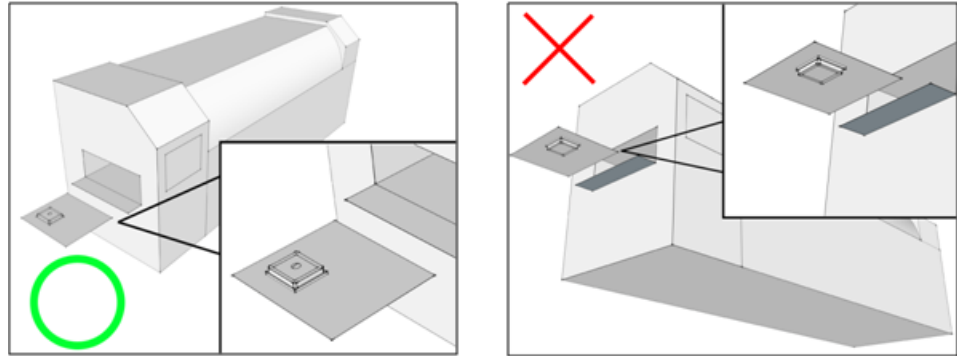

Figure 6-2: Place the GNSS module top side up when running the reflow-solder process. Do not invert.

Manual Soldering

Soldering iron:

Heat temperature: under 380°C | Time: under three seconds.

Notes:

1. To prevent further oxidation, do not touch the soldering pads on the surface of the PCB board directly.
2. The solder paste must be defrosted to room temperature before use so it can return to its optimal working temperature. The time required for this procedure is unique and dependent on the properties of the solder paste used.
3. The steel plate must be properly assessed before and after use, so its measurement stays strictly within the specification set by the SOP.
4. Be cautious to the spacing between soldering joints, as excessive soldering may cause electrical shortages.
5. To avoid possible siphon effects on neighboring components which may lead to electrical shortage, do not use an excessive amount of flux.
6. Do not use the heat gun for long periods of time when removing the shielding or inner components of the GNSS module, as it is very likely to cause a shift to the inner components and will lead to electrical shortages.