

Pushbutton On/Off Controller with μ P Interrupt

FEATURES

- Adjustable Power On/Off Timers
- Low Supply Current: 6 μ A
- Wide Operating Voltage Range: 2.7V to 26.4V
- Low Leakage EN Output (LTC2954-1) Allows DC/DC Converter Control
- High Voltage $\overline{\text{EN}}$ Output (LTC2954-2) Allows Circuit Breaker Control
- Simple Interface Allows Graceful μ P Shutdown
- High Input Voltage $\overline{\text{PB}}$ Pin with Internal Pull-Up Resistor
- $\pm 10\text{kV}$ ESD HBM on $\overline{\text{PB}}$ Input
- Accurate 0.6V Threshold on $\overline{\text{KILL}}$ Comparator Input
- 8-Pin 3mm \times 2mm DFN and ThinSOT™ Packages

APPLICATIONS

- Pushbutton PowerPath™ Control
- Portable Instrumentation Meters
- Blade Servers
- Portable Customer Service PDA
- Desktop and Notebook Computers

DESCRIPTION

The LTC®2954 is a pushbutton on/off controller that manages system power via a pushbutton interface. An enable output toggles system power while an interrupt output provides debounced pushbutton status. The interrupt output can be used in menu driven applications to request a system power-down. A power kill input allows a microprocessor or system to reset the enable output, effectively powering down the system. Independently adjustable on and off timers allow dependable pushbutton control of the enable output and resistance to accidental toggling of system power.

The LTC2954 operates over a wide 2.7V to 26.4V input voltage range to accommodate a wide variety of input power supplies. Very low quiescent current (6 μ A typical) makes the LTC2954 ideally suited for battery powered applications. Two versions of the part are available to accommodate either positive or negative enable polarities.

LT, LT, LTC, LTM, Linear Technology and the Linear logo are registered trademarks and PowerPath and ThinSOT are trademarks of Linear Technology Corporation. All other trademarks are the property of their respective owners.

TYPICAL APPLICATION

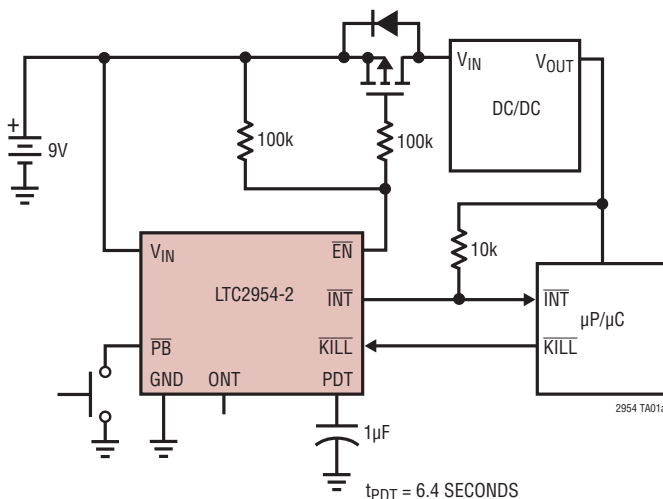

Pushbutton On/Off with Interrupt

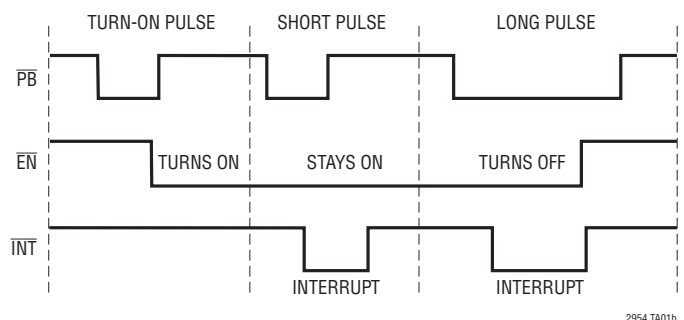

LTC2954

ABSOLUTE MAXIMUM RATINGS (Note 1)

Supply Voltage (V_{IN})	-0.3V to 33V	Operating Temperature Range	
Input Voltages		LTC2954C-1	0°C to 70°C
\overline{PB}	-6V to 33V	LTC2954C-2	0°C to 70°C
ONT	-0.3V to 2.7V	LTC2954I-1	-40°C to 85°C
PDT	-0.3V to 2.7V	LTC2954I-2	-40°C to 85°C
\overline{KILL}	-0.3V to 7V	Storage Temperature Range	
Output Voltages		DFN Package	-65°C to 125°C
\overline{INT}	-0.3V to 10V	TSOT-23	-65°C to 150°C
EN/ \overline{EN}	-0.3V to 33V	Lead Temperature (Soldering, 10 sec)	300°C

PIN CONFIGURATION

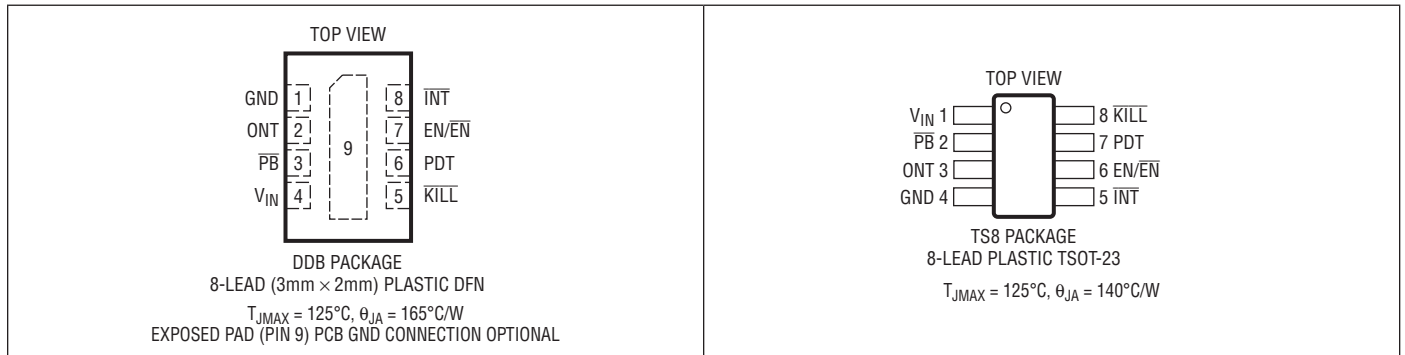

ORDER INFORMATION

LEAD FREE FINISH	TAPE AND REEL	PART MARKING*	PACKAGE DESCRIPTION	TEMPERATURE RANGE
LTC2954CDDB-1#PBF	LTC2954CDDB-1#TRPBF	LCJG	8-Lead (3mm × 2mm) Plastic DFN	0°C to 70°C
LTC2954CDDB-2#PBF	LTC2954CDDB-2#TRPBF	LCNJ	8-Lead (3mm × 2mm) Plastic DFN	0°C to 70°C
LTC2954IDDB-1#PBF	LTC2954IDDB-1#TRPBF	LCJG	8-Lead (3mm × 2mm) Plastic DFN	-40°C to 85°C
LTC2954IDDB-2#PBF	LTC2954IDDB-2#TRPBF	LCNJ	8-Lead (3mm × 2mm) Plastic DFN	-40°C to 85°C
LTC2954CTS8-1#PBF	LTC2954CTS8-1#TRPBF	LTCJH	8-Lead Plastic TSOT-23	0°C to 70°C
LTC2954CTS8-2#PBF	LTC2954CTS8-2#TRPBF	LTCNK	8-Lead Plastic TSOT-23	0°C to 70°C
LTC2954ITS8-1#PBF	LTC2954ITS8-1#TRPBF	LTCJH	8-Lead Plastic TSOT-23	-40°C to 85°C
LTC2954ITS8-2#PBF	LTC2954ITS8-2#TRPBF	LTCNK	8-Lead Plastic TSOT-23	-40°C to 85°C
LEAD BASED FINISH	TAPE AND REEL	PART MARKING*	PACKAGE DESCRIPTION	TEMPERATURE RANGE
LTC2954CDDB-1	LTC2954CDDB-1#TR	LCJG	8-Lead (3mm × 2mm) Plastic DFN	0°C to 70°C
LTC2954CDDB-2	LTC2954CDDB-2#TR	LCNJ	8-Lead (3mm × 2mm) Plastic DFN	0°C to 70°C
LTC2954IDDB-1	LTC2954IDDB-1#TR	LCJG	8-Lead (3mm × 2mm) Plastic DFN	-40°C to 85°C
LTC2954IDDB-2	LTC2954IDDB-2#TR	LCNJ	8-Lead (3mm × 2mm) Plastic DFN	-40°C to 85°C
LTC2954CTS8-1	LTC2954CTS8-1#TR	LTCJH	8-Lead Plastic TSOT-23	0°C to 70°C
LTC2954CTS8-2	LTC2954CTS8-2#TR	LTCNK	8-Lead Plastic TSOT-23	0°C to 70°C
LTC2954ITS8-1	LTC2954ITS8-1#TR	LTCJH	8-Lead Plastic TSOT-23	-40°C to 85°C
LTC2954ITS8-2	LTC2954ITS8-2#TR	LTCNK	8-Lead Plastic TSOT-23	-40°C to 85°C

Consult LTC Marketing for parts specified with wider operating temperature ranges. *The temperature grade is identified by a label on the shipping container.

For more information on lead free part marking, go to: <http://www.linear.com/leadfree/>

For more information on tape and reel specifications, go to: <http://www.linear.com/tapeandree/>

2954fb

ELECTRICAL CHARACTERISTICS

The ● denotes the specifications which apply over the full operating temperature range, otherwise specifications are at $T_A = 25^\circ\text{C}$. $V_{IN} = 2.7\text{V}$ to 26.4V , unless otherwise noted. (Note 2)

SYMBOL	PARAMETER	CONDITIONS	MIN	TYP	MAX	UNITS
V_{IN}	Supply Voltage Range	Steady State Operation	● 2.7		26.4	V
I_{IN}	V_{IN} Supply Current	System Power-On, $V_{IN} = 2.7\text{V}$ to 24V	●	6	12	μA
V_{UVL}	V_{IN} Undervoltage Lockout	V_{IN} Falling	● 2.2	2.3	2.5	V
$V_{UVL(HYST)}$	V_{IN} Undervoltage Lockout Hysteresis		50	400	700	mV
Pushbutton, Enable ($\overline{\text{PB}}$, $\text{EN}/\overline{\text{EN}}$)						
$V_{\overline{\text{PB}}}(\text{MIN, MAX})$	$\overline{\text{PB}}$ Voltage Range	Single-Ended	● -1		26.4	V
$I_{\overline{\text{PB}}}$	$\overline{\text{PB}}$ Input Current	$2.5\text{V} < V_{\overline{\text{PB}}} < 26.4\text{V}$ $V_{\overline{\text{PB}}} = 1\text{V}$ $V_{\overline{\text{PB}}} = 0.6\text{V}$	● ● ●	-1 -6 -3	± 1 -12 -15	μA μA μA
$V_{\overline{\text{PB}}}(\text{VTH})$	$\overline{\text{PB}}$ Input Threshold	$\overline{\text{PB}}$ Falling	● 0.6	0.8	1	V
$V_{\overline{\text{PB}}}(\text{VOC})$	$\overline{\text{PB}}$ Open Circuit Voltage	$I_{\overline{\text{PB}}} = -1\mu\text{A}$	1	1.6	2	V
$t_{\text{EN, LOCKOUT}}$	$\text{EN}/\overline{\text{EN}}$ Lockout Time (Note 5)	Enable Released \rightarrow Enable Asserted	● 200	256	325	ms
$I_{\text{EN}(LKG)}$	$\text{EN}/\overline{\text{EN}}$ Leakage Current	$V_{\text{EN}/\overline{\text{EN}}} = 1\text{V}$, Sink Current Off $V_{\text{EN}/\overline{\text{EN}}} = 26.4\text{V}$, Sink Current Off	● ●		± 0.1 ± 1	μA μA
$V_{\text{EN}(VOL)}$	$\text{EN}/\overline{\text{EN}}$ Voltage Output Low	$I_{\text{EN}/\overline{\text{EN}}} = 500\mu\text{A}$	●	0.11	0.4	V
Power-On Timing Pin (ONT)						
$I_{\text{ONT}(PU)}$	ONT Pull-Up Current	$V_{\text{ONT}} = 0\text{V}$	● -2.4	-3	-3.6	μA
$I_{\text{ONT}(PD)}$	ONT Pull-Down Current	$V_{\text{ONT}} = 1.3\text{V}$	● 2.4	3	3.6	μA
$t_{\text{DB, ON}}$	Internal Turn-On Debounce Time	ONT Pin Float, $\overline{\text{PB}}$ Falling \rightarrow Enable Asserted	● 26	32	41	ms
t_{ONT}	Additional Adjustable Turn-On Time	$C_{\text{ONT}} = 1500\text{pF}$	● 9	11.5	13.5	ms
Power-Down Timing Pin (PDT)						
$I_{\text{PDT}(PU)}$	PDT Pull-Up Current	$V_{\text{PDT}} = 0\text{V}$	● -2.4	-3	-3.6	μA
$I_{\text{PDT}(PD)}$	PDT Pull-Down Current	$V_{\text{PDT}} = 1.3\text{V}$	● 2.4	3	3.6	μA
$t_{\text{DB, OFF}}$	Turn-Off Interrupt Debounce Time	$\overline{\text{PB}}$ Falling \rightarrow $\overline{\text{INT}}$ Falling	● 26	32	41	ms
$t_{\text{PD, MIN}}$	Internal $\overline{\text{PB}}$ Power-Down Debounce Time (Note 4)	PDT Pin Float, $\overline{\text{PB}}$ Falling \rightarrow Enable Released	● 52	64	82	ms
t_{PDT}	Additional Adjustable $\overline{\text{PB}}$ Power-Down Debounce Time	$C_{\text{PDT}} = 1500\text{pF}$	● 9	11.5	13.5	ms
$t_{\overline{\text{INT}}, \text{MIN}}$	Minimum $\overline{\text{INT}}$ Pulse Width	$\overline{\text{INT}}$ Asserted \rightarrow $\overline{\text{INT}}$ Released	● 26	32	41	ms
$t_{\overline{\text{INT}}, \text{MAX}}$	Maximum $\overline{\text{INT}}$ Pulse Width	$C_{\text{PDT}} = 1500\text{pF}$, $\overline{\text{INT}}$ Asserted \rightarrow $\overline{\text{INT}}$ Released	● 35	43.5	54.5	ms
μP Handshake Pins ($\overline{\text{INT}}$, $\overline{\text{KILL}}$)						
$I_{\overline{\text{INT}}(LKG)}$	$\overline{\text{INT}}$ Leakage Current	$V_{\overline{\text{INT}}} = 3\text{V}$	●		± 1	μA
$V_{\overline{\text{INT}}(VOL)}$	$\overline{\text{INT}}$ Output Voltage Low	$I_{\overline{\text{INT}}} = 3\text{mA}$	●	0.11	0.4	V
$V_{\overline{\text{KILL}}(TH)}$	$\overline{\text{KILL}}$ Input Threshold Voltage	$\overline{\text{KILL}}$ Falling	● 0.57	0.6	0.63	V
$V_{\overline{\text{KILL}}(HYST)}$	$\overline{\text{KILL}}$ Input Threshold Hysteresis		● 10	30	50	mV
$I_{\overline{\text{KILL}}(LKG)}$	$\overline{\text{KILL}}$ Leakage Current	$V_{\overline{\text{KILL}}} = 0.6\text{V}$	●		± 0.1	μA
$t_{\overline{\text{KILL}}(PW)}$	$\overline{\text{KILL}}$ Minimum Pulse Width		● 30			μs
$t_{\overline{\text{KILL}}(PD)}$	$\overline{\text{KILL}}$ Propagation Delay	$\overline{\text{KILL}}$ Falling \rightarrow Enable Released	●		30	μs
$t_{\overline{\text{KILL}}, \text{ON BLANK}}$	$\overline{\text{KILL}}$ Turn-On Blanking (Note 3)	$\overline{\text{KILL}} = \text{Low}$, Enable Asserted \rightarrow Enable Released	● 400	512	650	ms

ELECTRICAL CHARACTERISTICS

Note 1: Stresses beyond those listed under Absolute Maximum Ratings may cause permanent damage to the device. Exposure to any Absolute Maximum Rating condition for extended periods may affect device reliability and lifetime.

Note 2: All currents into pins are positive; all voltages are referenced to GND unless otherwise noted.

Note 3: The $\overline{\text{KILL}}$ turn-on blanking timer period is the waiting period immediately after the enable output is asserted. This blanking time allows sufficient time for the DC/DC converter and the μP to perform power-up tasks. The $\overline{\text{KILL}}$ and $\overline{\text{PB}}$ inputs are ignored during this period. If $\overline{\text{KILL}}$ remains low at the end of this time period, the enable output is released,

thus turning off system power. This time delay does not include $t_{\text{DB,ON}}$ or t_{ONT} .

Note 4: To manually force an immediate release of the $\overline{\text{EN}}/\overline{\text{EN}}$ pin, the pushbutton input must be held low for at least $t_{\text{PD,MIN}}$ (internal default power-down timer) + t_{PDT} (adjustable by placing external capacitor at PDT pin).

Note 5: The enable lockout time is designed to allow an application to properly power-down such that the next power-up sequence starts from a consistent powered-down configuration. $\overline{\text{PB}}$ is ignored during this lockout time. This time delay does not include $t_{\text{DB,ON}}$ or t_{ONT} .

TYPICAL PERFORMANCE CHARACTERISTICS

Supply Current vs Temperature

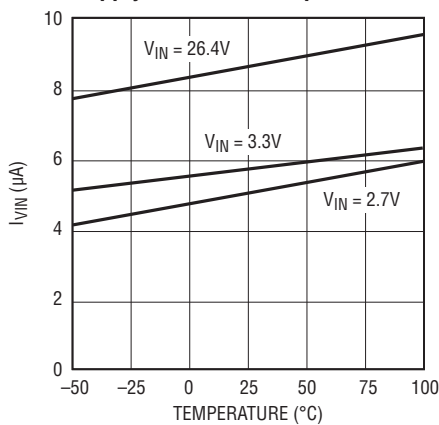

Supply Current vs Supply Voltage

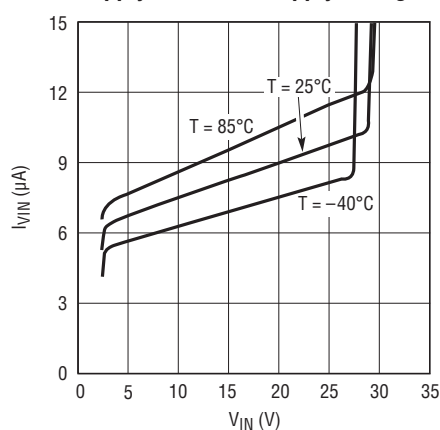

Internal Default Turn-On Debounce Time ($t_{\text{DB,ON}}$) vs V_{IN}

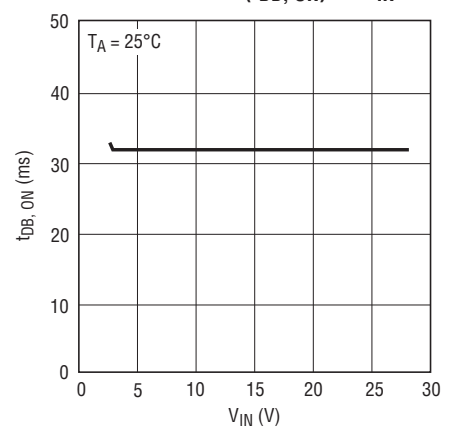

Turn-On Debounce Time ($t_{\text{DB,ON}} + t_{\text{ONT}}$) vs t_{ONT} External Capacitance

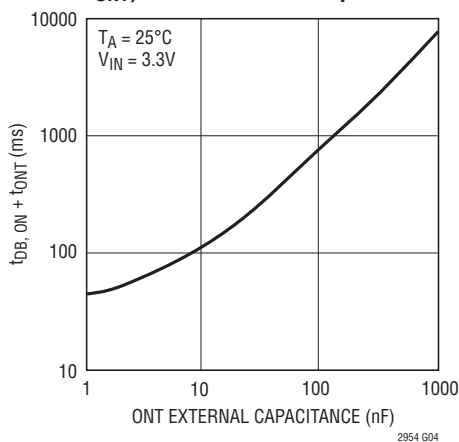

ONT Pull-Up Current vs Temperature

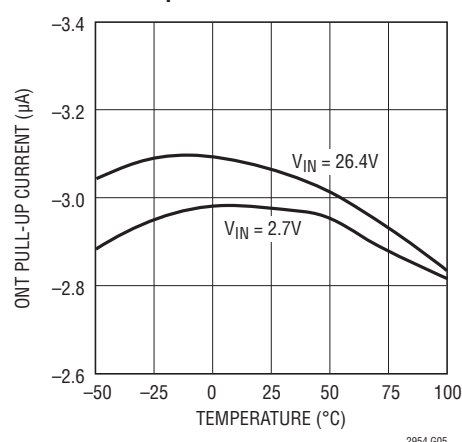

Turn-Off Debounce Time ($t_{\text{DB,OFF}}$) vs V_{IN}

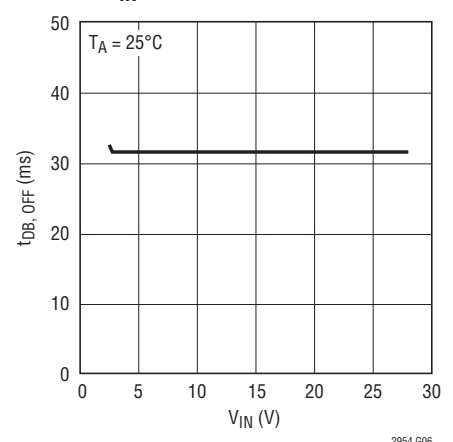

TYPICAL PERFORMANCE CHARACTERISTICS

Internal Default $\overline{\text{PB}}$ Power-Down Debounce Time ($t_{\text{PD,MIN}}$) vs V_{IN}

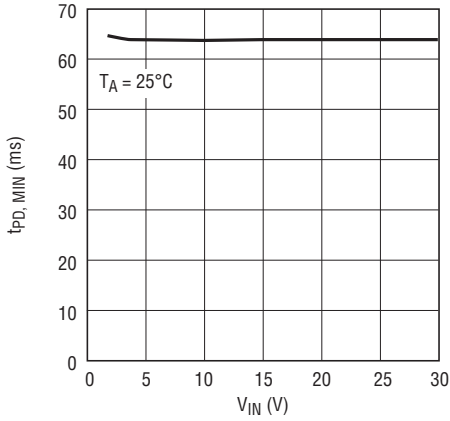

2954 G07

$\overline{\text{PB}}$ Power-Down Debounce Time ($t_{\text{PD,MIN}} + t_{\text{PDT}}$) vs PDT External Capacitance

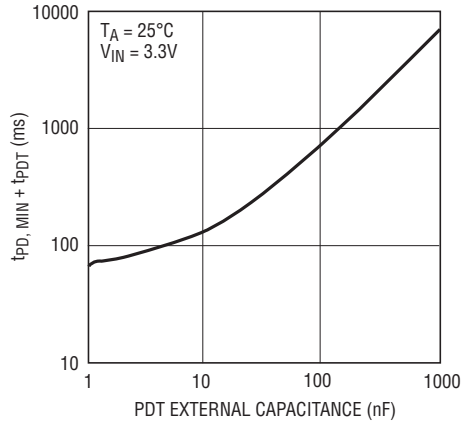

2954 G08

PDT Pull-Up Current vs Temperature

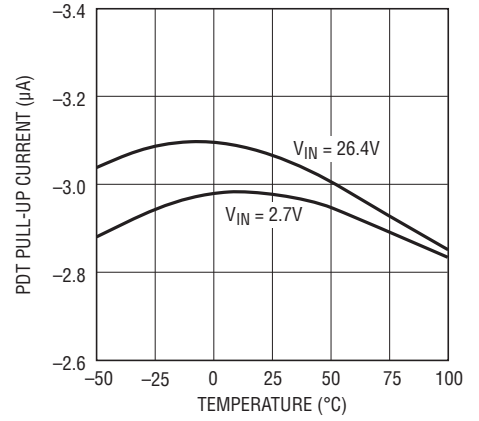

2954 G09

$\overline{\text{PB}}$ Current vs $\overline{\text{PB}}$ Voltage

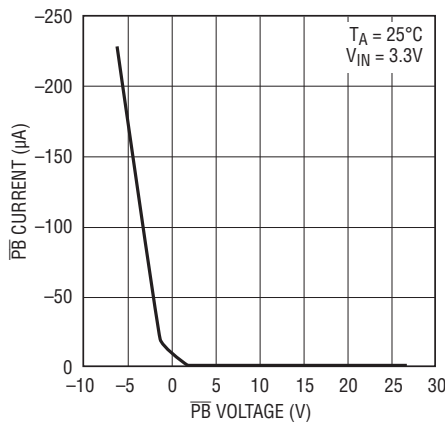

2954 G10

$\overline{\text{PB}}$ Voltage vs External $\overline{\text{PB}}$ Resistance to Ground

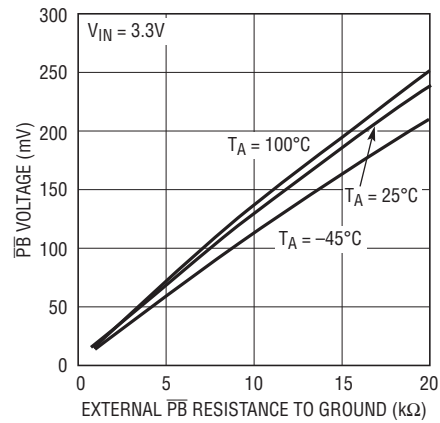

2954 G11

$\text{EN}/\overline{\text{EN}}$ V_{OL} vs Current Load

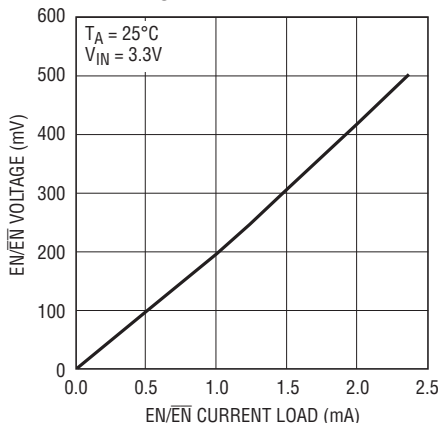

2954 G12

EN (LTC2954-1) Voltage vs V_{IN}

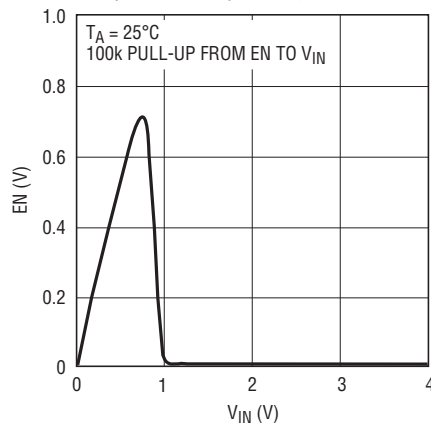

2954 G13

$\overline{\text{EN}}$ (LTC2954-2) Voltage vs V_{IN}

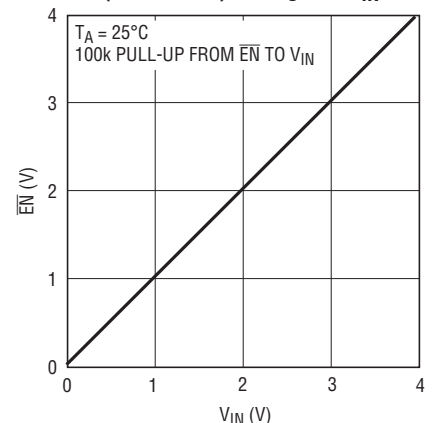

2954 G14

PIN FUNCTIONS (TSOT-23/DFN)

V_{IN} (Pin 1/Pin 4): Power Supply Input: 2.7V to 26.4V.

P \bar{B} (Pin 2/Pin 3): Pushbutton Input. Connecting P \bar{B} to ground through a momentary switch provides on/off control via the EN/ $\bar{E}N$ and $\bar{I}N\bar{T}$ outputs. An internal 100k pull-up resistor connects to an internal 1.9V bias voltage. The rugged P \bar{B} input withstands ± 10 kV ESD HBM and can be pulled up to 26.4V externally without consuming extra current.

ONT (Pin 3/Pin 2): Turn-On Time Input. Placing an external capacitor to ground determines the additional time (6.4 seconds/ μ F) the P \bar{B} pin must be held low before the enable output is asserted. Floating this pin results in a default turn on debounce time of 32ms.

GND (Pin 4/Pin 1): Device Ground.

$\bar{I}N\bar{T}$ (Pin 5/Pin 8): Open Drain Interrupt Output. After a pushbutton turn-off event is detected ($t_{DB,OFF}$), the LTC2954 interrupts the system (μ P) by asserting the $\bar{I}N\bar{T}$ pin low. The μ P would perform power-down and housekeeping tasks and then assert the $\bar{K}ILL$ pin low, thus releasing the enable output. The $\bar{I}N\bar{T}$ pulse width is a minimum of 32ms and stays low as long as P \bar{B} is asserted. If P \bar{B} is asserted for longer than $t_{PD,MIN} + t_{PDT}$, the $\bar{I}N\bar{T}$ and EN/ $\bar{E}N$ outputs are immediately released.

EN (LTC2954-1, Pin 6/Pin 7): Open Drain Enable Output. This pin is intended to enable system power. EN is asserted high after a valid P \bar{B} turn-on event ($t_{DB,ON} + t_{ONT}$). EN is released low if: a) $\bar{K}ILL$ is not driven high (by μ P) within 512ms of the initial valid P \bar{B} power turn-on event, b) $\bar{K}ILL$ is driven low during normal operation, c) P \bar{B} is pressed

and held low ($t_{PD,MIN} + t_{PDT}$) during normal operation. This pin can connect directly to a DC/DC converter shutdown pin that provides an internal pull-up. Otherwise a pull-up resistor to an external supply is required. The operating range for this low leakage pin is 0V to 26.4V.

$\bar{E}N$ (LTC2954-2, Pin 6/Pin 7): Open Drain Enable Bar Output. This pin is intended to enable system power. $\bar{E}N$ is asserted low after a valid P \bar{B} turn-on event ($t_{DB,ON} + t_{ONT}$). $\bar{E}N$ releases high if: a) $\bar{K}ILL$ is not driven high (by μ P) within 512ms of the initial valid P \bar{B} power turn-on event, b) $\bar{K}ILL$ is driven low during normal operation, c) P \bar{B} is pressed and held low ($t_{PD,MIN} + t_{PDT}$) during normal operation. This pin can connect directly to a DC/DC converter shutdown pin that provides an internal pull-up. Otherwise a pull-up resistor to an external supply is required. The operating range of this pin is 0V to 26.4V.

PDT (Pin 7/Pin 6): Power-Down Time Input. A capacitor to ground determines the additional time (6.4 seconds/ μ F) that the pushbutton must be held low before immediately releasing the EN/ $\bar{E}N$ and $\bar{I}N\bar{T}$ outputs. Floating this pin results in a pushbutton power-down time of 64ms.

$\bar{K}ILL$ (Pin 8/Pin 5): Kill Input. Forcing $\bar{K}ILL$ low releases the enable output. During system turn-on, this pin is blanked by a 512ms internal timer ($t_{KILL,ON\ BLANK}$) to allow the system to pull $\bar{K}ILL$ high. This pin has an accurate 0.6V threshold and can be used as a voltage monitor input. If unused, connect to a low voltage output supply (see Figure 6).

Exposed Pad (Pin 9 DFN Only): Exposed Pad may be left open or connected to device ground.

BLOCK DIAGRAM

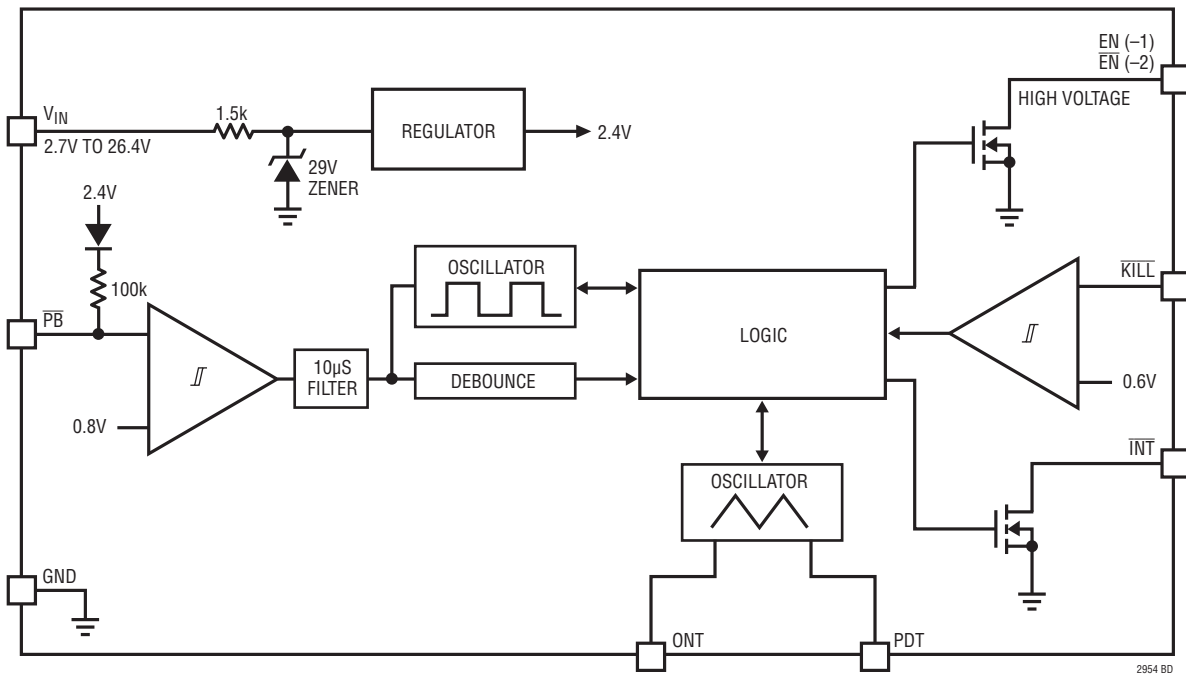

TIMING DIAGRAMS

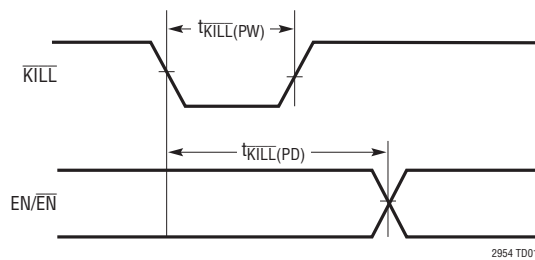

TIMING DIAGRAMS

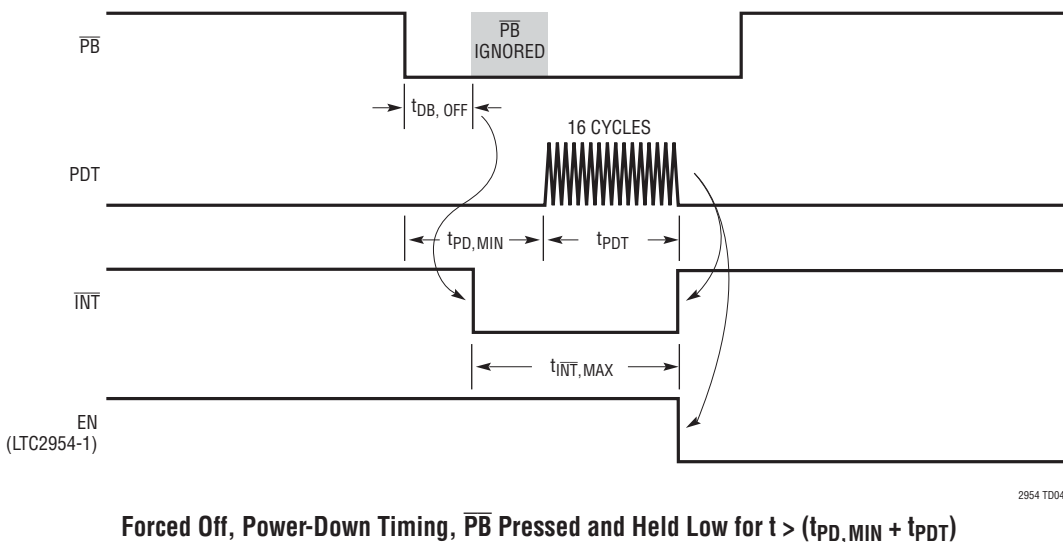
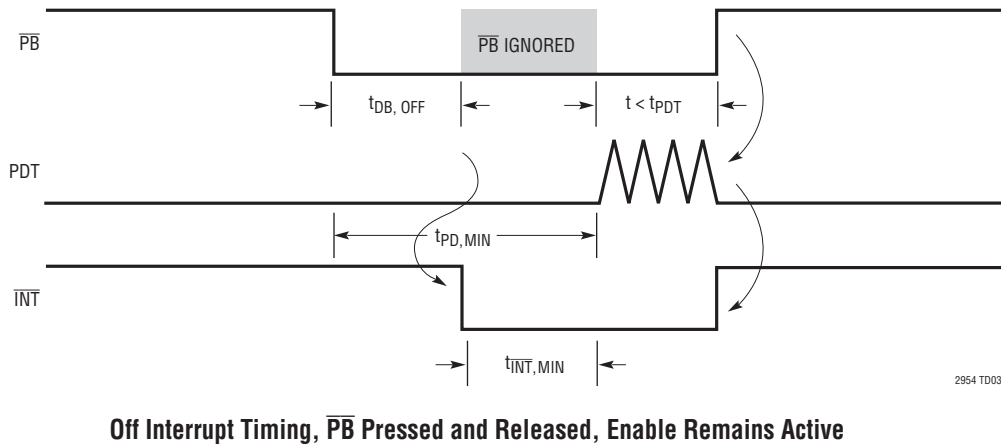
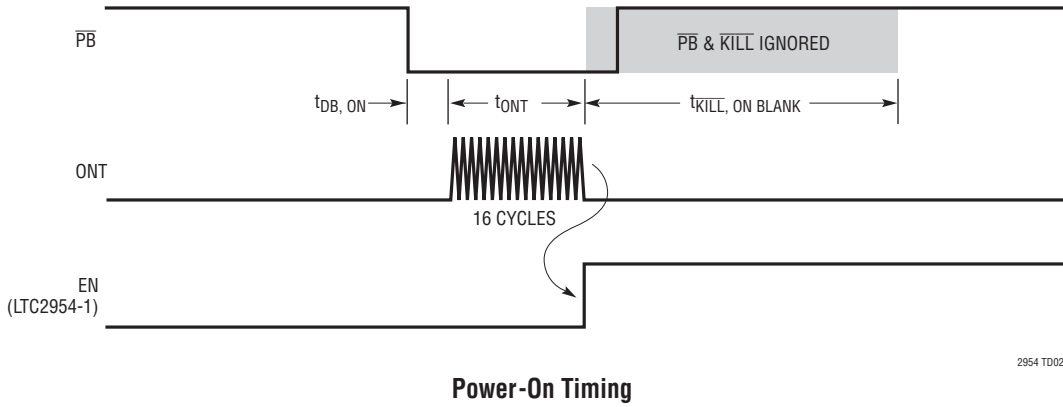

APPLICATIONS INFORMATION

Description

The LTC2954 is a pushbutton on/off controller that provides control of system power via a pushbutton interface. An enable output toggles system power while an interrupt output provides debounced pushbutton status. The interrupt output can be used in menu driven applications to request a system power-down. A power kill input allows a microprocessor or system to release the enable output, effectively powering down the system. Independently adjustable on and off timers allow dependable pushbutton control of the enable output and resistance to accidental toggling of system power.

The length of time the pushbutton input (\overline{PB}) must be held low in order to toggle the enable (EN/\overline{EN}) output on and off is independently adjustable with external capacitors at the ONT/PDT pins, respectively. During normal operation, the interrupt output (\overline{INT}) is asserted 32ms after \overline{PB} goes low. \overline{INT} then tracks \overline{PB} until either \overline{PB} or EN/\overline{EN} is released. See Timing Diagrams on page 8.

The \overline{KILL} input is used to immediately release the enable output. During a normal power-down sequence, \overline{INT} requests a system power-down. The μP then performs its housekeeping tasks and then sets \overline{KILL} low. If the μP fails to set \overline{KILL} low, the user can force a system shutdown by pressing and holding the pushbutton until the PDT timer expires.

Turn On

When power is first applied to the LTC2954, the part initializes the output pins. Any DC/DC converters connected to the EN/\overline{EN} pin will therefore be held off. To assert the enable output, \overline{PB} must be held low for a minimum of 32ms ($t_{DB,ON}$). The LTC2954 provides additional turn-on debounce time (t_{ONT}) via an optional capacitor connected to the ONT pin. The following equation describes the additional time that \overline{PB} must be held low before asserting the enable output. C_{ONT} is the ONT external capacitor (μF):

$$C_{ONT} = 1.56 \times 10^{-4} [\mu F/ms] \cdot (t_{ONT} - 1ms)$$

Once the enable output is asserted, any DC/DC converters connected to this pin are turned on. The \overline{KILL} input from the μP is ignored during a succeeding 512ms blanking time ($t_{KILL,ON\ BLANK}$). This blanking time represents the

maximum time required to power up the DC/DC converter and the μP . If \overline{KILL} is not brought high during this 512ms time window, the enable output is released. The assumption is that 512ms is sufficient time for the system to power up.

Turn Off

To initiate a power-down sequence, assert the \overline{INT} output low by pressing the pushbutton for a minimum of 32ms ($t_{DB,OFF}$). The interrupt signal serves as a power-down request to the μP . The μP would then perform power-down and housekeeping tasks and assert \overline{KILL} low when done. This in turn releases the enable output, thus shutting off system power.

Adjustable Power-Down Timer

The LTC2954 provides a failsafe feature that allows the user to turn off system power (via \overline{PB}) under system fault conditions. For cases when the μP fails to respond to the interrupt signal, the user can force an immediate power-down by pressing and holding down the pushbutton. The length of time that \overline{PB} must be held low is given by a fixed internal 64ms delay ($t_{PD,MIN}$) plus an adjustable power-down timer delay (t_{PDT} , see Timing Diagrams on page 8). The adjustable delay is set by placing an optional external capacitor on the PDT pin. Use the following equation to calculate the capacitance for the desired delay. C_{PDT} is the PDT external capacitor (μF):

$$C_{PDT} = 1.56 \times 10^{-4} [\mu F/ms] \cdot (t_{PDT} - 1ms)$$

Simplified Power On/Off Sequence

Figure 1 shows a simplified LTC2954-1 power-on and power-off sequence. A high to low transition on \overline{PB} (t_1) initiates the power on sequence. In order to assert the enable output, the \overline{PB} pin must stay low continuously (\overline{PB} high resets timers) for a time controlled by the default 32ms and the external ONT capacitor ($t_2 - t_1$). Once EN goes high (t_2), an internal 512ms blanking timer is started. This blanking timer is designed to give sufficient time for the DC/DC converter to reach its final voltage, and to allow the μP enough time to perform power-on tasks.

The \overline{KILL} pin must be pulled high within 512ms of the EN pin going high. Failure to do so results in the EN pin going

APPLICATIONS INFORMATION

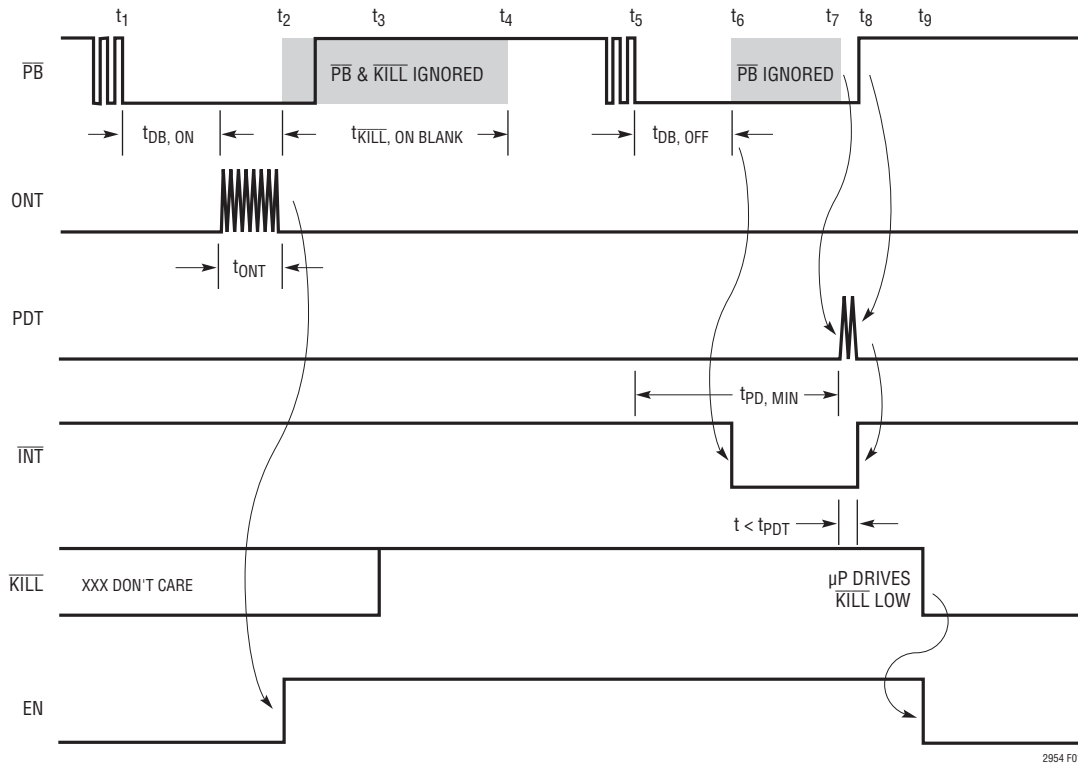

Figure 1. Simplified Power On/Off Sequence for LTC2954-1. μP Asserts \overline{KILL} After an Interrupt

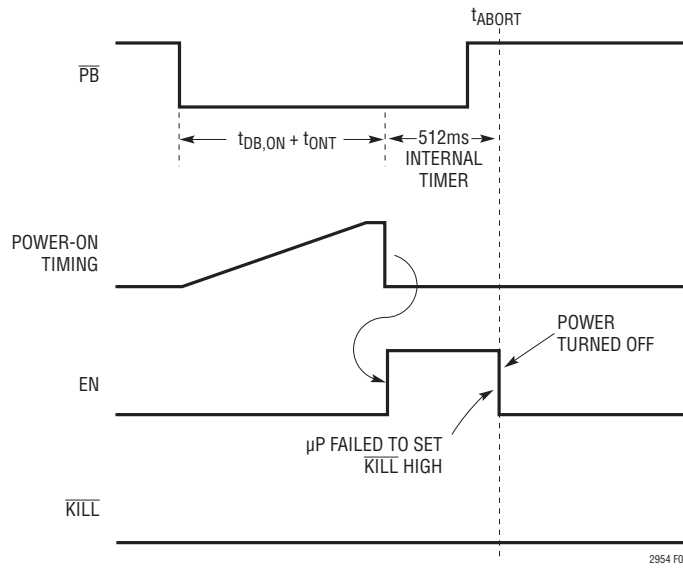

Figure 2. \overline{KILL} Remaining Low Aborts Power-On Sequence for LTC2954-1

APPLICATIONS INFORMATION

low 512ms after it went high. Note that the LTC2954 does not sample $\overline{\text{KILL}}$ and $\overline{\text{PB}}$ until after the 512ms internal timer has expired. The reason $\overline{\text{PB}}$ is ignored is to ensure that the system is not forced off while powering on. Once the 512ms timer expires (t_4), the release of the $\overline{\text{PB}}$ pin is then debounced with an internal 32ms timer. The system has now properly powered on and the LTC2954 monitors $\overline{\text{PB}}$ and $\overline{\text{KILL}}$ for a turn-off command while consuming only 6 μA of supply current.

A high to low transition on $\overline{\text{PB}}$ (t_5) starts the power-off sequence debounce timer. In order to assert the interrupt output ($\overline{\text{INT}}$), $\overline{\text{PB}}$ must stay low continuously ($\overline{\text{PB}}$ high resets debounce timer) for 32ms ($t_6 - t_5$). At the completion of the power-down debounce timer (t_6), an internal interrupt timer keeps the interrupt output low for at least 32ms, even if $\overline{\text{PB}}$ is released between t_6 and t_7 . If $\overline{\text{PB}}$ is low at the end of this 32ms internal timer (t_7), the external adjustable power-down timer is started. The capacitor placed at the PDT pin will determine the time period of this timer. If the pushbutton is released prior to 16 cycles of the PDT pin, the interrupt output will go high (t_8). Note that the enable output is not directly changed by this interrupt pulse. The function of the interrupt signal is to initiate a software shutdown. At t_9 , the μP has performed its power-down functions and asserted the $\overline{\text{KILL}}$ input low. This releases the enable output, which in turn shuts down system power. Note that if the pushbutton is held long enough to count 16 cycles at the PDT pin, the enable pin would be released immediately after the 16th cycle. The system is now in its reset state where the LTC2954 is in low power mode (6 μA) and $\overline{\text{PB}}$ is monitored for a high to low transition.

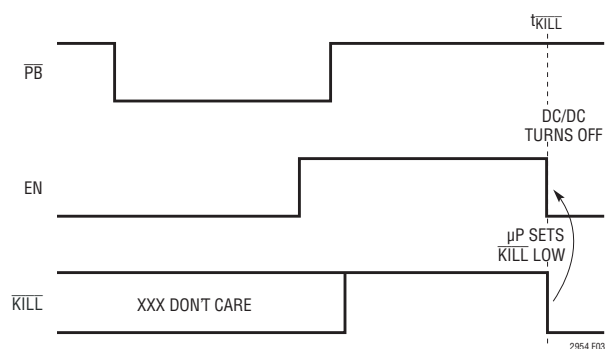

Figure 3. μP Turns Off Power (LTC2954-1)

Aborted Power-On Sequence

The power-on sequence is aborted when the $\overline{\text{KILL}}$ remains low at the end of the 512ms blanking time. Figure 2 is a simplified version of an aborted power-on sequence. At time t_{ABORT} , since $\overline{\text{KILL}}$ is still low, EN pulls low (thus turning off the DC/DC converter).

μP Turns Off Power During Normal Operation

Once the system has powered on and is operating normally, the μP can turn off power by setting $\overline{\text{KILL}}$ low, as shown in (Figure 3). At time $t_{\overline{\text{KILL}}}$, $\overline{\text{KILL}}$ is set low by the μP . This immediately pulls EN low, thus turning off the DC/DC converter.

DC/DC Turn Off Blanking

When the DC/DC converter is turned off, it can take a significant amount of time for its output to decay to ground. It is desirable to wait until the output of the DC/DC converter is near ground before allowing the user (via $\overline{\text{PB}}$) to restart the converter. This condition guarantees that the μP has always powered down completely before it is restarted.

Figure 4 shows the μP turning power off. After a low on $\overline{\text{KILL}}$ releases enable, the internal 256ms timer ignores the $\overline{\text{PB}}$ pin. This is shown as $t_{\text{EN}/\overline{\text{EN}}}$, LOCKOUT in (Figure 4).

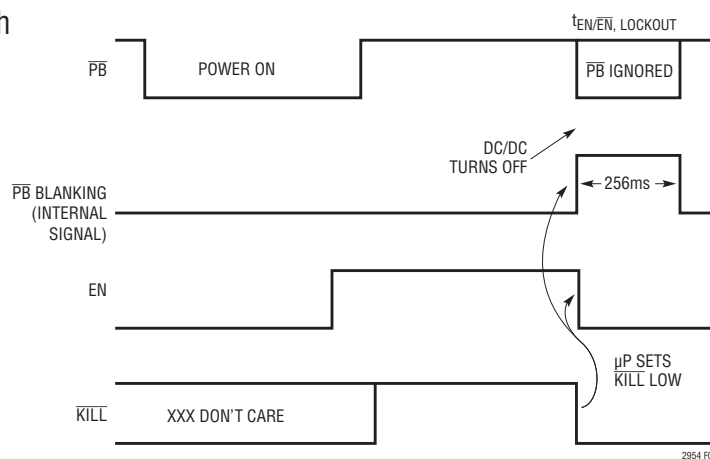

Figure 4. DC/DC Turn-Off Blanking (LTC2954-1)

APPLICATIONS INFORMATION

LTC2954-1, LTC2954-2 Versions

The LTC2954-1 (high true EN) and LTC2954-2 (low true $\overline{\text{EN}}$) differ only by the polarity of the high voltage (33V ABS MAX), enable pin. The LTC2954-1 EN pin is a low leakage high true open drain output designed to drive the shutdown pin of DC/DC converters. The LTC2954-2 is a low leakage, low true open drain enable output designed to drive the gate of an external PFET. The LTC2954-2 provides a user manual power path control.

High Voltage Pins

The V_{IN} , $\overline{\text{PB}}$ and $\text{EN}/\overline{\text{EN}}$ pins can operate at voltages up to 26.4V. $\overline{\text{PB}}$ can, additionally, operate below ground (-6V)

without latching up the device. $\overline{\text{PB}}$ has an ESD HBM rating of $\pm 10\text{kV}$. If the pushbutton switch connected to $\overline{\text{PB}}$ exhibits high leakage current, then an external pull-up resistor to V_{IN} is recommended. Furthermore, if the pushbutton switch is physically located far from the LTC2954 $\overline{\text{PB}}$ pin, parasitic capacitances may couple onto the high impedance $\overline{\text{PB}}$ input. Additionally, parasitic series inductance may cause unpredictable ringing at the $\overline{\text{PB}}$ pin. Placing a 5.1k resistor from the $\overline{\text{PB}}$ pin to the pushbutton switch would mitigate parasitic inductance problems. Placing a 0.1 μF capacitor on the $\overline{\text{PB}}$ pin would lessen the impact of parasitic capacitive coupling.

TYPICAL APPLICATIONS

Voltage Monitoring with $\overline{\text{KILL}}$ Input

The $\overline{\text{KILL}}$ pin can be used as a voltage monitor. Figure 5 shows an application where the $\overline{\text{KILL}}$ pin has a dual function. It is driven by a low leakage open drain output of the μP . It is also connected to a resistive divider that monitors battery voltage (V_{IN}). When the battery voltage falls below the set value, the voltage at the $\overline{\text{KILL}}$ pin falls below 0.6V and the EN pin is quickly pulled low. Note that the resistor values should be as large as possible, but small

enough to keep leakage currents from tripping the 0.6V $\overline{\text{KILL}}$ comparator.

The DC/DC converter shown has an internal pull-up current on its $\overline{\text{SHDN}}$ pin. A pull-up resistor on EN is thus not needed.

Operation Without μP

Figure 6 shows how to connect the $\overline{\text{KILL}}$ pin when there is no circuitry available to drive it. The minimum pulse

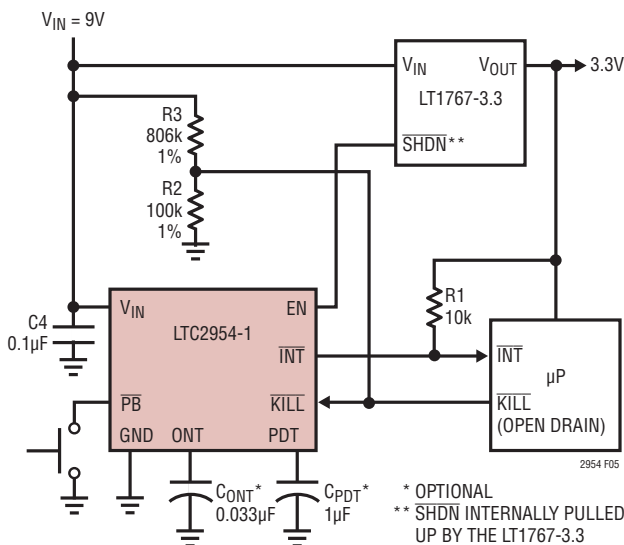

Figure 5. Input Voltage Monitoring with $\overline{\text{KILL}}$ Input

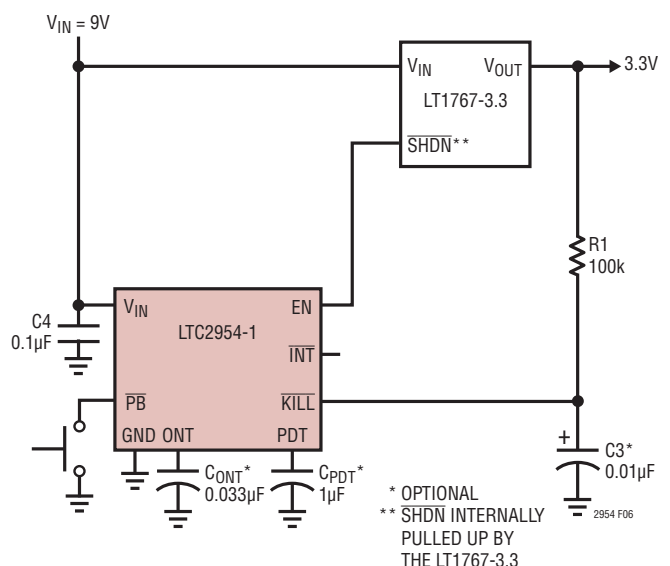

Figure 6. No μP Application

TYPICAL APPLICATIONS

width detected is $30\mu\text{s}$. If there are glitches on the resistor pull-up voltage that are wider than $30\mu\text{s}$ and transition below 0.6V , then an appropriate bypass capacitor should be connected to the $\overline{\text{KILL}}$ pin. The optional C_{PDT} external capacitor extends the length of time (beyond 64ms) that the $\overline{\text{PB}}$ input must be held low before releasing the enable output.

High Voltage PowerPath Switching

The high voltage $\overline{\text{EN}}$ open drain output of the LTC2954-2 is designed to switch on/off an external power PFET. This allows a user to connect/disconnect a power supply (or battery) to its load by toggling the $\overline{\text{PB}}$ pin. Figure 7 shows the LTC2954-2 controlling a two cell Li-Ion battery application. The $\overline{\text{KILL}}$ pin is connected to the output of the

PFET through a resistive divider. The $\overline{\text{KILL}}$ pin serves as a voltage monitor. When V_{OUT} drops below 6V , causing a $\overline{\text{KILL}}$ voltage below $V_{\overline{\text{KILL}}(\text{TH})}$, the $\overline{\text{EN}}$ pin becomes an open circuit $30\mu\text{s}$ later. Since the PDT pin is open-circuited, the power-down debounce time defaults to 64ms .

$\overline{\text{PB}}$ Pin in a Noisy Environment

The rugged $\overline{\text{PB}}$ pin is designed to operate in noisy environments. Transients below ground ($>-6\text{V}$) and above V_{IN} ($<33\text{V}$) will not damage the rugged $\overline{\text{PB}}$ pin. Additionally, the $\overline{\text{PB}}$ pin can withstand ESD HBM strikes up to $\pm 10\text{kV}$.

In order to keep external noise from coupling inside the LTC2954, place an R-C network close to the $\overline{\text{PB}}$ pin. A 5.1k resistor and a $0.1\mu\text{F}$ capacitor should suffice for most noisy applications (see Figure 8).

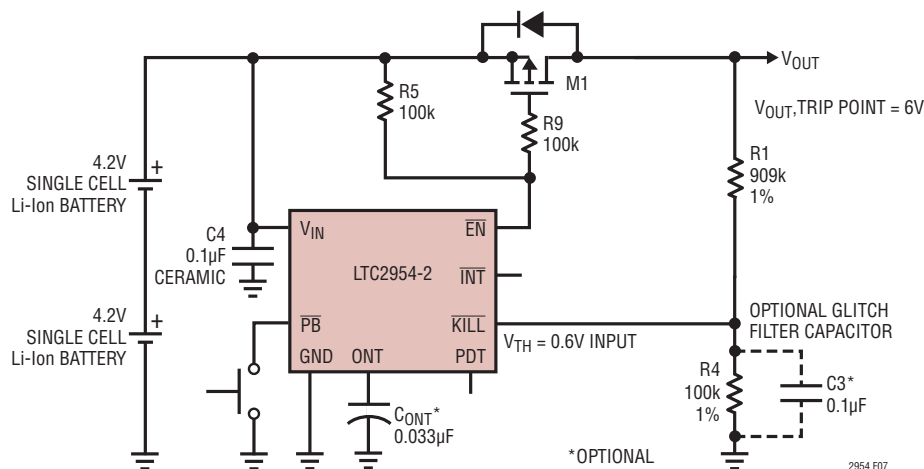

Figure 7. PowerPath Control with 6V Undervoltage Detect

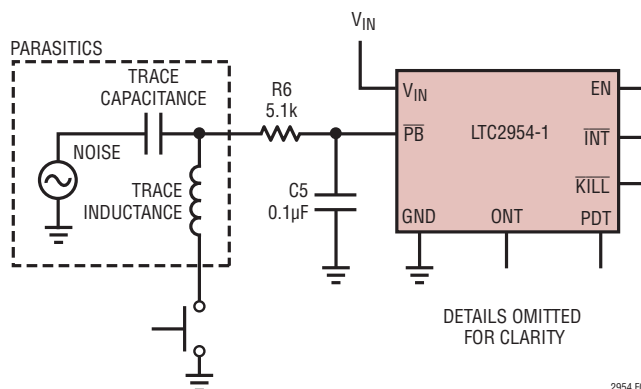

Figure 8. Noisy $\overline{\text{PB}}$ Trace

TYPICAL APPLICATIONS

External Pull-Up Resistor On \overline{PB}

An internal pull-up resistor on the \overline{PB} pin makes an external pull-up resistor unnecessary. Leakage current on the \overline{PB} board trace, however, will affect the open circuit voltage on the \overline{PB} pin. If the leakage is too large ($>2\mu\text{A}$), the \overline{PB} voltage may fall close to the threshold window. To mitigate the effect of the board leakage, a 10k resistor to V_{IN} is recommended (see Figure 9).

Reverse Battery Protection

To protect the LTC2954 from a reverse battery connection, place a 1k resistor in series with the V_{IN} pin (see Figure 10).

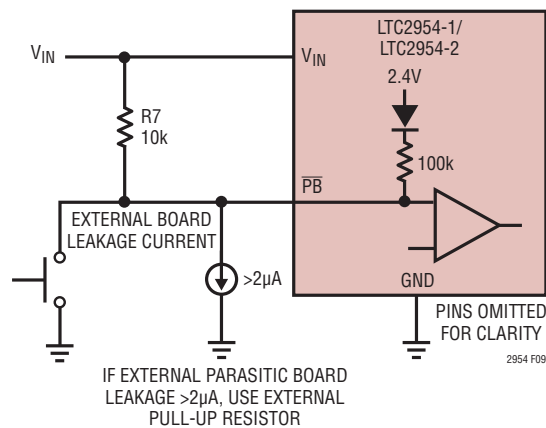
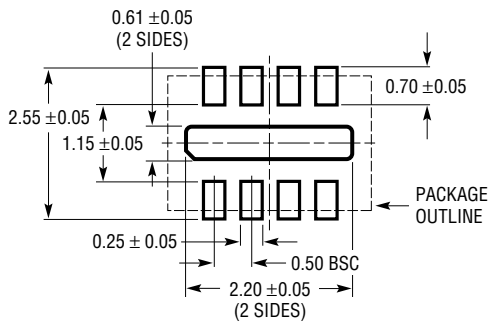

Figure 9. External Pull-Up Resistor On \overline{PB} Pin

PACKAGE DESCRIPTION

DDB Package 8-Lead Plastic DFN (3mm x 2mm) (Reference LTC DWG # 05-08-1702 Rev B)



RECOMMENDED SOLDER PAD PITCH AND DIMENSIONS

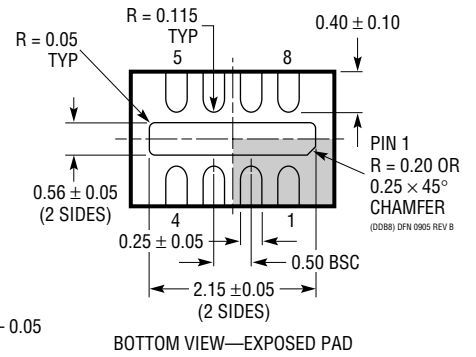
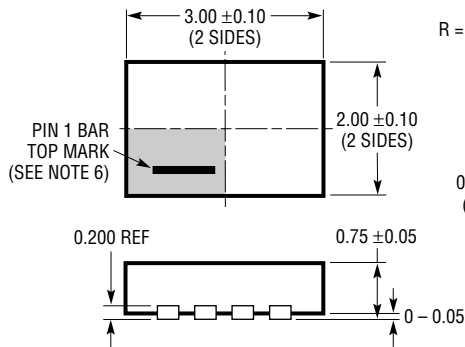

NOTE:

1. DRAWING CONFORMS TO VERSION (WECD-1) IN JEDEC PACKAGE OUTLINE M0-229
2. DRAWING NOT TO SCALE
3. ALL DIMENSIONS ARE IN MILLIMETERS
4. DIMENSIONS OF EXPOSED PAD ON BOTTOM OF PACKAGE DO NOT INCLUDE MOLD FLASH. MOLD FLASH, IF PRESENT, SHALL NOT EXCEED 0.15mm ON ANY SIDE
5. EXPOSED PAD SHALL BE SOLDER PLATED
6. SHADED AREA IS ONLY A REFERENCE FOR PIN 1 LOCATION ON THE TOP AND BOTTOM OF PACKAGE

PACKAGE DESCRIPTION

TS8 Package
8-Lead Plastic TSOT-23
 (Reference LTC DWG # 05-08-1637 Rev A)

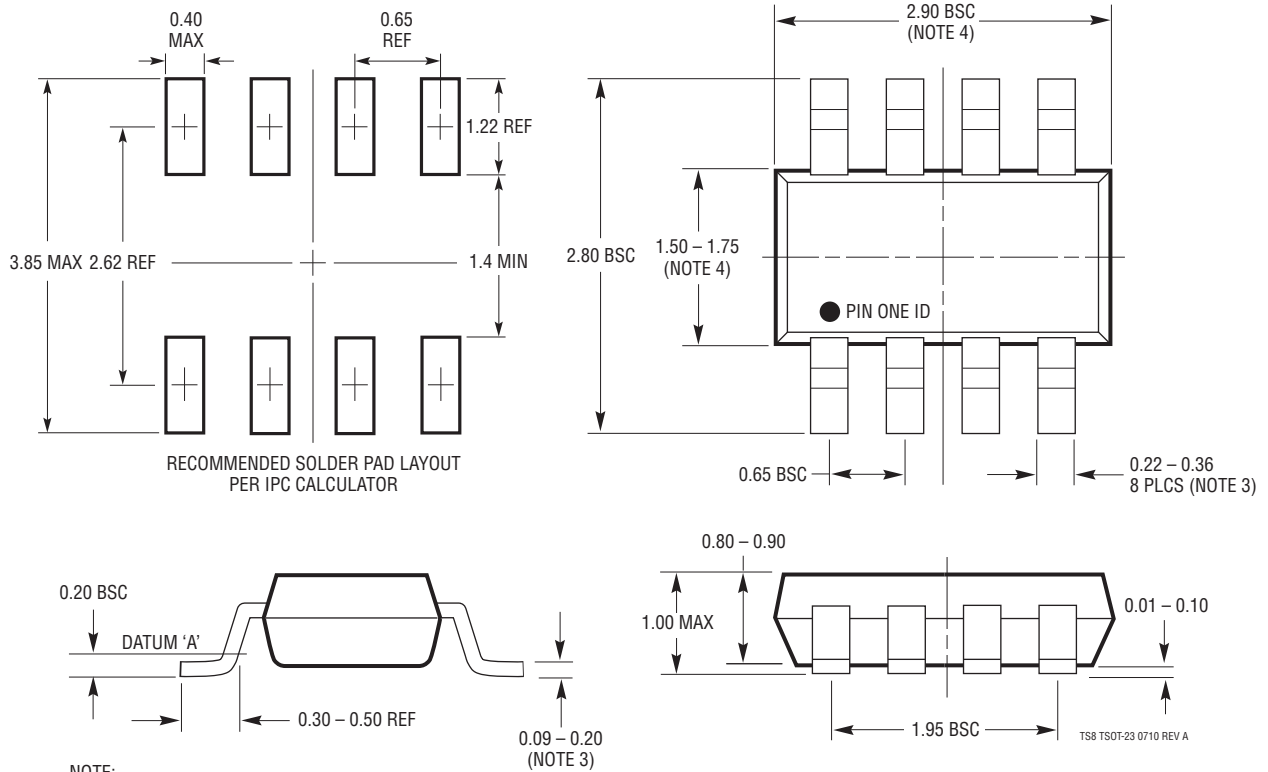

- NOTE:
1. DIMENSIONS ARE IN MILLIMETERS
 2. DRAWING NOT TO SCALE
 3. DIMENSIONS ARE INCLUSIVE OF PLATING
 4. DIMENSIONS ARE EXCLUSIVE OF MOLD FLASH AND METAL BURR
 5. MOLD FLASH SHALL NOT EXCEED 0.254mm
 6. JEDEC PACKAGE REFERENCE IS MO-193

REVISION HISTORY (Revision history begins at Rev B)

REV	DATE	DESCRIPTION	PAGE NUMBER
B	2/11	Revised Pin Descriptions for EN and $\overline{\text{EN}}$ pins	6
		Revised notes for Figures 5 and 6 in Typical Applications	12

TYPICAL APPLICATION

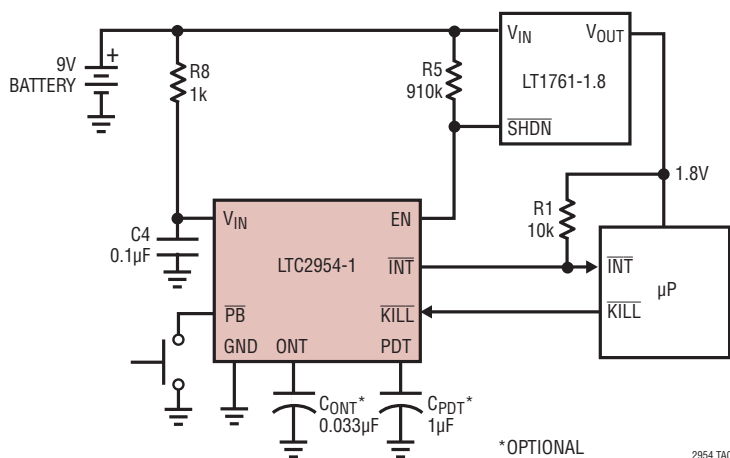

Figure 10. Reverse Battery Protection

RELATED PARTS

PART NUMBER	DESCRIPTION	COMMENTS
LTC2900	Programmable Quad Supply Monitor	Adjustable RESET, 10-Lead MSOP and 3mm × 3mm DFN Packages
LTC2904/LTC2905	Pin-Programmable Dual Supply Monitors	Adjustable RESET and Tolerance, 8-Lead SOT-23 and 3mm × 2mm DFN Packages
LTC2909	Precision Triple/Dual Input UV, OV and Negative Voltage Monitor	6.5V Shunt Regulator for High Voltage Operation
LTC2910	Octal Positive/Negative Voltage Monitor	Eight Adjustable Inputs (0.5V)
LTC2914	Quad UV/OV Positive/Negative Voltage Monitor	Adjustable UV and OV Trip Values
LTC2950/LTC2951	Pushbutton On/Off Controllers	High Voltage, Low Power Pushbutton Controller with Power-Down Fault Detect KILL Timer
LTC4411	2.6A Low Loss Ideal Diode in ThinSOT	No External MOSFET, Automatic Switching Between DC Sources
LTC4412HV	Power Path Controller in ThinSOT	Efficient Diode-ORing, Automatic Switching Between DC Sources, 3V to 36V
LTC4055	USB Power Controller and Li-Ion Charger	Automatic Switchover, Charges 1-Cell Li-Ion Batteries
LT4351	MOSFET Diode-OR Controller	Wide Input Range: 1.2V to 18V
LTC2952	Pushbutton PowerPath™ Controller with Supervisor	Automatic Low Loss Switchover Between DC Sources
LTC2953	Pushbutton ON/OFF Controller with Voltage Monitoring	High Voltage Pushbutton Controller with 200ms Voltage Reset Monitor

X-ON Electronics

Largest Supplier of Electrical and Electronic Components

Click to view similar products for [Supervisory Circuits](#) category:

Click to view products by [Analog Devices](#) manufacturer:

Other Similar products are found below :

[NCP304LSQ38T1G](#) [NCP304LSQ42T1G](#) [NCP304LSQ43T1G](#) [NCP305LSQ11T1G](#) [NCP305LSQ16T1G](#) [NCP305LSQ17T1G](#)

[NCP305LSQ18T1G](#) [NCP305LSQ24T1G](#) [NCP305LSQ25T1G](#) [NCP305LSQ29T1G](#) [NCP305LSQ31T1G](#) [NCP305LSQ32T1G](#)

[NCP308MT250TBG](#) [NCP308SN300T1G](#) [NCP391FCALT2G](#) [NCV303LSN42T1G](#) [NCV308SN330T1G](#) [CAT1161LI-25-G](#) [CAT853STBI-T3](#)

[CAT1026LI-30-G](#) [CAT1320LI-25-G](#) [CAT872-30ULGT3](#) [NCP304HSQ18T1G](#) [NCP304HSQ29T1G](#) [NCP304LSQ27T1G](#) [NCP304LSQ29T1G](#)

[NCP304LSQ45T1G](#) [NCP305LSQ26T1G](#) [NCP305LSQ35T1G](#) [NCP305LSQ37T1G](#) [NCP308MT300TBG](#) [NCV300LSN36T1G](#)

[NCV302LSN30T1G](#) [NCV303LSN16T1G](#) [NCV303LSN22T1G](#) [NCV303LSN27T1G](#) [NCV33161DMR2G](#) [TC54VN2402EMB713](#)

[MCP1316T-44NE/OT](#) [MCP1316MT-45GE/OT](#) [MCP1316MT-23LI/OT](#) [MCP1316T-26LE/OT](#) [MAX8997EWW+](#) [MAX821RUS+T](#)

[MAX6725AKASYD3-LF-T](#) [MAX809SEUR](#) [MAX6701LKA+](#) [MAX16126TCA+T](#) [MAX16046ATN+](#) [NCP303LSN09T2G](#)