



ON Semiconductor®

<http://onsemi.com>

LB11970RV

Monolithic Digital IC For Fan Motor Single-phase Full-wave Driver

Overview

The LB11970RV is a motor driver of the single phase bipolar drive that a good direct PWM drive of the motor drive efficiency can come true easily. It is most suitable for the power supply fan of the personal computer, CPU air conditioner fan drive.

Functions

- Single-phase full-wave drive (16V to 1.2A output transistor incorporated)
- Variable speed function using thermistor input and external signal incorporated
→ Enables silent and low-vibration variable speed control through direct PWM control with separately-excited upper Tr
- Current limiter circuit (limit at $I_O=480\text{mA}$ with $R_L=1\Omega$ connection, the limiter value determined with Rf)
- Kick-back absorption circuit incorporated
- Low-consumption, low-loss, and low-noise drive enabled by the soft switching circuit during phase shift
- Regeneration Di incorporated with less external parts
- HB incorporated
- Lock protection and automatic reset functions incorporated
- RD (Lock detection) output
- Thermal shutdown circuit incorporated

Specifications

Absolute Maximum Ratings at $T_a = 25^\circ\text{C}$

Parameter	Symbol	Conditions	Ratings	Unit
V _{CC} maximum supply voltage	V _{CC} max		17	V
V _M maximum supply voltage	V _M max		17	V
OUT pin maximum output current	I _{OUT} max		1.2	A
OUT pin output withstand voltage	V _{OUT} max		18	V
HB maximum output current	HB		10	mA
V _{TH} , RMI input pin withstand voltage	V _{TH} RMI max		7	V
P-IN input pin withstand voltage	V _{P-IN} max		V _{CC}	V
RD output pin output withstand voltage	V _{RD} max		18	V
RD output current	I _{RD} max		10	mA
Allowable power dissipation	P _d max	Specified substrate *	0.8	W
Operating temperature range	T _{opr}		-30 to 90	°C
Storage temperature range	T _{stg}		-55 to 150	°C

* Specified substrate: 30mm×30mm×0.8mm, paper phenol.

Caution 1) Absolute maximum ratings represent the value which cannot be exceeded for any length of time.

Caution 2) Even when the device is used within the range of absolute maximum ratings, as a result of continuous usage under high temperature, high current, high voltage, or drastic temperature change, the reliability of the IC may be degraded. Please contact us for the further details.

Stresses exceeding Maximum Ratings may damage the device. Maximum Ratings are stress ratings only. Functional operation above the Recommended Operating Conditions is not implied. Extended exposure to stresses above the Recommended Operating Conditions may affect device reliability.

LB11970RV

Recommended Operating Ranges at $T_a = 25^\circ\text{C}$

Parameter	Symbol	Conditions	Ratings	Unit
V_{CC} supply voltage	V_{CC}		4.5 to 16	V
VM supply voltage	VM		3.5 to 16	V
VTH, RMI input level voltage range	VTH, RMI		0 to 6	V
P-IN input level voltage range	VP-IN		0 to V_{CC}	V
Triangular wave input range	VRM		0.5 to 4	V
Hall input common phase input voltage range	VICM		0.2 to 3	V

Electrical Characteristics at $T_a = 25^\circ\text{C}$, $V_{CC} = 12\text{V}$, $R_f = 0\Omega$, unless otherwise specified.

Parameter	Symbol	Conditions	Ratings			unit
			min	typ	max	
Circuit current	I_{CC1}	During drive	12	15	18	mA
	I_{CC2}	During lock protection	11	14	17	mA
HB voltage	VHB	IHB=5mA	1.12	1.22	1.32	V
6VREG voltage	V6VREG	I6VREG=5mA	5.85	5.95	6.10	V
CT pin H level voltage	V_{CTH}		3.4	3.6	3.8	V
CT pin L level voltage	V_{CTL}		1.4	1.6	1.8	V
CT pin charge current	I_{CT1}		1.8	2.2	2.6	μA
CT pin discharge current	I_{CT2}		0.18	0.22	0.26	μA
CT charge/discharge current ratio	R_{CT}		8	10	12	
OUT output L saturation voltage	V_{OL}	$I_O=200\text{mA}$		0.1	0.2	V
OUT output H saturation voltage	V_{OH}	$I_O=200\text{mA}$, $R_f=1\Omega$		0.6	0.8	V
Current limiter	VRF			480		mV
RD output pin L voltage	V_{RD}	$I_{RD}=5\text{mA}$		0.2	0.3	V
RD output pin leak current	$I_{RD L}$	$V_{RD}=18\text{V}$			30	μA
Overheat protection circuit	THD	* Design guarantee value		180		$^\circ\text{C}$

*: Design target value and no measurement were made.

LB11970RV

Package Dimensions

unit : mm (typ)
3338

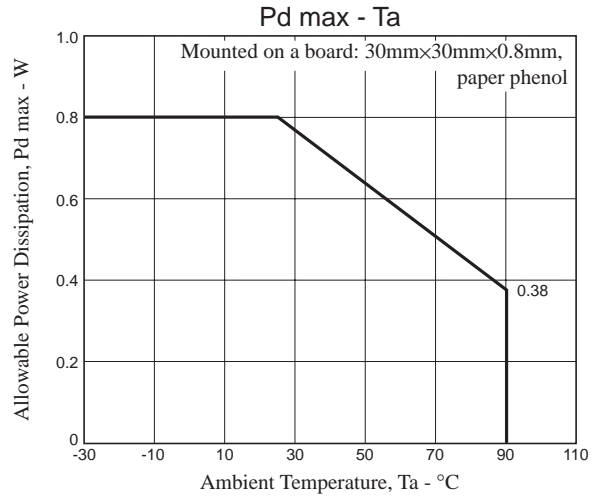
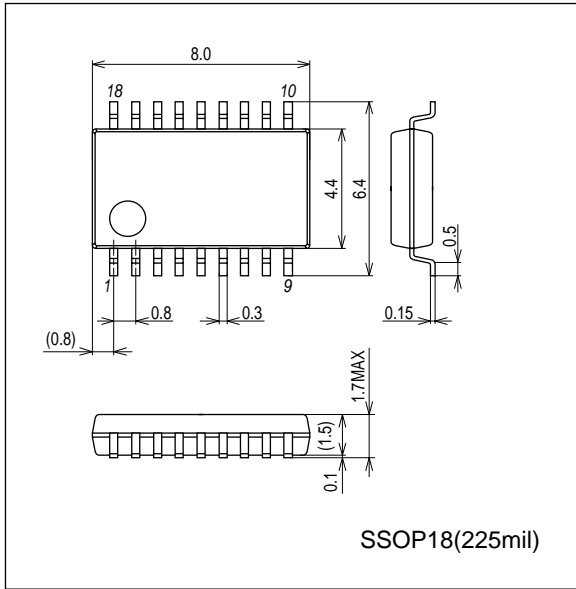

Pin Assignment

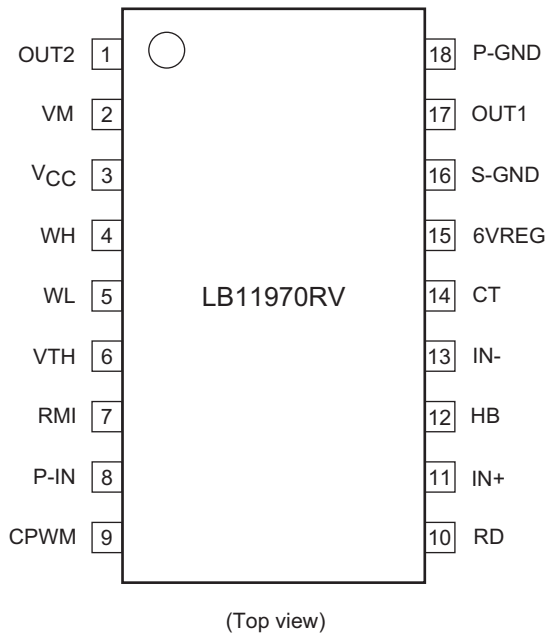

PGND: Motor system GND
SGND: Control system GND

Equivalent Circuit Diagram

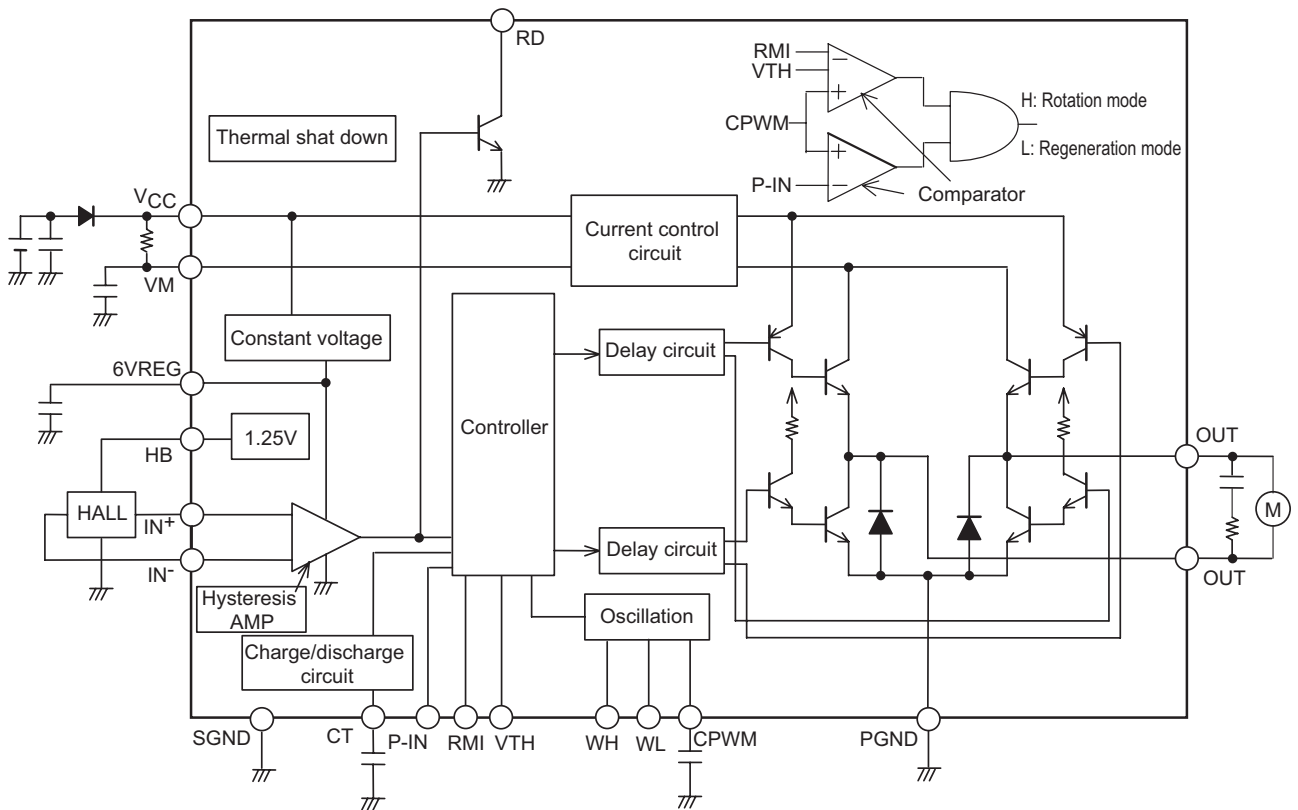

Truth Table

VTH	PIN	IN-	IN+	CT	OUT1	OUT2	RD	Mode
L (OPEN)	L	H	L	L	H	L	L	Running - drive
	L	L	H		L	H		
H	L	H	L		OFF	L		Running - regeneration
	L	L	H		L	OFF		
-	H	H	L	L	OFF	L	Output regeneration mode with external signal	
-	H	L	H		L	OFF		
-	-	H	L	H	OFF	L	OFF	Lock protection
-	-	L	H	H	L	OFF		

VTH, P-IN = L means VTH, P-IN < CPWM VTH, P-IN = H means VTH, P-IN > CPWM

Application Circuit Example

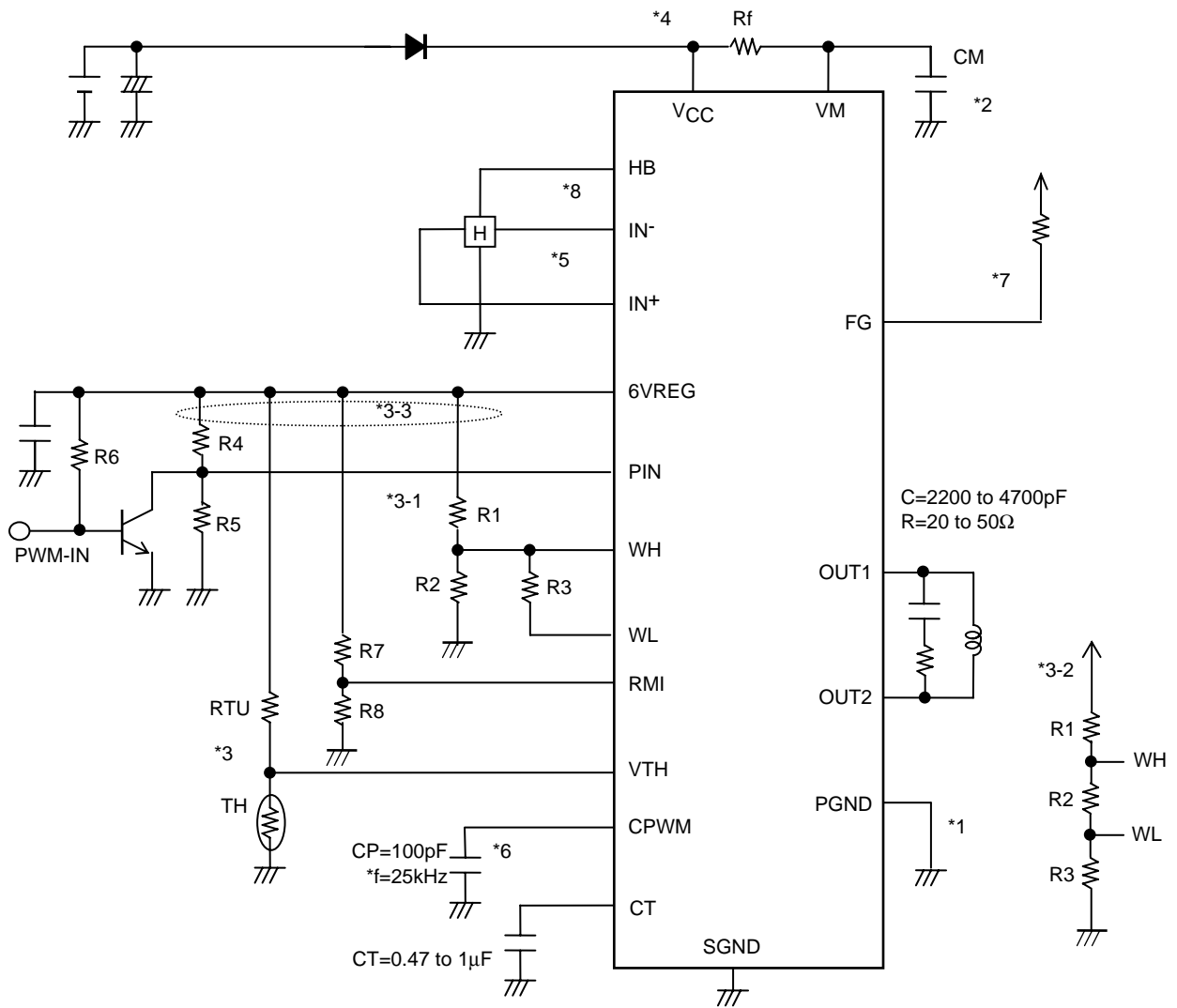

*1. Power supply - GND wiring

PGND is connected to the motor power system while SGND is connected to the control circuit power system. Wiring is made separately for PGND and SGND, and external parts of each control system are connected to SGND.

*2. Power stabilization capacitor for regeneration

CM capacitor is a power stabilizing capacitor for PWM drive and kick-back absorption and has the capacitance of 4.7 μ F or more. Since this IC performs current regeneration with the lower Tr through switching of the upper Tr, connect CM with the thick and shortest possible pattern between VM and PGND.

*3. Setting of the temperature detection variable speed

Setting of the triangular wave oscillation voltage

The rotation speed variable range for the temperature is set with the triangular wave oscillation voltage.

There are two setting methods as follows:

3-1 The upper voltage (VCPH) of triangular wave is determined by $V \times (\text{voltage of the R1 connection counterpart}) \times (R2/(R1+R2))$ and the lower voltage (VCPL) of triangular wave is determined by $V \times ((R2//R3) / (R1+R2//R3))$.

3-2 The upper voltage (VCPH) of triangular wave is determined by $V \times ((R2+R3) / (R1+R2+R3))$ and the lower voltage (VCPL) of triangular wave is determined by $V \times (R2/(R1+R2))$.

Setting of the thermostat

The resistance (RTU from VCC or 6VREG and the voltage generated through division of thermostat (TH) are input in the VTH pin. When the voltage at the VTH pin drops below VCPL due to temperature change, the full speed (thermostat input speed control side only) is obtained.

To set the full speed with the thermostat tripping, connect each pin of 3-3 to VCC and each input voltage is generated by divided resistance from VCC. When the thermostat trips and the VTH pin is pulled up to VCC, the full speed (thermostat input speed control side only) is obtained.

*4. Setting the current limiter

The current limiter is activated when the voltage between current detection resistors exceeds 0.48V between VCC and VM.

The current limiter is activated at $I_O = 480\text{mA}$ when $R_L = 1\Omega$. Setting is made with the Rf resistance.

Short-circuit VCC and VM when the current limiter is not to be used.

When 12V is used, the current limiter must be applied at 1A or less if the coil resistance is 10 Ω or less.

*5. Hall input

Wiring must be as short as possible to prevent carrying of noise. The Hall input circuit is a comparator with hysteresis of 20mV. The Hall input level is recommended to be three times (60mVp-p) or more of this hysteresis.

*6. Capacitor to set the PWM oscillation frequency

Oscillation with $f = 25\text{kHz}$ occurs at $CP = 100\text{pF}$ and PWM voltage width of 1.6V, and becomes the reference frequency of PWM.

*7. RD output

This is the open collector output, the output "H (OFF)" at the time of "L", and a stop at the time of a turn. Keep this output OPEN when not used.

*8. HB pin

Hall element bias pin, which is a 1.22V constant-voltage output pin

*9. RMI pin

Minimum speed setting pin for thermostat speed control, which must be pulled up with 6 VREG when not used. By connecting the capacitor, the time to ignore thermostat input at startup can be set.

*10. PIN pin

Direct PWM speed control pin. Pull down the P-IN input to GND when not using this pin.

The lowest output DUTY setting is made with R4 and R5. Keep R5 open for stop with DUTY at 0%.

ON Semiconductor and the ON logo are registered trademarks of Semiconductor Components Industries, LLC (SCILLC). SCILLC owns the rights to a number of patents, trademarks, copyrights, trade secrets, and other intellectual property. A listing of SCILLC's product/patent coverage may be accessed at www.onsemi.com/site/pdf/Patent-Marking.pdf. SCILLC reserves the right to make changes without further notice to any products herein. SCILLC makes no warranty, representation or guarantee regarding the suitability of its products for any particular purpose, nor does SCILLC assume any liability arising out of the application or use of any product or circuit, and specifically disclaims any and all liability, including without limitation special, consequential or incidental damages. "Typical" parameters which may be provided in SCILLC data sheets and/or specifications can and do vary in different applications and actual performance may vary over time. All operating parameters, including "Typicals" must be validated for each customer application by customer's technical experts. SCILLC does not convey any license under its patent rights nor the rights of others. SCILLC products are not designed, intended, or authorized for use as components in systems intended for surgical implant into the body, or other applications intended to support or sustain life, or for any other application in which the failure of the SCILLC product could create a situation where personal injury or death may occur. Should Buyer purchase or use SCILLC products for any such unintended or unauthorized application, Buyer shall indemnify and hold SCILLC and its officers, employees, subsidiaries, affiliates, and distributors harmless against all claims, costs, damages, and expenses, and reasonable attorney fees arising out of, directly or indirectly, any claim of personal injury or death associated with such unintended or unauthorized use, even if such claim alleges that SCILLC was negligent regarding the design or manufacture of the part. SCILLC is an Equal Opportunity/Affirmative Action Employer. This literature is subject to all applicable copyright laws and is not for resale in any manner.

X-ON Electronics

Largest Supplier of Electrical and Electronic Components

Click to view similar products for [Motor/Motion/Ignition Controllers & Drivers](#) category:

Click to view products by [ON Semiconductor](#) manufacturer:

Other Similar products are found below :

[LV8133JA-ZH](#) [LV8169MUTBG](#) [LV8774Q-AH](#) [LV8860PV-TLM-H](#) [MC33931EKR2](#) [MC34GD3000EP](#) [FSB50250UTD](#) [FSB50550TB2](#)
[FSBF15CH60BTH](#) [MP6507GR-P](#) [MP6508GF](#) [MSVCPM2-63-12](#) [MSVGW45-14-2](#) [MSVGW54-14-5](#) [NTE7043](#) [CAT3211MUTAG](#)
[LA6245P-CL-TLM-E](#) [LA6245P-TLM-E](#) [LA6565VR-TLM-E](#) [LB11650-E](#) [LB1694N-E](#) [LB1837M-TLM-E](#) [LB1845DAZ-XE](#) [LC898111AXB-](#)
[MH](#) [LC898300XA-MH](#) [SS30-TE-L-E](#) [STK531-345A-E](#) [STK581U3A0D-E](#) [STK58AUNP0D-E](#) [STK621-068C-E](#) [STK621-140C](#) [STK621-](#)
[728S-E](#) [STK625-728-E](#) [STK672-400B-E](#) [STK672-432AN-E](#) [STK672-432BN-E](#) [STK672-440AN-E](#) [STK672-442AN-E](#) [AMIS30621AUA](#)
[FSB50550ASE](#) [26700](#) [LV8161MUTAG](#) [LV8281VR-TLM-H](#) [LV8702V-TLM-H](#) [LV8734VZ-TLM-H](#) [LV8773Z-E](#) [LV8807QA-MH](#)
[MC33932EK](#) [MCP8024T-H/MP](#) [TND027MP-AZ](#)