



Features

- RoHS compliant*
- Power rating at 70 °C: CR2010 - 1/2 W, CR2512 - 1 W
- Tight tolerances of bottom electrode width
- Three layer termination process with nickel barrier prevents leaching and provides excellent solderability
- Suitable for most types of soldering processes
- Standard packaging on tape and reel
- AEC-Q200 approval upon request

CR2010/CR2512 - Chip Resistors

Electrical Characteristics

Characteristic	Model CR2010	Model CR2512
Power Rating @ 70 °C	1/2 W	1 W
Operating Temperature Range	-55 °C to +155 °C	
Derated to 0 Load at	+155 °C	
Maximum Working Voltage	200 V	
Maximum Overload Voltage	400 V	
Resistance Range: 1 % E-96 + E-24	10 ohms ≤ R ≤ 1M ohms ±100 PPM/°C 1M ohms < R ≤ 10M ohms ±200 PPM/°C	
Resistance Range: 5 % E-24	10 ohms ≤ R ≤ 10M ohms ±200 PPM/°C 1 ohm ≤ R < 10 ohms 10M ohms < R ≤ 20M ohms ±400 PPM/°C	
Zero Ohm Jumper <0.05 ohm Rated/Maximum Current	2 A/5 A	2 A/5 A

Chip Dimensions

Dimension	Model CR2010	Model CR2512
L	$\frac{5.00 \pm 0.20}{(0.197 \pm 0.008)}$	$\frac{6.30 \pm 0.20}{(0.248 \pm 0.008)}$
W	$\frac{2.50 \pm 0.20}{(0.098 \pm 0.008)}$	$\frac{3.10 \pm 0.20}{(0.122 \pm 0.008)}$
H	$\frac{0.60 \pm 0.10}{(0.024 \pm 0.004)}$	$\frac{0.60 \pm 0.15}{(0.024 \pm 0.006)}$
l1	$\frac{0.60 \pm 0.25}{(0.024 \pm 0.010)}$	$\frac{0.60 \pm 0.25}{(0.024 \pm 0.010)}$
l2	$\frac{0.60 \pm 0.25}{(0.024 \pm 0.010)}$	$\frac{0.60 \pm 0.25}{(0.024 \pm 0.010)}$

Derating Curve

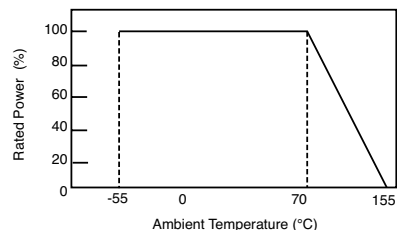

For Standard Values Used in Capacitors, Inductors, and Resistors, [click here](#).

Dimensional Drawing

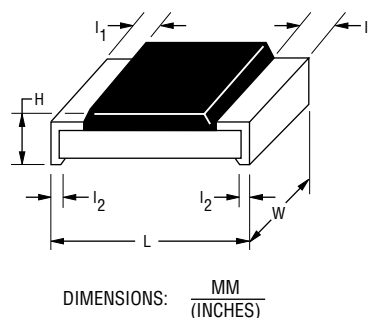

Performance Characteristics

Test	Procedure	Method	Test Limits ΔR	
			1 %	5 %
Thermal Shock	-55 °C for 30 minutes, +155 °C for 30 minutes, 5 cycles	IEC60115-1-4.19	≤±(0.5 % + 0.05 Ω)	≤±(1 % + 0.05 Ω)
Short Time Overload	2.5 X rated voltage for 5 seconds	IEC60115-1-4.13	≤±(1 % + 0.05 Ω)	
Resistance to Solder Heat	270 ±5 °C for 10 ±1 seconds	IEC60115-1-4.18	≤±(0.5 % + 0.05 Ω)	≤±(1 % + 0.05 Ω)
Resistance to Dry Heat	125 ±5 °C for 96 ±4 hours	IEC60115-1-4.23.2	≤±(1 % + 0.05 Ω)	≤±(2 % + 0.1 Ω)
Load Life	Rated voltage for 1000 hours, 70 °C, 1.5 hours "ON", 0.5 hours "OFF"	IEC60115-1-4.25.1	≤±(1 % + 0.05 Ω)	≤±(3 % + 0.1 Ω)
Load Life with Humidity	Rated voltage for 1000 hours, 40 ±2 °C, 90~95 % RH, 1.5 hours "ON", 0.5 hours "OFF"	IEC60115-1-4.24	≤±(1 % + 0.05 Ω)	≤±(3 % + 0.1 Ω)
Solderability	245 ±5 °C, 2 ±0.5 seconds	IEC60115-1-4.17	≥95 % of area covered	
Bending	3 mm	IEC60115-1-4.33	≤±(0.5 % + 0.05 Ω)	≤±(1 % + 0.05 Ω)
Dielectric Withstanding Voltage	--	IEC60115-1-4.7	>500 V	
Insulation Resistance	100 V	IEC60115-1-4.6	≥1 GΩ	

*RoHS Directive 2002/95/EC Jan. 27, 2003 including annex and RoHS Recast 2011/65/EU June 8, 2011.

Specifications are subject to change without notice.

The device characteristics and parameters in this data sheet can and do vary in different applications and actual device performance may vary over time. Users should verify actual device performance in their specific applications.

CR2010/CR2512 - Chip Resistors

BOURNS®

How to Order

CR 2010 - F X - 8252 E LF

Model _____ (CR = Chip Resistor)

Size _____
 • 2010
 • 2512

Resistance Tolerance _____
 F = ±1 % Use with "X" TCR code only for values from 10 ohms through 1 megohm;
 Use with "W" TCR code only for values from 1 megohm through 10 megohms
 J = ±5 % Use with "W" TCR code for values from 10 ohms through 10 megohms;
 Use with "Z" TCR code for values above 10 megohms through 20 megohms;
 Use with "/" TCR code for zero ohm (jumper) and values from 1 ohm through 9.1 ohms.

TCR (ppm/°C) _____
 X = ±100
 W = ±200
 Z = ±400
 / = Used with "J" Resistance Tolerance code for zero ohm (jumper) and values from 1 ohm through 9.1 ohms.

Resistance Value _____
 For 1 % Tolerance:
 <100 ohms....."R" represents decimal point (example: 24R3 = 24.3 ohms)
 ≥100 ohms.....First three digits are significant, fourth digit represents number of zeros to follow (example: 8252 = 82.5k W)
 For 5 % Tolerance:
 <10 ohms "R" represents decimal point (example: 4R7 = 4.7 ohms)
 ≥10 ohms.....First two digits are significant, third digit represents number of zeros to follow (example: 474 = 470k ohms; 000 = Jumper)

Packaging _____
 E = Embossed Plastic Tape (4,000 pcs.) on 7 " Plastic Reel

Termination _____
 LF = Tin-plated (RoHS compliant)

Soldering Profile for RoHS Compliant Chip Resistors and Arrays

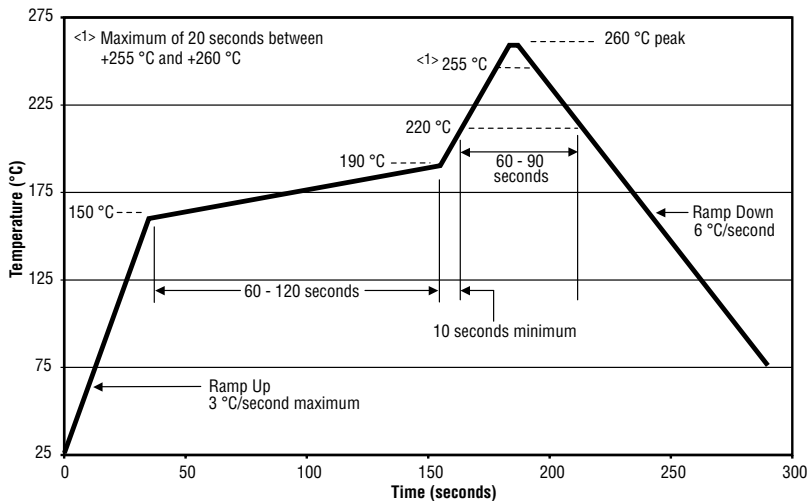

Marking Explanation

Resistors with 5 % tolerance may have a 3-digit or 4-digit resistance code. Complete information about resistance value and tolerance is found on the label of the reel of chip resistors.

- 5 %: 3 digits, first two digits are significant, third digit is number of zeros to follow. Letter R is decimal point for values from 1 to 9.9 ohms.
- 5 %: 4 digits, first three digits are significant, fourth digit is number of zeros to follow. Letter R is decimal point for values from 1 to 99.9 ohms.
- 1 %: 4 digits, first three digits are significant, fourth digit is number of zeros to follow. Letter R is decimal for values from 1 to 99.9 ohms.

CR2010/CR2512 - Chip Resistors

BOURNS®

Packaging Dimensions

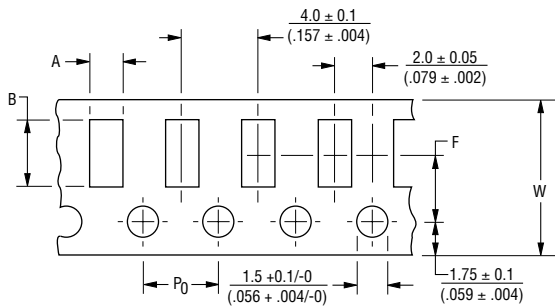

Dimension	Model CR2010	Model CR2512
A	$\frac{2.8 \pm 0.2}{(0.110 \pm 0.008)}$	$\frac{3.5 \pm 0.2}{(0.138 \pm 0.008)}$
B	$\frac{5.5 \pm 0.2}{(0.217 \pm 0.008)}$	$\frac{6.7 \pm 0.2}{(0.264 \pm 0.008)}$
W	$\frac{12.0 \pm 0.3}{(0.472 \pm 0.012)}$	$\frac{12.0 \pm 0.3}{(0.472 \pm 0.012)}$
F	$\frac{5.5 \pm 0.05}{(0.217 \pm 0.002)}$	$\frac{5.5 \pm 0.05}{(0.217 \pm 0.002)}$
P0	$\frac{4.0 \pm 0.1}{(0.157 \pm 0.004)}$	$\frac{4.0 \pm 0.1}{(0.157 \pm 0.004)}$

DIMENSIONS: $\frac{\text{MM}}{\text{(INCHES)}}$

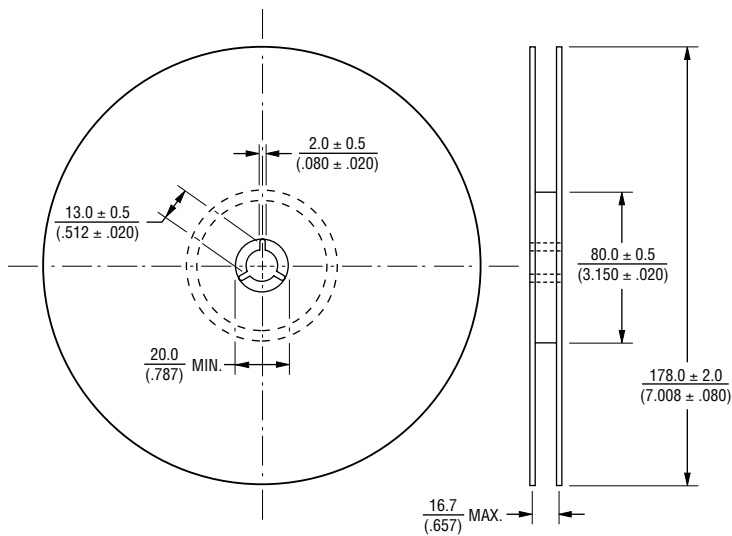

REV. 07/15

Specifications are subject to change without notice.
 The device characteristics and parameters in this data sheet can and do vary in different applications and actual device performance may vary over time.
 Users should verify actual device performance in their specific applications.

X-ON Electronics

Largest Supplier of Electrical and Electronic Components

Click to view similar products for [Thick Film Resistors - SMD category](#):

Click to view products by [Bourns manufacturer](#):

Other Similar products are found below :

[CRCW04028R20JNEE](#) [CRCW06036K80FKEE](#) [CRG1206F1K58](#) [CRL0603-FW-R700ELF](#) [M55342K06B6E19RWL](#) [RC1005F1072CS](#)
[RC1005F471CS](#) [RC1005F4751CS](#) [ERJ-1GMF1R00C](#) [ERJ-1GMF1R20C](#) [ERJ-1GMF2R55C](#) [ERJ-1GMF8R66C](#) [25121WF1003T4E](#)
[25.501.3653.0](#) [290-1.0M-RC](#) [292-1.0M-RC](#) [292-2.2K-RC](#) [292-4.7K-RC](#) [25121WF4700T4E](#) [292-470K-RC](#) [302-1.0M-RC](#) [CPG1206F10KC](#)
[CRCW02011R00FXED](#) [CRCW060315K0FKEE](#) [CRCW060320K5FKEE](#) [CRG0201F10K](#) [RCG04023K92FKED](#) [RCWP12061K00FKS2](#)
[3520510RJT](#) [352075KJT](#) [RMC16-102JT](#) [RMC1JPTE](#) [TR0603MR-075K1L](#) [5-2176094-4](#) [35202K7JT](#) [WF06Q1000FTL](#) [ERJ-S14J4R7U](#)
[CHP2512L4R30GNT](#) [CPCC10270R0JE32](#) [WR12X1621FTL](#) [RCWP11001K00FKS3](#) [RCWP110022R1FKS3](#) [RCWP110035R7FKS3](#)
[RCWP110097R6FKS3](#) [LRC-LRF3W-01-R050-FTR1800](#) [9-2176088-6](#) [NRC06F1002TR20F](#) [CRCW02013M30FNED](#) [CRCW060343K0FKEE](#)
[WR04X5360FTL](#)