

### Features

- PCIe Gen2/ Gen3\* compliant clock buffer/ZDB
- \* Gen3 performance only available in Commercial temp
- Internal equalization for better signal integrity
- 2 HCSL outputs
- Dual PLL bandwidth for SSC tracking
- Cycle-to-Cycle Jitter : 40ps (typ)
- Output-to-Output Skew <10ps
- 3.3V supply voltage
- TSSOP-20 packages

### Applications

- Servers
- Embedded computing systems
- Networking systems

### Block Diagram

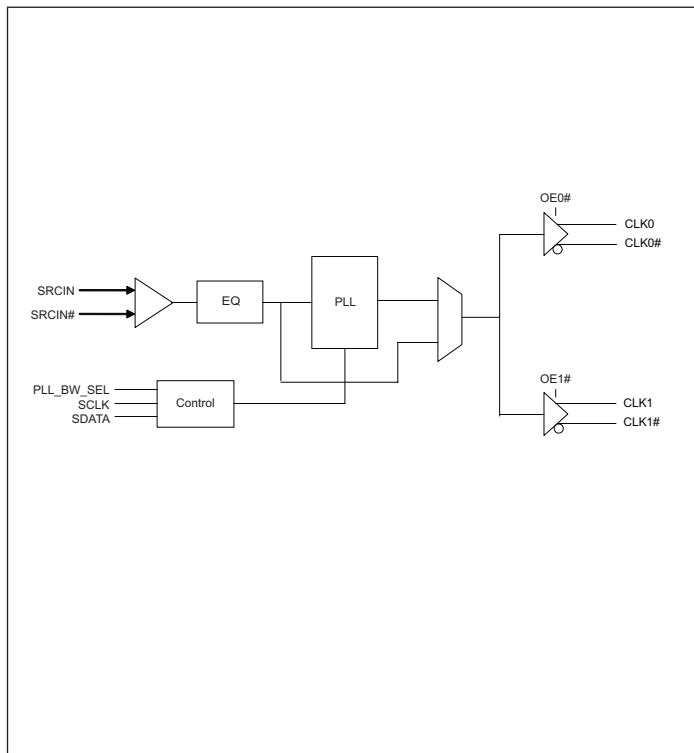

### Description

The PI6CEQ20200 is a high performance PCIe Gen2/ Gen3 zero delay buffer with two HCSL outputs. Pericom's proprietary equalization technique used in this device improves signal integrity and makes this device suitable for PCIe Gen2/ Gen3 applications even when the input from the main clock has to travel a long distance.

### Pin Configuration (20-Pin TSSOP & 20-Pin QSOP)

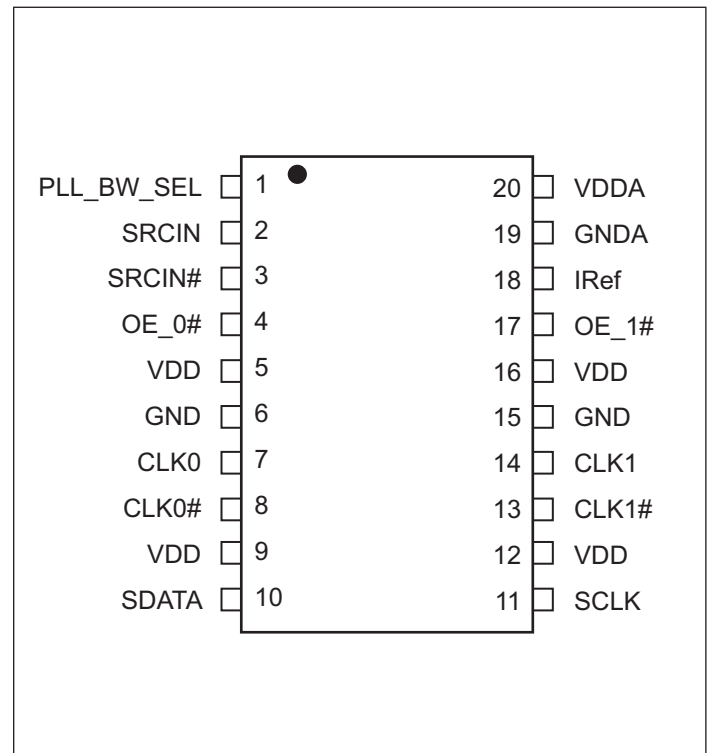

**Pin Description**

Pin #	Pin Name	Type	Description
1	PLL_BW_SEL	Input	CMOS input to select the PLL Bandwidth
2, 3	SRCIN, SRCIN#	Input	HCSL inputs
4	OE_0#	Input	Output enable for CLK0 and CLK0#. "0" is "enabled", "1" is "tri-stated. Internal pull-down
5, 9, 12, 16	VDD	Power	3.3V Power Supply
6, 15	GND	Power	Ground
7, 8	CLK0, CLK0#	Input	HCSL output
10	SDATA	Input/Output	SMBus data
11	SCLK	Input	SMBus clock input
13, 14	CKL1#, CLK1	Output	HCSL output
17	OE_1#	Input	Output enable for CLK1 and CLK1#. "0" is "enabled", "1" is "tri-stated. Internal pull-down
18	IRef	Input	External resistor connection for internal current reference
19	GNDA	Power	Analog and PLL Ground
20	VDDA	Power	Analog and PLL power supply

**Maximum Ratings** (Above which the useful life may be impaired. For user guidelines, not tested)

Storage temperature.....	-65°C to +155°C
Ambient Temperature with Power Applied.....	-40°C to +85°C
3.3V Analog Supply Voltage .....	-0.5 to +4.6V
ESD Protection(HBM) .....	2000V

**Note:**

Stresses greater than those listed under MAXIMUM RATINGS may cause permanent damage to the device. This is a stress rating only and functional operation of the device at these or any other conditions above those indicated in the operational sections of this specification is not implied. Exposure to absolute maximum rating conditions for extended periods may affect reliability.

**Recommended Operating Conditions**

Symbol	Description	Test Conditions	Min	Type	Max	Unit
V <sub>DD</sub>	Power supply	-	3.135	-	3.465	V
I <sub>DD</sub>	Total Power Supply Current	-	-	-	65	mA
I <sub>DD_Output tri-stated</sub>	Total power supply current with Outputs are tri-stated	Outputs are tri-stated	-	-	30	mA
T <sub>A</sub>	Operating temperature	Commercial temperature	0		+70	°C
		Industrial temperature	-40		+85	

**LVCMOS DC Electrical Characteristics** (Over Operating Conditions)

Symbol	Parameter	Conditions	Min.	Typ.	Max.	Unit
V <sub>IH</sub>	Input High Voltage	-	2	-	V <sub>DD</sub> +0.3	V
V <sub>IL</sub>	Input Low Voltage	-	-0.3	-	0.8	V
I <sub>IH</sub>	Input High Current	V <sub>IN</sub> = V <sub>DD</sub>	-	-	45	μA
I <sub>IL</sub>	Input Low Current	V <sub>IN</sub> = 0V	-45	-	-	μA
R <sub>PU</sub>	Internal pull up resistance	-	-	120	-	kOhm
R <sub>DN</sub>	Internal pull down resistance	-	-	120	-	kOhm

**Differential DC Input Characteristics** (Over Operating Conditions)

Symbol	Parameter	Conditions	Min.	Typ.	Max.	Unit
I <sub>IH</sub>	Input High Current, IN-	V <sub>IN</sub> = V <sub>DD</sub> =3.465V	-	-	5	μA
	Input High Current, IN+				45	μA
I <sub>IL</sub>	Input Low Current, IN-	V <sub>IN</sub> = 0V	-45	-	-	μA
	Input Low Current, IN+		-5	-	-	μA
V <sub>IH</sub>	Input High Voltage	Single-ended swing	660	700	850	mV
V <sub>IL</sub>	Input Low Voltage		-150	0		mV

**HCSL DC Electrical Characteristics** (Over Operating Conditions)

Symbol	Parameter	Conditions	Min.	Typ.	Max.	Unit
V <sub>OH</sub>	Output High Voltage	-	660	-	850	mV
V <sub>OL</sub>	Output Low Voltage	-	-	-	150	mV
V <sub>CROSS</sub>	Absolute Crossing Point Voltages	-	250	-	550	mV
ΔV <sub>CROSS</sub>	Total variation of V <sub>CROSS</sub> overall edges	-	-	-	140	mV
I <sub>OH</sub>	Output High Current w/475-Ohm resistor. Connected between I <sub>REF</sub> pin and GND	-	-	14	-	mA

**HCSL AC Switching Characteristics<sup>(\*1, \*2, \*3)</sup>** (Over Operating Conditions)

Symbol	Parameter	Conditions	Min.	Typ.	Max.	Unit
F <sub>in</sub>	Input Frequency	-	90	100	110	MHz
T <sub>r</sub> /T <sub>f</sub>	Output Rise/Fall time	Between 0.175V and 0.525V <sup>*2</sup>	175	-	700	ps
ΔT <sub>r</sub> /ΔT <sub>f</sub>	Rise and Fall Time Variation <sup>*2</sup>	-	-	-	125	ps
T <sub>PD</sub>	Propagation delay in PLL mode	PLL is enabled			650	ps
T <sub>PD</sub> B <sub>P</sub>	Propagation delay in bypass mode	PLL is bypassed			4.0	ns
T <sub>skew</sub>	Output-to-Output Skew <sup>*3</sup>	-	-		10	ps
T <sub>DC</sub>	Output Duty Cycle <sup>*3</sup>	-	47	-	53	%
J <sub>C-C</sub>	Cycle to Cycle jitter	Differential waveform		40	50	ps
J <sub>HF-RMS</sub>	Phase jitter, high frequency	RMS jitter applying PCIE Gen2 jitter mask <sup>*3</sup>	-	-	3.1	ps
		RMS jitter applying PCIE Gen3 jitter mask <sup>*3</sup>		0.61	1.0	ps
J <sub>LF-RMS</sub>	Phase jitter, low frequency	RMS jitter applying PCIE Gen2 jitter mask <sup>*3</sup>	-	-	3.0	ps
		RMS jitter applying PCIE Gen3 jitter mask <sup>*3</sup> , commercial temp range only		-	3.0	ps

**HCSL AC Switching Characteristics**(\*1, \*2, \*3) (Over Operating Conditions) Continued..

Symbol	Parameter	Conditions	Min.	Typ.	Max.	Unit
PLL <sub>LBW</sub>	PLL Loop Bandwidth	PLL_BW_SEL=1	1.3		3	MHz
		PLL_BW_SEL=0	0.25		1	MHz
T <sub>OEN</sub>	OE enable time				100	ns
T <sub>OEF</sub>	OE disable time				100	ns
T <sub>SQD</sub>	Squelch detect time	Input level is less than 150mV (single-ended)		50		ns

**Notes:**

1. Test configuration is R<sub>s</sub>=33Ω, R<sub>p</sub>=49.9Ω, and 2pF
2. Measurement is taken from Single Ended waveform.
3. Measurement is taken from Differential waveform.

**HCSL Output Buffer Characteristics**

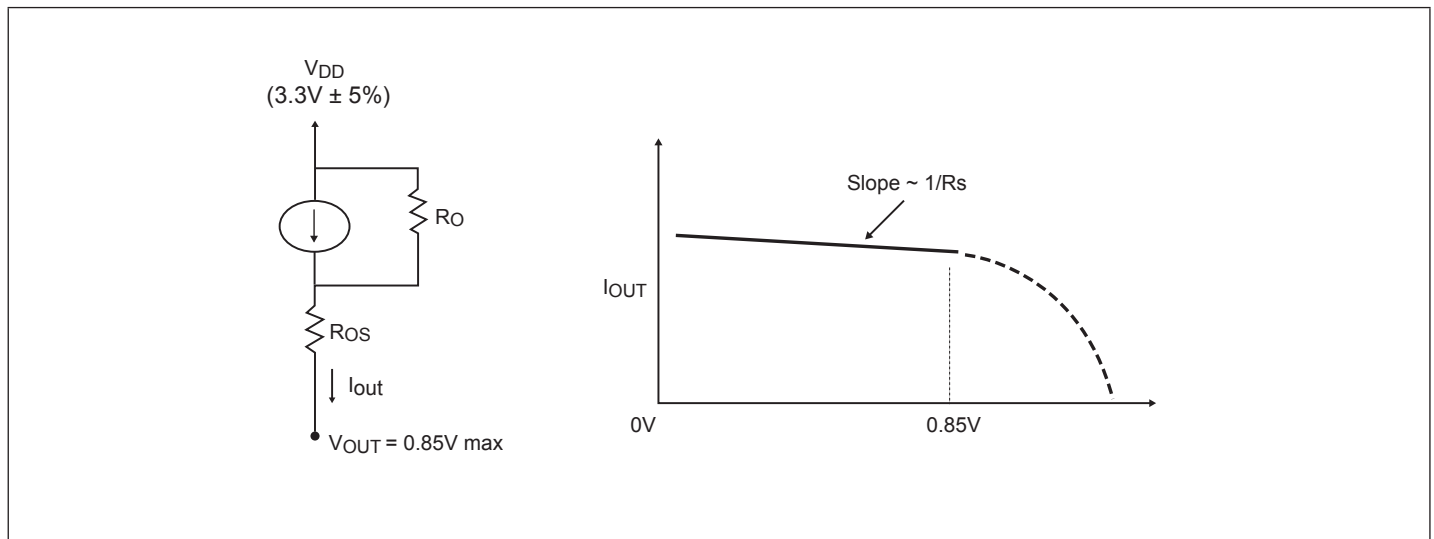

**Simplified diagram of current-mode output buffer**

**HCSL Output Buffer Characteristics**

Symbol	Minimum	Maximum
R <sub>O</sub>	3000Ω	N/A
R <sub>OS</sub>	unspecified	unspecified
V <sub>OUT</sub>	N/A	850mV

**Configuration Test Load Board Termination for HCSL Output**

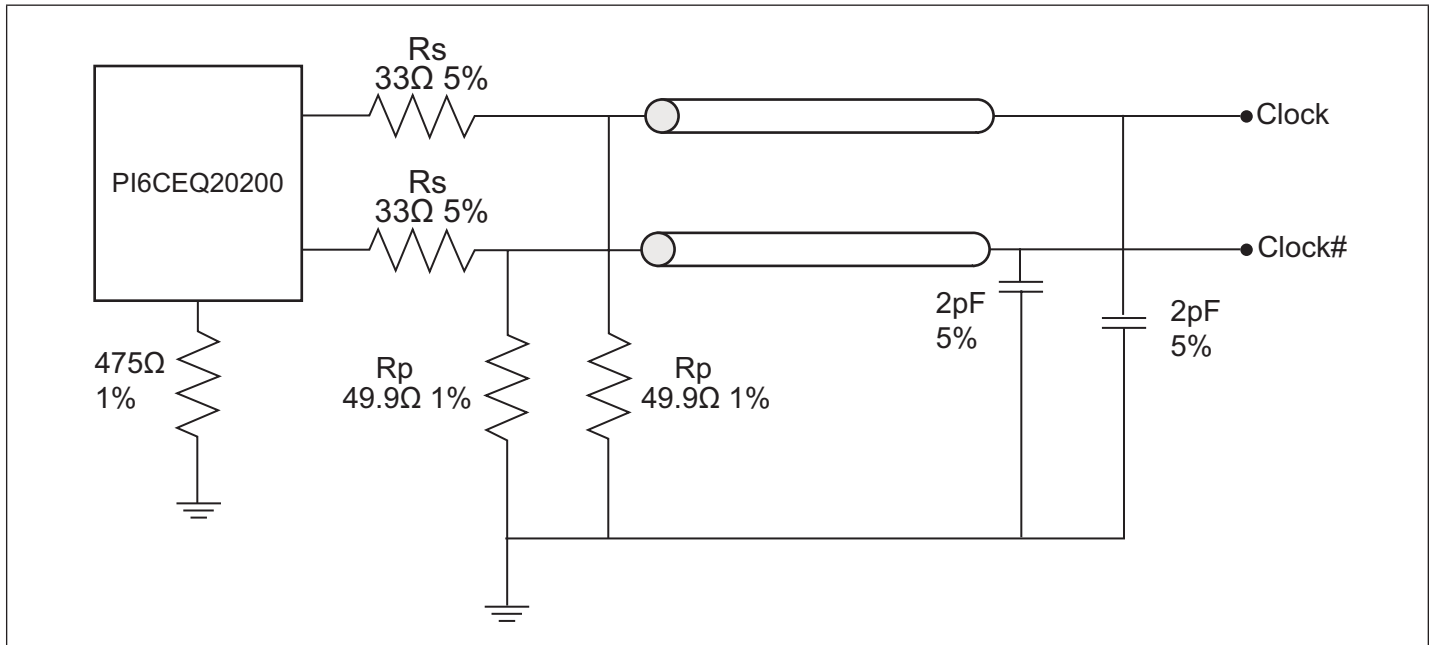

**Serial Data Interface**

This part is a slave only SMBus device that supports indexed block read and indexed block write protocol using a single 7-bit address and read/write bit as shown below.

**Address Assignment**

A6	A5	A4	A3	A2	A1	A0	W/R
1	1	0	1	0	1	0	0/1

**Data Protocol**

(Write)

1 bit	8 bits	1	8 bits	1	8 bits	1	8 bits	1		8 bits	1	1 bit
Start bit	Slave Addr: D4	Ack	Register offset	Ack	Byte Count=N	Ack	Data Byte 0	Ack	...	Data Byte N-1	Ack	Stop bit

(Read)

1 bit	8 bits	1	8 bits	1	1	8 bits	1	8 bits	1	8 bits	1		8 bits	1	1 bit
Start bit	Slave Addr: D4	Ack	Register offset	Ack	Repeat start	Slave Addr: D5	Ack	Byte Count=N	Ack	Data Byte 0	Ack	...	Data Byte N-1	NOT Ack	Stop bit

**Note:**

1. Register offset for indicating the starting register for indexed block write and indexed block read. Byte Count in write mode cannot be 0.

**Data Byte 0: Control Register**

Bit	Name	Control function	Type	0	1	PWD
7	SMB_EN	SMBus enable	RW	Controlled by SMBus registers	Controlled by device pins	1
6	RESERVED		RW			X
5	RESERVED		RW			X
4	RESERVED		RW			X
3	RESERVED		RW			X
2	RESERVED		RW			X
1	PLL_BW_SEL	Select PLL Bandwidth	RW	Low BW	High BW	1
0	PLL Bypass	Select PLL bypass mode	RW	PLL bypass	PLL enabled	1

**Data Byte 1: Control Register**

Bit	Name	Control function	Type	0	1	PWD
7	RESERVED		RW			X
6	RESERVED		RW			X
5	RESERVED		RW			X
4	RESERVED		RW			X
3	RESERVED		RW			X
2	RESERVED		RW			X
1	RESERVED		RW			X
0	RESERVED		RW			X

**Data Byte 2: Control Register**

Bit	Name	Control function	Type	0	1	PWD
7	RESERVED		RW			X
6	RESERVED		RW			X
5	RESERVED		RW			X
4	RESERVED		RW			X
3	RESERVED		RW			X
2	RESERVED		RW			X
1	RESERVED		RW			X
0	RESERVED		RW			X

**Data Byte 3: Control Register**

Bit	Name	Control function	Type	0	1	PWD
7	RevID3	Revision ID	R			0
6	RevID2		R			0
5	RevID1		R			0
4	RevID0		R			0
3	VENID3	Vendor ID	R			0
2	VENID2		R			0
1	VENID1		R			0
0	VENID0		R			0

**Data Byte 4: Control Register**

Bit	Name	Control function	Type	0	1	PWD
7	Devicde ID		R			0
6			R			0
5			R			0
4			R			0
3			R			0
2			R			1
1			R			1
0			R			0

**Data Byte 5: Control Register**

Bit	Name	Control function	Type	0	1	PWD
7	B57	Write to this register will control how many bytes will be read back, default is 06=6 bytes.	RW			0
6	B56		RW			0
5	B55		RW			0
4	B54		RW			0
3	B53		RW			0
2	B52		RW			1
1	B51		RW			1
0	B50		RW			0



**Packaging Mechanical: 20-Pin TSSOP (L)**

VARIATIONS (ALL DIMENSIONS SHOWN IN MM)			
SYMBOLS	MIN.	NOM.	MAX.
A	—	—	1.20
A1	0.05	—	0.15
A2	0.80	—	1.05
b	0.19	—	0.30
C	0.09	—	0.20
D	6.40	6.50	6.60
E1	4.30	4.40	4.50
E	6.40 BSC		
e	0.65 BSC		
L1	1.00 REF		
L	0.45	0.60	0.75
S	0.20	—	—
θ	0°	—	8°

**Notes:**  
 1. Refer JEDEC MO-153F/AC  
 2. Controlling dimensions in millimeters  
 3. Package outline exclusive of mold flash and metal burr

		DATE: 05/03/12
DESCRIPTION: 20-pin, 173mil Wide TSSOP		
PACKAGE CODE: L		
DOCUMENT CONTROL #: PD-1311	REVISION: F	

12-0373

**Ordering Information**

Ordering Code	Package Code	Package Type	Operating Temperature
PI6CEQ20200LE	L	Pb-free & Green, 20-pin 173-mil TSSOP	0°C to 70°C
PI6CEQ20200LEX	L	Pb-free & Green, 20-pin 173-mil TSSOP, Tape & Reel	0°C to 70°C
PI6CEQ20200LIE	L	Pb-free & Green, 20-pin 173-mil TSSOP	-40°C to 85°C
PI6CEQ20200LIEEX	L	Pb-free & Green, 20-pin 173-mil TSSOP, Tape & Reel	-40°C to 85°C

Notes:

1. Thermal characteristics can be found on the company web site at [www.pericom.com/packaging/](http://www.pericom.com/packaging/)
2. E = Pb-free and Green
3. Adding an X suffix = Tape/Reel

## X-ON Electronics

Largest Supplier of Electrical and Electronic Components

*Click to view similar products for [Clock Buffer](#) category:*

*Click to view products by [Diodes Incorporated](#) manufacturer:*

Other Similar products are found below :

[PL133-27GI](#) [9DBV0541AKLF](#) [9DBV0941AKLF](#) [MPC962309EJ-1H](#) [NB3M8304CDG](#) [NB4N121KMNG](#) [NB7VQ58MMNG](#)  
[8T39S11ANLGI](#) [8T73S1802NLGI](#) [9DBV0941AKILF](#) [MC10E111FNG](#) [MK2308S-1HILF](#) [5PB1216NDGK](#) [6V31024NLG](#) [PL133-27GI-R](#)  
[9DBV0941AKILFT](#) [NB3L02FCT2G](#) [NB3L03FCT2G](#) [NB7VQ58MMNHTBG](#) [ZL40203LDG1](#) [ZL40200LDG1](#) [9DMV0141AKILFT](#)  
[ZL40205LDG1](#) [ZL40201LDG1](#) [9DBV0541AKILF](#) [PI49FCT32807QE](#) [552-02SPGGI](#) [9FG1200DF-1LF](#) [MDB1900ZCQY](#) [9ZXL1530DKILF](#)  
[8SLVP1102ANLGI/W](#) [ZL40223LDG1](#) [5PB1203NTGK8](#) [9FG1001BGLF](#) [MDB1900ZBQY](#) [5PB1213NTGK](#) [5PB1214CMGK](#)  
[ZL40202LDG1](#) [8L30205NLGI8](#) [5PB1204CMGK](#) [5PB1214CMGK8](#) [5PB1203NTGK](#) [5PB1206NDGK](#) [PI49FCT20802QE](#) [MAX9317AECJ+](#)  
[SL2305SC-1T](#) [PI6C10810HE](#) [5P1103A517NLGI](#) [9ZX21901DKLF](#) [NB7L1008MNG](#)