

Card Bus Socket Connectors

IC9 Series

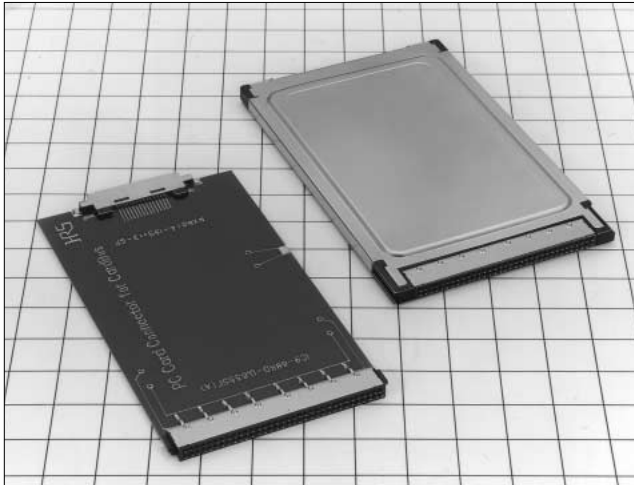

■ Features

1. Compliant with PC Card Standards

Complies with latest requirements of PC Card Standard.

2. Repairable

Repairable terminations of connector solder joints after installation on the board.

3. Lead Offset

Available with two board mounting levels of terminations, to allow use of different height components.

■ Product Specifications

Ratings	Current rating	0.5 A	Operating temperature	-55°C to +85°C (Note 1)	Storage temperature	-10°C to +60°C (Note 2)
	Voltage rating	125 V AC	Operating humidity	95% R.H. or less (No condensation)	Storage humidity	40 to 70% (Note 2)

Item	Specification	Conditions
1. Insulation resistance	1000M ohms min.	500 V DC
2. Withstanding voltage	No flashover or insulation breakdown.	500 V AC / 1 minute
3. Contact resistance	40 mΩ max. (initial value)	1 mA
4. Vibration	No electrical discontinuity of 100ns or more	Frequency: 10 to 2000 Hz, single amplitude of 0.75 mm or acceleration of 147 m/s ² (peak), 4 hours in each of the 3 directions.
5. Humidity (Steady state)	Insulation resistance: 100 MΩ min.	96 hours at temperature of 40°C and humidity of 90% to 95%
6. Temperature cycle	No damage, cracks, or parts looseness.	-55°C, 30 min → 15 to 30°C, within 5 min → 85°C 30 min → 15 to 35°C, within 5 min, for 5 cycles
7. Durability (Insertion/withdrawal)	Change of contact resistance from the start should be 20 mΩ max.	10000 cycles at 400 to 600 cycles per hour
8. Resistance to soldering heat	No deformation of components affecting performance.	Reflow: At the recommended temperature profile
		Manual soldering: 300°C for 3 seconds

Note 1: Includes temperature rise caused by current flow.

Note 2: The term "storage" refers to products stored for long period of time prior to mounting and use. Operating Temperature Range and Humidity range covers non- conducting condition of installed connectors in storage, shipment or during transportation.

■ Materials

Part	Material	Finish	Notes
Insulator	PA	Black	UL94V-0
Contact	Phosphor bronze	Contact Area : gold plating Lead Area : solder plating	—
Ground plate	Brass	Contact Area : gold plating Lead Area : solder plating	—

■ Ordering Information

IC9 - 68 R D - 0.635 SFA

① ② ③ ④ ⑤ ⑥

①	Series name : IC9
②	Number of contacts : 68
③	R : card connector
④	D : 2-row alignment
⑤	Lead pitch : 0.635 mm
⑥	Offset type SF : 0.3 mm offset SFA : 0.9 mm offset

◆ Lead Offset

● Type with 0.3 mm offset

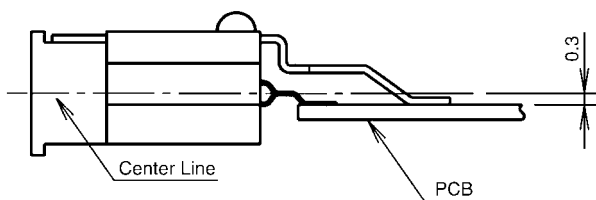

● Type with 0.9 mm offset

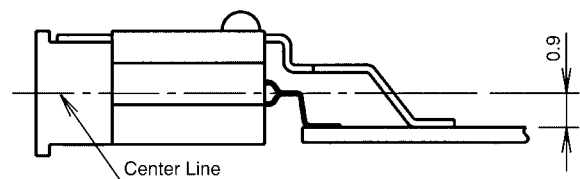

◆ Mounting Method

1. Place and solder the connector without the ground plate as shown in fig.(a).
2. Place the ground plate over the connector as shown in Fig.(b), making sure that the locking tabs are correctly aligned with the slots on both sides of the insulator. Press firmly at both ends to assure secure lock.
Note: Care should be taken that the termination leads of the ground plate are not deformed or damaged during this operation.
3. Solder the termination leads of the ground plate to the board.

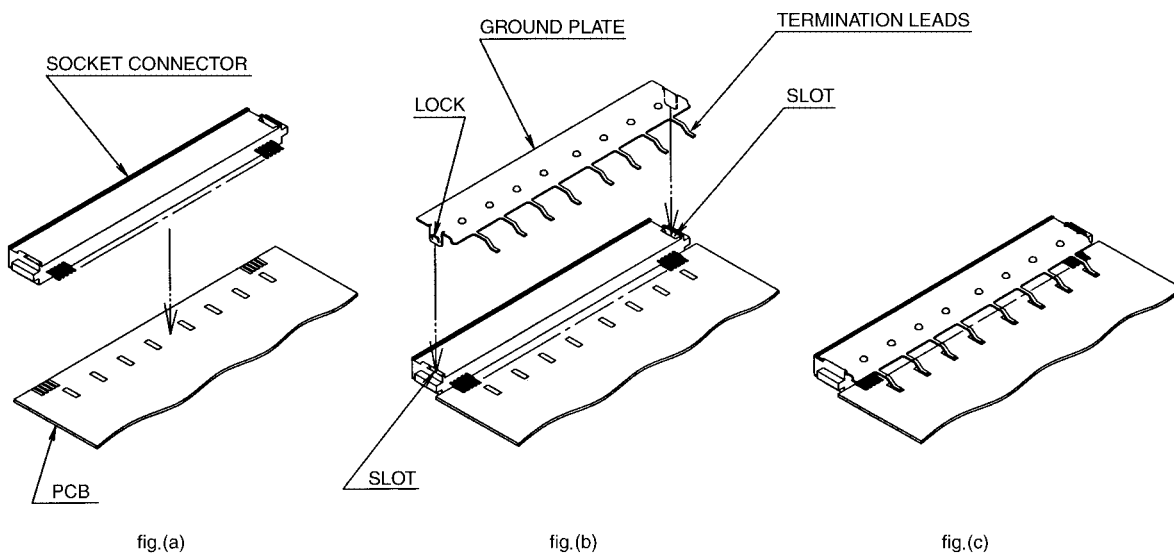

■ Card Connectors

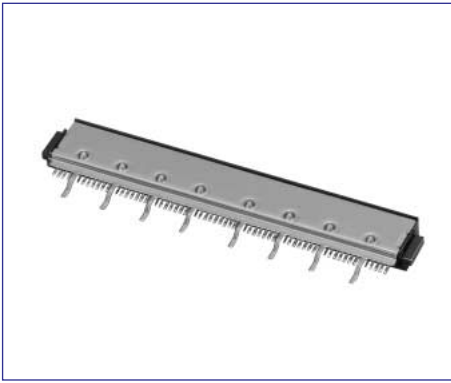

Part Number	CL No.	A
IC9-68RD-0.635SF	640-0901-2	0.3
IC9-68RD-0.635SFA	640-0902-5	0.9

Socket Connector

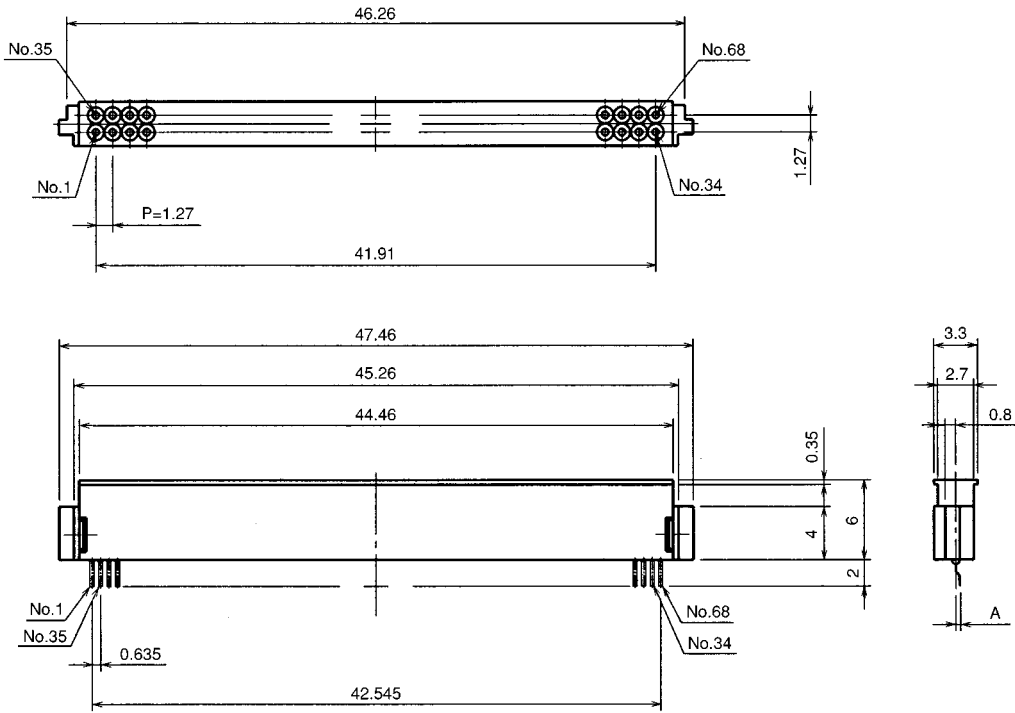

Ground Plate

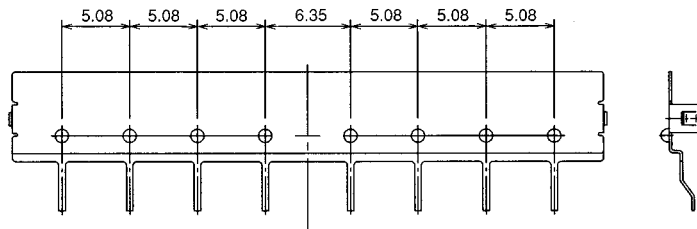

Combined Condition

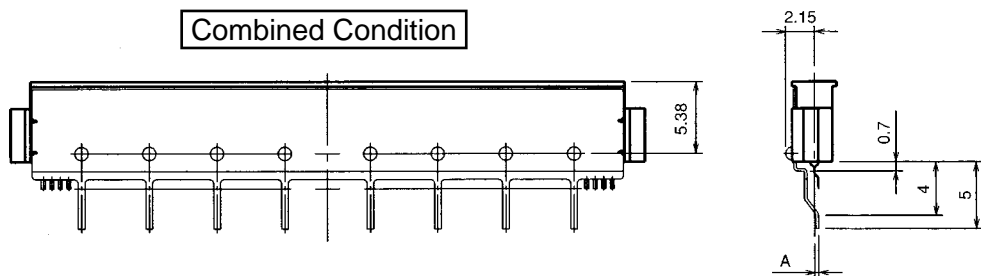

◆PCB mounting pattern

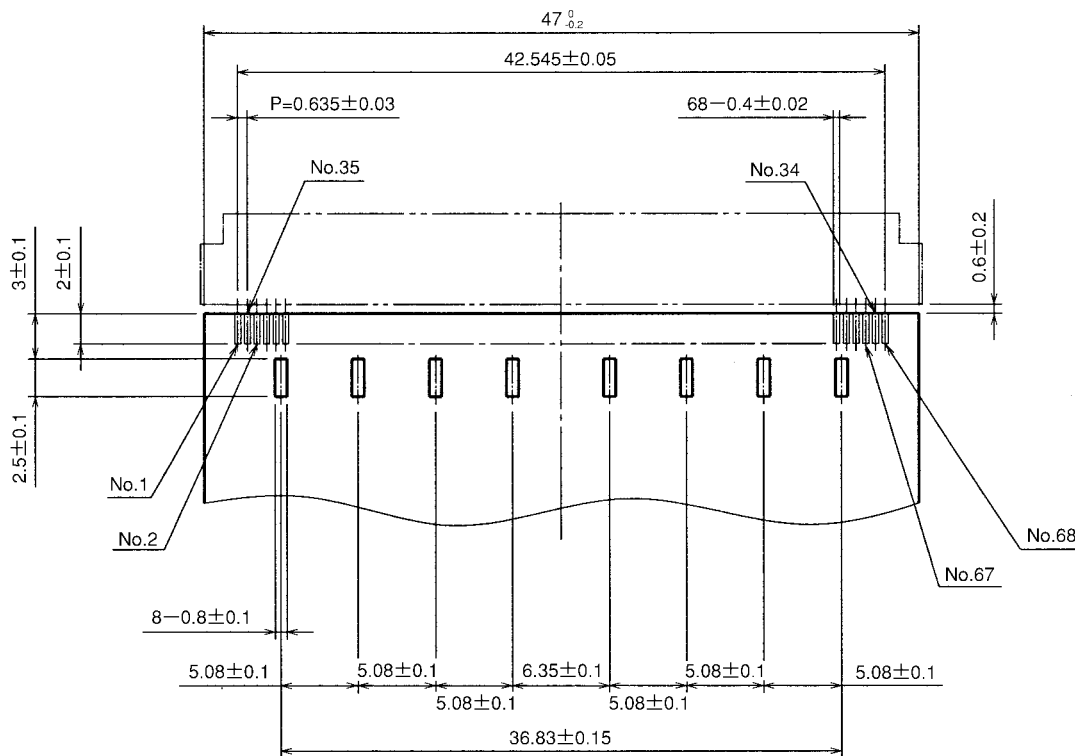

● Recommended board thickness 0.4 to 0.5mm

◆Temperature Profile

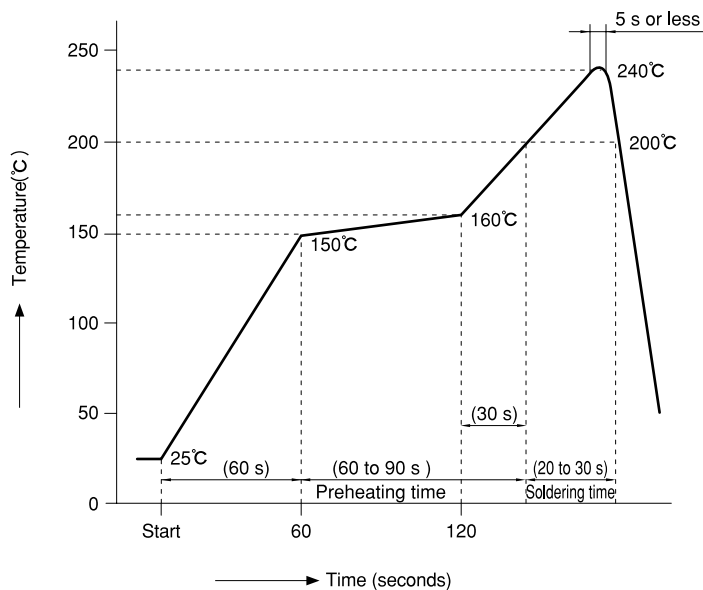

Applicable Conditions

Reflow system : IR reflow

Solder : Paste type 63 Sn/37 Pb
(Flux content 9 wt%)

Test board Glass epoxy 60mm x 60mm x 1.6 mm

Metal mask thickness: 0.15 mm

Recommended temperature profile.

The temperature may be slightly changed according to the solder paste type and amount.

X-ON Electronics

Largest Supplier of Electrical and Electronic Components

Click to view similar products for [Memory Card Connectors](#) category:

Click to view products by [Hirose](#) manufacturer:

Other Similar products are found below :

[M10-597810-355](#) [M21-033321-005](#) [6426-201-21343](#) [69.920.0553.0](#) [MCR60A-98D-2.54DSA\(70\)](#) [FCN-568P068-G/07-4V](#) [809180410000000](#)
[95622-003LF](#) [DM3AT-SF-PEJM5\(41\)](#) [EN2997S72039F6](#) [N7E50-7516PG-20-WF](#) [IC11S-BUR-PNEJL\(71\)](#) [NX30TA-15PAA\(50\)](#) [21920-5](#)
[2041353-2](#) [FUA006-3220-0](#) [33CFAE-DN](#) [MI21A-50PD-SF-EJR\(91\)](#) [502431-1011](#) [5175651-2](#) [10-247926-166](#) [EN2997S02039B8](#)
[EN2997S61212BN](#) [EN2997S72039B6](#) [EN2997SE02039B8](#) [EN2997SE61212BN](#) [EN2997SE72039B6](#) [71-252718-32P](#) [NX1-32T-KT3K\(05\)](#)
[95622-003LF](#) [91-570124-15P](#) [192900-0488](#) [DM1AA-SF-PEJ](#) [95079-00CALF](#) [84648-056HLF](#) [68-580163-21S](#) [33DVIR-29S12R](#)
[SF58S006VBRR2000](#) [93-570123-08P](#) [GMC020080HR](#) [125A-78C00](#) [1010040575#](#) [MI20A-50PD-SF-EJL\(71\)](#) [KP10S-SF-PEJ\(812\)](#)
[DM1AA-SF-PEJ\(31\)](#) [FO-10GGBLCX20-002](#) [504536-0691](#) [115S-ACA2](#) [115S-ACA3](#) [115S-BS00](#)