

EP1100HSTSC-13.560M

[Click part number to visit Part Number Details page](#)

REGULATORY COMPLIANCE (Data Sheet downloaded on Dec 6, 2018)



◀ Click badges to download compliance docs

Regulatory Compliance standards are subject to updates by governing bodies. Click the badges to download the latest compliance docs for this part number directly from Ecliptek.



ITEM DESCRIPTION

Quartz Crystal Clock Oscillators XO (SPXO) HCMOS/TTL (CMOS) 5.0Vdc 8 Pin DIP Metal Thru-Hole 13.560MHz ±100ppm -20°C to +70°C

ELECTRICAL SPECIFICATIONS

Nominal Frequency	13.560MHz
Frequency Tolerance/Stability	±100ppm Maximum (Inclusive of all conditions: Calibration Tolerance at 25°C, Frequency Stability over the Operating Temperature Range, Supply Voltage Change, Output Load Change, First Year Aging at 25°C, Shock, and Vibration)
Aging at 25°C	±5ppm/year Maximum
Operating Temperature Range	-20°C to +70°C
Supply Voltage	5.0Vdc ±10%
Input Current	45mA Maximum (Unloaded)
Output Voltage Logic High (Voh)	Vdd-0.4Vdc Minimum (IOH=-16mA)
Output Voltage Logic Low (Vol)	0.4Vdc Maximum (IOL=+16mA)
Rise/Fall Time	4nSec Maximum (Measured at 20% to 80% of waveform)
Duty Cycle	50 ±10(%) (Measured at 1.4Vdc with TTL Load; Measured at 50% of waveform with HCMOS Load)
Load Drive Capability	50pF HCMOS Load Maximum
Output Logic Type	CMOS
Pin 1 Connection	Tri-State (Disabled Output: High Impedance)
Pin 1 Input Voltage (Vih and Vil)	+2.0Vdc Minimum to enable output, +0.8Vdc Maximum to disable output, No Connect to enable output.
Disable Current	30mA Maximum (Pin 1 = Ground)
Standby Current	50µA Maximum (Pin 1 = Ground)
Peak to Peak Jitter (tPK)	100pSec Maximum, 50pSec Typical
RMS Period Jitter (tRMS)	13pSec Maximum, 8pSec Typical
Start Up Time	10mSec Maximum
Storage Temperature Range	-55°C to +125°C

ENVIRONMENTAL & MECHANICAL SPECIFICATIONS

Fine Leak Test	MIL-STD-883, Method 1014, Condition A
Gross Leak Test	MIL-STD-883, Method 1014, Condition C
Lead Integrity	MIL-STD-883, Method 2004
Mechanical Shock	MIL-STD-202, Method 213, Condition C
Resistance to Soldering Heat	MIL-STD-202, Method 210
Resistance to Solvents	MIL-STD-202, Method 215
Solderability	MIL-STD-883, Method 2003
Temperature Cycling	MIL-STD-883, Method 1010
Vibration	MIL-STD-883, Method 2007, Condition A

EP1100HSTSC-13.560M

[Click part number to visit Part Number Details page](#)

MECHANICAL DIMENSIONS (all dimensions in millimeters)

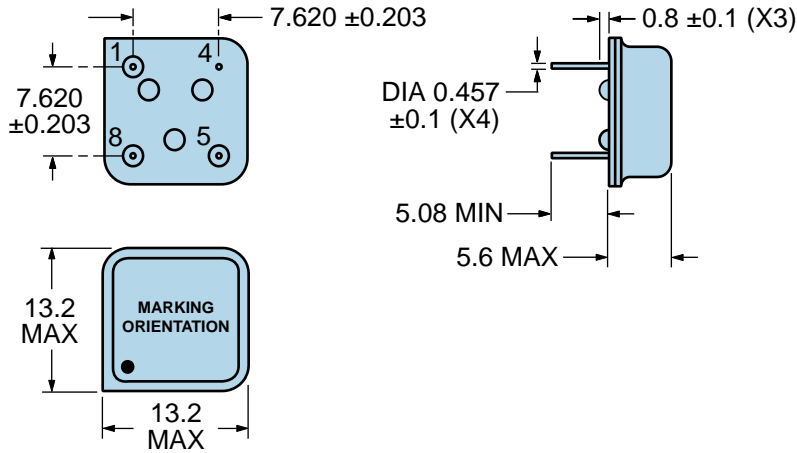

PIN	CONNECTION
1	Tri-State (High Impedance)
4	Case/Ground
5	Output
8	Supply Voltage

LINE	MARKING
1	ECLIPTEK
2	EP11TS <i>EP11=Product Series</i>
3	13.560M
4	XXYZZ <i>XX=Ecliptek Manufacturing Code</i> <i>Y=Last Digit of the Year</i> <i>ZZ=Week of the Year</i>

EP1100HSTSC-13.560M [Click part number to visit Part Number Details page](#)

OUTPUT WAVEFORM & TIMING DIAGRAM

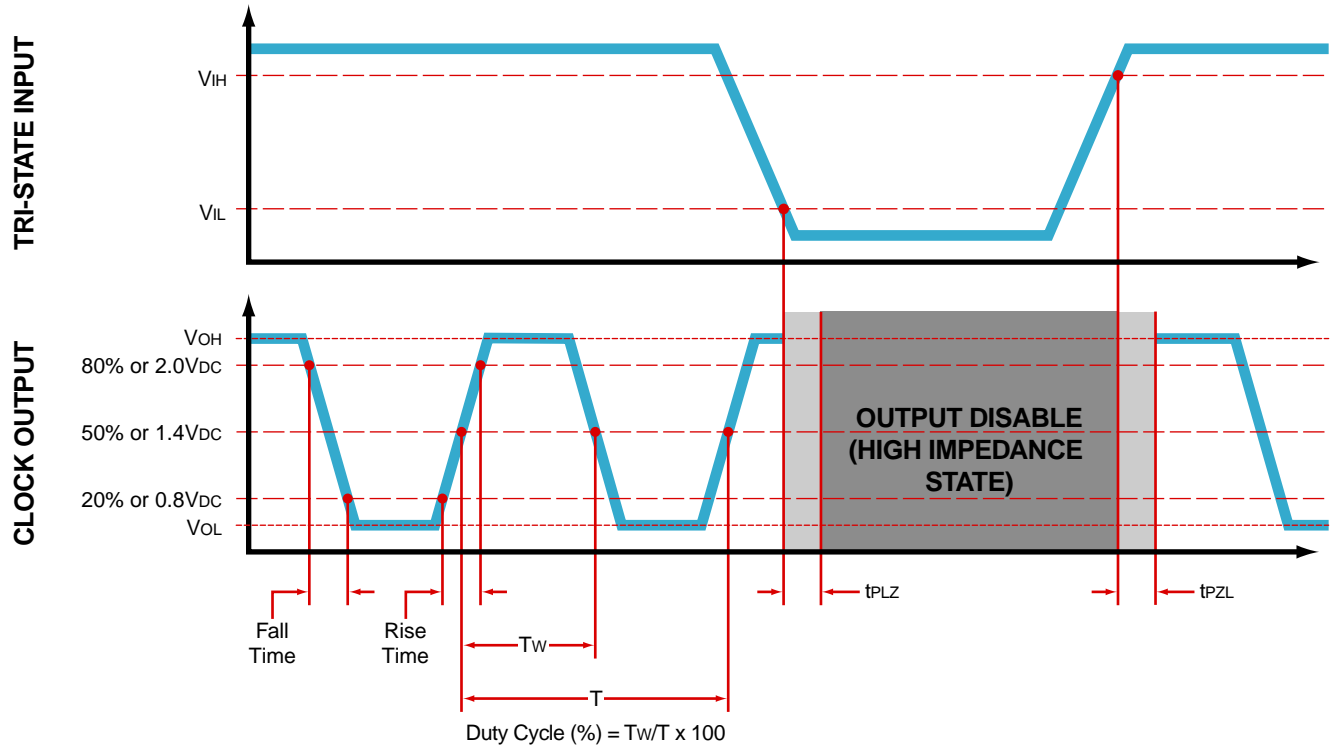

EP1100HSTSC-13.560M

[Click part number to visit Part Number Details page](#)

Test Circuit for TTL Output

Output Load Drive Capability	R_L Value (Ohms)	C_L Value (pF)
10TTL	390	15
5TTL	780	15
2TTL	1100	6
10LSTTL	2000	15
1TTL	2200	3

Table 1: R_L Resistance Value and C_L Capacitance Value Vs. Output Load Drive Capability

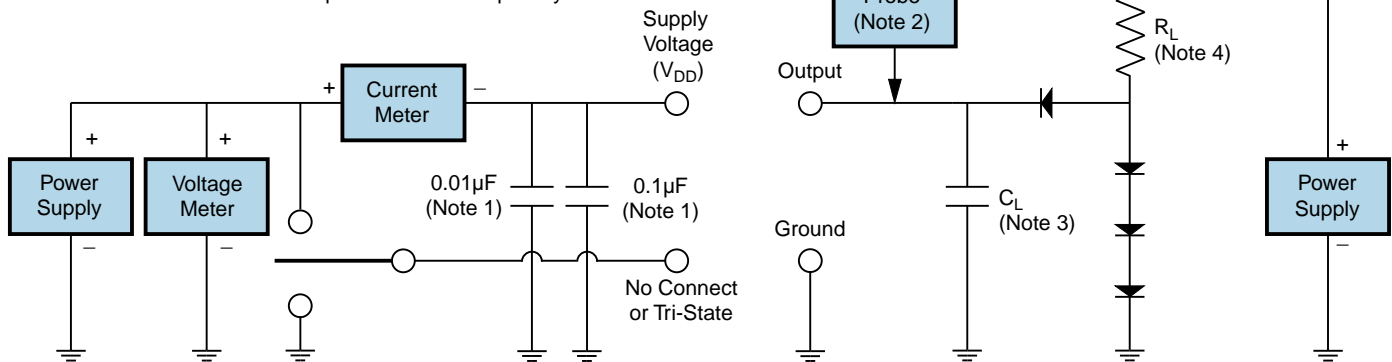

Note 1: An external $0.1\mu\text{F}$ low frequency tantalum bypass capacitor in parallel with a $0.01\mu\text{F}$ high frequency ceramic bypass capacitor close to the package ground and V_{DD} pin is required.

Note 2: A low capacitance ($<12\text{pF}$), 10X attenuation factor, high impedance ($>10\text{Mohms}$), and high bandwidth ($>300\text{MHz}$) passive probe is recommended.

Note 3: Capacitance value C_L includes sum of all probe and fixture capacitance.

Note 4: Resistance value R_L is shown in Table 1. See applicable specification sheet for 'Load Drive Capability'.

Note 5: All diodes are MMBD7000, MMBD914, or equivalent.

EP1100HSTSC-13.560M

[Click part number to visit Part Number Details page](#)

Test Circuit for CMOS Output

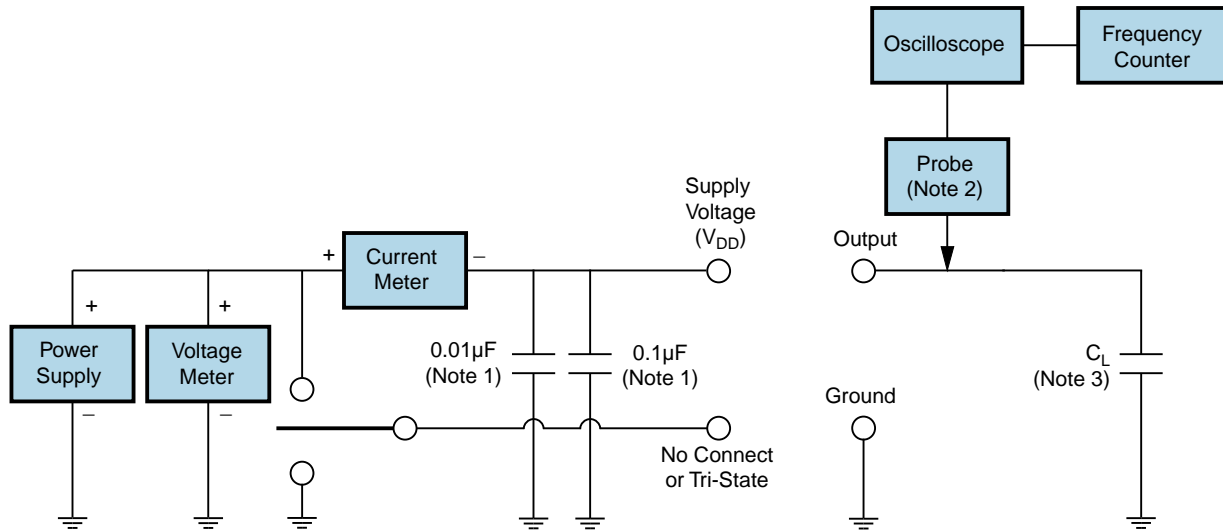

Note 1: An external $0.1\mu\text{F}$ low frequency tantalum bypass capacitor in parallel with a $0.01\mu\text{F}$ high frequency ceramic bypass capacitor close to the package ground and V_{DD} pin is required.

Note 2: A low capacitance ($<12\text{pF}$), 10X attenuation factor, high impedance ($>10\text{Mohms}$), and high bandwidth ($>300\text{MHz}$) passive probe is recommended.

Note 3: Capacitance value C_L includes sum of all probe and fixture capacitance.

EP1100HSTSC-13.560M

[Click part number to visit Part Number Details page](#)

Recommended Solder Reflow Methods



High Temperature Solder Bath (Wave Solder)

$T_s \text{ MAX}$ to T_L (Ramp-up Rate)	3°C/Second Maximum
---	--------------------

Preheat

- Temperature Minimum ($T_s \text{ MIN}$)	150°C
- Temperature Typical ($T_s \text{ TYP}$)	175°C
- Temperature Maximum ($T_s \text{ MAX}$)	200°C
- Time ($t_s \text{ MIN}$)	60 - 180 Seconds

Ramp-up Rate (T_L to T_P)	3°C/Second Maximum
---------------------------------	--------------------

Time Maintained Above:

- Temperature (T_L)	217°C
- Time (t_L)	60 - 150 Seconds

Peak Temperature (T_P)	260°C Maximum for 10 Seconds Maximum
----------------------------	--------------------------------------

Target Peak Temperature ($T_P \text{ Target}$)	250°C +0/-5°C
--	---------------

Time within 5°C of actual peak (t_p)	20 - 40 Seconds
--	-----------------

Ramp-down Rate	6°C/Second Maximum
----------------	--------------------

Time 25°C to Peak Temperature (t)	8 Minutes Maximum
-----------------------------------	-------------------

Moisture Sensitivity Level	Level 1
----------------------------	---------

EP1100HSTSC-13.560M

[Click part number to visit Part Number Details page](#)

Recommended Solder Reflow Methods

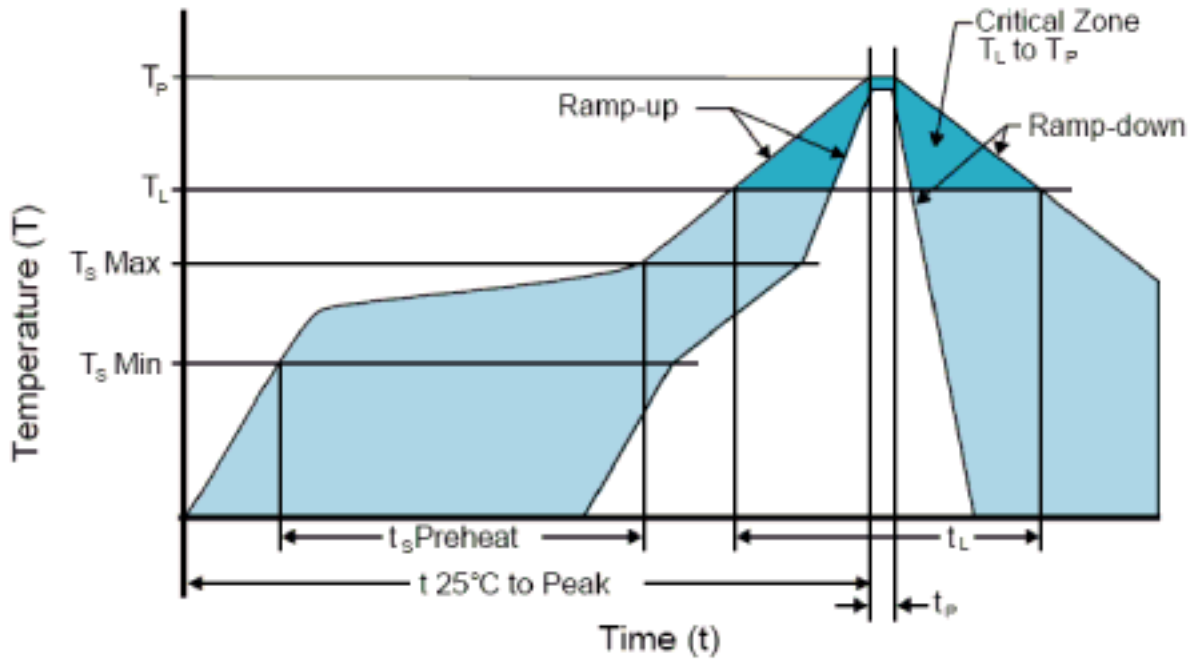

Low Temperature Infrared/Convection 185°C

T_s MAX to T_L (Ramp-up Rate)	5°C/Second Maximum
--	--------------------

Preheat

- Temperature Minimum (T_s MIN)	N/A
- Temperature Typical (T_s TYP)	150°C
- Temperature Maximum (T_s MAX)	N/A
- Time (t_s MIN)	60 - 120 Seconds

Ramp-up Rate (T_L to T_P)	5°C/Second Maximum
--	--------------------

Time Maintained Above:

- Temperature (T_L)	150°C
- Time (t_L)	200 Seconds Maximum

Peak Temperature (T_P)	185°C Maximum
--	---------------

Target Peak Temperature (T_P Target)	185°C Maximum 2 Times
--	-----------------------

Time within 5°C of actual peak (t_p)	10 Seconds Maximum 2 Times
--	----------------------------

Ramp-down Rate	5°C/Second Maximum
-----------------------	--------------------

Time 25°C to Peak Temperature (t)	N/A
--	-----

Moisture Sensitivity Level	Level 1
-----------------------------------	---------

EP1100HSTSC-13.560M

[Click part number to visit Part Number Details page](#)

Recommended Solder Reflow Methods

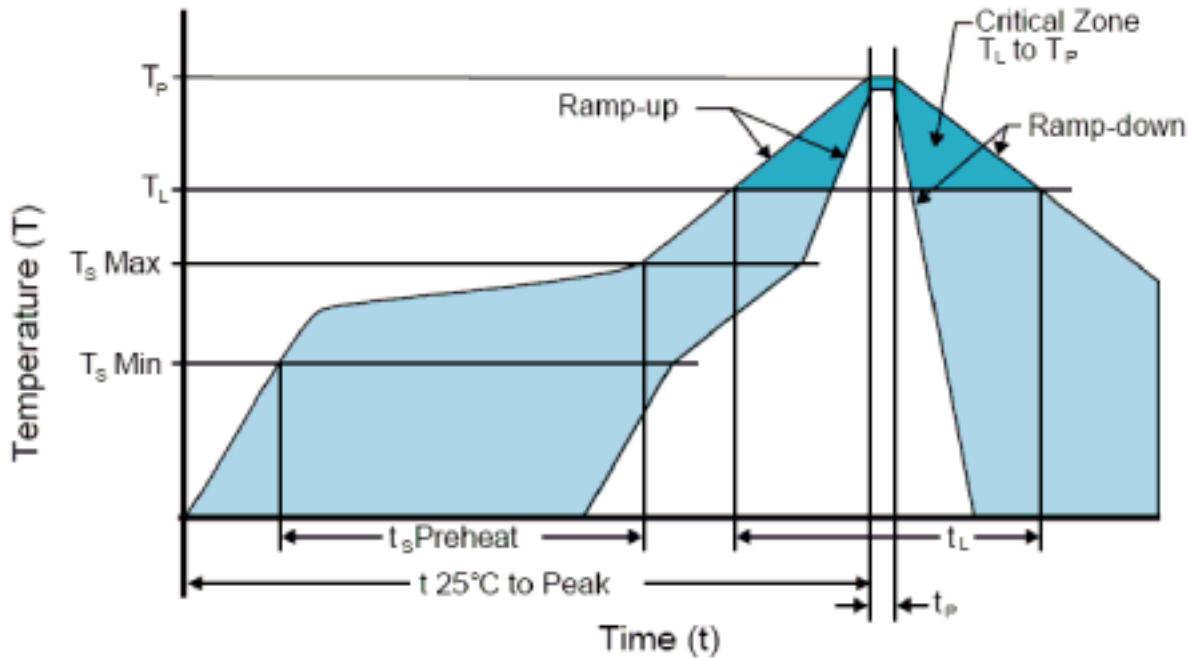

Low Temperature Solder Bath (Wave Solder)

T_s MAX to T_L (Ramp-up Rate)	$5^\circ\text{C}/\text{Second}$ Maximum
Preheat	
- Temperature Minimum (T_s MIN)	N/A
- Temperature Typical (T_s TYP)	150°C
- Temperature Maximum (T_s MAX)	N/A
- Time (t_s MIN)	30 - 60 Seconds
Ramp-up Rate (T_L to T_P)	$5^\circ\text{C}/\text{Second}$ Maximum
Time Maintained Above:	
- Temperature (T_L)	150°C
- Time (t_L)	200 Seconds Maximum
Peak Temperature (T_P)	245°C Maximum
Target Peak Temperature (T_P Target)	245°C Maximum 1 Time / 235°C Maximum 2 Times
Time within 5°C of actual peak (t_p)	5 Seconds Maximum 1 Time / 15 Seconds Maximum 2 Times
Ramp-down Rate	$5^\circ\text{C}/\text{Second}$ Maximum
Time 25°C to Peak Temperature (t)	N/A
Moisture Sensitivity Level	Level 1

Low Temperature Manual Soldering

185°C Maximum for 10 Seconds Maximum, 2 times Maximum.

High Temperature Manual Soldering

260°C Maximum for 5 Seconds Maximum, 2 times Maximum.

X-ON Electronics

Largest Supplier of Electrical and Electronic Components

Click to view similar products for [Standard Clock Oscillators](#) category:

Click to view products by [Ecliptek](#) manufacturer:

Other Similar products are found below :

[EP1400SJTSC-125.000M](#) [601137](#) [601252](#) [CSX750FBC-24.000M-UT](#) [CSX750FBC-33.333M-UT](#) [CSX750FCC-3.6864M-UT](#) [F335-12](#) [F335-25](#) [DSC506-03FM2](#) [ASA-20.000MHZ-L-T](#) [ASA-25.000MHZ-L-T](#) [ASA-27.000MHZ-L-T](#) [ASV-20.000MHZ-LR-T](#) [ECS-2018-160-BN-TR](#) [EL13C7-H2F-125.00M](#) [MXO45HS-2C-66.6666MHZ](#) [SiT1602BI-22-33E-50.000000E](#) [SIT8003AC-11-33S-2.04800X](#) [SiT8256AC-23-33E-156.250000X](#) [SIT8918AA-11-33S-50.000000G](#) [SM4420TEV-40.0M-T1K](#) [F335-24](#) [F335-40](#) [F335-50](#) [F535L-10](#) [F535L-12](#) [F535L-16](#) [F535L-27](#) [F535L-48](#) [PE7744DW-100.0M](#) [CSX750FBC-20.000M-UT](#) [CSX-750FBC33333000T](#) [CSX750FBC-4.000M-UT](#) [CSX750FBC-7.3728M-UT](#) [CSX750FBC-8.000M-UT](#) [CSX-750FCC14745600T](#) [CSX750FCC-16.000M-UT](#) [CSX-750FCC40000000T](#) [CSX750FCC-4.000M-UT](#) [ASA-22.000MHZ-L-T](#) [ASA2-26.000MHZ-L-T](#) [ASA-40.000MHZ-L-T](#) [ASA-48.000MHZ-L-T](#) [ASA-60.000MHZ-L-T](#) [ASF1-3.686MHZ-N-K-S](#) [XO37CTECNA10M](#) [XO57CRECNA16M](#) [XO57CTECNA3M6864](#) [XO57CTECNA4M9152](#) [DSC400-0333Q0032KE1-EVB](#)