

REVISIONS				
P.	LTN	DESCRIPTION	DATE	APVD
A8		REVISED PER ECO-15-003872	25MAR2015	DD DS
A9		REVISED PER ECO-16-003526	09MAR2016	JM DS

- 1 ACCEPTS #3 SELF TAPPING THREAD FORMING SCREWS OR METRIC EQUIVALENT. DRIVE TO 0.6-0.8 N-m
- 2 DATE CODE IN THIS LOCATION USING 5 DIGIT CODE  
FIRST 2 DIGITS = YEAR, SECOND 2 DIGITS = WEEK  
LAST DIGIT = DAY.
- 3 MATERIALS: HEADER HOUSING - GLASS FILLED PBT  
PINS - TIN OR GOLD PLATED BRASS
- 4 HOUSING COLORS ARE MECHANICALLY KEYED TO MATE ONLY WITH IDENTICALLY COLORED PLUG ASSEMBLIES.
- 5. HEADER MATES TO PLUG ASSEMBLY 776164 WHICH USES REELED TERMINAL 770520 OR LOOSE PIECE TERMINAL 770854.

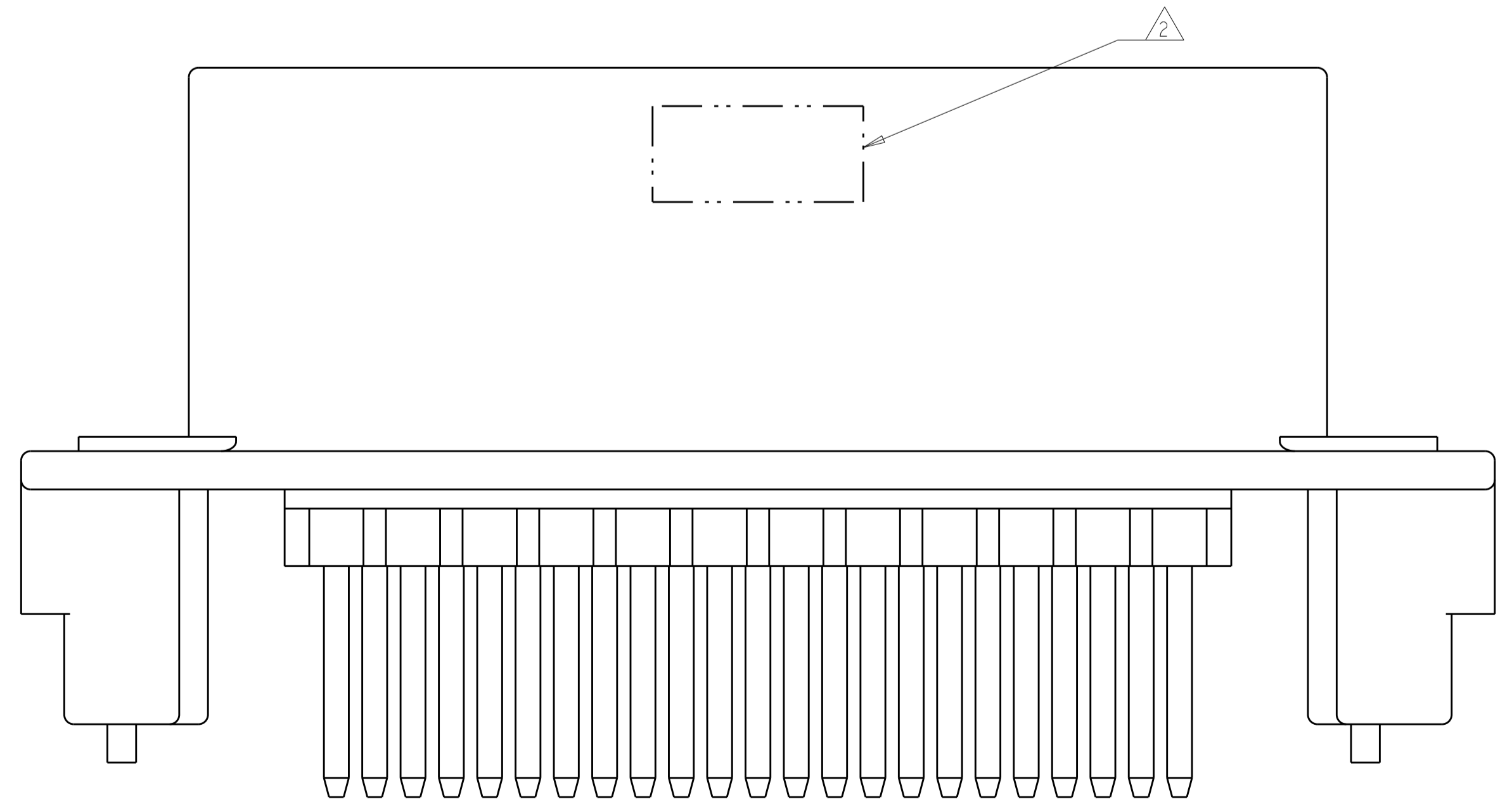
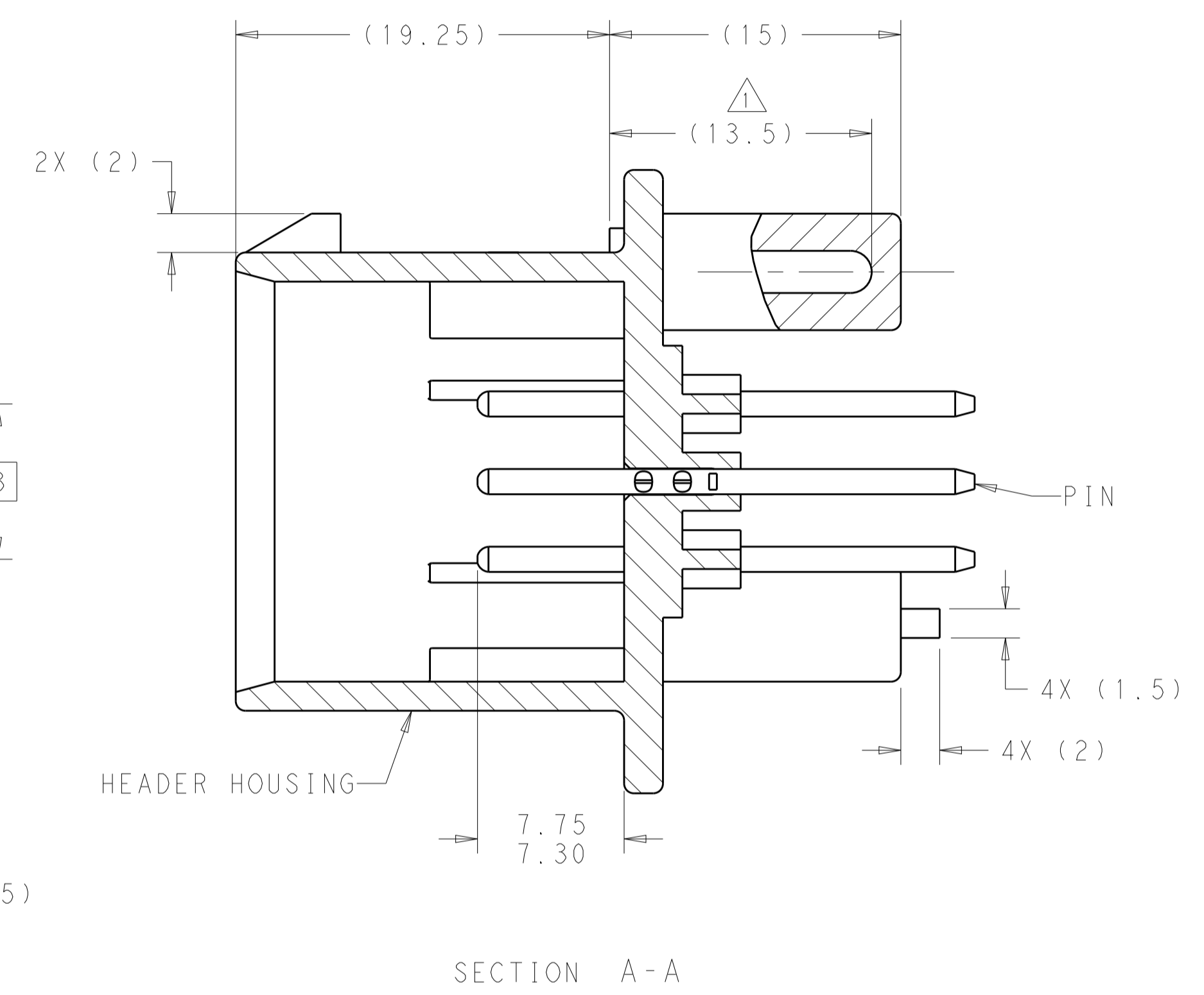
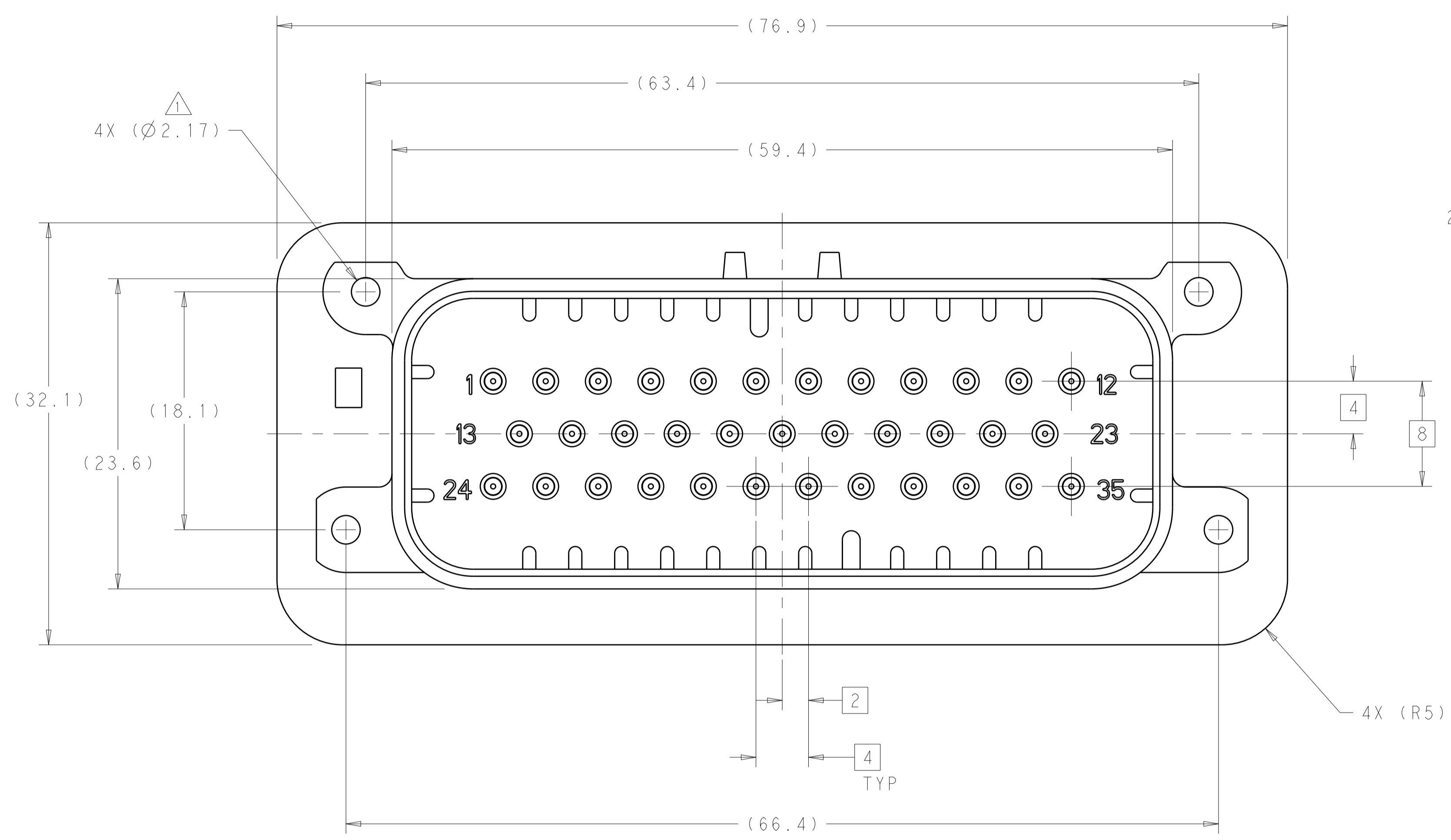

776230-1 & 1-776230-1 SHOWN

ORANGE	DURAGOLD	1-776230-6
BLUE	DURAGOLD	1-776230-5
GRAY	DURAGOLD	1-776230-4
NATURAL	DURAGOLD	1-776230-2
BLACK	DURAGOLD	1-776230-1
BLUE	TIN	776230-5
GRAY	TIN	776230-4
NATURAL	TIN	776230-2
BLACK	TIN	776230-1
HEADER COLOR	PLATING	PART NUMBER

THIS DRAWING IS A CONTROLLED DOCUMENT. DIMENSIONING AND TOLERANCING PER ASME Y14.5M-2009.		OWN: D. STRAUSSER 04FEB2010 CHK: D. STRAUSSER 22MAR2010 APVD: D. STRAUSSER 27APR2010	NAME: ASSEMBLY, HEADER, 35 POSITION, VERTICAL, AMPSEAL	
DIMENSIONS: mm	TOLERANCES UNLESS OTHERWISE SPECIFIED: 0 PLC ±0.2 1 PLC ±0.13 2 PLC ±0.13 3 PLC ±0.13 4 PLC ±0.13 ANGLES ±0.5°	PRODUCT SPEC: 108-1329 APPLICATION SPEC: 114-16016	SIZE: A1 CAGE CODE: 00779 DRAWING NO: 776230	RESTRICTED TO: -
MATERIAL: 3	FINISH: 4	WEIGHT: -	CUSTOMER DRAWING	SCALE: 4:1 SHEET 1 OF 2 REV: A9

REVISIONS				
P.	LTH	DESCRIPTION	DATE	APVD
-	-	SEE SHEET 1	-	-

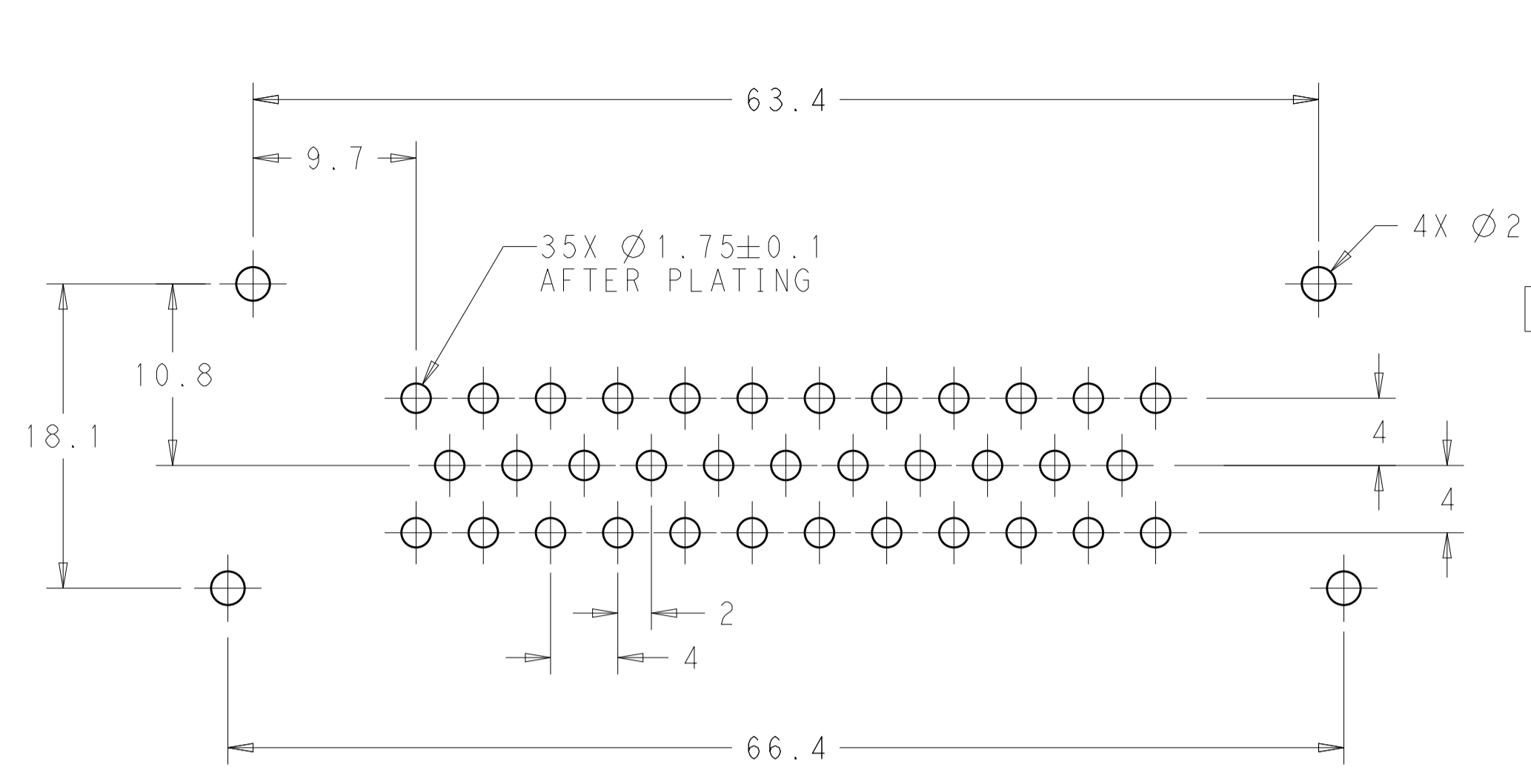

RECOMMENDED P.C. BOARD LAYOUT  
 FOR 1.57 THICK P.C. BOARD

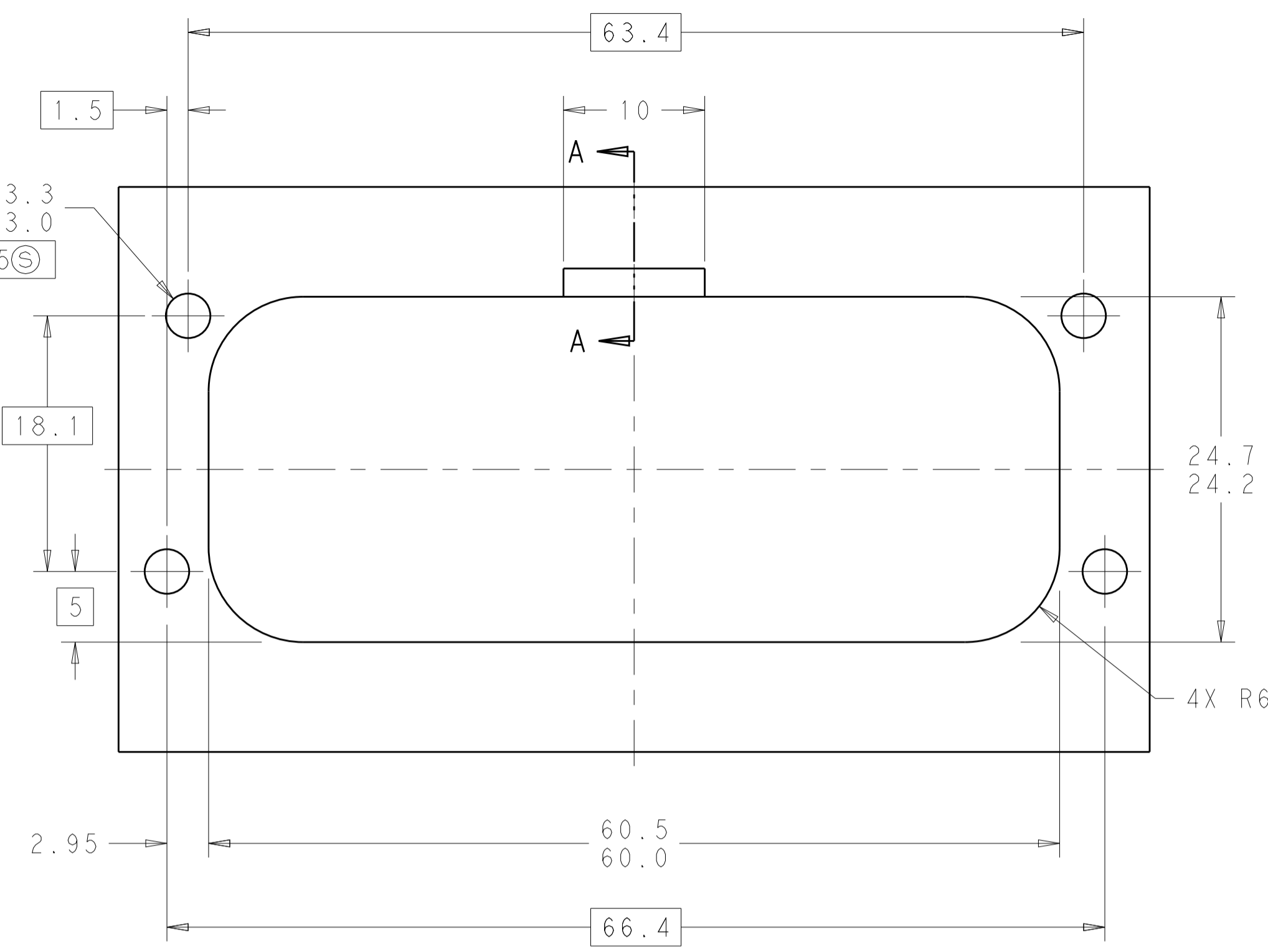

RECOMMENDED MOUNTING HOLE LAYOUT  
 FOR 5.0 MAX THICK PANEL

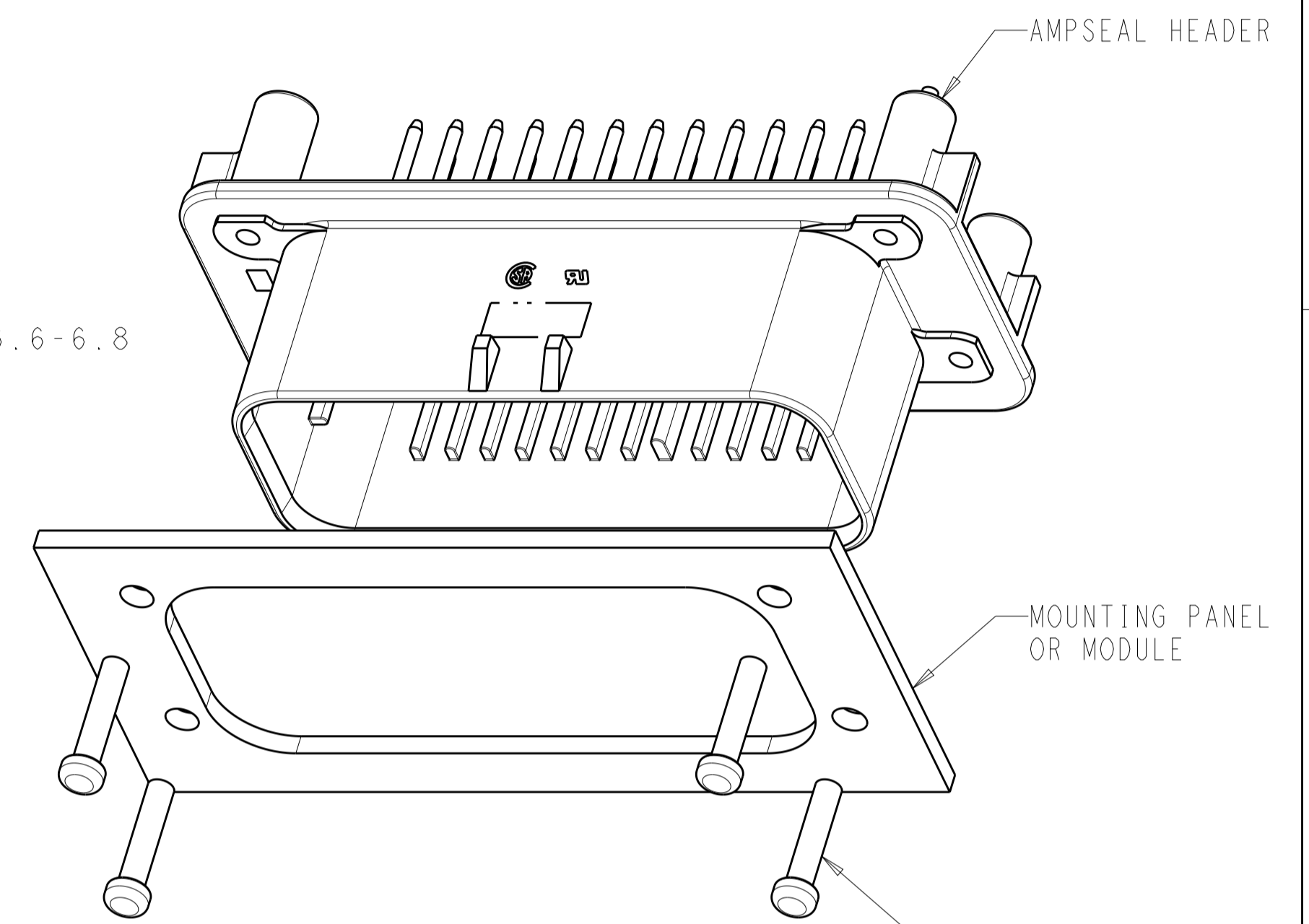

SCALE 2:1

MOUNTING SCREW (4)  
 TORQUE TO 0.6N-m TO 0.8N-m

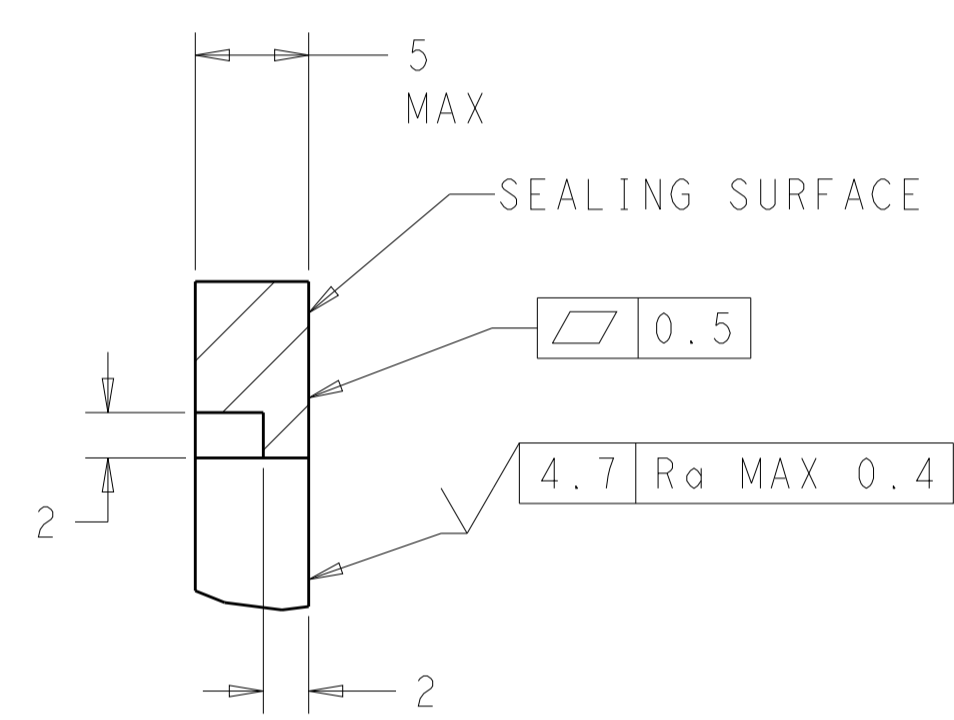

SECTION A-A  
 OPTIONAL CONSTRUCTION IF PANEL  
 THICKNESS IS GREATER THAN 2.0

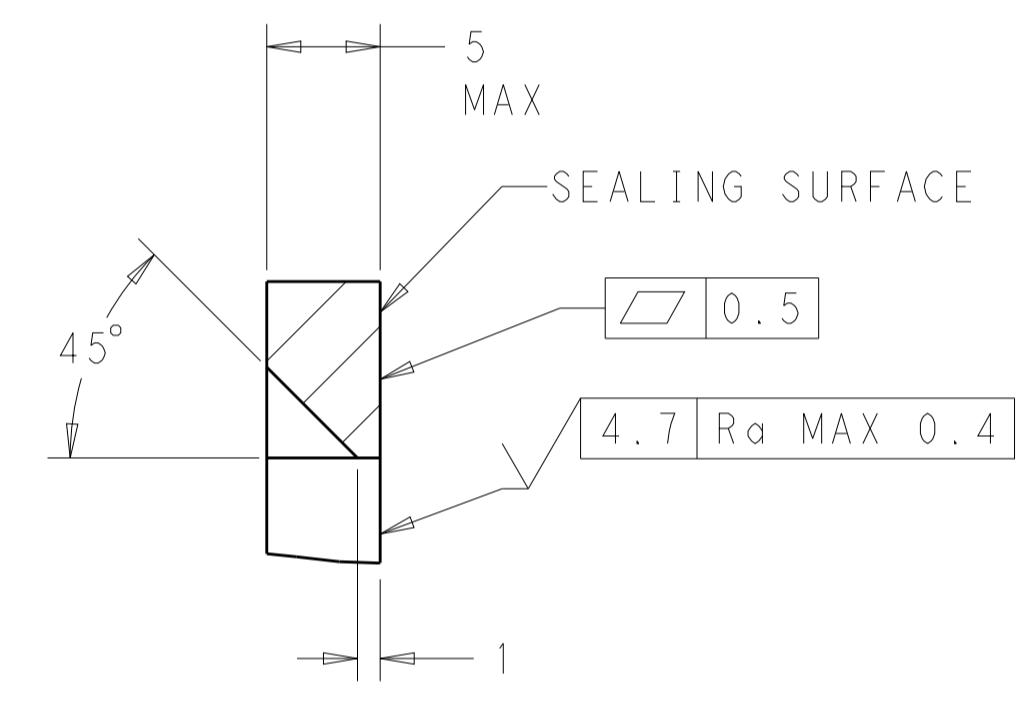

SECTION A-A  
 OPTIONAL CONSTRUCTION IF PANEL  
 THICKNESS IS GREATER THAN 2.0

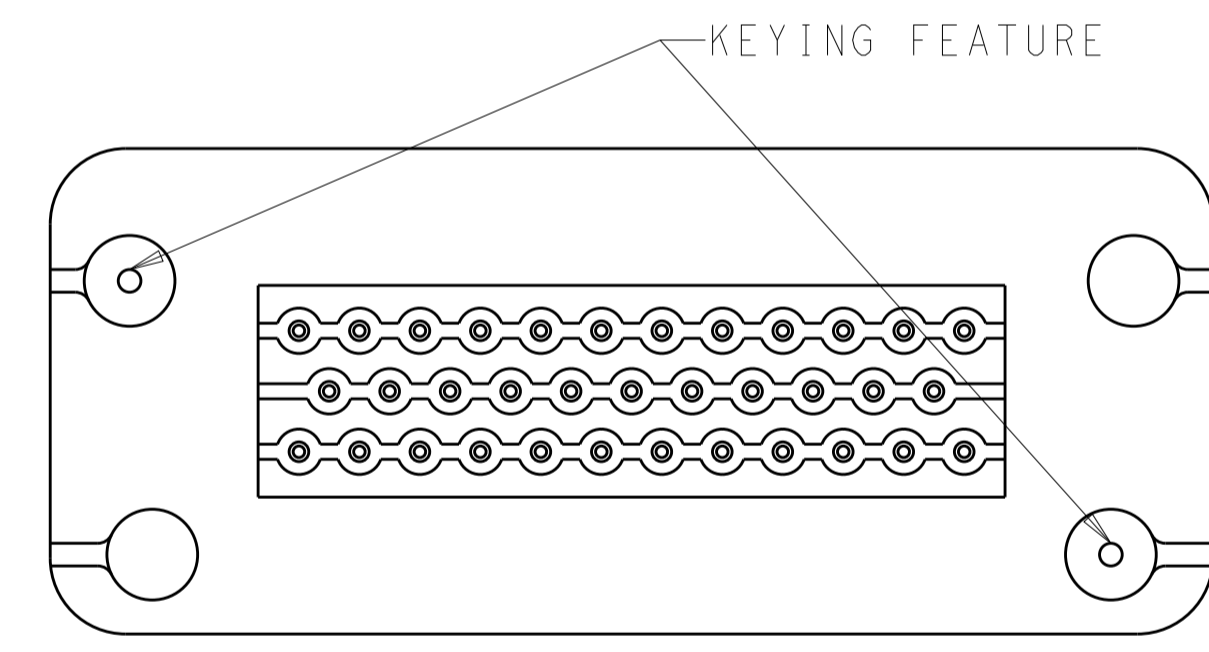

KEYING FOR 776230-1, 1-776230-1, 776230-4,  
 1-776230-4 AND 1-776230-6  
 SCALE 2:1

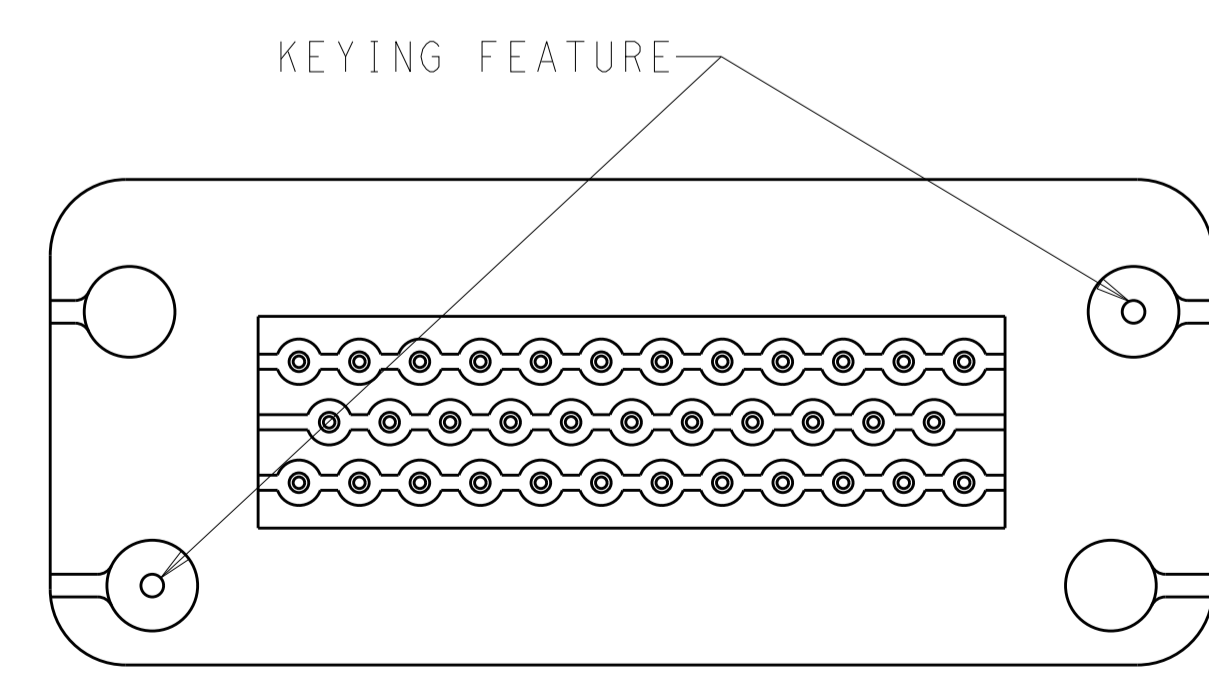

KEYING FOR 776230-2, 1-776230-2, 776230-5  
 AND 1-776230-5  
 SCALE 2:1

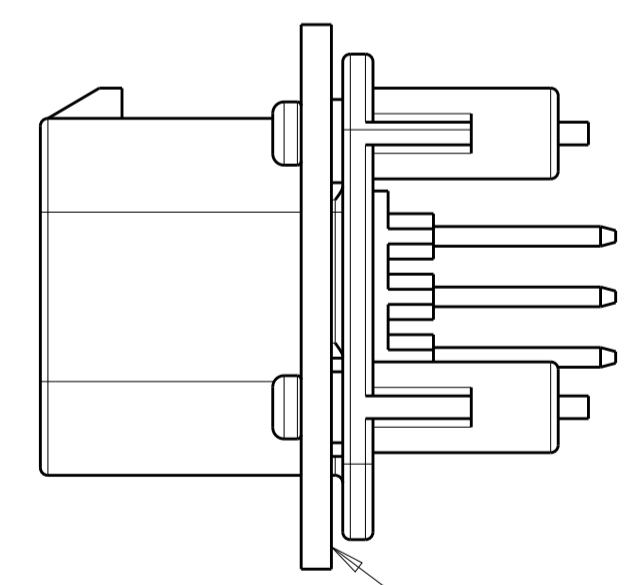

SCALE 2:1

ENSURE THE HEADER IS FLUSH  
 TO THE PANEL FACE ALL AROUND  
 BEFORE TIGHTENING TO FINAL TORQUE

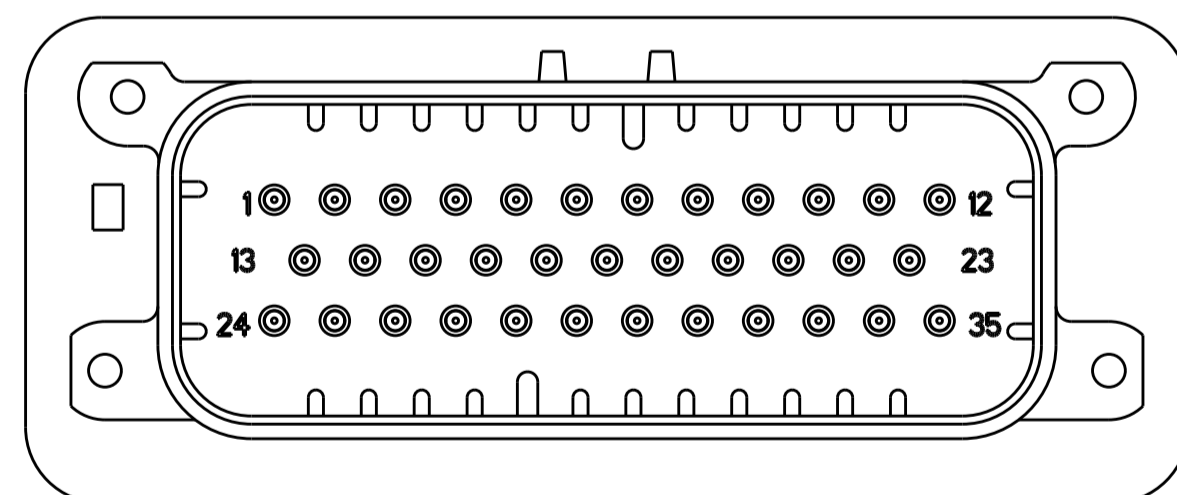

776230-2 & 1-776230-2  
 KEY LOCATION  
 SCALE 2:1

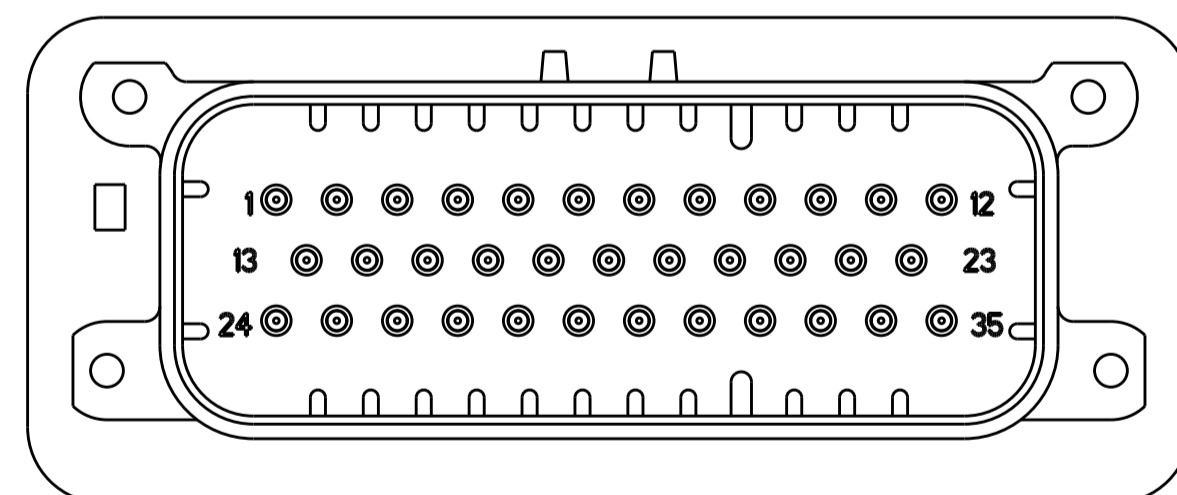

776230-4 & 1-776230-4  
 KEY LOCATION  
 SCALE 2:1

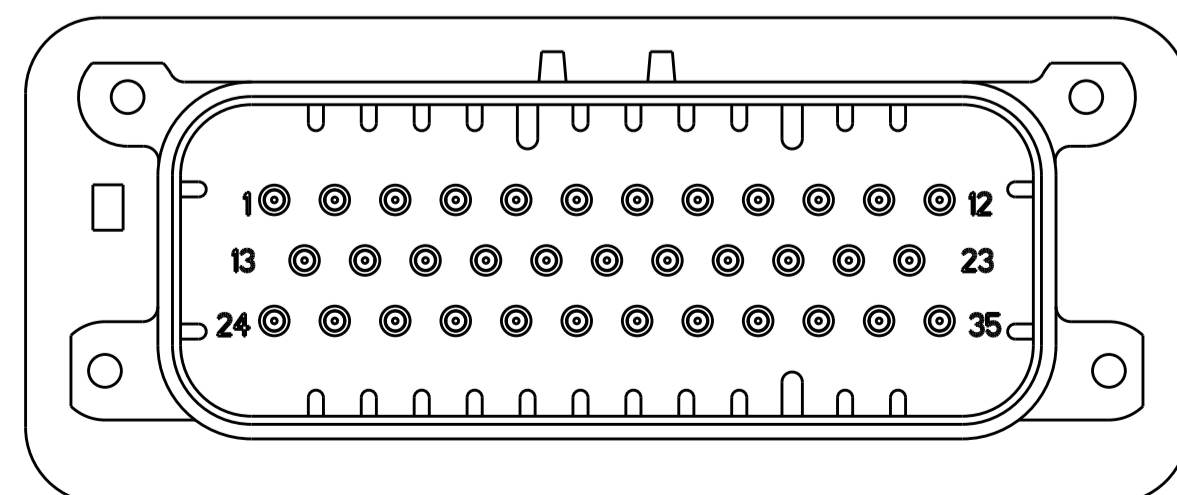

776230-5 & 1-776230-5  
 KEY LOCATION  
 SCALE 2:1

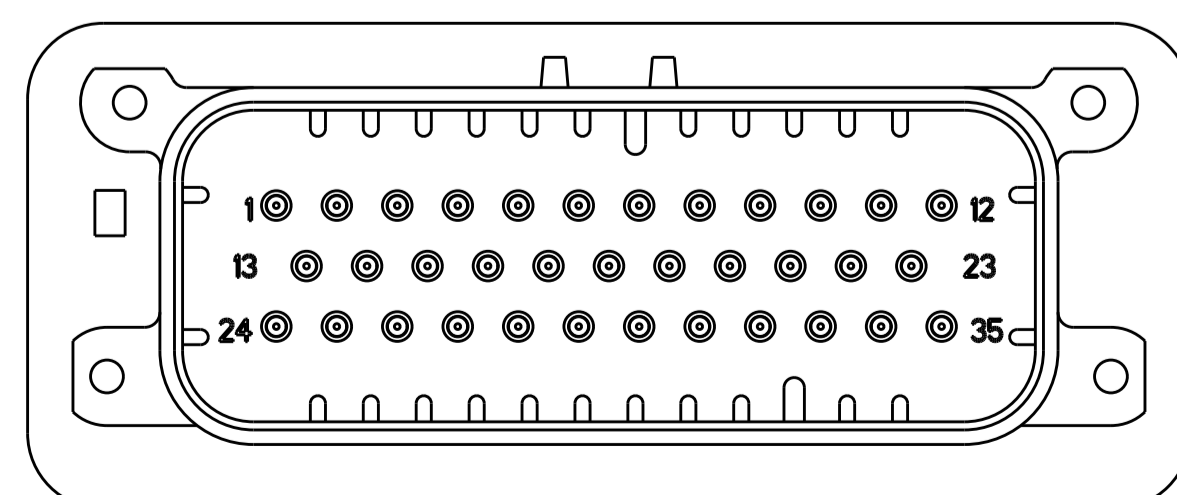

1-776230-6  
 KEY LOCATION  
 SCALE 2:1

THIS DRAWING IS A CONTROLLED DOCUMENT.		OWN: D. STRAUSSER 04FEB2010	TE Connectivity
DIMENSIONS:		CHK: D. STRAUSSER 22MAR2010	
mm	0 PLC ±0.2	APVD: D. STRAUSSER 27APR2010	ASSEMBLY, HEADER, 35 POSITION, VERTICAL, AMPSEAL
	1 PLC ±0.13	PRODUCT SPEC: 108-1329	
	2 PLC ±0.13	APPLICATION SPEC: 114-16016	SIZE: A1
	3 PLC ±0.13	WEIGHT: -	CAGE CODE: -
	4 PLC ±0.13	CUSTOMER DRAWING	SCALE: 4:1
	ANGLES ±0.4°		SHEET: 2 OF 2
			REV: A9

## X-ON Electronics

Largest Supplier of Electrical and Electronic Components

*Click to view similar products for [Automotive Connectors](#) category:*

*Click to view products by [TE Connectivity](#) manufacturer:*

Other Similar products are found below :

[003-018-000](#) [600858](#) [60403001](#) [60993906-B](#) [60993913-B](#) [629515004020001](#) [M902-2131](#) [M902-2161](#) [M902-2344](#) [72.330.1035.1](#)  
[73.353.4028.0](#) [F118010](#) [F119300-B](#) [F132210](#) [F132210-B](#) [F166900](#) [F180100](#) [F258300](#) [F258300-B](#) [F294300-B](#) [F339100](#) [F339700](#) [F358300-](#)  
[B](#) [F374110](#) [F407400](#) [F412210](#) [F427600](#) [F444110](#) [F487000](#) [F495100-B](#) [F500900-B](#) [F509500B-B](#) [770444-1](#) [776880-1](#) [827153-1](#) [881735-1](#)  
[8N1515-32-24P](#) [9-1326729-8](#) [925467-1](#) [925474-1](#) [928905-1](#) [936398-2](#) [964562-1](#) [964562-4](#) [964731-2](#) [965051-1](#) [968782-1](#) [GT17SA-8DS-](#)  
[HU](#) [GT17VS-10DP-5.2CF](#) [98315-0001](#)