

## 8-Bit, 2-Port Bus Switch

### Features

- Near-Zero propagation delay
- 5-ohm switches connect inputs to outputs
- Direct bus connection when switches are on
- Ultra Low Quiescent Power (0.2µA typical)
  - Ideally suited for notebook applications
- Pin compatible with 74 Series 245 logic devices
- Packaging (Pb-free & Green):
  - 20-pin 173-mil wide plastic TSSOP (L)
  - 20-pin 150-mil wide plastic QSOP (Q)

### Description

Pericom Semiconductor's PI5C3245 is a 8-bit, 2-port bus switch designed with a low On-Resistance (5-ohm) allowing inputs to be connected directly to outputs. The bus switch creates no additional propagational delay or additional ground bounce noise. The switches are turned on by the Bus Enable ( $\overline{BE}$ ) input signal. The pinout is compatible with PI74FCT245T (Octal Bidirectional Transceiver).

### Block Diagram

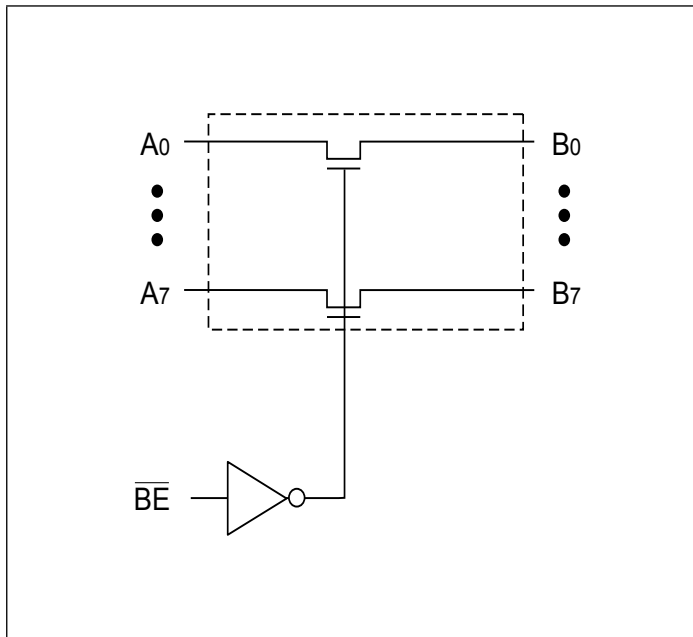

### Pin Configuration

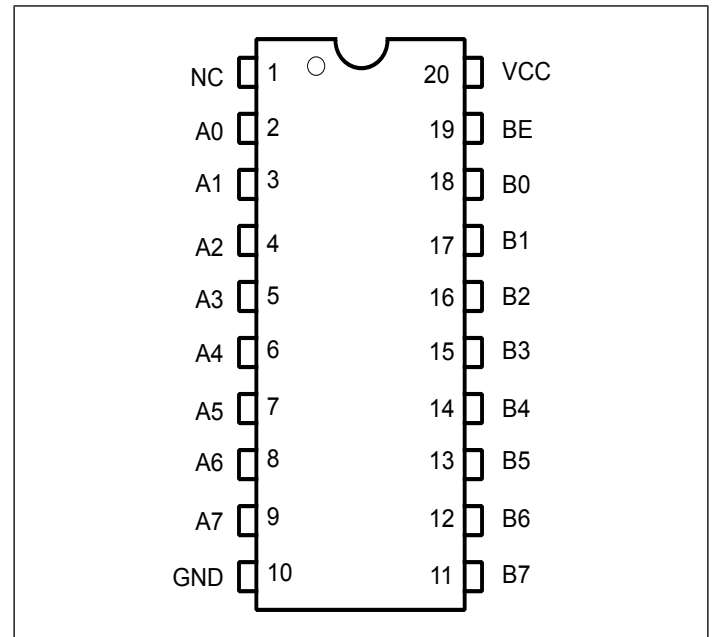

### Truth Table<sup>(1)</sup>

Function	$\overline{BE}$	A0-7
Disconnect	H	Hi-Z
Connect	L	B0-7

Note: 1. H = High Voltage Level  
L = Low Voltage Level  
Hi-Z = High Impedance

### Pin Description

Pin Name	Description
$\overline{BE}$	Bus Enable Input (Active LOW)
A0-7	Bus A
B0-7	Bus B
GND	Ground
VCC	Power

## Absolute Maximum Ratings

Parameter	Min.	Max.	Units
Storage Temperature	-65	150	°C
Ambient Temperature with Power Applied	-40	85	°C
Supply Voltage to Ground Potential (Inputs & V <sub>CC</sub> Only)	-0.5	7.0	V
Supply Voltage to Ground Potential (Outputs & D/O Only)	-0.5	7.0	V
DC Input Voltage	-0.5	7.0	V
DC Output Current	-	120	mA
Power Dissipation	-	0.5	W

Stress beyond those listed under “Absolute Maximum Ratings” may cause permanent damage to the device.

## DC Electrical Characteristics (Over the Operating Range, T<sub>A</sub> = -40°C to +85°C, V<sub>CC</sub> = 5V ±5%)

Parameters	Description	Test Conditions <sup>(1)</sup>	Min	Typ <sup>(2)</sup>	Max	Units
V <sub>IH</sub>	Input HIGH Voltage	Guaranteed Logic HIGH Level	2.0			V
V <sub>IL</sub>	Input LOW Voltage	Guaranteed Logic LOW Level	-0.5		0.8	V
I <sub>IH</sub>	Input HIGH Current	V <sub>CC</sub> = Max., V <sub>IN</sub> = V <sub>CC</sub>			±1	μA
I <sub>IL</sub>	Input LOW Current	V <sub>CC</sub> = Max., V <sub>IN</sub> = GND			±1	μA
I <sub>OZH</sub>	High Impedance Output Current	0 ≤ A, B ≤ V <sub>CC</sub>			±1	μA
V <sub>IK</sub>	Clamp Diode Voltage	V <sub>CC</sub> = Min, I <sub>IN</sub> = -18mA	-0.7	-1.2		V
I <sub>OS</sub>	Short Circuit Current <sup>(3)</sup>	A (B) = 0V, B (A) = V <sub>CC</sub>	100			mA
V <sub>H</sub>	Input Hysteresis at Control Pins			150		mV
R <sub>ON</sub>	Switch On Resistance <sup>(4)</sup>	V <sub>CC</sub> = Min, V <sub>IN</sub> = 0.0V, I <sub>ON</sub> = 48 mA		5	7	Ω
		V <sub>CC</sub> = Min, V <sub>IN</sub> = 2.4V, I <sub>ON</sub> = 15 mA		10	15	

Notes:

- For Max. or Min. conditions, use appropriate value specified under Electrical Characteristics for the applicable device type.
- Typical values are at V<sub>CC</sub> = 5.0V, T<sub>A</sub> = 25°C ambient and maximum loading.
- Not more than one output should be shorted at one time. Duration of the test should not exceed one second.
- Measured by the voltage drop between A and B pin at indicated current through the switch. ON resistance is determined by the lower of the voltages on the two (A,B) pins.

## Capacitance (T<sub>A</sub> = 25°C, f = 1 MHz)

Parameters <sup>(1)</sup>	Description	Test Conditions	Typ	Units
C <sub>IN</sub>	Input Capacitance	V <sub>IN</sub> = 0V	6	pF
C <sub>OFF</sub>	A/B Capacitance, Switch Off	V <sub>IN</sub> = 0V	6	pF
C <sub>ON</sub>	A/B Capacitance, Switch On	V <sub>IN</sub> = 0V	8	pF

Notes:

- This parameter is determined by device characterization but is not production tested.

### Power Supply Characteristics

Parameters	Description	Test Conditions <sup>(1)</sup>		Min	Typ <sup>(2)</sup>	Max	Units
I <sub>CC</sub>	Quiescent Power Supply Current	V <sub>CC</sub> = Max.	V <sub>IN</sub> = GND or V <sub>CC</sub>		0.1	3.0	μA
ΔI <sub>CC</sub>	Supply Current @ Input HIGH	V <sub>CC</sub> = Max.	V <sub>IN</sub> = 3.4V <sup>(3)</sup>			2.5	mA
I <sub>CCD</sub>	Supply Current per Input per MHz <sup>(4)</sup>	V <sub>CC</sub> = Max. A and B Pins Open $\overline{BE}$ = GND Control Input Toggling 50% Duty Cycle				0.25	mA/ MHz

Notes:

1. For Max. or Min. conditions, use appropriate value specified under Electrical Characteristics for the applicable device.
2. Typical values are at V<sub>CC</sub> = 5.0V, +25°C ambient.
3. Per TTL driven input (V<sub>IN</sub> = 3.4V, control inputs only); A and B pins do not contribute to I<sub>CC</sub>.
4. This current applies to the control inputs only and represent the current required to switch internal capacitance at the specified frequency. The A and B inputs generate no significant AC or DC currents as they transition. This parameter is not tested, but is guaranteed by design.

### Switching Characteristics over Operating Range

Parameters	Description	Test Conditions	Com.		Units
			Min	Max	
t <sub>PLH</sub> t <sub>PHL</sub>	Propagation Delay <sup>(1,2)</sup> Ax to Bx, Bx to Ax	C <sub>L</sub> = 50 pF R <sub>L</sub> = 500Ω		0.25	ns
t <sub>PZH</sub> t <sub>PZL</sub>	Bus Enable Time $\overline{BE}$ to Ax or Bx		1.5	6.5	
t <sub>PHZ</sub> t <sub>PLZ</sub>	Bus Disable Time $\overline{BE}$ to Ax or Bx		1.5	5.5	

Notes:

1. This parameter is guaranteed but not tested on Propagation Delays.
2. The bus switch contributes no propagational delay other than the RC delay of the On-Resistance of the switch and the load capacitance. The time constant for the switch alone is of the order of 0.25 ns for 50 pF load. Since this time constant is much smaller than the rise/fall times of typical driving signals, it adds very little propagational delay to the system. Propagational delay of the bus switch when used in a system is determined by the driving circuit on the driving side of the switch and its interaction with the load on the driven side.

**Packaging Mechanical: 20-pin TSSOP (L20)**

DOCUMENT CONTROL NO.  
PD - 1311

REVISION: E  
DATE: 03/09/05

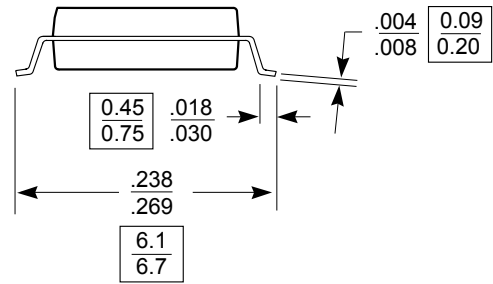
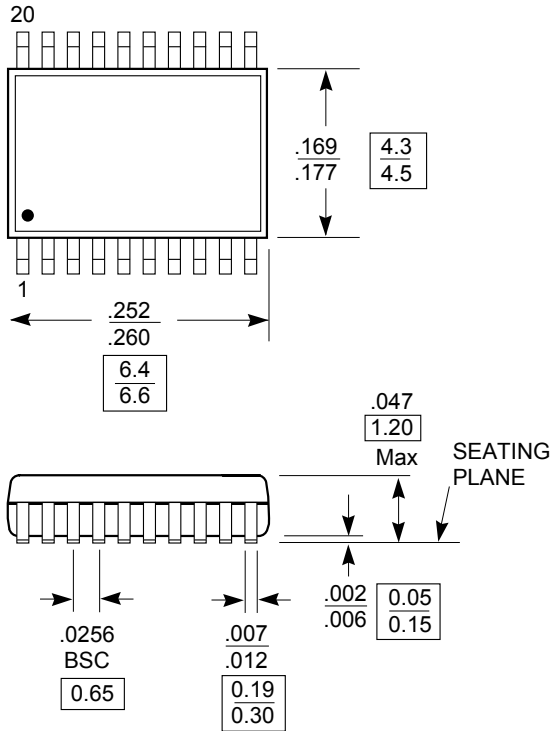

- Note:**
1. Package Outline Exclusive of Mold Flash and Metal Burr
  2. Controlling dimensions in millimeters
  3. Ref: JEDEC MO-153F/AC



Pericom Semiconductor Corporation  
3545 N. 1st Street, San Jose, CA 95134  
1-800-435-2336 • www.pericom.com

DESCRIPTION: 20-Pin, 173-Mil Wide, TSSOP

PACKAGE CODE: L

**Packaging Mechanical: 20-pin QSOP (Q20)**

DOCUMENT CONTROL NO.

PD - 1202

REVISION: H

DATE: 10/22/07

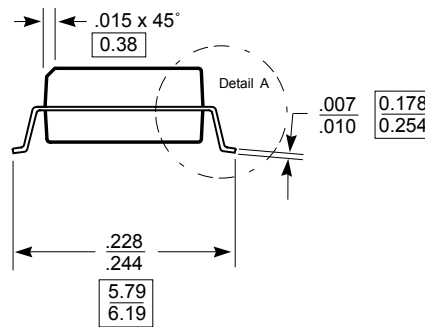
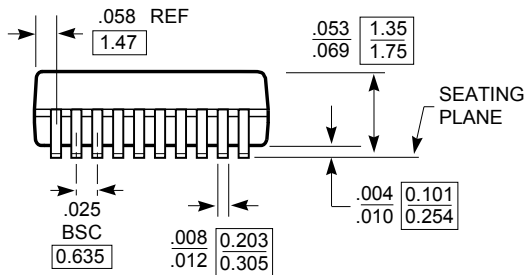
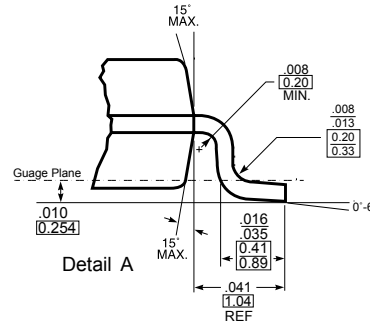
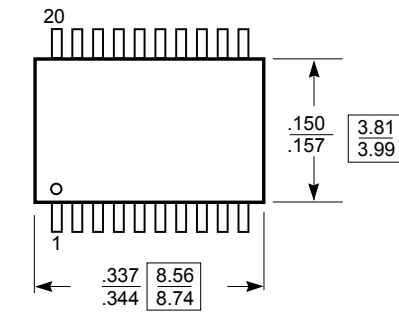

X.XX DENOTES DIMENSIONS IN INCHES  
 X.XX IN MILLIMETERS

Note:

- 1) Controlling dimensions in inches.
- 2) Ref: JEDEC MO-137B/AD
- 3) Dimensions do not include mold flash, protrusions or gate burrs



Pericom Semiconductor Corporation  
 3545 N. 1st Street, San Jose, CA 95134  
 1-800-435-2335 • www.pericom.com

DESCRIPTION: 20-Pin, 150-Mil Wide, QSOP

PACKAGE CODE: Q

**Ordering Information**

Ordering Code	Package Code	Package Type
PI5C3245LE	L	Pb-free & Green, 20-pin 173-mil wide plastic TSSOP
PI5C3245QE	Q	Pb-free & Green, 20-pin 150-mil wide plastic QSOP

1. Thermal characteristics can be found on the company web site at [www.pericom.com/packaging/](http://www.pericom.com/packaging/)

## X-ON Electronics

Largest Supplier of Electrical and Electronic Components

*Click to view similar products for [Digital Bus Switch ICs](#) category:*

*Click to view products by [Diodes Incorporated](#) manufacturer:*

Other Similar products are found below :

[MT8986AE1](#) [MT90812AP1](#) [MT90869AG2](#) [CA91L8260B-100CEV](#) [TC7MPB9307FT\(EL\)](#) [MT8986AP1](#) [72V8985JG8](#) [732757E](#)  
[ZL50020QCG1](#) [ZL50012QCG1](#) [PI3C32X384BE](#) [PI5C3861QEX](#) [ZL50023GAG2](#) [MT8986AL1](#) [MT8981DP1](#) [PI3VT3245-ALE](#)  
[ZL50016GAG2](#) [TC7MBL3257CFT\(EL\)](#) [PI3CH800QE](#) [MT90823AB1](#) [ZL50075GAG2](#) [PI5C32X245BEX](#) [PI5C3126QEX](#) [PI5C3125QEX](#)  
[PI3VT3245-AQE](#) [PI3CH800QEX](#) [PI3C3384QE](#) [PI3C3305UEX](#) [PI3B3861QEX](#) [PI3B3861QE](#) [PI3B32X245BEX](#) [PI3B3245QEX](#)  
[PI3B3245QE](#) [PI3CH800ZHEX](#) [PI3CH1000LE](#) [PI3CH400ZBEX](#) [728981JG8](#) [TC7MBL3257CFK\(EL\)](#) [728985JG8](#) [PI3CH401LE](#)  
[PI3CH401LEX](#) [FST3126DR2G](#) [QS34X245Q3G8](#) [QS3VH125S1G8](#) [TC7WBL3305CFK\(5L,F](#) [74CB3Q3125DBQRE4](#) [74FST6800PGG8](#)  
[74CB3Q3244DBQRE4](#) [74CBTLV3125PGG8](#) [TC7MBL3125CFT\(EL\)](#)