

Description

The AP1694AS-13 is a high performance AC-DC power factor corrector for mains dimmable LED driver applications. The device uses Pulse Frequency Modulation (PFM) technology to regulate output current while achieving high power factor and low THD. It operates as a BCM (Boundary Conduction Mode) controller which is good for EMI.

The AP1694AS-13 provides accurate constant current (CC) regulation while removing the opto-coupler and secondary control circuitry. It also eliminates the need for loop compensation circuitry while maintaining stability. It can meet the requirement of IEC6100-3-2 harmonic standard.

The AP1694AS-13 features low start-up current and low operation current. It adopts valley on switching mode to achieve high efficiency. It also has rich protection features including overvoltage, short circuit, and over-temperature protection.

The AP1694AS-13 provides the dimmable LED driver with a wide dimmer compatibility including leading edge and trailing edge dimmer. The AP1694AS-13 can achieve deep dimming down to 1%, while the dimming curve is compliant with the standard of NEMA SSL6.

The AP1694AS-13 is available in SO-8 package.

Applications

- Mains Dimmable LED Lighting

- Notes:
1. No purposely added lead. Fully EU Directive 2002/95/EC (RoHS) & 2011/65/EU (RoHS 2) compliant.
 2. See http://www.diodes.com/quality/lead_free.html for more information about Diodes Incorporated's definitions of Halogen- and Antimony-free, "Green" and Lead-free.
 3. Halogen- and Antimony-free "Green" products are defined as those which contain <900ppm bromine, <900ppm chlorine (<1500ppm total Br + Cl) and <1000ppm antimony compounds.

Pin Assignments

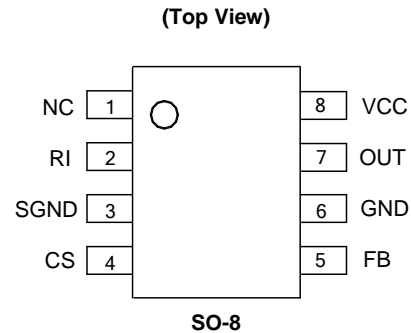

Features

- Primary Side Control for Output Current Regulation without Opto-coupler
- Boundary Conduction Mode (BCM) Operation to Achieve High-efficiency
- High PF and Low THD (PF > 0.9, THD < 30%)
- High Efficiency without Dimmer
- Wide Range of Dimmer Compatibility
- Dimming Curve Compliant with NEMA SSL6
- Low Start-Up Current
- Tight LED Current
- Tight LED Open Voltage
- Valley-Mode Switching to Minimize the Transition Loss
- Mosfet Driver up to 25W
- Easy EMI
- Internal Protections:
 - Under Voltage Lock Out(UVLO)
 - Leading-Edge Blanking (LEB)
 - Output Short Protection
 - Output Open Protection
 - Over Temperature Protection
- Flexible for Design with Small Form Factor and Very Low BOM Cost
- Totally Lead-Free & Fully RoHS Compliant (Notes 1 & 2)**
- Halogen and Antimony Free. "Green" Device (Note 3)**

Typical Applications Circuit

NEW PRODUCT

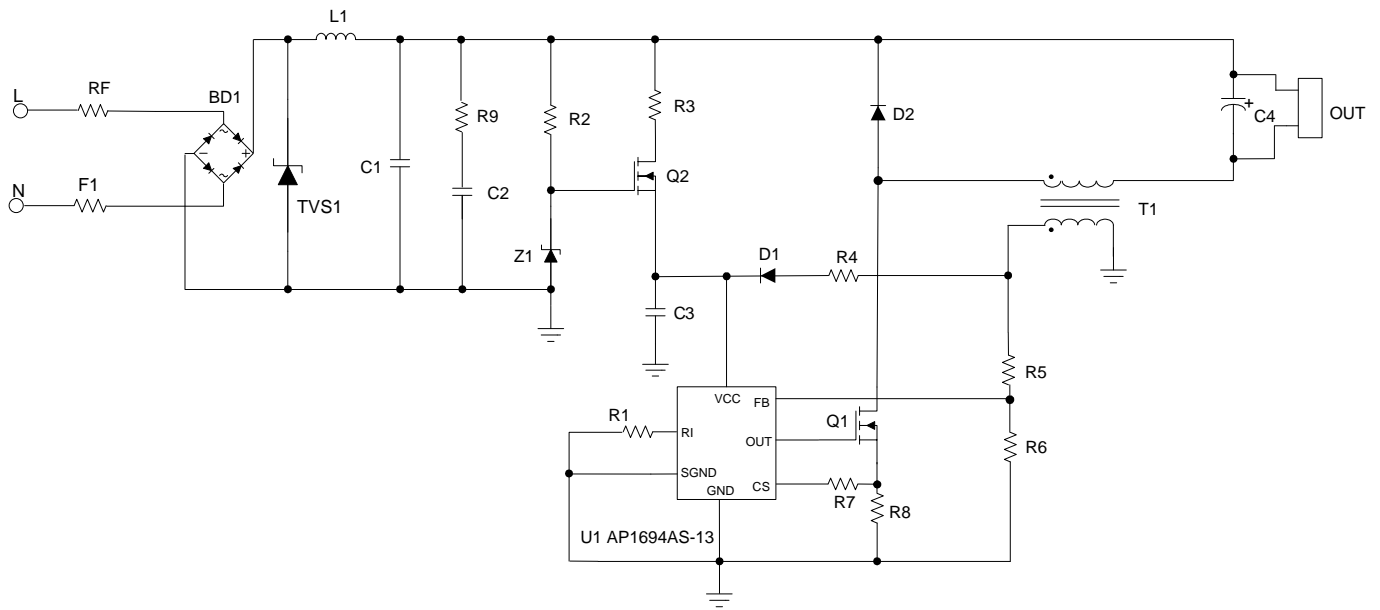

Typical Buck Application

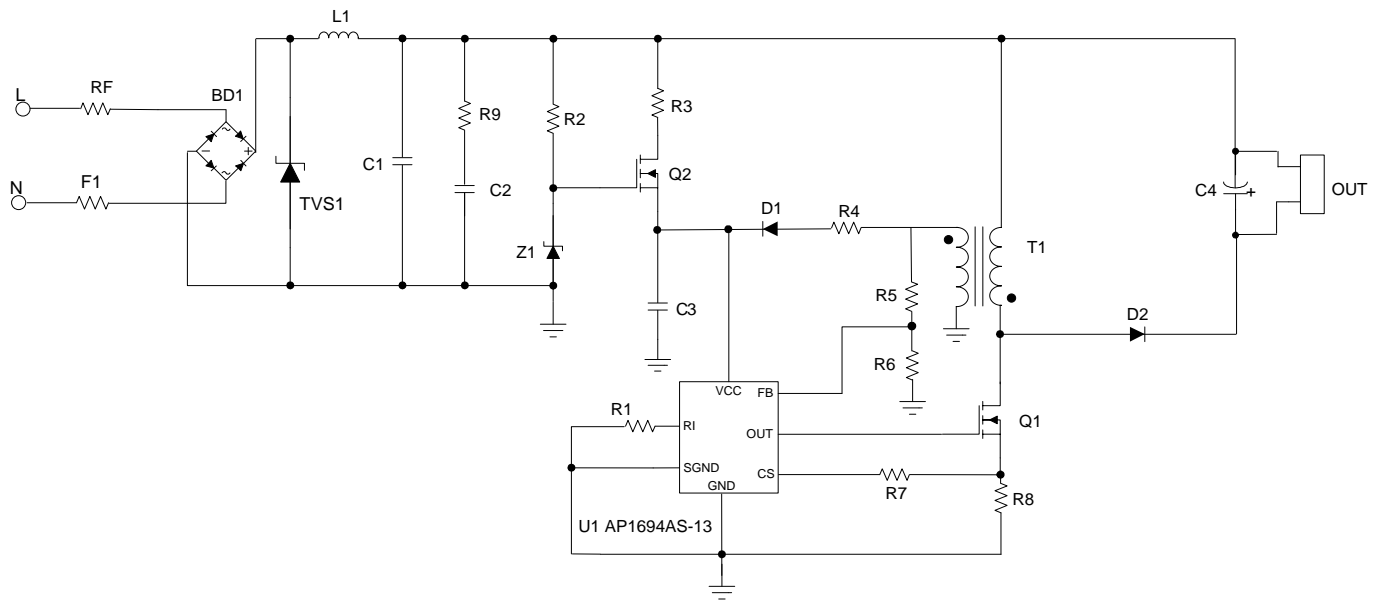

Typical Buck-Boost Application

Typical Applications Circuit (continued)

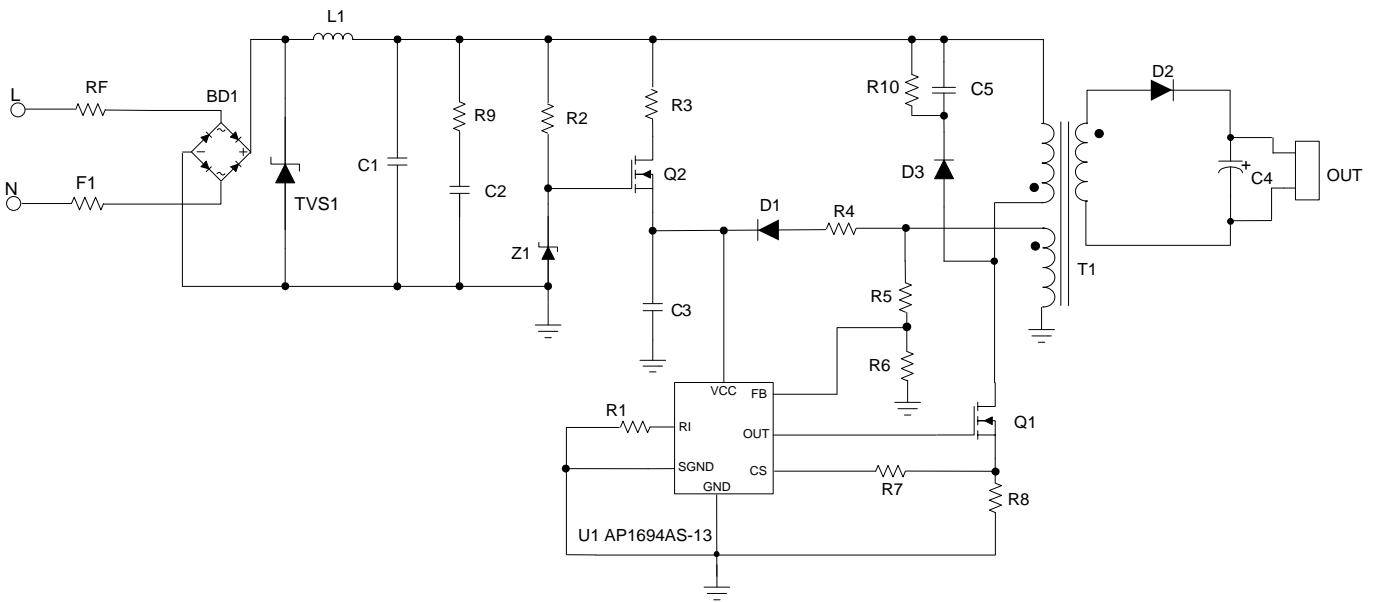

Typical Fly-Back Application

Pin Descriptions

Pin Number	Pin Name	Function
1	NC	No connection.
2	RI	The initial on time setting resistor.
3	SGND	Must connect to GND.
4	CS	Primary current sensing.
5	FB	The feedback voltage from auxiliary winding.
6	GND	Ground.
7	OUT	Gate driver output.
8	VCC	Supply voltage of gate driver and control circuits of the IC.

Functional Block Diagram

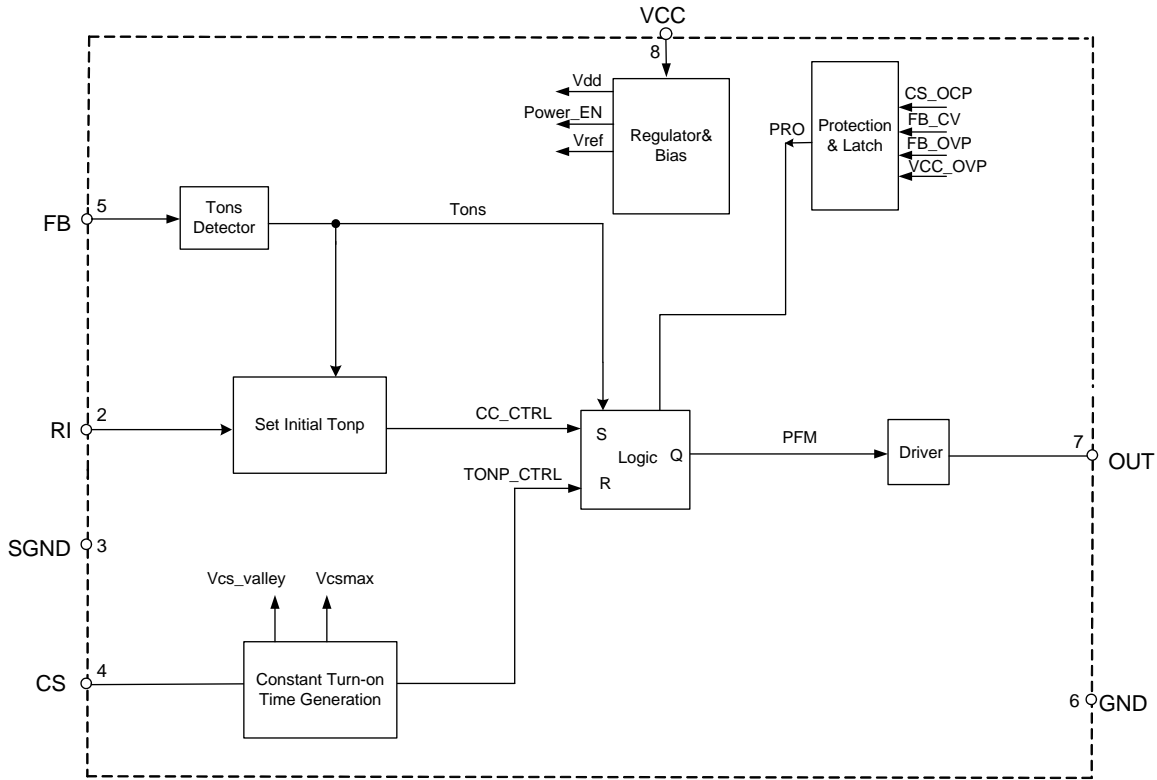

Absolute Maximum Ratings (Note 4) (@T_A = +25°C, unless otherwise specified.)

Symbol	Parameter	Rating	Unit
V _{CC}	Power Supply Voltage	-0.3 to 35	V
I _{OUT}	Driver Output Current	150	mA
V _{CS}	Voltage at CS to GND	-0.3 to 7	V
V _{FB}	FB Input Voltage	-40 to 10	V
T _J	Operating Junction Temperature	-40 to +150	°C
T _{STG}	Storage Temperature	-65 to +150	°C
T _{LEAD}	Lead Temperature (Soldering, 10 sec)	+300	°C
P _D	Power Dissipation (T _A = +50°C)	0.65	W
θ _{JA}	Thermal Resistance (Junction to Ambient)	160	°C/W
–	ESD (Human Body Model)	±2,000	V
–	ESD (Machine Model)	±200	V

Note 4: Stresses greater than those listed under “Absolute Maximum Ratings” may cause permanent damage to the device. These are stress ratings only, and functional operation of the device at these or any other conditions beyond those indicated under “Recommended Operating Conditions” is not implied. Exposure to “Absolute Maximum Ratings” for extended periods may affect device reliability.

Recommended Operating Conditions

Symbol	Parameter	Min	Max	Unit
V _{CC}	Power Supply Voltage	7	25	V
T _A	Ambient Temperature	-40	+105	°C

Electrical Characteristics (@T_A = +25°C, unless otherwise specified.)

Symbol	Parameter	Conditions	Min	Typ	Max	Unit
UVLO Section						
V _{TH} (ST)	Start-up Threshold	–	13	14.5	16	V
V _{OPR} (Min)	Minimum Operating Voltage	After turn on	5.5	6.5	7.5	V
V _{CC_OVP}	VCC OVP Voltage	–	27	29	31	V
–	VCC Delatch Voltage (Note 5)	–	3	4	5	V
Standby Current Section						
I _{ST}	Start-up Current	V _{CC} = V _{TH} (ST) -0.5V, Before start up	–	–	20	μA
I _{CC} (OPR)	Operating Current	Static	–	900	1,300	μA
Drive Output Section						
V _{GATE}	Gate Voltage	–	11	12	14	V
I _{SOURCE_L}	Low Driver Source Current	–	35	40	45	mA
I _{SOURCE_H}	High Driver Source Current	–	90	100	120	mA
R _{DS(on)}	Sink Resistance	–	6	7	8	Ω
Current Sense Section						
V _{CS_REF}	Current Sense Reference	–	–	1	–	V
V _{CS_CLAMP}	Current Sense Reference Clamp	–	1.2	1.4	–	V
t _{ONP_MIN}	Minimum t _{ONP}	–	700	–	1,000	ns
t _{D(H-L)}	Delay to Output (Note 5)	–	50	150	250	ns
Feedback Input Section						
I _{FB}	Feedback Pin Input Leakage Current	V _{FB} = 2V	–	–	4	μA
V _{FB_CV}	FB CV Threshold	–	3.8	4	4.2	V
V _{FB_OVP}	FB OVP Threshold	–	4.5	6	7.5	V
Output Current						
–	System Output Current On Final Test Board	–	–	–	±2	%
Over Temperature Protection Section						
–	Shutdown Temperature (Note 5)	–	+150	–	–	°C
–	Temperature Hysteresis (Note 5)	–	–	+20	–	°C

Note 5: These parameters, although guaranteed by design, are not 100% tested in production.

Performance Characteristics

CV Threshold vs. Supply Voltage

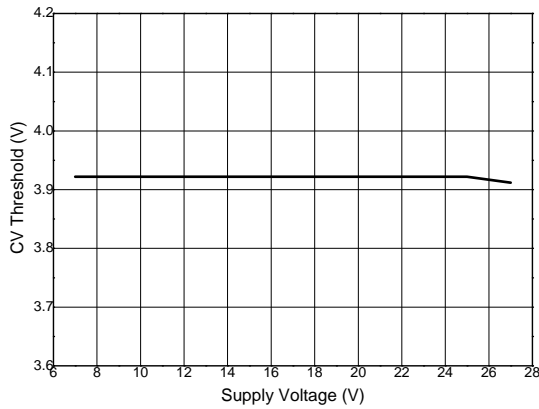

Start-up Voltage vs. Ambient Temperature

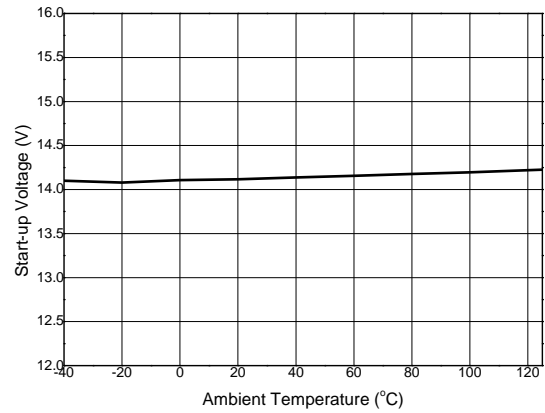

Minimal Operating Voltage vs. Ambient Temperature

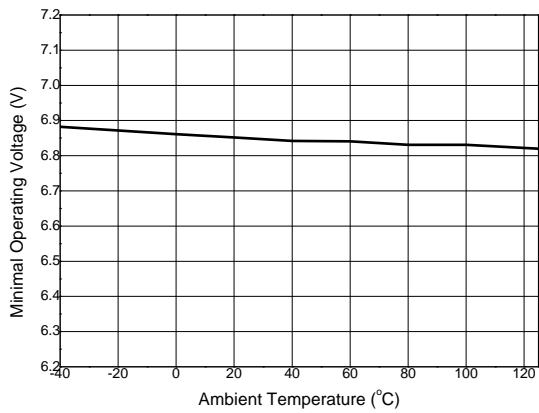

Start-up Current vs. Ambient Temperature

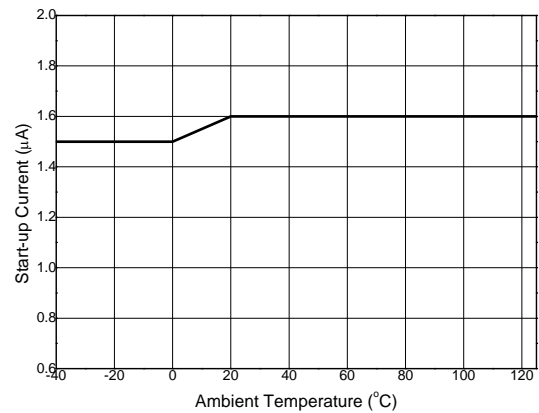

Operating Current vs. Ambient Temperature

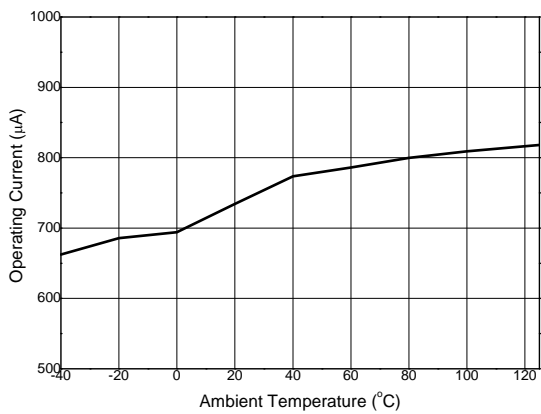

CV Threshold vs. Ambient Temperature

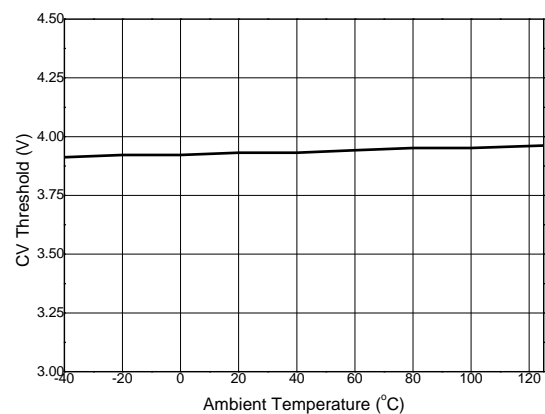

Performance Characteristics (continued)

FB Leakage Current vs. Ambient Temperature

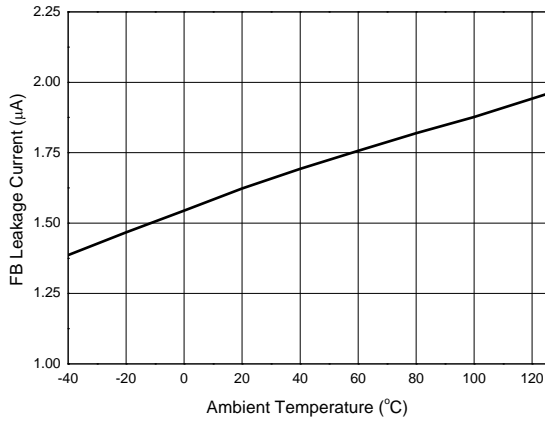

Supply Current vs. Supply Voltage

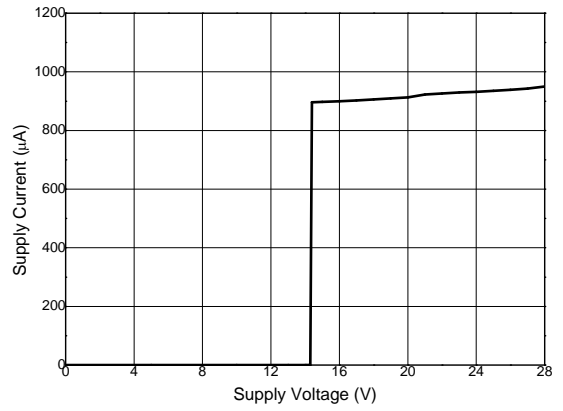

Application Information Based on Buck Structure

The AP1694AS-13 uses constant on time control method within one AC cycle to achieve the high power factor. When the dimmer is connected to the driver, although a part of input voltage is cut off by the dimmer, the system still operates in constant on time mode. In this way, good dimmer compatibility can be realized.

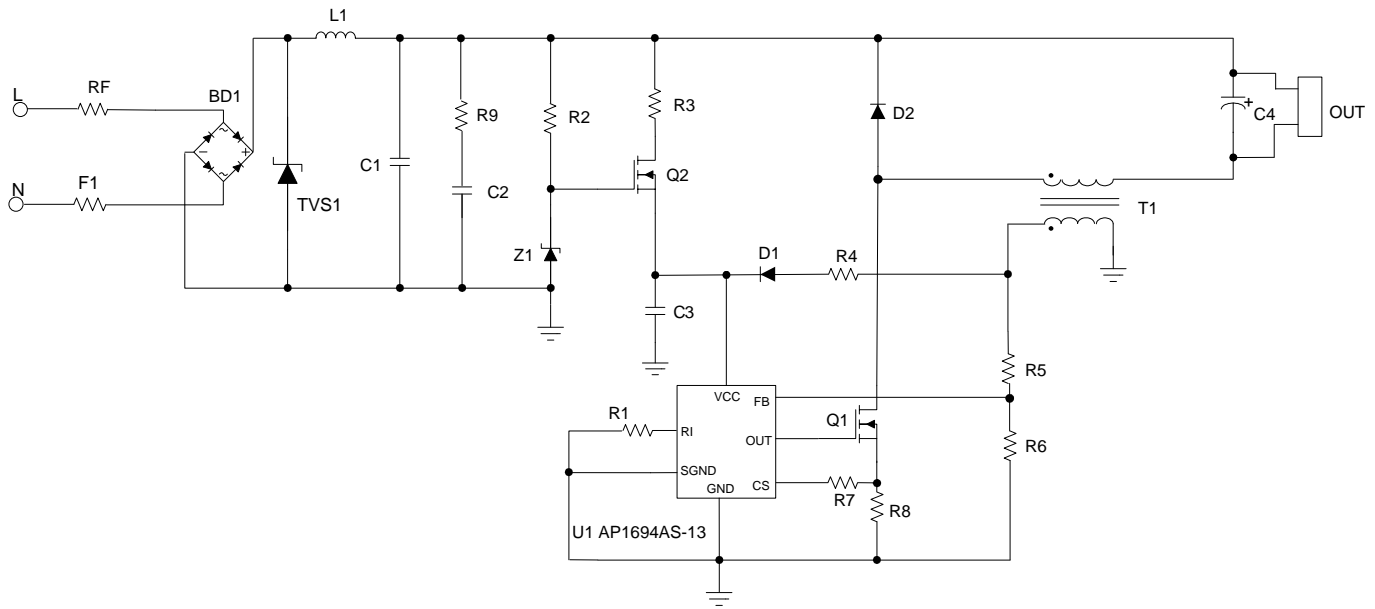

Figure 1. Typical Buck Application Circuit

When the dimmer is connected, and the conduction angle of the dimmer is $\pi - \alpha$; according to the control principle of the IC, the output current can be determined as:

$$I_o(\alpha, \theta) = \frac{1}{2} \cdot I_{pk}(\alpha, \theta) = \begin{cases} \frac{1}{2} \cdot \frac{V_{cs_ref}}{R8} \cdot \sin(\theta) & \text{if } (\theta > \alpha) \\ 0 & \text{else} \end{cases}$$

In consideration of the dead zone of the buck structure, the output current DC value can be calculated as below:

$$I_{o_mean} = k \cdot \frac{1}{\pi} \int_0^{\pi} I_o(\alpha, \theta) d\theta$$

Where,

V_{cs_ref} is the reference of the current sense, and the typical value is 1V.

α is the cutoff angle of dimmer.

θ is the phase of the input voltage.

k is the current modification coefficient, and the value is approximate to be 0.7.

When no dimmer is connected with the driver ($\alpha = 0$), the output current DC value can be calculated by:

$$I_{o_mean} = k \cdot \frac{1}{\pi} \cdot \frac{V_{cs_ref}}{R8}$$

Application Information Based on Buck Structure (continued)

Design Parameters

Setting the Current Sense Resistor R8

According to the equation of the output current, the current sense resistor R8 is determined:

$$R8 = k \cdot \frac{V_{cs_ref}}{\pi \cdot I_{o_mean}}$$

Transformer Selection

The typical non-isolated buck circuit in Figure 1 is usually selected, and the system is operating at boundary conduction mode. The switching frequency at the crest is set as f_{min} , the inductance can be calculated as below:

$$L = \frac{(\sqrt{2} \cdot V_{in_rms} - V_o) \cdot R8 \cdot V_o}{V_{cs_ref} \cdot \sqrt{2} \cdot V_{in_rms} \cdot f_{min}}$$

Where,

V_o is the output voltage.

V_{in_rms} is the RMS value of the input voltage.

According to Ferrari's law of electromagnetic induction, the winding turns number of the buck inductance N_L is:

$$N_L = \frac{L \cdot i_{pk}}{A_e \cdot B_m} = \frac{L \cdot V_{cs_ref}}{A_e \cdot B_m \cdot R8}$$

Where,

A_e is the core effective area.

B_m is the maximum magnetic flux density.

The auxiliary winding is the power supply for V_{CC} , the winding turns number N_{aux} is:

$$N_{aux} = N_L \cdot \frac{V_{cc}}{V_o + V_d}$$

Where,

V_{CC} is the power supply voltage for IC from auxiliary winding.

V_d is the voltage drop of the freewheel diode.

Setting the Initial On Time

As the AP1694AS-13 adopts the constant on time control method, the AP1694AS-13 will generate an initial on time to start a working cycle. If the initial on time is longer than the rated on time, overshoot will happen. The initial on time is determined by resistor R1 shown in Figure 1.

According to the initial on time generation mechanism, the $t_{on_initial}$ is:

$$t_{on_initial} = 80 \cdot R1 \cdot 10^{-12} s$$

To guarantee the system with no overshoot phenomenon, the resistor R1 is selected:

$$R1 \leq \frac{1.25 \cdot L}{R8 \cdot \sqrt{2} U_{in_rms_max}} \cdot 10^{10} \Omega$$

Application Information Based on Buck Structure (cont.)

In dimmable application, on the condition of the acceptable line regulation, the smaller R1 is selected, as it will be better for dimming performance.

Valley On Control Method

The valley on function can provide low turn-on switching losses for buck converter. The voltage across the power-switch is reflected by the auxiliary winding of the buck transformer. The voltage is sensed by FB pin.

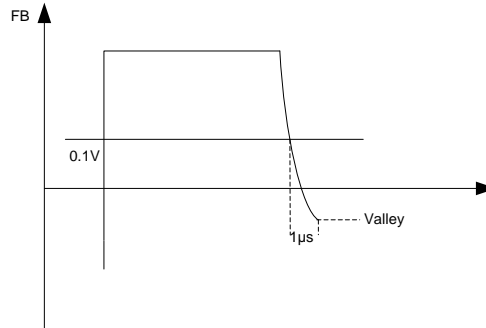

Figure 2. Valley On-Control

According to Figure 2, when the falling edge of 0.1V is sensed by FB pin, the AP1694AS-13 will see the toff time is over and delay 1µs to start a new operating cycle. By this way we can realize valley on function.

Passive Damping and Bleeder Design

The passive bleeder is designed to supply latching and holding current to eliminate misfire and flicker.

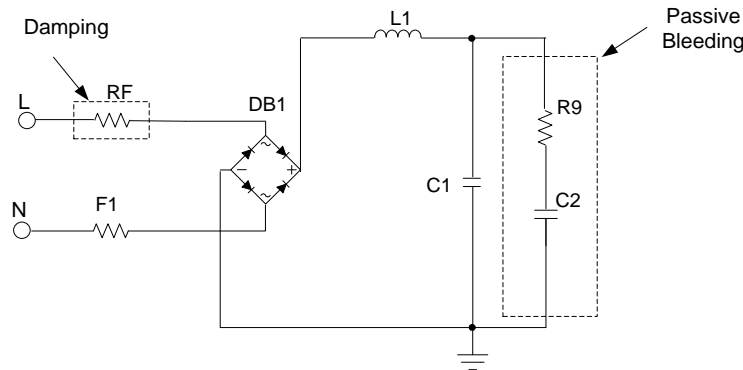

Figure 3. LED Driver Schematic with Passive Bleeder

A passive bleeder is composed of a resistor (R9) and a capacitor (C2). C1 is input filter capacitor and RF is damper resistor.

The passive bleeder includes a capacitor (C2, hundreds of nF) to provide latching current. To remove the voltage and current spike, a resistor (R9) is necessary to dampen the spike.

In dimmable application, because a large C2 will affect the PF, THD and efficiency, the value of the capacitor (C2) selected should be suitable. Generally, 100nF/400V to 330nF/400V is recommended.

RF is the damper for reducing the spike current caused by quick charging of C2 at firing. RF is selected from 20Ω to 100Ω for low-line application, and 51Ω to 200Ω for high-line application. If R9 is too small, R9 can't fully dampen the spike current and ringing current will occur. The ringing current will cause the TRIAC misfire which will cause LED flicking. Another consideration in R9 selection is power loss; an R9 that is too large will make more power dissipation. Generally, a 200Ω to 2KΩ resistor is selected for R9.

Application Information Based on Buck Structure (cont.)

**Fault Protection
Over Voltage Protection and Output Open Protection**

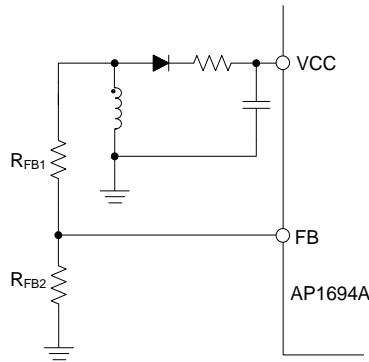

Figure 4. OVP Circuit

The output voltage is sensed by the auxiliary winding voltage of the Buck transformer. The VCC pin and FB pin provide over voltage protection function. When the output is open or large transient happens, the output voltage will exceed the rated value. When the voltage of $V_{CC\ cap}$ exceeds V_{CC_OVP} or V_{FB_CV} , the over voltage is triggered and the IC will discharge V_{CC} . When the V_{CC} is below the UVLO threshold voltage, IC will start a new work cycle and the $V_{CC\ cap}$ is charged again by start resistance. If the over voltage condition still exists, the system will work in hiccup mode.

Attention: If the external fast startup circuit is adding in the application and the over voltage protection and output open protection happen, the IC will trigger latch.

Output Short Protection

When the output is shorted, the output voltage will be clamped at zero. At this condition, V_{CC} will drop down without auxiliary winding for power supply, and the V_{CC} will drop to UVLO threshold voltage. The IC will shut down and restart a new operating cycle, and the V_{CC} is charged by startup resistance. When V_{CC} is higher than V_{CC_start} voltage, IC will output a bunch of pulses to control power switch on and off. When still no FB signal detected, the device will not output more pulses. The V_{CC} will again drop to V_{CC} UVLO threshold. If output short condition still exists, the system will operate in hiccup mode.

Attention: If the external fast startup circuit is adding in the application, the device will not work at UVLO mode, and the device will work at minimum toff mode.

Over Temperature Protection

AP1694AS-13 has two kinds of over-temperature protection processes. First, if the system is operating normally, the ambient temperature is changed to +170°C, and suddenly the IC will trigger over-temperature protection which leads to a latch work mode. Second, if the system starts when the ambient temperature is higher than +150°C, over temperature protection will be triggered. So, the AP1694AS-13 can startup successfully when the ambient temperature is less than +150°C.

Components Selection Guide

If the system's spec is changed, please refer to the design sheet of the AP1694AS-13 and select the compatible system parameter. When the system needs to be adjusted slightly, please refer to the table below and adjust the value of the related component.

Item	Description	Related Components
I_o	Output current	R8
Output Current Ripple	Small current ripple is good for LED life	C4
$t_{on_initial}$	System initial on time, used to startup the system	R1
Output Open Voltage	Setting the output voltage when the LED is open	R5, R6
Dimming Performance	Improve the dimming performance	R1, RF, R9, C2, C4
EMI	Pass EN 55022 class B with 6DB margin	L1, C1
Line Compensation	To get a good line regulation	R7

Ordering Information

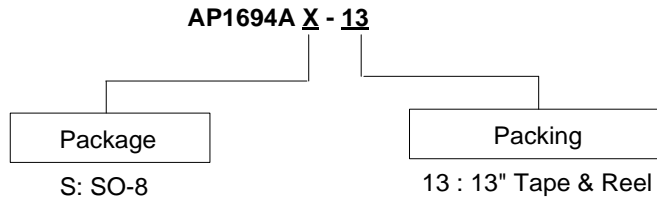

Part Number	Package Code	Packaging	13" Tape and Reel	
			Quantity	Part Number Suffix
AP1694AS-13	S	SO-8	4,000/Tape & Reel	-13

Marking Information

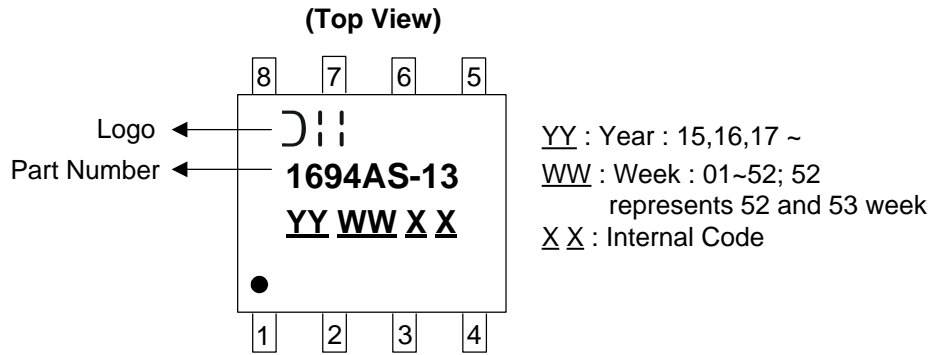

Package Outline Dimensions (All dimensions in mm (inch).)

Please see AP02002 at <http://www.diodes.com/datasheets/ap02002.pdf> for the latest version.

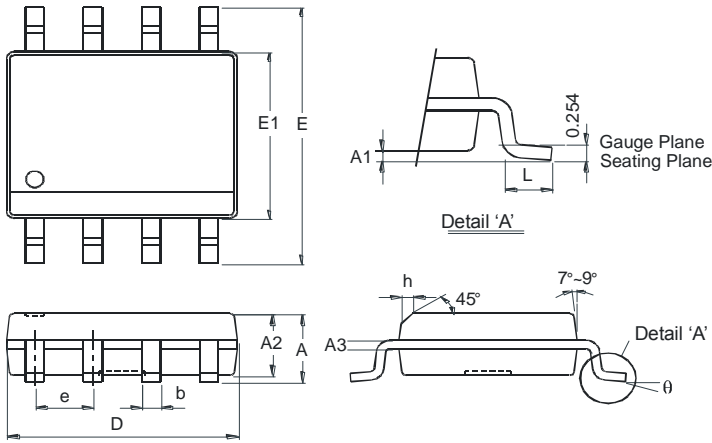

SO-8		
Dim	Min	Max
A	-	1.75
A1	0.10	0.20
A2	1.30	1.50
A3	0.15	0.25
b	0.3	0.5
D	4.85	4.95
E	5.90	6.10
E1	3.85	3.95
e	1.27 Typ	
h	-	0.35
L	0.62	0.82
θ	0°	8°
All Dimensions in mm		

Suggested Pad Layout

Please see AP02001 at <http://www.diodes.com/datasheets/ap02001.pdf> for the latest version

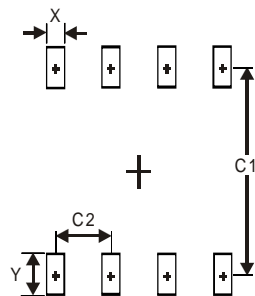

Dimensions	Value (in mm)
X	0.60
Y	1.55
C1	5.4
C2	1.27

IMPORTANT NOTICE

DIODES INCORPORATED MAKES NO WARRANTY OF ANY KIND, EXPRESS OR IMPLIED, WITH REGARDS TO THIS DOCUMENT, INCLUDING, BUT NOT LIMITED TO, THE IMPLIED WARRANTIES OF MERCHANTABILITY AND FITNESS FOR A PARTICULAR PURPOSE (AND THEIR EQUIVALENTS UNDER THE LAWS OF ANY JURISDICTION).

Diodes Incorporated and its subsidiaries reserve the right to make modifications, enhancements, improvements, corrections or other changes without further notice to this document and any product described herein. Diodes Incorporated does not assume any liability arising out of the application or use of this document or any product described herein; neither does Diodes Incorporated convey any license under its patent or trademark rights, nor the rights of others. Any Customer or user of this document or products described herein in such applications shall assume all risks of such use and will agree to hold Diodes Incorporated and all the companies whose products are represented on Diodes Incorporated website, harmless against all damages.

Diodes Incorporated does not warrant or accept any liability whatsoever in respect of any products purchased through unauthorized sales channel. Should Customers purchase or use Diodes Incorporated products for any unintended or unauthorized application, Customers shall indemnify and hold Diodes Incorporated and its representatives harmless against all claims, damages, expenses, and attorney fees arising out of, directly or indirectly, any claim of personal injury or death associated with such unintended or unauthorized application.

Products described herein may be covered by one or more United States, international or foreign patents pending. Product names and markings noted herein may also be covered by one or more United States, international or foreign trademarks.

This document is written in English but may be translated into multiple languages for reference. Only the English version of this document is the final and determinative format released by Diodes Incorporated.

LIFE SUPPORT

Diodes Incorporated products are specifically not authorized for use as critical components in life support devices or systems without the express written approval of the Chief Executive Officer of Diodes Incorporated. As used herein:

A. Life support devices or systems are devices or systems which:

1. are intended to implant into the body, or
2. support or sustain life and whose failure to perform when properly used in accordance with instructions for use provided in the labeling can be reasonably expected to result in significant injury to the user.

B. A critical component is any component in a life support device or system whose failure to perform can be reasonably expected to cause the failure of the life support device or to affect its safety or effectiveness.

Customers represent that they have all necessary expertise in the safety and regulatory ramifications of their life support devices or systems, and acknowledge and agree that they are solely responsible for all legal, regulatory and safety-related requirements concerning their products and any use of Diodes Incorporated products in such safety-critical, life support devices or systems, notwithstanding any devices- or systems-related information or support that may be provided by Diodes Incorporated. Further, Customers must fully indemnify Diodes Incorporated and its representatives against any damages arising out of the use of Diodes Incorporated products in such safety-critical, life support devices or systems.

Copyright © 2015, Diodes Incorporated

www.diodes.com

X-ON Electronics

Largest Supplier of Electrical and Electronic Components

Click to view similar products for [LED Lighting Drivers](#) category:

Click to view products by [Diodes Incorporated](#) manufacturer:

Other Similar products are found below :

[LV5235V-MPB-H](#) [MB39C602PNF-G-JNEFE1](#) [FAN5701UMP20X](#) [MIC2871YMK-T5](#) [MP1518DJ-LF-P](#) [MP3202DG-LF-P](#) [MP3304BDD-LF-P](#) [MP3306EG-LF-P](#) [MP3398AGY](#) [MP4033GK](#) [AL1676-10BS7-13](#) [AL1676-20AS7-13](#) [MX877RTR](#) [NCL30085BDR2G](#) [ICL8201](#) [IS31BL3506B-TTLS2-TR](#) [PAM2841GR](#) [A8519KLPTR-T](#) [FAN5701UMP08X](#) [FAN5702UMP20X](#) [AL3157F-7](#) [AL8807BQMP-13](#) [LV52204MTTBG](#) [TLD1120EL](#) [MP2488DN-LF](#) [MP24893DQ-LF-P](#) [MP24894GJ-P](#) [MP24895GJ-P](#) [MP3308DL-LF-Z](#) [MP3393EF-LF](#) [MP3394SGF](#) [MP3802DQ-LF-P](#) [MP4008GS](#) [MP4031GS](#) [MP4032-1GS](#) [MP4034GS](#) [MP46885DN-LF](#) [SLG7NT4082V](#) [SLG7NT4082VTR](#) [PCA9955BTWQ900J](#) [TLD5095EL](#) [LED6001TR](#) [STP4CMPQTR](#) [BD1604MVV-E2](#) [MAX16832CASAT](#) [MAX16814CATP+](#) [NCL30086BDR2G](#) [NCL30088BDR2G](#) [IS31LT3350-V1SDLS2-EB3CH](#) [MP3202DJ-LF-P](#)