

EX Series Heatsinks

For TO-220 and TO-247 devices and bridge rectifiers

FEATURES

- Vertical through-hole PCB mounting
- E3A-T220-25E has a 8-32 threaded mounting hole for a bridge rectifier in a D34 type square package
- The thickened side fins can be used to secure the heat sink to a side wall or to mount TO-220's
- Threaded mounting holes



SERIES SPECIFICATIONS

Heatsink Part Number	For Package Type	Ohmite Resistor Series	Surface Area (in ² /mm ²)	Weight (oz./g)	Thermal Resistance* (°C/W)
E2A-T220-38E	TO-220	TBH, TCH	7.96 / 5129	0.40 / 11.21	14.0
E2A-T220-25E	TO-220	TBH, TCH	5.30 / 2419	0.26 / 7.5	16.4
E2A-T247-38E	TO-247	TEH100	7.95 / 5129	0.40 / 11.21	14.0
E3A-T220-25E	D34		9.4 / 6064	0.60 / 17.0	12.4

*Natural convection at 5W dissipation

CHARACTERISTICS

Heat sink	Aluminum 6063-T5 or equivalent with either black anodized or degreased finish
Solder feet	steel tin plated
Interface thermal resistance	for improvement, use thermal joint compound or 0.005 Grafoil (TGon 800 by Laird)
Interface electrical isolation	Sil-Pad 900S by Bergquist or equivalent

Heat Dissipation

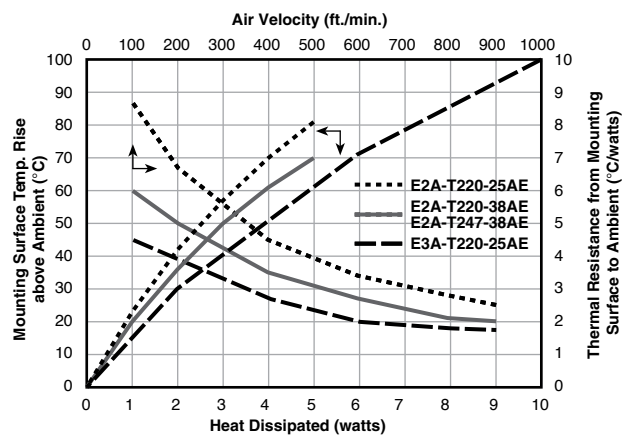

(continued)

EX Series Heatsinks

For TO-220 and TO-247 devices and bridge rectifiers

DIMENSIONS

in. (mm)

E2A-T220-38E

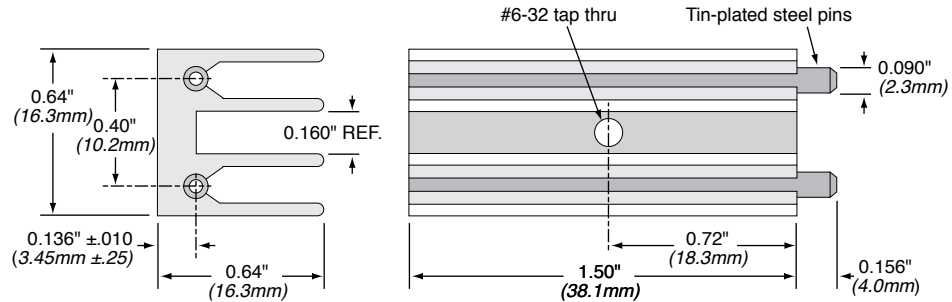

E2A-T220-25E

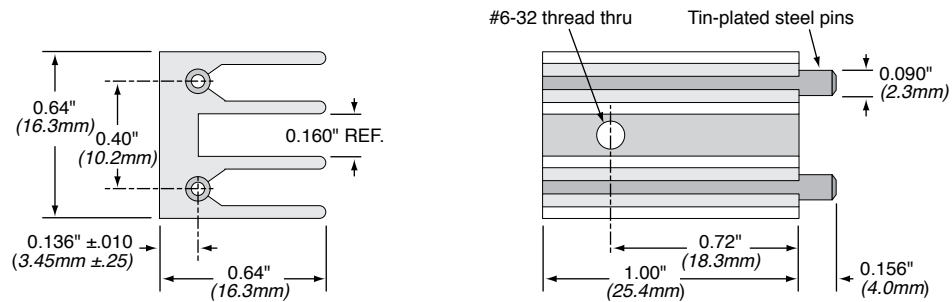

E2A-T247-38E

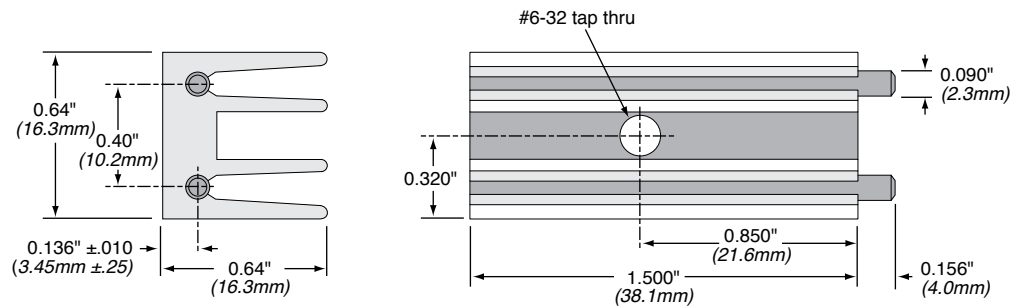

E3A-T220-25E

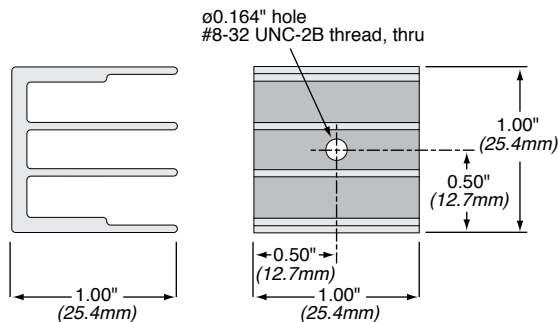

ORDERING INFORMATION

Extrusion type RoHS Compliant
E 2 A - T 2 2 0 - 3 8 E
 Series Finish Package Height
 EX A = anodized type

X-ON Electronics

Largest Supplier of Electrical and Electronic Components

Click to view similar products for [Heat Sinks](#) category:

Click to view products by [Ohmite](#) manufacturer:

Other Similar products are found below :

[581102B00000G](#) [630-35ABT3](#) [656-15ABPE](#) [657-20ABPNE](#) [7020B-TC12-MTG](#) [73452PPBA](#) [7721-13NG](#) [7G0011A](#) [FI306/SE](#) [PF720G](#)
[A22-4026](#) [120-1873-007](#) [HAH10L](#) [HF20](#) [1542256-2](#) [1542026-1](#) [1542616-1](#) [HS-2506-F1](#) [HS-87M0-F2](#) [218-40CTE3](#) [25-7520](#)
[188854F00000G](#) [F-QB-F1](#) [APA501-60-003](#) [253-122ABE-22](#) [PSC22CB](#) [CLP-201](#) [CLP212SG](#) [CLP-7701G](#) [HAA072](#) [HAA083](#) [HAF10L](#)
[HAQ10T](#) [D10100-28](#) [TO5-002D](#) [513101B02500G](#) [BDN183CBA01](#) [531202B0000](#) [HS-56M0-C1](#) [3-21053-4](#) [TX0506-1B](#) [TX1806B](#)
[336614B-00000](#) [V2004X](#) [LAE66A3CB](#) [WA-DT2-101E](#) [511-3U](#) [017177](#) [530510B00000G](#) [6110BG](#)