

HLS-440P

Automotive Hydrogen Leak Sensor

General Description

The HLS-440P automotive hydrogen sensor monitors hydrogen leakage concentrations of 0 - 10% in air. The design fulfills Zone 2 requirements according to ATEX 100a. The predicted concentration is transmitted to the host via the CAN bus interface or with PWM output.

Type A:

The sensor shall measure the hydrogen concentration in high humidity conditions, e.g. in the exhaust of a fuel cell system, to ensure compliance with defined upper thresholds.

Type B:

The sensor shall measure the hydrogen concentration under ambient humidity conditions, to ensure compliance with defined upper thresholds.

Ordering Information and Content Guide appear at end of datasheet.

Key Benefits & Features

The benefits and features of HLS-440P, Automotive Hydrogen Leak Sensor are listed below:

Figure 1:
Added Value of Using HLS-440P

Benefits	Features
<ul style="list-style-type: none"> High sensitivity over large concentration range 	<ul style="list-style-type: none"> 0 – 10% H₂ in air or nitrogen Accuracy ±0.5% vol. Resolution 500ppm
<ul style="list-style-type: none"> Low cross sensitivity 	<ul style="list-style-type: none"> Heated field-effect transistor technology No detection towards HC, H₂S, N₂, CO, CO₂, NO_x
<ul style="list-style-type: none"> Designed for humid environment 	<ul style="list-style-type: none"> Humidity influence <0.5% typical Operating humidity range 5–100% relative humidity including condensation
<ul style="list-style-type: none"> Fast response time 	<ul style="list-style-type: none"> Start-up time <5s Speed of response (t₉₀) < 5s Speed of recovery < 5s CAN bus interface 500 kbit/s (ISO11898-2) PWM output (optional)
<ul style="list-style-type: none"> Low power consumption 	<ul style="list-style-type: none"> 70 mA (typical)
<ul style="list-style-type: none"> Long-term stability and reliability 	<ul style="list-style-type: none"> ESD and EMC protection Operating temperature range –40°C to 90°C Operating pressure range 0.5 – 1.2 bar (absolute)

Benefits	Features
<ul style="list-style-type: none"> • Safety integrity level and explosion proof 	<ul style="list-style-type: none"> • Designed for SIL2 (IEC 61508) and ATEX 100a zone 2
<ul style="list-style-type: none"> • Long lifetime 	<ul style="list-style-type: none"> • IP6K7 and IP6K9K qualified with expected lifetime of 10 years

Applications

Detection of hydrogen gas leaks in fuel cell systems and other in-process applications.

Block Diagram

The functional blocks of this device for reference are shown below:

Figure 2:
HLS-440P Block Diagram

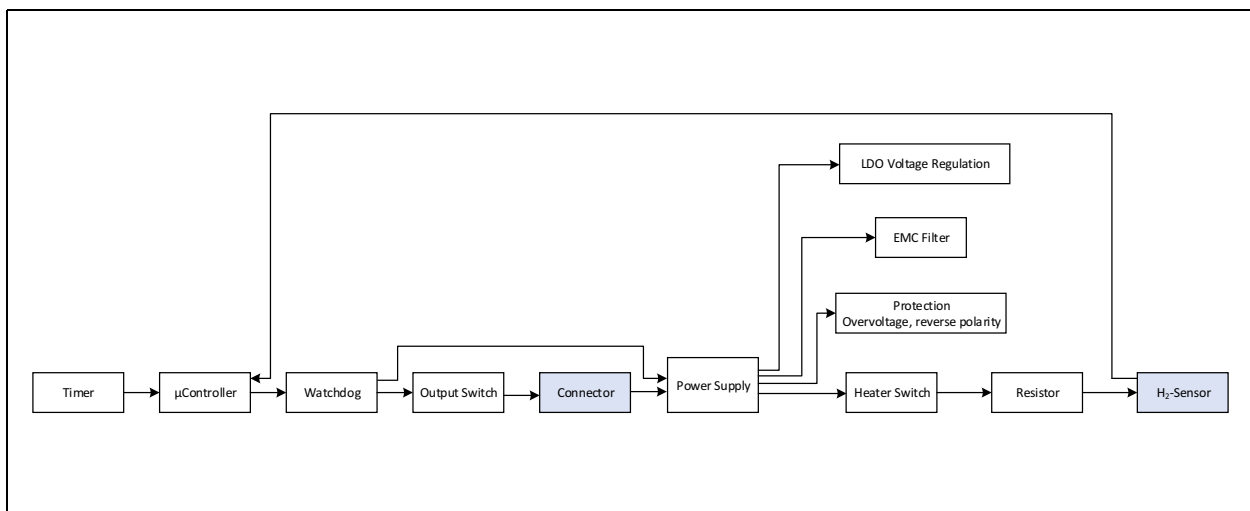

Overview

Figure 3:
HLS-440P Overview



Installation

The HLS-440P is designed for process connection with metric straight screw thread with o-ring M14x1.5 in accordance with ISO 6149-3 (stud end) and to fit into ISO 6149-1 (port).

The HLS-440P can also be mounted on a holder for open-air application.

Recommended O-ring 11.3±0.2, 2.2±0.08 or 11.3±0.2, 2.4±0.08 EPDM 70 "Peroxide crosslinked" or FPM 75 (Viton)

Recommended torque for fixation: 15 Nm (+10% -0%) acc. ISO 6149-3

Recommended orientation of the sensor, see below.

Figure 4:
Recommended Mounting Position of the Sensor

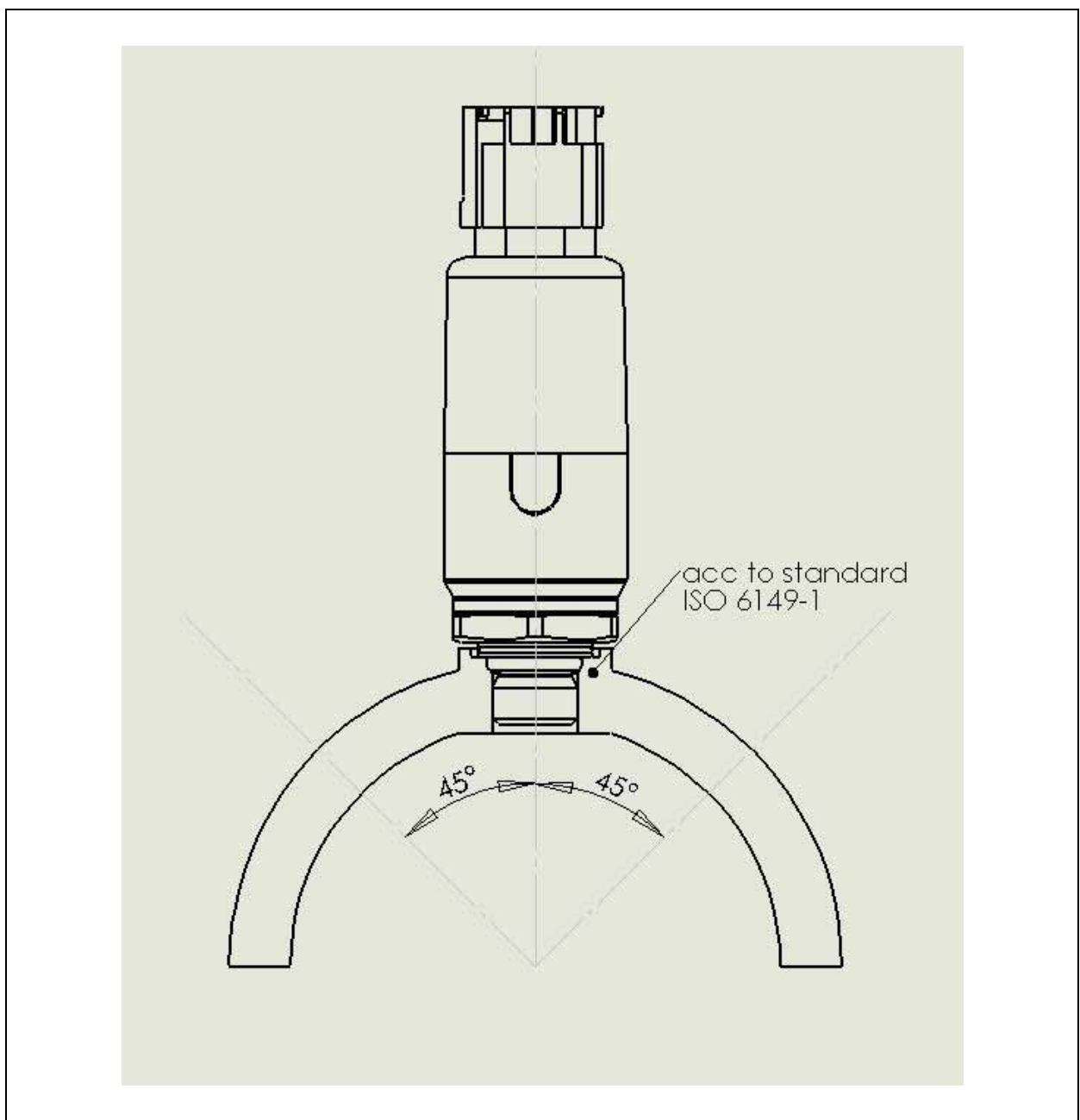

Electrical Interface

Electrical Connector

The sensor connector is a A2105404381 - Code A with mating connector MQS 4-pin, TE Connectivity AMP p/n 1-967640-1 Code A.

Figure 5:
Pin Coding AMP 1-967640-1 Code A



Figure 6:
Pin Assignment

Pin	Function
1	Vcc
2	GND
3	CAN – High Type A with termination resistor Type B no termination resistor
4	CAN – Low Type A with termination resistor Type B no termination resistor

CAN Bus Interface

This section describes the CAN bus interface that is available in some variants of HLS-440P.

Physical Interface

The physical interface is two-wire balanced. It is a high speed CAN interface (ISO 11898-2) with bus bit rate at 500 kbit/s.

Type A: 120 Ohm CAN bus termination

Type B: no termination

CAN Matrix HLS-440P

HLS-440P will send the first CAN message 0.1 s after start-up. The repetition rate of the CAN message is 100ms \pm 2ms. The first H₂ concentration will be delivered after 5 s. The CAN messages prior to that will have the "Not_ready" bit set, indicating that the concentration value of the message is not valid.

In case of a warm restart (<5s) error category 1 will be set for 10 s.

The Msg Counter increments with each CAN message.

Each CAN message is sent twice. The first time it is sent with ID 1592 (0x0638) for type A and 1600 (0x0640) for type B. The second time it is sent with ID 1595 (0x063B) for type A and ID 1603 (0x0643) for type B. The second time all bytes excluding byte 7 are inverted. Byte 7 has the fix value 170 (hex AA) in the second message.

Figure 7:
CAN Matrix Message Layout HLS-440P

System:	H2ES		Receiver						
Name:	A: H2 Exhaust Sensor B: H2 Ambient Sensor			Rev. 3.3					
ID: (hex)	A: 0x638 B: 0x640								
Datalengthcode:	8								
Interrupt:	no								
Transceive:	Tx								
Remote:	no								
Repetition rate:	100 ms								
									MSB

variables	short name	datatype	resolution	phys. range / unit	raw range	no value	b7	b6
H2 Concentration	H2ES_Con	byte	0,05	0 .. 10 Vol.% H2	0 .. 200	255		
Status								
Sensor not ready	H2ES_not_ready	bit						
Error Category	H2ES_Err_Cat	2 bit						
EMC correction active	H2ES_EM_Corr	bit						
negative drift info	H2ES_neg_drift1	bit						
negative drift warning	H2ES_neg_drift2	bit						
negative drift alarm	H2ES_neg_drift3	bit						b6
Error 5		bit					x	
SW Version y.z	H2ES_SW	byte	1	0 .. F . 0 .. F	0.. 255		y	y
HW Version								
Type	H2ES_HW_Type	2 bit	1	0	0		b7	b6
HW revision	H2ES_HW_Rev	6 bit	1	0 .. 63	0 .. 63			
Msg Counter	H2ES_Count	byte	1	0 .. 127	0 .. 127	255		to be increme
Safety Byte - CRC Byte 0 .. Byte 6	H2ES_Safety	byte	1		0.. 255			

Definition Error Category :

Code	Name	Description
0	No Error	H2ES Sensor OK
1	Performance Error	General function still given (e.g. tolerance range may be incre
2	Slight functional error	General function still given but high likelihood for upcoming se
3	Severe functional error	Severe error, general function NOT given anymore, sensor no

Definition HW Version Type :

Code	Name	Type	Description
0	H2ES	Type A	H2 Exhaust Sensor
1	H2AS		H2 Anode Sensor
2	H2S		H2 Ambient Sensor
3	H2ES	Type B	H2 Stack Module Vent Sensor

Byte 0 H₂ Concentration

**Figure 8:
Byte 0 Bit Order**

Bit	MSB 7	6	5	4	3	2	1	LSB 0
Byte 0	X	X	X	X	X	X	X	X

This byte shows the H₂ concentration in a resolution of 0.05.

x = Concentration in % Hydrogen

(EQ1) $\text{Byte value} = (x \% \text{H}_2) * 200 / (10 \% \text{H}_2)$

(EQ2) $x \% = \text{byte value} * (10 \% \text{H}_2) / 200$

Range: 0 - 200 (Hexadecimal 0 - C8)

No value: 255 (Hexadecimal FF)

Values: 0 - 10 % H₂

Resolution: $0.05 = (10 \% \text{H}_2) / 200$

The No value is sent if there is no valid H₂ concentration (accompanied by Not_ready bit in status byte (Byte 1))

Byte 1 Status

**Figure 9:
Byte 1 Status Bit Assignment**

Bit	MSB 7	6	5	4	3	2	1	LSB 0
Byte 1	Bit 7	Bit 6 Neg_ drift3	Bit 5 Neg_ drift2	Bit 4 Neg_ drift1	Bit 3 EMC_ Corr	Bit 2 Err_ Category	Bit 1 Err_ Category	Not_ready

This byte shows the status of the module.

Bit 0: If the not_ready bit is set, the module is not up or not working.

Value: 0 or 1

Bit 1 + 2: The error category

Value: 0 - 3

The figure below describes the error category definition

Figure 10:
Definition of Error Category

Code	Name	Description
0	No error	Sensor OK
1	Performance error	General function still given; Warm start-up indication (<5 s)
2	Slight functional error	General function still given but high likelihood for upcoming severe error (sensor should be replaced)
3	Severe functional error	Severe error, general function NOT given anymore, sensor not longer trustable (=signal not available)

Bit 3: EMC_Corr...EMC correction active

Value: 0 or 1

Bit 4: Negative drift info. If this bit is set, the prediction has gone below the first of three warning levels.

Bit 5: Negative drift warning. If this bit is set, the prediction has gone below the second warning level.

Bit 6: Negative drift alarm. If this bit is set, the prediction has gone below the third warning level.

Bit 7 is not used.

Byte 4 Software Version Y.Z

Figure 11:
Byte 4 Software Version Numbering Code

Bit	MSB 7	6	5	4	3	2	1	LSB 0
Byte 4	Y	Y	Y	Y	X	X	X	X

This byte shows the firmware version.

View: Y.Z

Range: 0 - 255 (Hexadecimal 0 - FF)

Value: 0.0 - 15.15 (Hexadecimal 0.0 - F.F)

Byte 5 Hardware Version

Figure 12:
Byte 5 Hardware Version Numbering Code

Bit	MSB 7	6	5	4	3	2	1	LSB 0
Byte 5	HW Type	HW Type	Rev.	Rev.	Rev.	Rev.	Rev.	Rev.

This byte is divided into two parts. The first part shows the hardware type

Figure 13:
Definition of HW Version Type

Code	Name	Description
0	HLS-440P type A	H ₂ Exhaust Sensor (H2ES Type A)
1	HPS-100	H ₂ Anode Sensor (H2AS)
2		H ₂ Ambient Sensor (H2S)
3	HLS-440P type B	H ₂ Stack Module vent Sensor (H2ES Type B)

Range: 0 - 3 here 0

The second part of byte 5 shows the revision of the hardware.

Range: 0 - 63

Byte 6 Msg Counter

Figure 14:
Byte 6 Message Counter Order

Bit	MSB 7	6	5	4	3	2	1	LSB 0
Byte 6	X	X	X	X	X	X	X	X

The Msg Counter byte numbers the CAN-messages and is incremented by 1 with each (non-inverted) message

Range: 0 - 127 (0 - 7F)

Value: 0 - 127

After reaching the value 127 the counter starts from 0 again.

Byte 7 Safety Byte CRC**Figure 15:
Byte 7 Safety Byte Order**

Bit	MSB 7	6	5	4	3	2	1	LSB 0
Byte 7	X	X	X	X	X	X	X	X

The CRC byte shows the 7-bit CRC over byte 0-6 with the Polynomial 0xE5.

PWM

This section describes the PWM output that is available in some variants of HLS-440P.

Physical Interface

The electrical connector is the same as in the variants with CAN bus interface (see [Electrical Connector](#)). Type A has a termination resistor while type B does not.

The PWM signal is created as a differential CAN signal on pin 3 and 4. A CAN signal is said to be in a dominant state when the signal lines are separated (a dominant bit is transmitted). When the signal lines are at the same voltage level, the state is recessive. Recommended circuitry to convert CAN signals to TTL is specified in a separate document, available on request. The PWM signal is only an output signal. No other transmitting devices should be attached to the bus.

The PWM Signal

The PWM signal has a period time of 255 μ s. The rather short period is chosen since modern CAN transceivers do not allow for a longer dominant state.

The duration of the recessive state can be translated into output H_2 prediction from the sensor module. The recessive duration (pulse width) ranges from 20 to 220 μ s, which corresponds to 0 to 10% hydrogen. An error is shown as a 10 μ s pulse width. At startup the pulse width will be 255 μ s (100% duty cycle) until the first valid H_2 concentration is delivered after 5 s.

The figure below shows the output for 0% hydrogen (pulse width of 20 μ s).

Figure 16:
Sensor Output for 0% Hydrogen (Pulse Width of 20 μs)

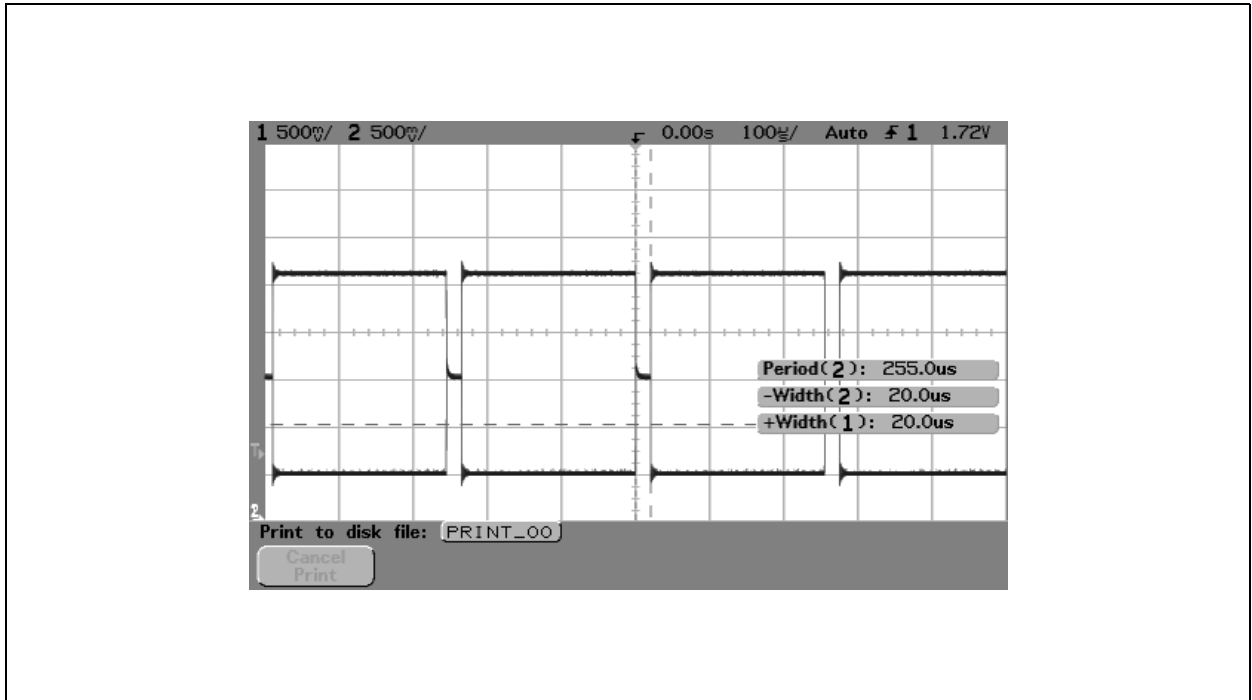

The relation between detected H₂ concentration (in ppm) and pulse width (in μs) is:

$$(EQ3) \quad H_2 = (\text{pulse width} - 20) * 500$$

The figure below shows the relation between H₂ prediction and pulse width.

Figure 17:
The Relation between H₂ Prediction and Pulse Width

Pulse Width	Message Type
10 μs	Error
20 μs	0% H ₂
21 μs	0.05% H ₂
...	...
219 μs	9.95% H ₂
220 μs	10.0% H ₂

Specifications

Figure 18:
Typical Characteristics

Description	Value
Sensor Function	
Target gas	Hydrogen
Concentration range	0 – 10 Vol% H ₂ in air
Accuracy	± 0.5% vol. ⁽¹⁾
Resolution	500 ppm
Speed of response (t ₉₀)	<5 s
Speed of recovery	<5 s
Cross-sensitivity	None towards HC, H ₂ S, N ₂ , CO, CO ₂ , NO _x Humidity correction by subtracting 0.6% for type A ⁽²⁾ Humidity correction by subtracting 0.3% for type B ⁽²⁾
Start-up time	5 s
Expected lifetime	10 years ⁽¹⁾
Safety	
Explosion proof	Designed to fulfill Zone 2 requirements according to ATEX 100a
Self test/Error handling	Yes
Electrical	
Supply voltage	8.5 – 16 V
Supply current	70 mA typical @ 13.8 V and 20 °C, increased current during start-up phase (avg. 200 mA during first 1s)
CAN interface	Version 2.0 ISO 11898
Connector	A2105404381 - Code A
Mating Connector	MQS 4-pin, AMP 1-967640-1 Code A
ESD/Reverse polarity	Yes

Description	Value
Environmental	
Operation temperature range	-40°C to 90°C
Storage temperature range	-50°C to 95°C
Humidity	5 – 100% including condensation ⁽¹⁾
Pressure	0.5 – 1.2 bar(a)
EMC	Automotive requirements
Mechanical	
Dimensions (L, Ø)	L=93.5mm Ø = 30mm
Weight	77g
Stud	M14x1.5 in acc. to ISO 6149-3
O-ring	ID: 11.3 ± 0.2 mm, rec. cord size: 2.2 ± 0.08 mm alt. cord size: 2.4 ± 0.08 mm
Material	Stainless steel and PBT GF30
Filter membrane	Pall SUPOR 450R, 0.45 µm.
IP code	IP6K7 and IP6K9K

Note(s) and/or Footnote(s):

1. Preliminary values
2. Default offset compensation for humidity range.

The figure below describes the specification of the different variants of HLS-440P

Figure 19:
Specification of the Different Variants of HLS-440P

Part Number	Default		On Request	
	A	B	A	B
CAN interface	Version 2.0 ISO 11898		-	
PWM output	-		Yes	
Type	A	B	A	B

Handling Instructions

Due to the fact that the sensor element consists of a silicon chip facing the surrounding the following precautions have to be taken into account:

During storage and handling avoid:

- Humidity (condensing conditions)
- Dropping (sensor must be replaced if dropped)
- Dust (especially if cap is removed)
- Mechanical impact (especially the entrance membrane)
- Electromagnetic radiation (RF fields, high magnetic fields)

In case of storage and transport it is recommended to keep the sensor within its original packaging (plastic cap and ESD protected bubble bag). The disassembly of any parts is not allowed, except for the removal of the plastic cap directly before final assembly.

Reference Data

Figure 20:
Concentration Measurement with H₂ Pulse Width of 2 min and Nominal Concentration 0.2%, 1.5%, 2.5% and 3.5% vol. H₂

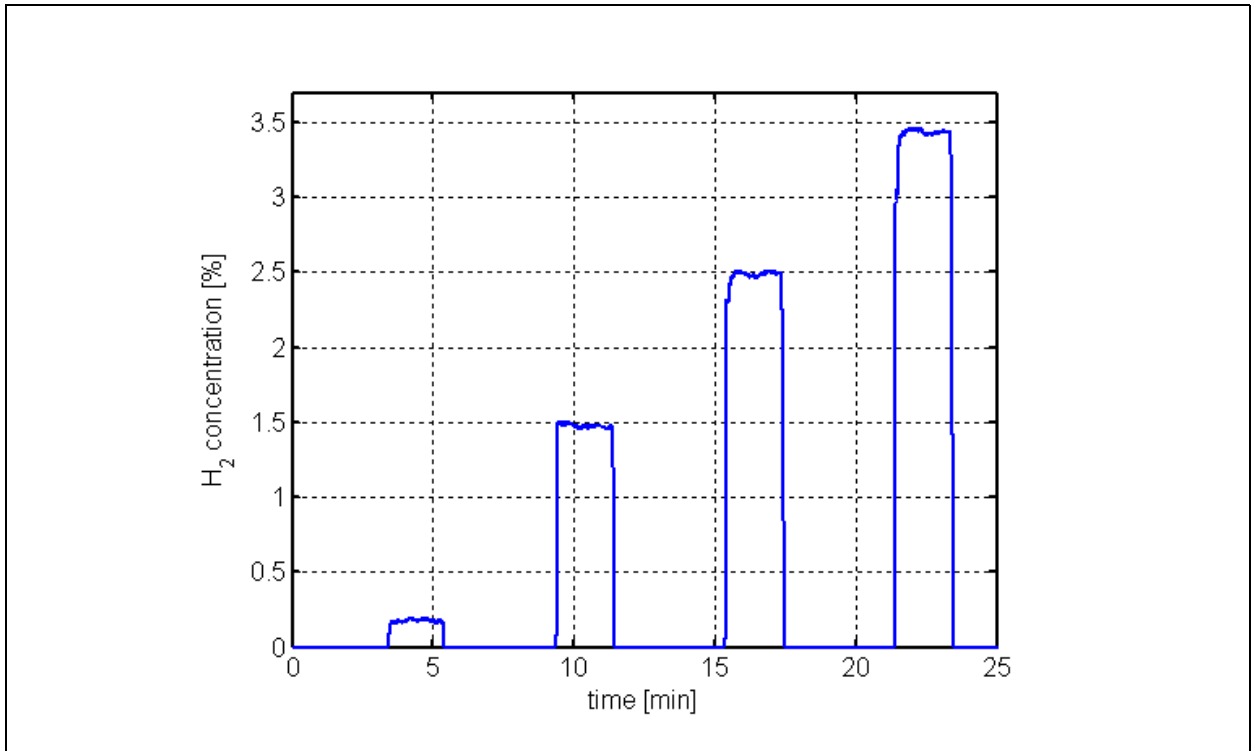
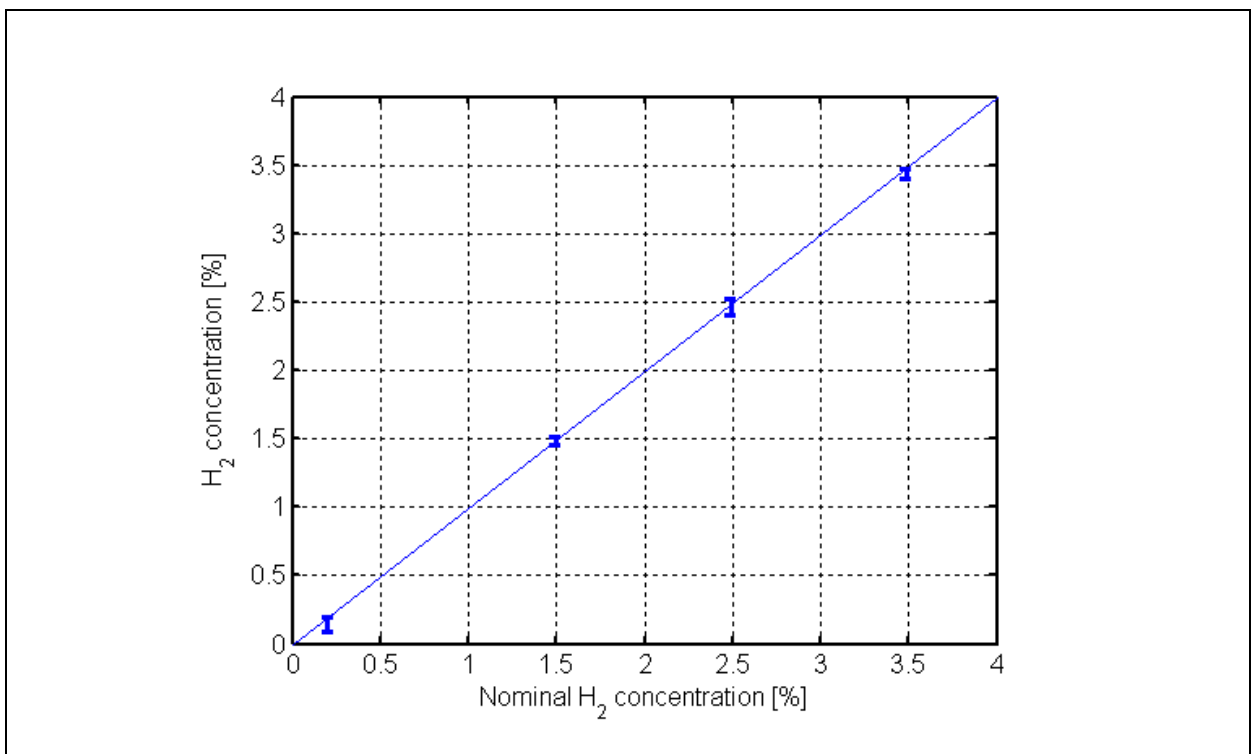

Figure 21:
Deviation of Prediction Over Nominal Concentration



Mechanical Information

Dimensions

Figure 22:
Sensor Dimensions

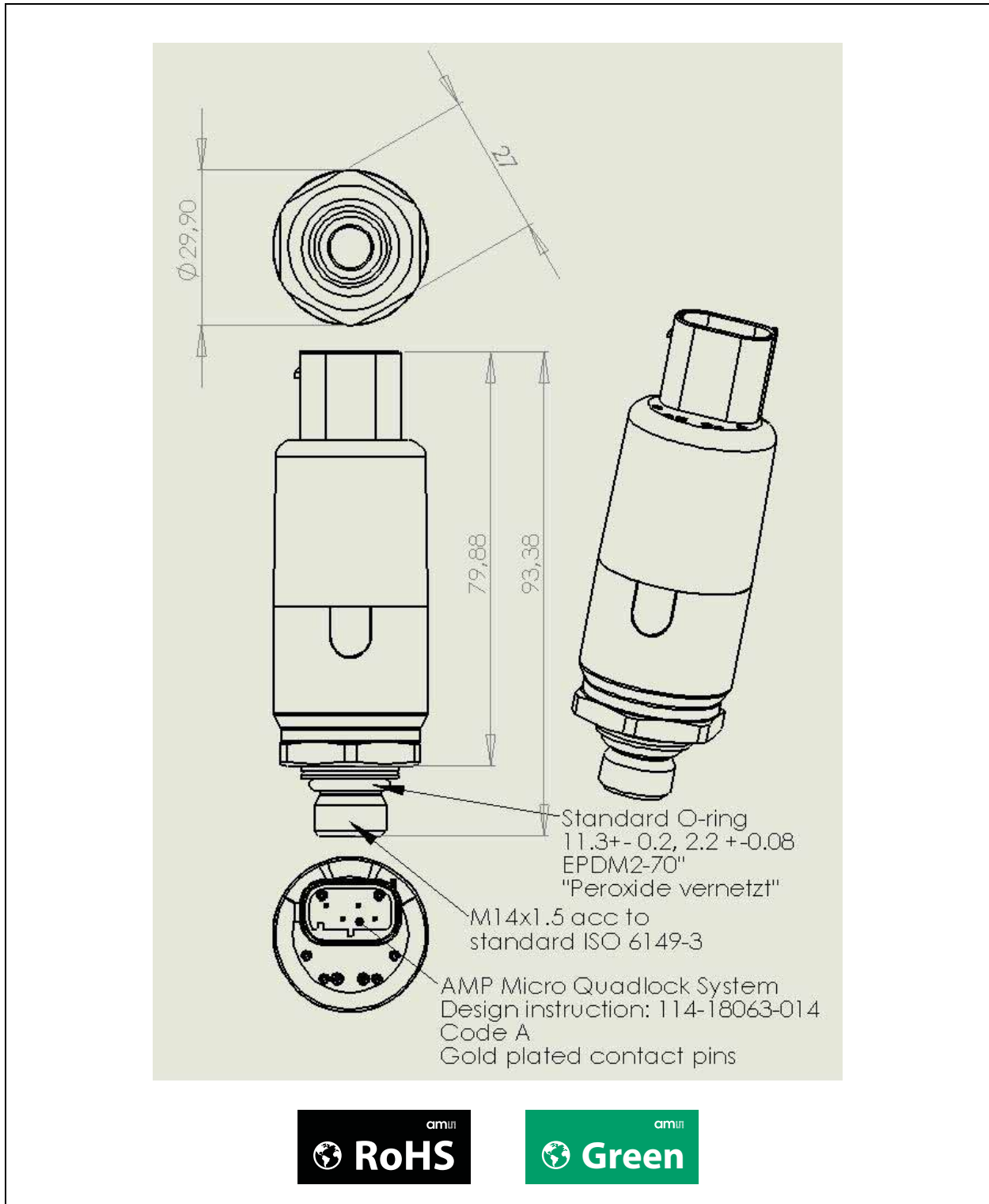

Note(s) and/or Footnote(s):

1. Dimensions are in millimeters.

Ordering & Contact Information

Figure 23:
Ordering Information

Ordering Code	Type	Delivery Form	Delivery Quantity
HLS-440P A ⁽¹⁾	CAN (500 kbit/s) ⁽³⁾	Individually Wrapped	Single Item
HLS-440P B ⁽²⁾	CAN (500 kbit/s) ⁽³⁾	Individually Wrapped	Single Item

Note(s) and/or Footnote(s):

1. High humidity conditions.
2. Ambient humidity conditions.
3. For availability of other variants contact **ams**.

Buy our products or get free samples online at:

www.ams.com/ICdirect

Technical Support is available at:

www.ams.com/Technical-Support

Provide feedback about this document at:

www.ams.com/Document-Feedback

For further information and requests, e-mail us at:

ams_sales@ams.com

For sales offices, distributors and representatives, please visit:

www.ams.com/contact

Headquarters

ams AG
Tobelbaderstrasse 30
8141 Unterpremstaetten
Austria, Europe

Tel: +43 (0) 3136 500 0

Website: www.ams.com

RoHS Compliant & ams Green Statement

RoHS: The term RoHS compliant means that ams AG products fully comply with current RoHS directives. Our semiconductor products do not contain any chemicals for all 6 substance categories, including the requirement that lead not exceed 0.1% by weight in homogeneous materials. Where designed to be soldered at high temperatures, RoHS compliant products are suitable for use in specified lead-free processes.

ams Green (RoHS compliant and no Sb/Br): ams Green defines that in addition to RoHS compliance, our products are free of Bromine (Br) and Antimony (Sb) based flame retardants (Br or Sb do not exceed 0.1% by weight in homogeneous material).

Important Information: The information provided in this statement represents ams AG knowledge and belief as of the date that it is provided. ams AG bases its knowledge and belief on information provided by third parties, and makes no representation or warranty as to the accuracy of such information. Efforts are underway to better integrate information from third parties. ams AG has taken and continues to take reasonable steps to provide representative and accurate information but may not have conducted destructive testing or chemical analysis on incoming materials and chemicals. ams AG and ams AG suppliers consider certain information to be proprietary, and thus CAS numbers and other limited information may not be available for release.

Copyrights & Disclaimer

Copyright ams AG, Tobelbader Strasse 30, 8141 Unterpremstaetten, Austria-Europe. Trademarks Registered. All rights reserved. The material herein may not be reproduced, adapted, merged, translated, stored, or used without the prior written consent of the copyright owner.

Devices sold by ams AG are covered by the warranty and patent indemnification provisions appearing in its General Terms of Trade. ams AG makes no warranty, express, statutory, implied, or by description regarding the information set forth herein. ams AG reserves the right to change specifications and prices at any time and without notice. Therefore, prior to designing this product into a system, it is necessary to check with ams AG for current information. This product is intended for use in commercial applications. Applications requiring extended temperature range, unusual environmental requirements, or high reliability applications, such as military, medical life-support or life-sustaining equipment are specifically not recommended without additional processing by ams AG for each application. This product is provided by ams AG "AS IS" and any express or implied warranties, including, but not limited to the implied warranties of merchantability and fitness for a particular purpose are disclaimed.

ams AG shall not be liable to recipient or any third party for any damages, including but not limited to personal injury, property damage, loss of profits, loss of use, interruption of business or indirect, special, incidental or consequential damages, of any kind, in connection with or arising out of the furnishing, performance or use of the technical data herein. No obligation or liability to recipient or any third party shall arise or flow out of ams AG rendering of technical or other services.

Document Status

Document Status	Product Status	Definition
Product Preview	Pre-Development	Information in this datasheet is based on product ideas in the planning phase of development. All specifications are design goals without any warranty and are subject to change without notice
Preliminary Datasheet	Pre-Production	Information in this datasheet is based on products in the design, validation or qualification phase of development. The performance and parameters shown in this document are preliminary without any warranty and are subject to change without notice
Datasheet	Production	Information in this datasheet is based on products in ramp-up to full production or full production which conform to specifications in accordance with the terms of ams AG standard warranty as given in the General Terms of Trade
Datasheet (discontinued)	Discontinued	Information in this datasheet is based on products which conform to specifications in accordance with the terms of ams AG standard warranty as given in the General Terms of Trade, but these products have been superseded and should not be used for new designs

Revision Information

Changes from (2014-Dec) to current revision 1-00 (2015-Apr-01)	Page
Content of Applied Sensor datasheet was updated to the latest ams design	

Note(s) and/or Footnote(s):

1. Page and figure numbers for the previous version may differ from page and figure numbers in the current revision.
2. Correction of typographical errors is not explicitly mentioned.

Content Guide

1	General Description
1	Key Benefits & Features
2	Applications
2	Block Diagram
3	Overview
4	Installation
5	Electrical Interface
5	Electrical Connector
6	CAN Bus Interface
6	Physical Interface
6	CAN Matrix HLS440P
7	<i>Byte 0 H2_Concentration</i>
8	<i>Byte 1 Status</i>
9	<i>Byte 4 Software Version Y.Z</i>
9	<i>Byte 5 Hardware Version</i>
10	<i>Byte 6 Msg Counter</i>
10	<i>Byte 7 Safety byte CRC</i>
11	PWM
11	Physical Interface
11	The PWM Signal
13	Specifications
15	Handling Instructions
16	Reference Data
17	Mechanical Information
17	Dimensions
18	Ordering & Contact Information
19	RoHS Compliant & ams Green Statement
20	Copyrights & Disclaimer
21	Document Status
22	Revision Information

X-ON Electronics

Largest Supplier of Electrical and Electronic Components

Click to view similar products for [Air Quality Sensors](#) category:

Click to view products by [ams](#) manufacturer:

Other Similar products are found below :

[GMS-MSTH2.S.V.3](#) [MO86571](#) [MO86561](#) [595001074420009](#) [076074 01](#) [DE800.A.1](#) [MF010-2-LC1](#) [MF020-2-LC3](#) [KGZ10-5PIN](#)
[GMS10SENSORS](#) [IR25TT](#) [208280-0001](#) [LIS3MDL](#) [3-AXIS MAGNETOMETER CARRIER](#) [SS-BME280#I2C](#) [SS-BMP280#I2C](#) [SS-CCS811#I2C](#) [SS-HDC2010+CCS811#I2C](#) [SS-HDC2010#I2C](#) [GMS10-18C](#) [KGZ12](#) [INIR-RF-R290](#) [INIR-RF-R32](#) [MODBUS-RS485](#)
[114991728](#) [114991732](#) [COLORPAL](#) [MR003-001.2](#) [MIKROE-1628](#) [SEN0162](#) [T6713-6H](#) [FXTH8709026T1](#) [POLOLU-1482](#) [MF010-0-LC4](#)
[MF010-0-LC3](#) [ELEC DIT.V.1](#) [GP2Y0D02YK0F](#) [803P602](#) [ZS-510-B](#) [1201148022](#) [1201190004](#) [1201148023](#) [DE800.V.1](#) [D5VM-3P1](#) [E3X-MC11](#) [EE-SPZ301](#) [XS5FD421G80A](#) [SGAS701](#) [SGAS711](#) [HPMA115S0-XXX](#) [T3032-2-5K-24-P](#)