

| SYMBOL DEFINITION | | MISSING SYMBOLS | |
|---|----------------------------------|--------------------------|----|
| A DIMENSION WITHOUT AN INSPECTION REPORT SYMBOL () OR () DOES NOT REQUIRE INSPECTION. IT MAY BE CONTROLLED ON THE INDIVIDUAL COMPONENT DRAWING. | TOTAL NO OF INSPECTIONS REQUIRED | NO MISSING SYMBOL NUMBER | 15 |
| () INDICATES THE DIMENSION IS SHOWN ON THE PART DRAWING AND THE TOOL MUST BE QUALIFIED AT 80% OF THE TOLERANCE SHOWN UNLESS SUPERSEDED BY A "TBT". | LAST NO. USED | | 14 |

| DWG STATUS | | | | REVISION HISTORY | | | | AUTH | | |
|------------|-----|-----|------|------------------|------|--|--|------|--|--------|
| DATE | STG | REV | CHKD | N/P | ZONE | | | | | |
| 01SE00 | R | B2 | - | - | | | | | | 202052 |

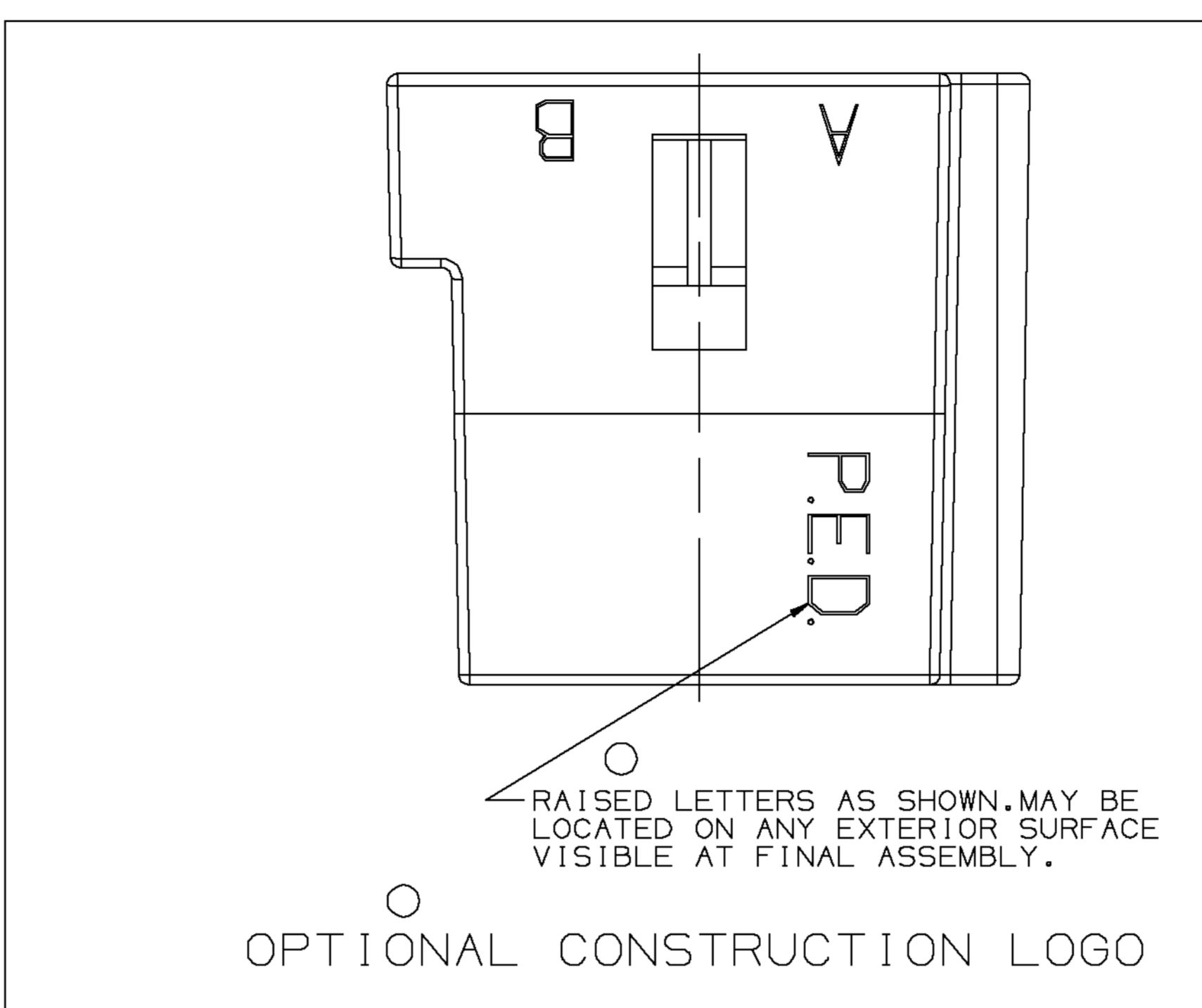

○ RAISED LETTERS AS SHOWN, MAY BE LOCATED ON ANY EXTERIOR SURFACE VISIBLE AT FINAL ASSEMBLY.

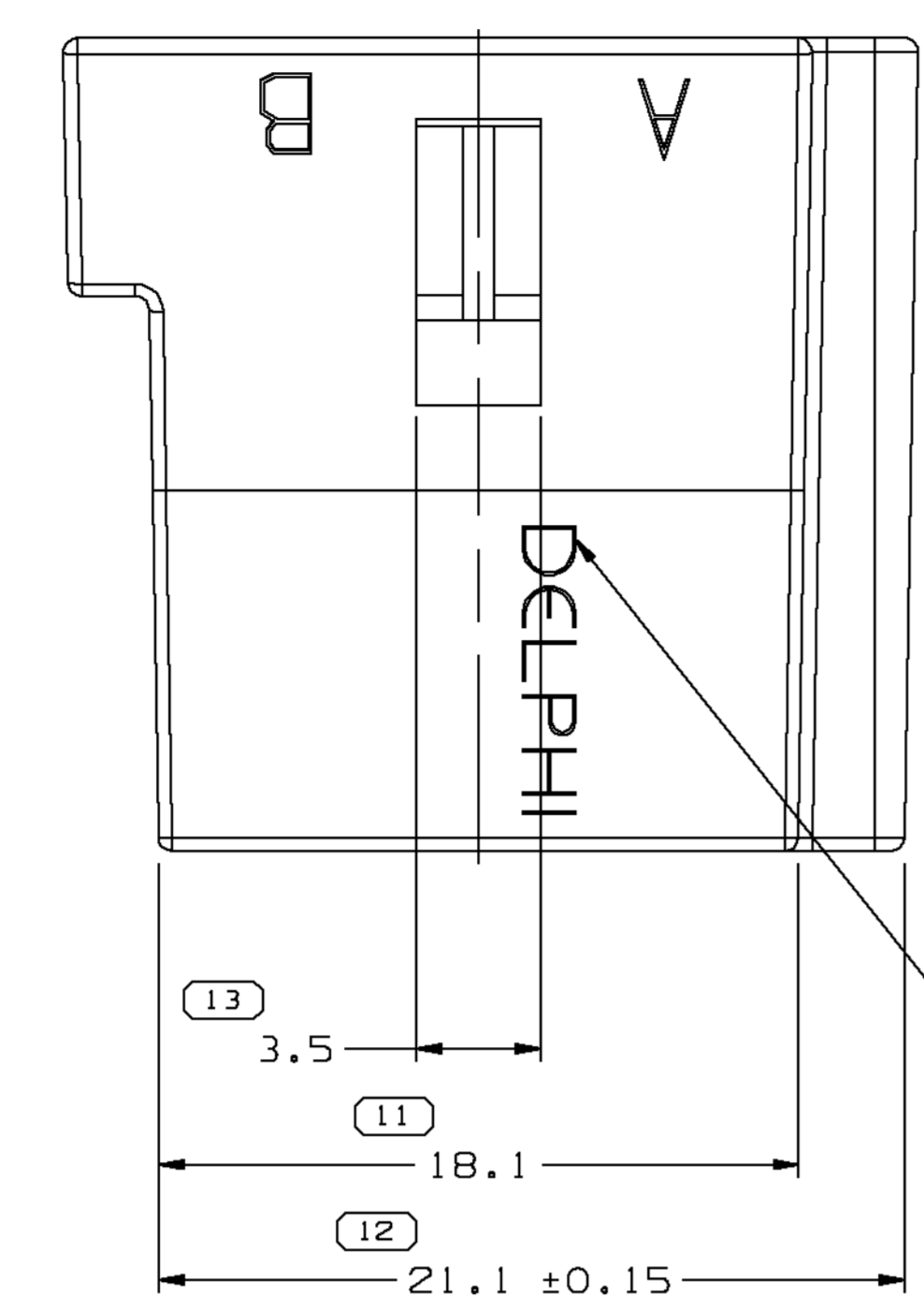
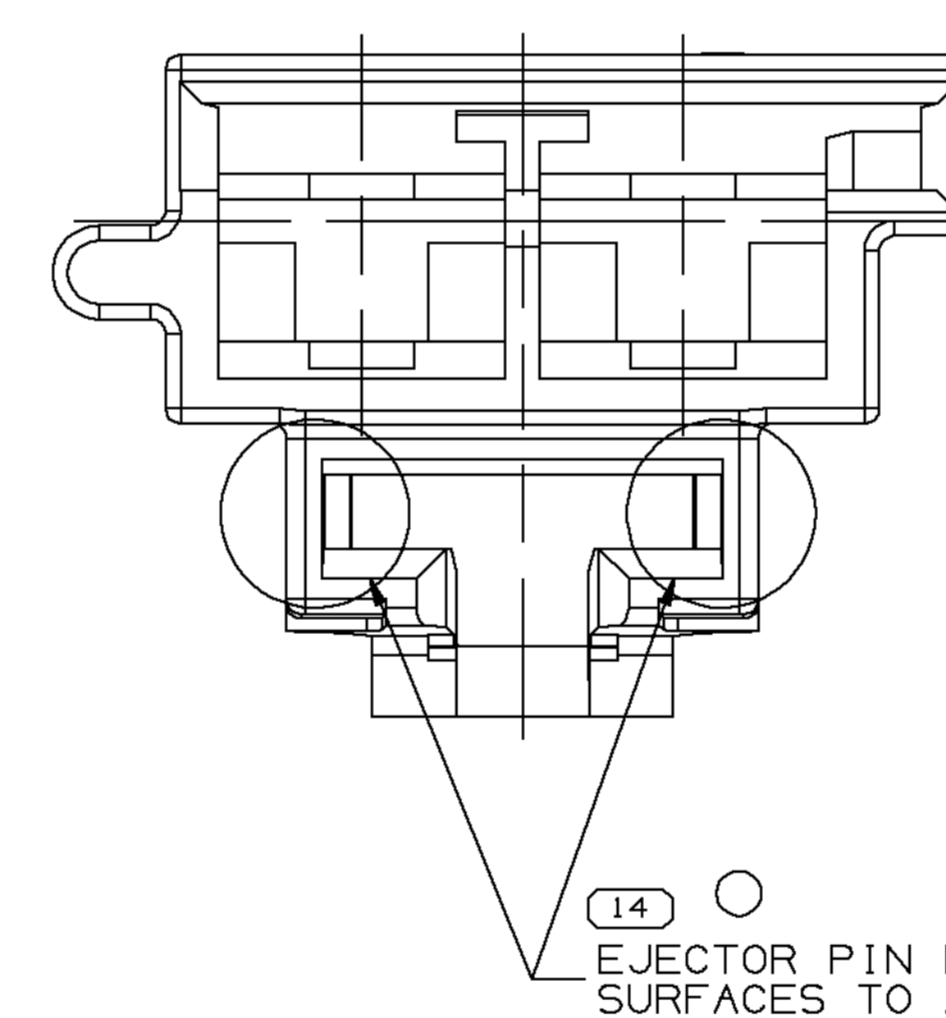
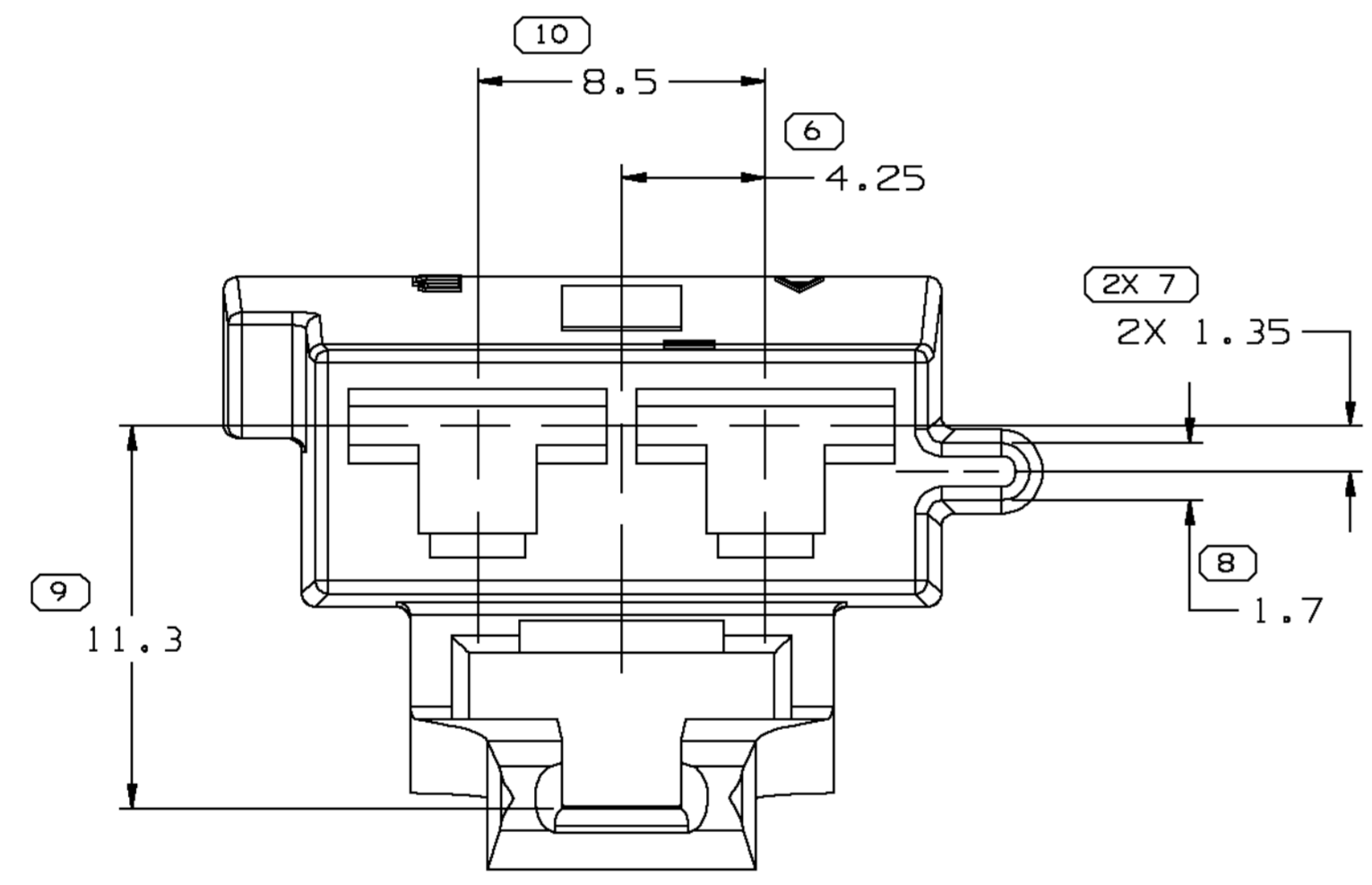
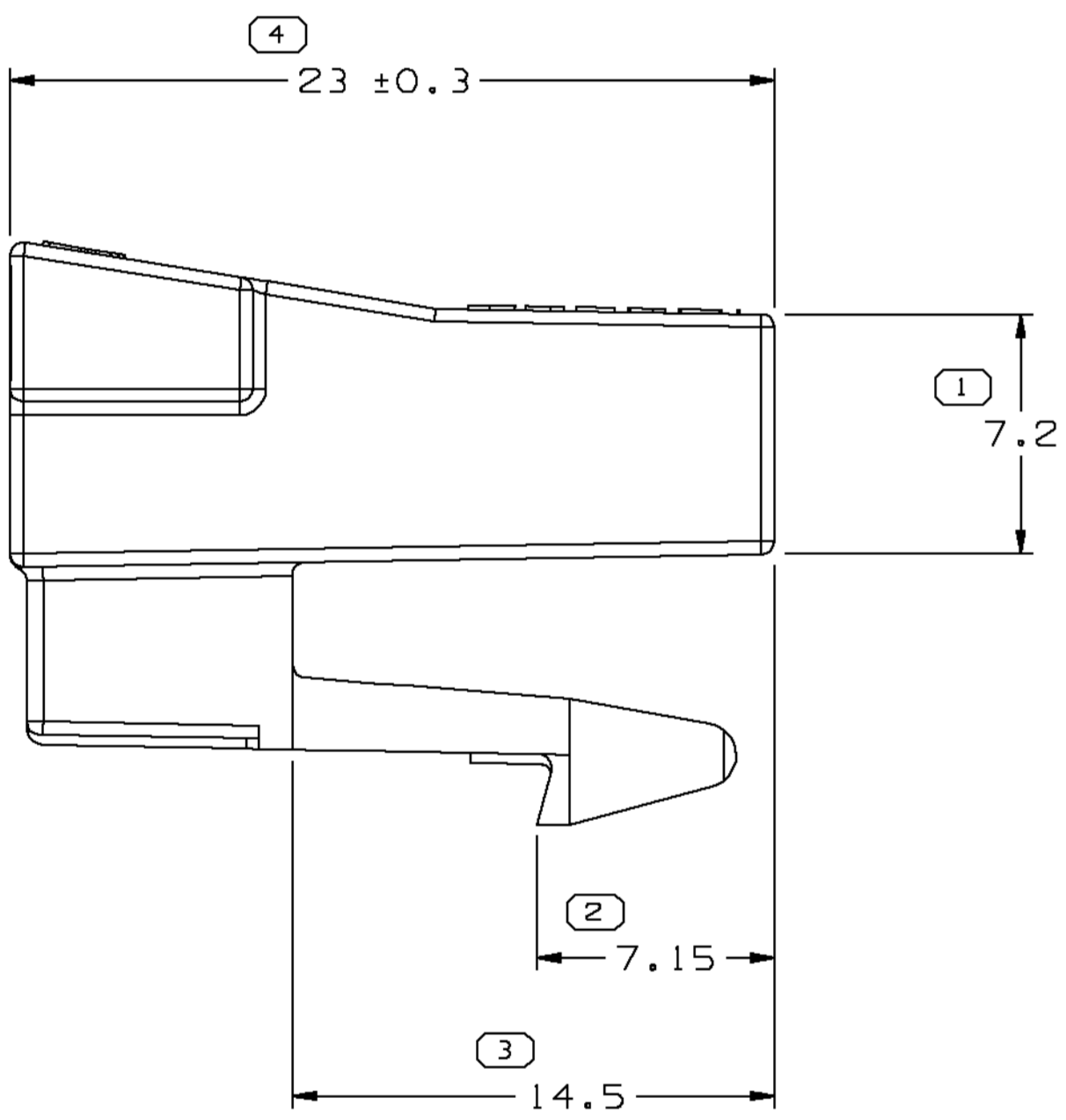

○ EJECTOR PIN MARKS ALLOWABLE ON THESE SURFACES TO A MAXIMUM DEPTH OF 0.65MM.

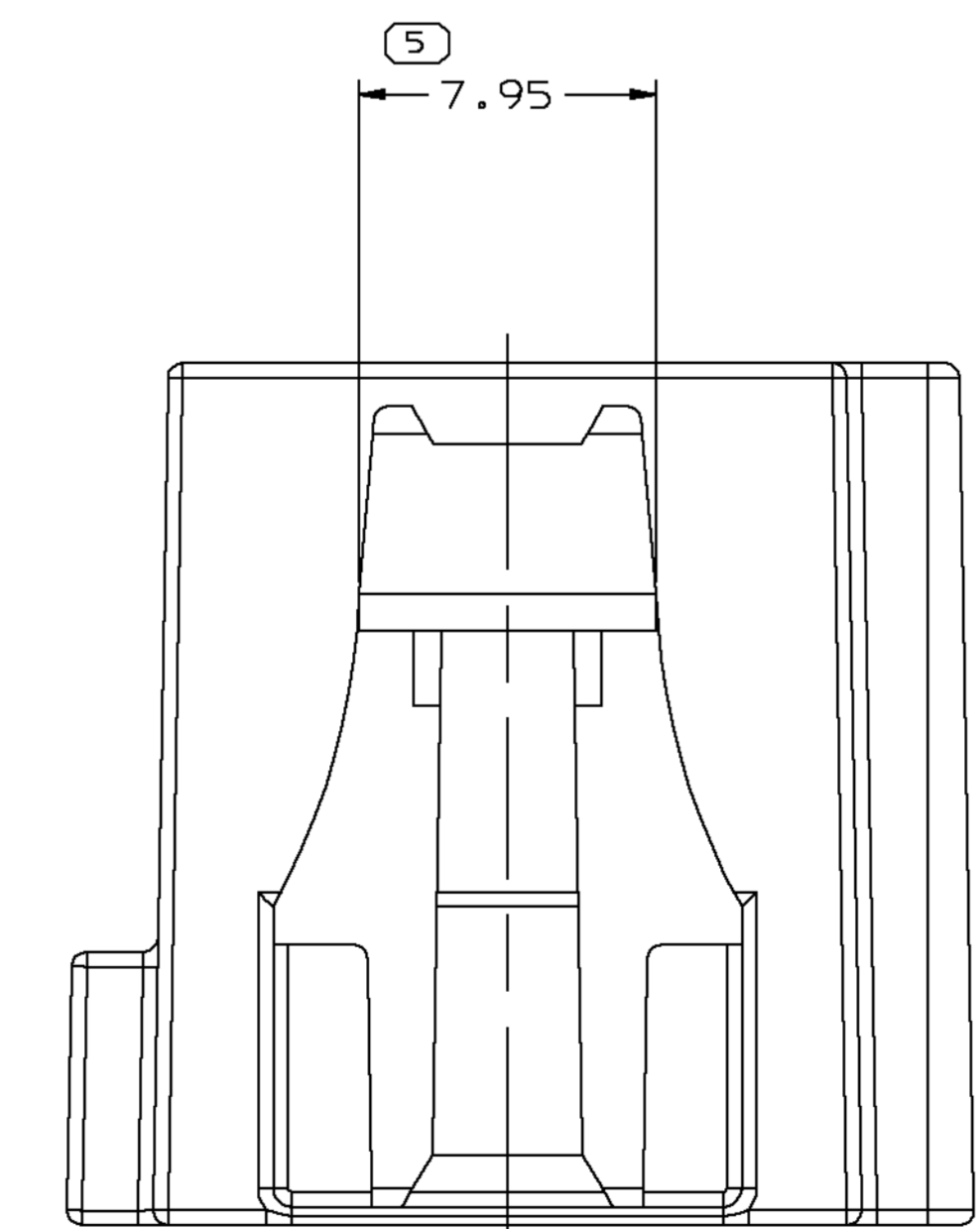

NOTES

- UNLESS OTHERWISE SPECIFIED AND/OR INDICATED: DIMENSIONS ARE TO FACE OF VIEW SHOWN AND AUTOMATICALLY ROUNDED BY COMPUTER FOR INSPECTION (SEE MATH MODEL FOR PRECISE DIMENSIONS). FOR ALL OTHER DIMENSIONS NOT SHOWN BUT REQUIRED FOR TOOL BUILD, SEE MATH MODEL FOR PRECISE TOOL PATH DATA.
- MATING COMPONENTS OR EQUIVALENT: CONNECTOR 12129938
- THIS PART ACCEPTS THE FOLLOWING COMPONENTS OR EQUIVALENT: CAVITIES A & B TO ACCEPT 12015869 TERMINAL MAX INSULATION CRIMP MUST BE LESS THAN 5.5 MM HIGH AND 7.45 MM WIDE. SECONDARY TERMINAL LOCK 12129940 CONNECTOR POSITION ASSURANCE LOCK 12052834

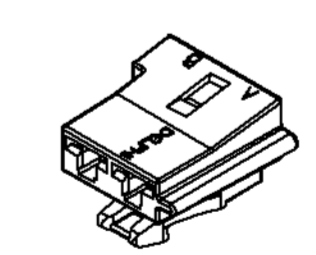

| | |
|---|---|
| DELPHI Automotive Systems | |
| MATERIAL SPEC R0071754 PA66 HS 1M-BLK | |
| SUBSTANCES OF CONCERN AND RECYCLED CONTENT PER DELPHI-A 10949001 | |
| PART DRAWING | |
| CODE NUMBER 6900 | DWG DATE 26MR92 |
| OC SPEC | SCALE 5:1 |
| | VOLUME cm³ 2.152 |
| PART GEOMETRY 3D SOLID | UNLESS OTHERWISE SPECIFIED: THIS DOCUMENT IS IN ACCORDANCE WITH ASME Y14.5M - 1994 AS AMENDED BY THE GM GLOBAL DIMENSIONING AND TOLERANCING ADDENDUM - 1997. ALL GEOMETRIC TOLERANCES AND RELATED DATUMS APPLY RFS. RULE #1 (PERFECT FORM AT MMC) DOES NOT APPLY WHEN RELATIONSHIP BETWEEN FEATURES IS ESTABLISHED BY ORIENTATION OR LOCATION TOLERANCES. SEPARATE POSITION CALLOUTS MAY BE GAGED SEPARATELY REGARDLESS OF DATUM REFERENCES. |
| CHANGE RESTRICTED NO MANUAL CHANGES | REFERENCE |
| COPY OF MATH DATA DO NOT SCALE | DR APVD1 J. GAVALDON 28AU00 APVD2 E. VAZQUEZ 01SE00 APVD3 J. HORIUCHI 05SE00 APVD4 APVD5 |
| METRIC UNLESS OTHERWISE SPECIFIED, ALL DIMENSIONS ARE IN MILLIMETERS | DATE |
| THIRD ANGLE PROJECTION | DRAWING NAME CONN 2F M/P 630 |

| | |
|--------------------------------------|--|
| (12) PROCESS SENSITIVE DIMENSION | INDICATE REFLECTING DIMENSIONS AND NO TOLERANCE LIMITS ARE ESTABLISHED |
| DIMENSIONAL RANGE (MM) | CHART E1 |
| FROM TO | 0 > 20 > 30 > 70 > 100 > 150 > 200 > 250 > 300 > 400 |
| TOLERANCE UNLESS OTHERWISE SPECIFIED | ±0.15 ±0.2 ±0.3 ±0.4 ±0.5 ±0.6 ±0.8 ±1 ±1.2 |
| ANGULAR TOLERANCE | ± 2 |

| | | | |
|------------------------|----------------------------|----------------------|------------|
| SHEET NUMBER 1 OF 1 | DRAWING NUMBER 12129939 | DWG STATUS R B2 - | SIZE A0 |
|------------------------|----------------------------|----------------------|------------|

X-ON Electronics

Largest Supplier of Electrical and Electronic Components

Click to view similar products for [Automotive Connectors](#) category:

Click to view products by [Delphi](#) manufacturer:

Other Similar products are found below :

[003-018-000](#) [600858](#) [60403001](#) [60993906-B](#) [60993913-B](#) [629515004020001](#) [M902-2131](#) [M902-2161](#) [M902-2344](#) [72.330.1035.1](#)
[73.353.4028.0](#) [F118010](#) [F119300-B](#) [F132210](#) [F132210-B](#) [F166900](#) [F180100](#) [F258300](#) [F258300-B](#) [F294300-B](#) [F339100](#) [F339700](#) [F358300-](#)
[B](#) [F374110](#) [F407400](#) [F412210](#) [F427600](#) [F444110](#) [F487000](#) [F495100-B](#) [F500900-B](#) [F509500B-B](#) [770444-1](#) [776880-1](#) [827153-1](#) [881735-1](#)
[8N1515-32-24P](#) [9-1326727-8](#) [9-1326729-8](#) [925467-1](#) [925474-1](#) [928905-1](#) [936398-2](#) [964562-1](#) [964562-4](#) [964731-2](#) [965051-1](#) [968782-1](#)
[GT17SA-8DS-HU](#) [GT17VS-10DP-5.2CF](#)