

## Miniature Bottom Port Analog MEMS Microphone

### Features

- High acoustic overload point (AOP, 124-dB SPL)
- High signal-to-noise ratio (63-dB SNR)
- Low variation in sensitivity ( $\pm 1$  dB)
- Low current consumption (55  $\mu$ A)
- Analog output
- Bottom-port LGA package
- 1.6- to 3.6-V supply

### Description

The CS7331P is a low-profile analog MEMS microphone. It offers miniature dimensions and low-current consumption, making it ideal for always-on, always-listening use in space-constrained applications.

The CS7331P incorporates Cirrus Logic® proprietary CMOS/MEMS membrane technology, offering high reliability and high performance. The CS7331P is designed to withstand the high temperatures associated with automated flow solder assembly processes.

The CS7331P is ideally suited to the Cirrus Logic SoundClear™ suite of audio processing algorithms, including speech recognition, voice trigger, and noise cancelation.

The CS7331P is available in a 2.5 × 1.6 × 0.9-mm, bottom-port LGA package, with a 0.25-mm port diameter. It is ideal for portable applications such as noise-canceling earbuds, smartphones, wearables, and cameras.

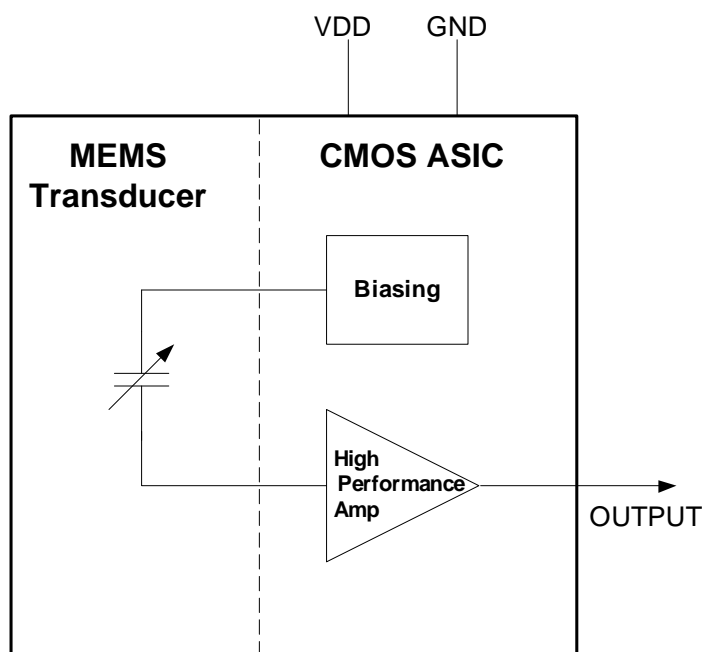

---

**Table of Contents**

<b>1 Pin Descriptions</b> .....	<b>3</b>
1.1 LGA Pinout .....	3
1.2 Pin Descriptions .....	3
<b>2 Typical Connection Diagram</b> .....	<b>4</b>
<b>3 Characteristics and Specifications</b> .....	<b>4</b>
Table 3-1. Parameter Definitions .....	4
Table 3-2. Recommended Operating Conditions .....	4
Table 3-3. Absolute Maximum Ratings .....	5
Table 3-4. Acoustic and Electrical Characteristics .....	5
<b>4 Typical Performance</b> .....	<b>6</b>
<b>5 Applications Information</b> .....	<b>7</b>
5.1 Important Assembly Guidelines .....	7
5.2 PCB Land Pattern and Paste Stencil .....	8
<b>6 Package Dimensions</b> .....	<b>9</b>
<b>7 Ordering Information</b> .....	<b>9</b>
<b>8 References</b> .....	<b>9</b>
<b>9 Revision History</b> .....	<b>9</b>

## 1 Pin Descriptions

### 1.1 LGA Pinout

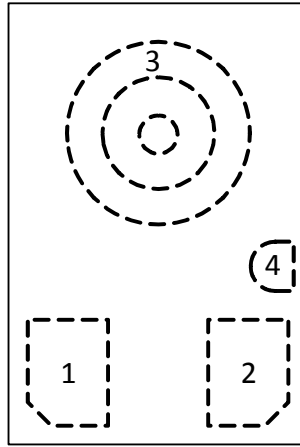

Figure 1-1. Top-Down (Through-Package) View

### 1.2 Pin Descriptions

A description of each pin on the CS7331P is provided in [Table 1-1](#).

Table 1-1. Pin Descriptions

Name	Pin #	I/O	Description
VDD	1	—	Power supply
OUTPUT	2	O	Microphone analog output signal
GND	3	—	Ground
GND	4	—	Can be left floating (recommended), or connected to GND

## 2 Typical Connection Diagram

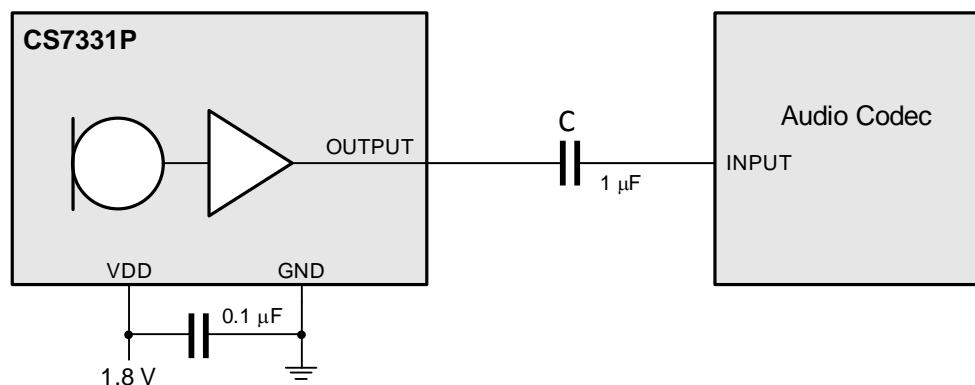

**Figure 2-1. Typical Connection Diagram**

The recommended connection of a CS7331P silicon microphone is shown in [Fig. 2-1](#).

A DC-blocking capacitor is required on the OUTPUT pin. The capacitor must be correctly selected as it affects the cut-off frequency of the output path. A low cut-off frequency is desirable to ensure there is no significant filtering of the audio bandwidth.

The 3-dB cut-off frequency of the output path can be calculated using [Eq. 2-1](#), where  $C$  is the output capacitance and  $R$  is the input resistance of the audio codec.

$$\text{3-dB filter cut-off frequency} = \frac{1}{2\pi RC}$$

**Equation 2-1. Low-Pass Filter Calculation**

A typical recommended configuration uses a 1- $\mu\text{F}$  DC-blocking capacitor and a 20-k $\Omega$  codec input impedance, which results in a 3-dB cut-off frequency of 10 Hz or less. Tantalum electrolytic capacitors are particularly suitable for the DC-blocking components as they offer high stability in a small package size.

It is also recommended to place a 0.1- $\mu\text{F}$  decoupling capacitor close to the VDD pin of the CS7331P.

## 3 Characteristics and Specifications

**Table 3-1. Parameter Definitions**

Parameter	Definition
Sensitivity	A measure of the microphone output response to the acoustic pressure of a 1-kHz, 94 dB SPL (1 Pa RMS) sine wave.
Total harmonic distortion (THD)	The ratio of the RMS sum of the harmonic distortion products in the specified bandwidth (see note) relative to the RMS amplitude of the fundamental (i.e., test frequency) output.
Signal-to-noise ratio (SNR)	A measure of the difference in level between the output response of a 1-kHz, 94 dB SPL sine wave and the idle noise output.
Dynamic Range (DR)	The ratio of the 10% THD microphone output level (in response to a sine wave input) and the idle noise output.

**Note:** Unless otherwise specified, all performance measurements are specified with a 20-kHz, low-pass brick-wall filter and, where noted, an A-weighted filter. The low-pass filter removes out-of-band noise.

**Table 3-2. Recommended Operating Conditions**

Parameter	Symbol	Min	Typ	Max	Units
Analog supply range	VDD	1.6	1.8	3.6	V
Ground	GND	—	0	—	V
Operating temperature range	T <sub>A</sub>	-40	—	+85	°C

**Table 3-3. Absolute Maximum Ratings**

Absolute maximum ratings are stress ratings only. Permanent damage to the device may be caused by continuously operating at or beyond these limits. Device functional operating limits and guaranteed performance specifications are given under electrical characteristics at the test conditions specified.

Parameter	Symbol	Min	Max	Units
Supply voltage <sup>1</sup>	VDD	-0.3	4.2	V
Operating temperature range	T <sub>A</sub>	-40	+105	°C
Storage temperature prior to soldering	T <sub>Stgp</sub>	—	30	°C
Storage relative humidity prior to soldering	RH <sub>Stgp</sub>	—	60	%
Storage temperature after soldering	T <sub>Stg</sub>	-40	+105	°C



ESD-sensitive device. The CS7331P is manufactured on a CMOS process. It is therefore generically susceptible to damage from excessive static voltages. Proper ESD precautions must be taken during handling and storage of this device. This device is qualified to current JEDEC ESD standards

1. All voltages are measured with respect to GND.

**Table 3-4. Acoustic and Electrical Characteristics**

Test conditions (unless specified otherwise): GND = 0 V; voltages are with respect to ground; performance data taken with VDD = 1.8 V, R<sub>L</sub> = 10 k $\Omega$ , C<sub>L</sub> = 100 pF, T<sub>A</sub> = +25°C, 55  $\pm$  15% RH; 1 kHz test signal.

Parameter <sup>1</sup>	Min	Typ	Max	Units
Directivity	Omnidirectional			—
Polarity	Positive sound pressure			—
Sensitivity	-39	-38	-37	dBV
Acoustic overload	THD < 10%	124	—	dB SPL
THD	94 dB SPL	0.04	—	%
	114 dB SPL	0.3	—	%
	120 dB SPL	1	—	%
SNR	A-weighted	63	—	dB
DR	A-weighted	93	—	dB
Acoustic noise floor	A-weighted	31	—	dB SPL
Electrical noise floor	A-weighted	-101	—	dBV
PSRR (with respect to VDD)	217 Hz sine wave, 100 mV (peak-peak)	62	—	dB
PSR (with respect to VDD)	217 Hz square wave, 100 mV (peak-peak)	-88	—	dBV
Frequency response	-3 dB low frequency	85	—	Hz
	+3 dB high frequency	15	—	kHz
Frequency response flatness	200 Hz–7 kHz	-1	+1	dB
Part-to-part phase matching	80–100 Hz	—	$\pm$ 10	°
	200 Hz	—	$\pm$ 5	°
Current consumption	—	55	60	$\mu$ A
Output DC impedance	—	200	400	$\Omega$

1. All performance measurements are specified with a 20-kHz, low-pass brick-wall filter and, where noted, an A-weighted filter. The low-pass filter removes out-of-band noise.

## 4 Typical Performance

Test conditions (unless specified otherwise): VDD = 1.8 V, GND = 0 V, R<sub>L</sub> = 10 kΩ, C<sub>L</sub> = 100 pF; 1 kHz test signal.

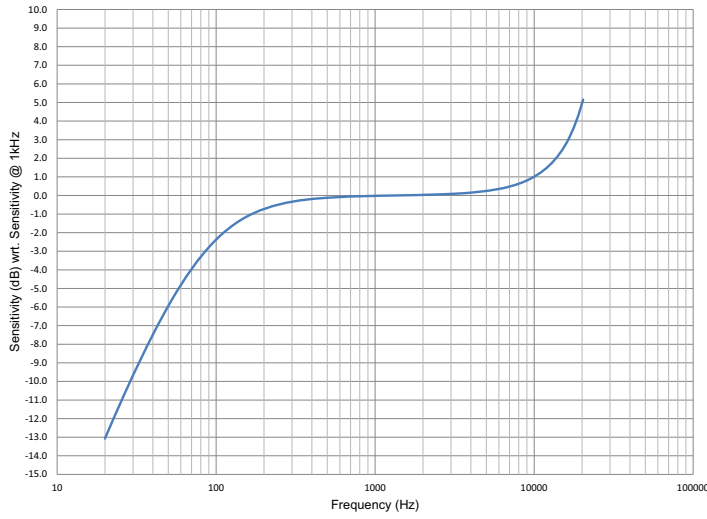

**Figure 4-1. Sensitivity vs. Audio Frequency (20 Hz–20 kHz)**

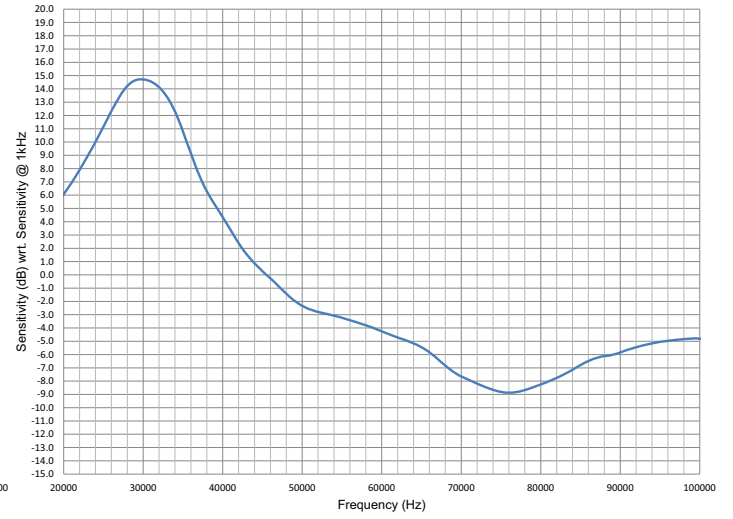

**Figure 4-2. Sensitivity vs. Ultrasonic Frequency (20 kHz–100 kHz)**

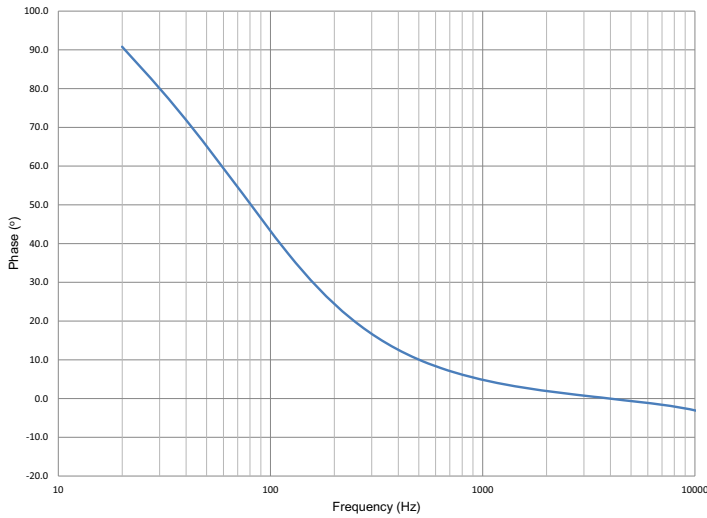

**Figure 4-3. Phase Response vs. Frequency (20 Hz–10 kHz)**

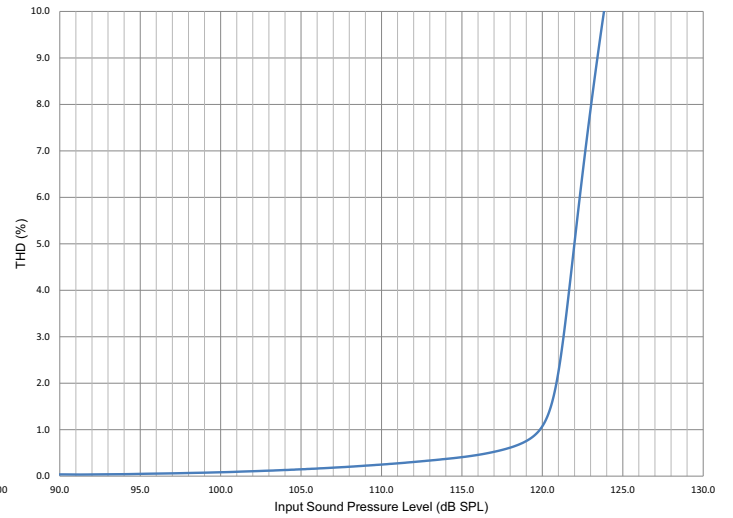

**Figure 4-4. THD (%) vs. Input Sound Pressure Level (dB SPL)**

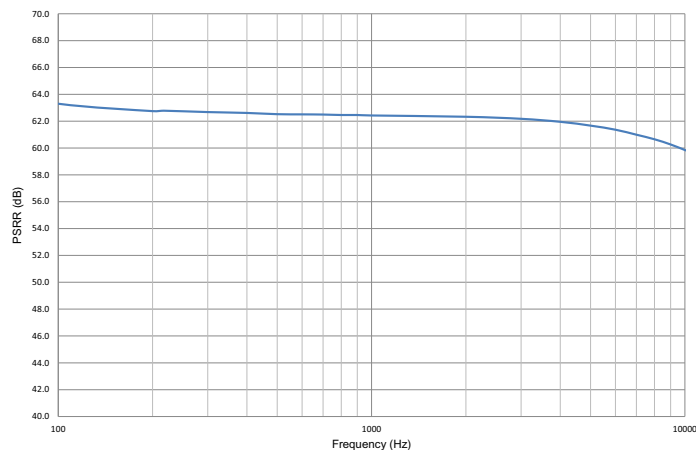

**Figure 4-5. PSRR (dB) vs. Frequency (100 Hz–10 kHz)**

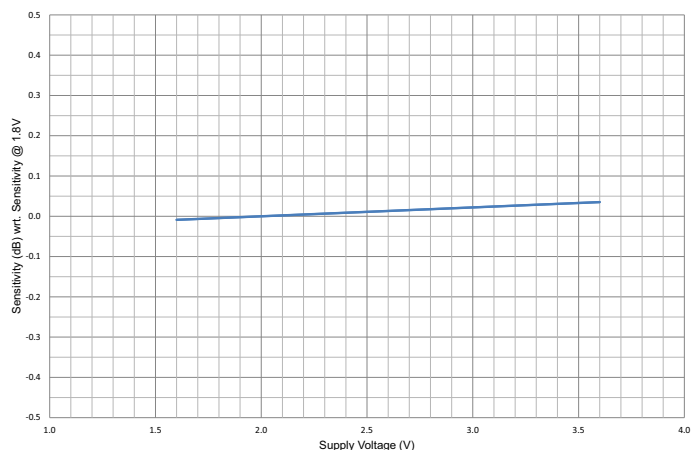

**Figure 4-6. Sensitivity vs. Supply Voltage**

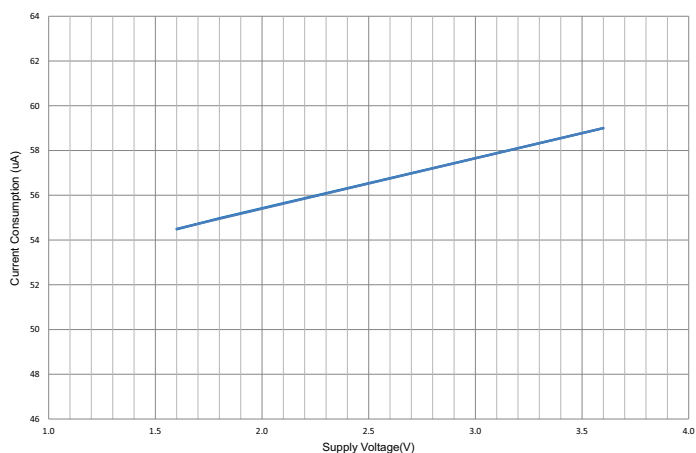

**Figure 4-7. Current Consumption vs. Supply Voltage**

## 5 Applications Information

Cirrus Logic provides a range of audio codecs incorporating an analog microphone input interface. These codecs support direct connections to silicon microphones such as the CS7331P.

Further information on Cirrus Logic audio codecs is provided in the respective product data sheet, which is available from the Cirrus Logic website.

### 5.1 Important Assembly Guidelines

- Do not put a vacuum over the port hole of the microphone. Placing a vacuum over the port hole can damage the device.
- Do not board wash the microphone after a reflow process. Board washing and the associated cleaning agents can damage the device.
- Do not expose to ultrasonic cleaning methods.
- Do not use a vapor phase reflow process. The vapor can damage the device.
- Please refer to application note *WAN0273 MEMS Mic Assembly and Handling Guidelines* for further assembly and handling guidelines.

## 5.2 PCB Land Pattern and Paste Stencil

The recommended PCB Land Pattern and Paste Stencil Pattern for the CS7331P microphone are shown in [Fig. 5-1](#) and [Fig. 5-2](#) respectively.

Note that no connection to Pin 4 should be made on the PCB. To avoid accidental connection to Pin 4, it is recommended to ensure there are no exposed tracks, vias, or copper areas beneath Pin 4.

See also application note [WAN0284 General Design Considerations for MEMS Microphones](#) for further details of PCB footprint design. Full definition of the package dimensions is provided in [Section 6](#).

The recommended PCB Land Pattern is shown in [Fig. 5-1](#).

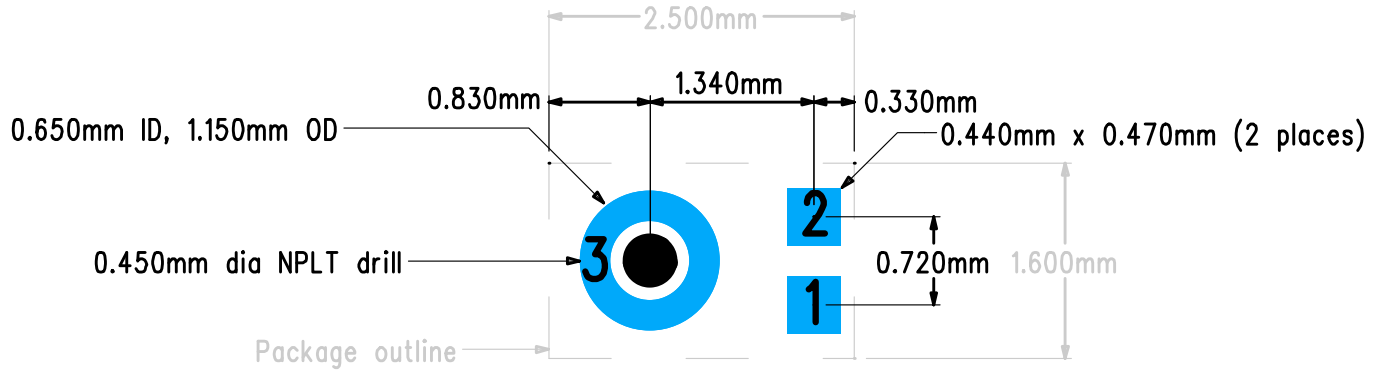

**Figure 5-1. PCB Land Pattern, Top View**

The recommended PCB Paste Stencil Pattern is shown in [Fig. 5-2](#).

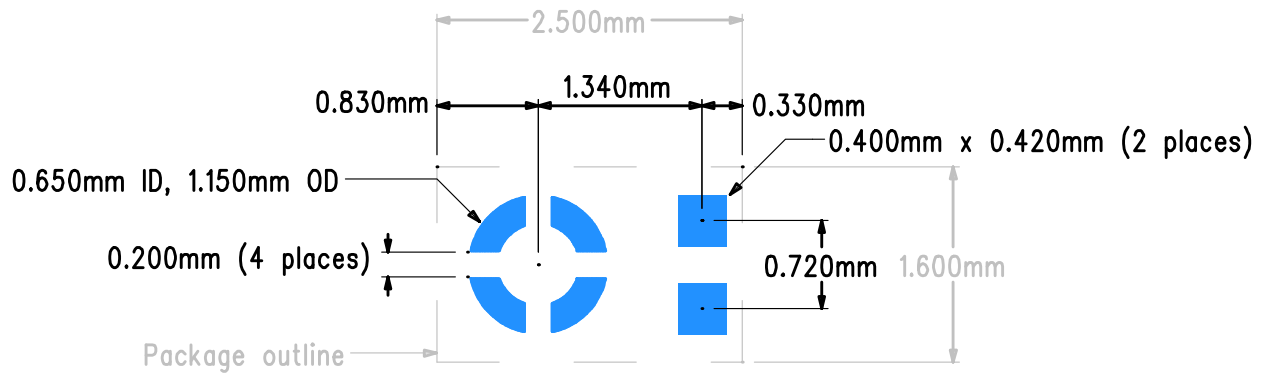

**Figure 5-2. PCB Paste Stencil, Top View**



## 6 Package Dimensions

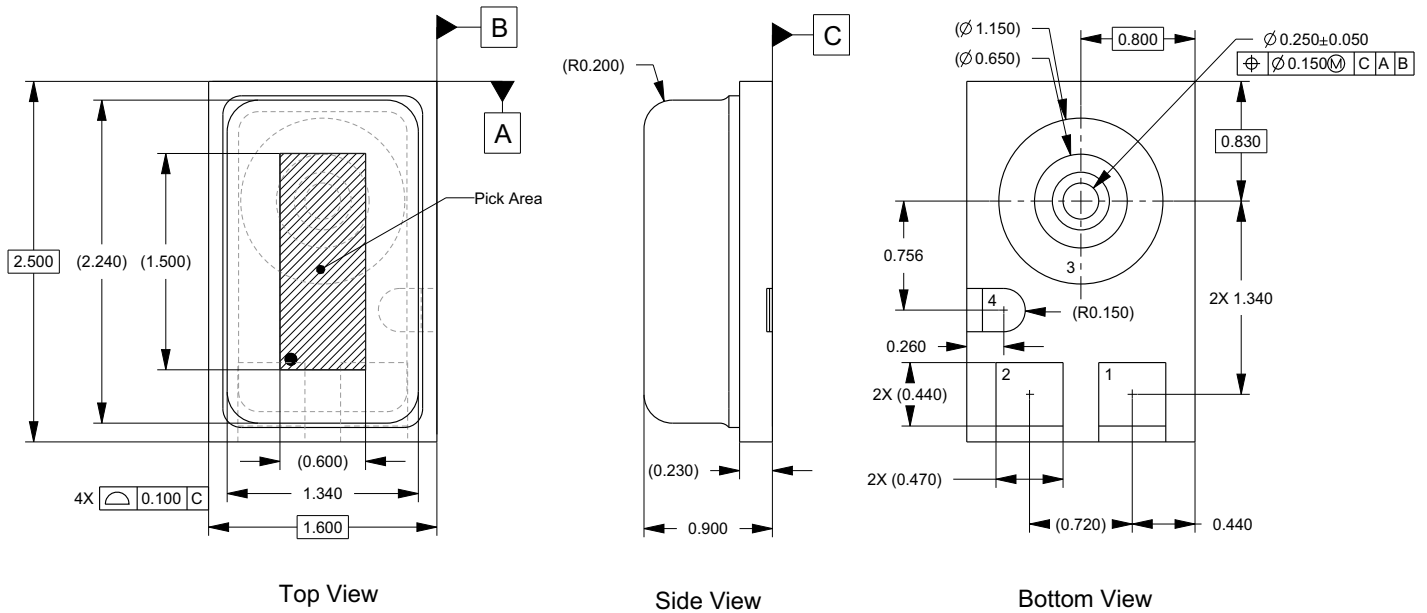

Unless otherwise specified, dimensions/tolerances are in millimeters and tolerance is  $\pm 0.100$

## 7 Ordering Information

Table 7-1. Ordering Information

Product	Description	Package	Halogen Free	Pb Free	Grade	Temperature Range	Container	Order #
CS7331P	Miniature Bottom Port Analog MEMS Microphone	LGA	Yes	Yes	Commercial	-40 to +85°C	Tape and Reel <sup>1</sup>	CS7331P-CAZR

1. Reel quantity = 6,000 units.

## 8 References

- WAN0273 MEMS Mic Assembly and Handling Guidelines
- WAN0284 General Design Considerations for MEMS Microphones

## 9 Revision History

Table 9-1. Revision History

Revision	Changes
F1 MAR '17	• Current consumption and sensitivity performance plots added (Fig. 4-6, Fig. 4-7).

---

## Contacting Cirrus Logic Support

For all product questions and inquiries, contact a Cirrus Logic Sales Representative.

To find the one nearest you, go to [www.cirrus.com](http://www.cirrus.com).

---

### IMPORTANT NOTICE

The products and services of Cirrus Logic International (UK) Limited; Cirrus Logic, Inc.; and other companies in the Cirrus Logic group (collectively either "Cirrus Logic" or "Cirrus") are sold subject to Cirrus Logic's terms and conditions of sale supplied at the time of order acknowledgment, including those pertaining to warranty, indemnification, and limitation of liability. Software is provided pursuant to applicable license terms. Cirrus Logic reserves the right to make changes to its products and specifications or to discontinue any product or service without notice. Customers should therefore obtain the latest version of relevant information from Cirrus Logic to verify that the information is current and complete. Testing and other quality control techniques are utilized to the extent Cirrus Logic deems necessary. Specific testing of all parameters of each device is not necessarily performed. In order to minimize risks associated with customer applications, the customer must use adequate design and operating safeguards to minimize inherent or procedural hazards. Cirrus Logic is not liable for applications assistance or customer product design. The customer is solely responsible for its selection and use of Cirrus Logic products. Use of Cirrus Logic products may entail a choice between many different modes of operation, some or all of which may require action by the user, and some or all of which may be optional. Nothing in these materials should be interpreted as instructions or suggestions to choose one mode over another. Likewise, description of a single mode should not be interpreted as a suggestion that other modes should not be used or that they would not be suitable for operation. Features and operations described herein are for illustrative purposes only.

CERTAIN APPLICATIONS USING SEMICONDUCTOR PRODUCTS MAY INVOLVE POTENTIAL RISKS OF DEATH, PERSONAL INJURY, OR SEVERE PROPERTY OR ENVIRONMENTAL DAMAGE ("CRITICAL APPLICATIONS"). CIRRUS LOGIC PRODUCTS ARE NOT DESIGNED, AUTHORIZED OR WARRANTED FOR USE IN PRODUCTS SURGICALLY IMPLANTED INTO THE BODY, AUTOMOTIVE SAFETY OR SECURITY DEVICES, NUCLEAR SYSTEMS, LIFE SUPPORT PRODUCTS OR OTHER CRITICAL APPLICATIONS. INCLUSION OF CIRRUS LOGIC PRODUCTS IN SUCH APPLICATIONS IS UNDERSTOOD TO BE FULLY AT THE CUSTOMER'S RISK AND CIRRUS LOGIC DISCLAIMS AND MAKES NO WARRANTY, EXPRESS, STATUTORY OR IMPLIED, INCLUDING THE IMPLIED WARRANTIES OF MERCHANTABILITY AND FITNESS FOR PARTICULAR PURPOSE, WITH REGARD TO ANY CIRRUS LOGIC PRODUCT THAT IS USED IN SUCH A MANNER. IF THE CUSTOMER OR CUSTOMER'S CUSTOMER USES OR PERMITS THE USE OF CIRRUS LOGIC PRODUCTS IN CRITICAL APPLICATIONS, CUSTOMER AGREES, BY SUCH USE, TO FULLY INDEMNIFY CIRRUS LOGIC, ITS OFFICERS, DIRECTORS, EMPLOYEES, DISTRIBUTORS AND OTHER AGENTS FROM ANY AND ALL LIABILITY, INCLUDING ATTORNEYS' FEES AND COSTS, THAT MAY RESULT FROM OR ARISE IN CONNECTION WITH THESE USES.

This document is the property of Cirrus Logic and by furnishing this information, Cirrus Logic grants no license, express or implied, under any patents, mask work rights, copyrights, trademarks, trade secrets or other intellectual property rights. Any provision or publication of any third party's products or services does not constitute Cirrus Logic's approval, license, warranty or endorsement thereof. Cirrus Logic gives consent for copies to be made of the information contained herein only for use within your organization with respect to Cirrus Logic integrated circuits or other products of Cirrus Logic, and only if the reproduction is without alteration and is accompanied by all associated copyright, proprietary and other notices and conditions (including this notice). This consent does not extend to other copying such as copying for general distribution, advertising or promotional purposes, or for creating any work for resale. This document and its information is provided "AS IS" without warranty of any kind (express or implied). All statutory warranties and conditions are excluded to the fullest extent possible. No responsibility is assumed by Cirrus Logic for the use of information herein, including use of this information as the basis for manufacture or sale of any items, or for infringement of patents or other rights of third parties. Cirrus Logic, Cirrus, the Cirrus Logic logo design, and SoundClear are among the trademarks of Cirrus Logic. Other brand and product names may be trademarks or service marks of their respective owners.

Copyright © 2016–2017 Cirrus Logic, Inc. All rights reserved.

## X-ON Electronics

Largest Supplier of Electrical and Electronic Components

*Click to view similar products for [MEMS Microphones](#) category:*

*Click to view products by [Cirrus](#) manufacturer:*

Other Similar products are found below :

[8103AC8333S25.00000X](#) [SPK0838HT4H-1](#) [MMICT4076-00-908](#) [MMICT4078-00-908](#) [MMICT3902-00-012](#) [1007079-1](#) [TA-35.328MBD-T](#)  
[TC-106.250MBD-T](#) [TD-22.5792MCD-T](#) [ASFLM1-25.000MHZ-C](#) [5000AC-8E-25E0-25.000000X](#) [3807ACTC3-33EG-8.19200](#)  
[501AAA27M0000CAF](#) [TC-133.330MBD-T](#) [TC-38.400MBD-T](#) [TD-6.000MCD-T](#) [XX7V1A1PAM12](#) [9120AI-2C3-25E100.0000](#)  
[MP34DB01TR](#) [8002AI-13-33E16.00000](#) [5001AI-2D-18N0-20.000000](#) [UC2000-30GM-IUR2-V15](#) [MM034202-1](#) [INMP621ACEZ-R7](#) [ICS-](#)  
[41350](#) [ICS-43432](#) [ICS-40181](#) [ICS-40300](#) [ICS-40619](#) [ICS-40310](#) [MM042602-4](#) [PMM-3738-VM1010-R](#) [ICS-52000](#) [SPW0442HR5H-1](#)  
[MM042602-5](#) [INMP504ACEZ-R7](#) [ICS-40720](#) [INMP510ACEZ-R7](#) [MM033802-1](#) [ICS-43434](#) [ICS-40618](#) [INMP521ACEZ-R7](#) [ICS-40180](#)  
[ASDM4-12.000MHZ-LC-T](#) [ASFLM2-28.224MHZ-LR-T](#) [9003AC-14-33EQ25.00000](#) [1618AA-13-33S-16.000000G](#) [SPQ0410HE5H-PB](#)  
[PMM-3738-VM1000-R](#) [ASEMDLP-LY](#)