

MOUNTING

The sensor can be mounted in any place by means of double-sided adhesive tape or wall plugs 5x(3x30) mm.

Mounting by means of wall plugs:

1. Remove the upper cover - to do it put a screwdriver into a slot between the cover and the base and switch it lifting up the cover at the same time.
2. Choose a place on the wall to mount the RCR-01 device, make two holes corresponding mounting holes from the transmitter's base.
3. Set wall plugs in the holes.
4. Fix the base by means of tightening screws into wall plugs.
5. Place the upper cover's latches into the latches of the base.

CAUTION: The device has factory mounted batteries secured with special separator. Before the first device use remove the separator.

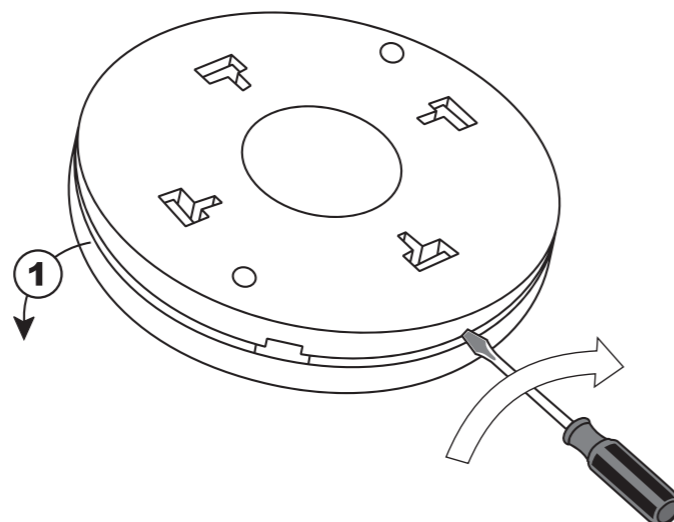

APPLICATION

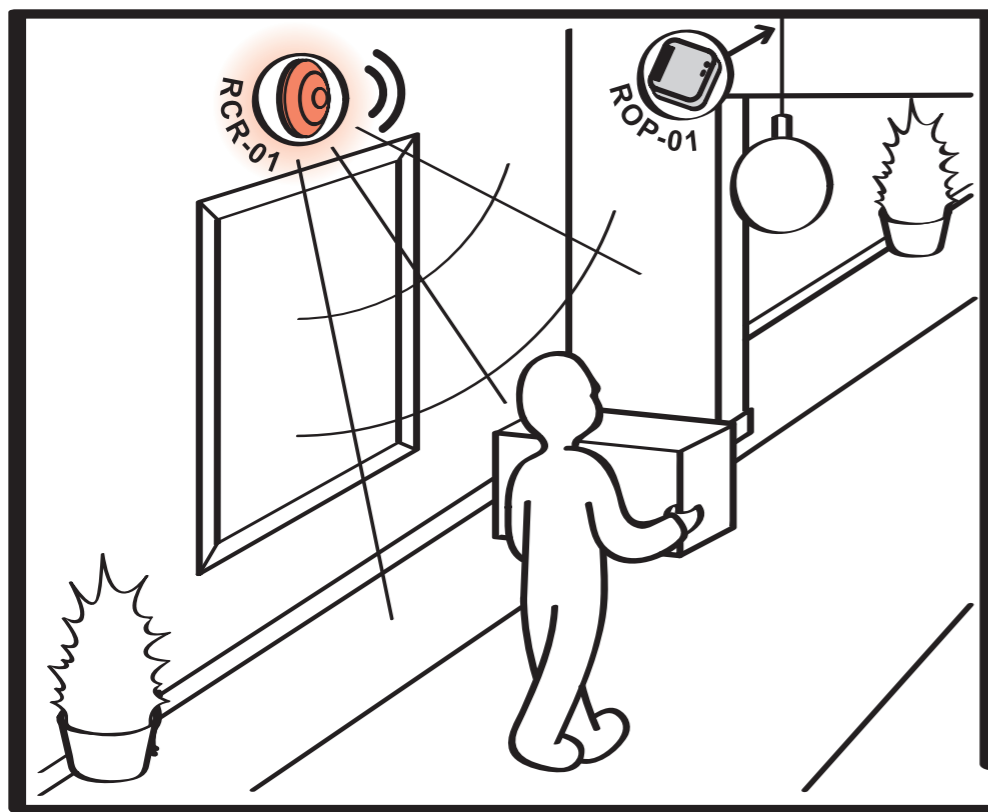

Wireless lighting operation system. RCR-01 sensor sends a radio control signal to ROP-01 receiver after movement detection.



WARRANTY CARD

There is 24 months guarantee on the product

1. ZAMEL provides a two-year warranty for its products.
2. The ZAMEL warranty does not cover: a) mechanical defects resulting from transport, loading / unloading or other circumstances b) defects resulting from incorrect installation or operation of ZAMEL products; c) defects resulting from any changes made by CUSTOMERS or third parties, to products sold or equipment necessary for the correct operation of products sold; d) defects resulting from force majeure or other aleatory events for which ZAMEL is not liable; e) power supply (batteries) to be equipped with a device in the moment of sale (if they appear);
3. All complaints in relation to the warranty must be provided by the CUSTOMER in writing to the retailer after discovering a defect.;
4. ZAMEL will review complaints in accordance with existing regulations.;
5. The way a complaint is settled, e.g. replacement of the product, repair or refund, is left to the discretion of ZAMEL.
6. Guarantee does not exclude, does not limit, nor does it suspend the rights of the PURCHASER resulting from the discrepancy between the goods and the contract.

Salesman stamp and signature, date of sale

RADIO MOTION SENSOR RCR-01

MANUAL INSTRUCTION



ZAMEL Sp. z o.o.

zameL

ul. Zielona 27, 43-200 Pszczyna, Poland
tel. +48 (32) 210 46 65, fax +48 (32) 210 80 04
www.zamelcet.com, e-mail: marketing@zamel.pl

DESCRIPTION

RCR-01 radio motion sensor is an independent battery powered transmitter. The sensor detects heat radiation changes caused by the presence or movement of an object which is in the operation range. After movement detection the system sends a radio signal to a programmed receiver or a group of receivers which control lighting. The motion sensor is resistant to the ambient temperature changes and to air thermal motion. Operation mode with twilight sensor (with adjusted sensitivity of luminous density measurement) enables to limit sensor's operation range to operation after twilight.

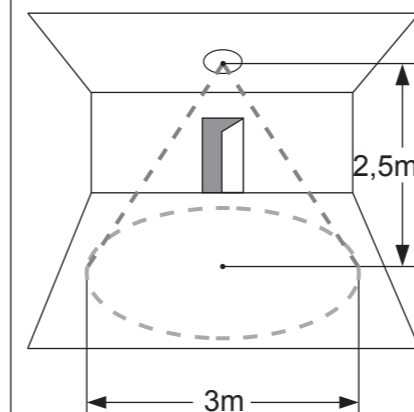

Operation range (ceiling mounting)
Angle of view: 60°
Operation range: 2,5 m

FEATURES

- (PIR) motion sensor used in radio control of EXTA FREE receivers;
- easy installation and mounting by means of double-sided adhesive tape or screws;
- twilight switch is built-in (motion sensor operation can be blocked e.g. during a day);
- sending information and battery status are optically signalled;
- wide range of operation (up to 200m);
- possibility of cooperation with any number of EXTA FREE system receivers;
- possibility of simultaneous switching on/switching off any number of EXTA FREE system receivers;
- possibility of increasing operation range by means of RTN-01 retransmitter.

TECHNICAL DATA

RCR-01	
Input rated voltage:	3 V DC
Battery type:	2x AAA / R03
Battery life:	1 year (depending on use)
Number of channels:	1
Twilight sensor adjustment range:	2 ÷ 20 lx
Transmission:	radio 868,32 MHz
Coding way:	unidirectional
Coding:	addressing transmission
Range:	up to 200 m in the open area
Optic signalling of transmitter's operation:	LED red diode
Ambient temperature range:	-10 ÷ +55 °C
Operating position:	free
Casing mounting:	wall plugs, double-sided adhesive tape
Casing protection degree:	IP20 (EN 60529)
Protection level:	III
Pollution degree:	2
Dimensions:	Ø70 x 40 mm
Weight:	0,07 kg
Reference standard:	ETSI EN 300 220-1, ETSI EN 300 220-2

APPEARANCE

Battery bases

Switches of operation modes

Motion sensor lens

Optic signalling range of operation

PROG push-button

Sensitivity potentiometer



The symbol means selective collecting of electrical and electronic equipment. It is forbidden to put the used equipment together with other waste.

CE 1471

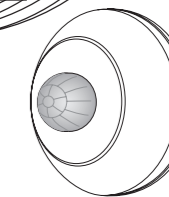

OPERATION

The device can operate in two modes: 1. Motion sensor, 2. Motion sensor with twilight switch. Operation modes are adjusted by means of two switches which are under the top cover of the sensor. Mode 1 - adjust the switch to „C” position, Mode 2 - adjust the switch to „F” position. **It is important to adjust the switches in the same position, otherwise they operate incorrectly.** In the operation mode with a twilight sensor adjust luminous density by means of a potentiometer. Potentiometer adjustment to „☉” sign means operation adjustment during daylight - about 20 lx, and potentiometer adjustment to „☾” sign means operation adjustment during night - about 2 lx. Radio transmission range (up to 200 m - depending on a receiver) can be increased by means of a re-transmitter or few RTN-01 retransmitters.

PROGRAMMING OF RECEIVERS

Mode 1. Motion sensor (operation modes' switches in C-C position)

In this mode the receiver should be programmed to operate in time mode; time should be adjusted to 15 seconds. When there is a movement within detection area the device sends a signal to the receiver every 10 seconds. After a signal has been sent, adjusted time t is counted again.

CAUTION: After each pressing of a push-button in a sensor, there are 10 seconds to start the next programming step. After 10 seconds LED diode switches off in the sensor and RCR-01 device starts usual operation (programming procedure must be started again).

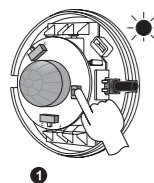

1 Press PROG push-button of RCR-01, next release the push-button. LED red diode switches on under the lens (constant signal).

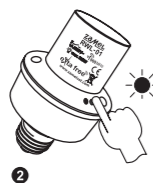

2 Press PROG push-button to adjust the receiver to programming mode. LED red diode in the receiver switches on (constant signal).

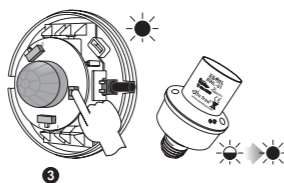

3 Press PROG push-button of RCR-01 device and then release it. LED red diode in the receiver switches on (first signal pulsates, next the signal is constant).

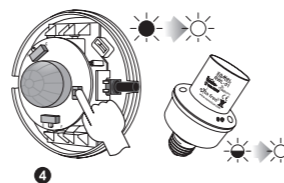

4 Press PROG push-button of RCR-01 device and then release it. LED red diode in the receiver switches on (signal pulsates), and then switches off - THE SENSOR IS ADDED. Wait until LED diode in RCR-01 device switches off.

Mode 2. Motion sensor with twilight switch (operation modes' switches in F-F position).

In this mode the receiver should be programmed to operate in monostable mode. When there is a movement within detection area the sensor sends a switch on signal to the receiver.

The sensor sends a switch off signal after 20 seconds from the moment of no movement in the detection area.

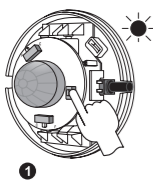

1 Press PROG push-button of RCR-01 device, next release the push-button. LED red diode switches on under the lens (constant signal).

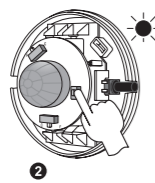

2 Press PROG push-button of RCR-01 device again for a longer time.



3 Press PROG push-button to adjust the receiver to the programming mode. LED red diode in the receiver switches on (constant signal).

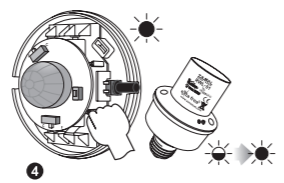

4 Release PROG push-button of RCR-01 device. LED red diode in the receiver switches on (first signal pulsates, next the signal is constant).

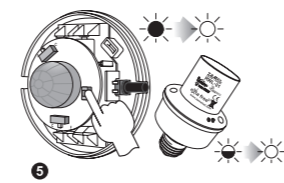

5 Press PROG push-button of RCR-01 device and then release it. LED red diode in the receiver switches on (signal pulsates), and then switches off - THE SENSOR IS ADDED. Wait until LED diode in RCR-01 device switches off.

An exemplary programming procedure with the use of RWL-01 receiver. The procedure for the rest of radio EXTA FREE transmitters is analogous.

BATTERY CHANGE

Battery discharge status is signalled by several LED red diode flashes during transmission time.

1. Remove the upper cover of the transmitter.
2. Remove the upper printed-circuit board.
3. Remove the batteries.

4. Mount new batteries. **Watch battery polarisation marked on the latch. Wrong battery mounting may cause device damage.**

5. Mount the upper printed-circuit board inserting the pins into the connectors.

6. Mount the upper cover's latches into the latches of the base.

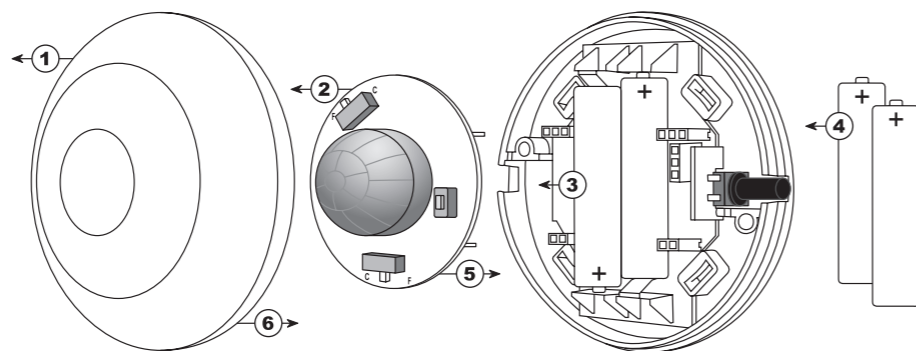

COOPERATION AND OPERATING RANGE

Symbol	ROP-01	ROP-02	ROB-01	SRP-02	SRP-03	RWG-01	RWL-01	ROM-01	ROM-10	RDP-01	RTN-01
RNK-02	180 m	200 m	200 m	200 m	200 m	250 m	180 m	250 m	250 m	180 m	250 m
RNK-04	180 m	200 m	200 m	200 m	200 m	250 m	180 m	250 m	250 m	180 m	250 m
P-256/8	230 m	250 m	250 m	250 m	250 m	300 m	200 m	300 m	300 m	230 m	300 m
P-257/4 (2)	180 m	200 m	200 m	200 m	200 m	250 m	180 m	250 m	250 m	180 m	250 m
RNM-10	230 m	250 m	250 m	250 m	250 m	300 m	200 m	300 m	300 m	230 m	300 m
RNP-01	160 m	180 m	180 m	180 m	180 m	200 m	160 m	200 m	200 m	160 m	200 m
RNP-02	160 m	180 m	180 m	180 m	180 m	200 m	160 m	200 m	200 m	160 m	200 m
RNL-01	160 m	180 m	180 m	lack*	lack*	200 m	160 m	200 m	200 m	160 m	200 m
RTN-01	200 m	200 m	200 m	200 m	200 m	250 m	200 m	250 m	250 m	200 m	250 m
RCR-01	160 m	180 m	180 m	lack*	lack*	200 m	160 m	200 m	200 m	160 m	200 m
RTI-01	160 m	180 m	180 m	180 m	180 m	200 m	160 m	200 m	200 m	160 m	200 m
RXM-01	230 m	250 m	250 m	250 m	250 m	300 m	200 m	300 m	300 m	230 m	300 m

* - 1-channel transmitters do not cooperate with roller blind controllers.

CAUTION: The given range concerns open area - an ideal condition without any natural or artificial obstacles. If there are some obstacles between a transmitter and a receiver, it is advisable to decrease the range according to: wood and plaster: from 5 to 20 %, bricks: from 10 to 40 %, reinforced concrete: from 40 to 80 %, metal: from 90 to 100%, glass: from 10 to 20 %. Over- and underground medium and high electrical power lines, radio and television transmitters, GSM transmitters set close to a device system have also a negative influence on the range.

WHEN THE RADIO SIGNALS GO THROUGH OBSTACLES THERE IS OPERATION RANGE DECREASE



bricks 10% to 40 %, wood and plaster 5% to 20 %, reinforced concrete 40% to 80 %, metal 90% to 100%, glass 10% to 20%

TRANSMITTERS		RECEIVERS	
RNK-02 2-channel button radio transmitter		RNL-01 Radio foot transmitter	
RNK-04 4-channel button radio transmitter		ROP-01 1-channel radio receiver	
P-256/8 8-channel remote controller		ROP-02 2-channel radio receiver	
P-257/4 4-channel remote controller		RDP-01 1-channel radio dimmer	
P-257/2 2-channel remote controller		ROB-01/12-24V Radio gate controller	
RCR-01 Radio motion sensor		ROM-01 1-channel radio modular receiver	
		ROM-10 2-channel radio modular receiver	
		ACCESSORIES	
		ANT-01 External antenna	
		RTN-01 Retransmitter	

X-ON Electronics

Largest Supplier of Electrical and Electronic Components

Click to view similar products for [Power Management IC Development Tools](#) category:

Click to view products by [Zamel](#) manufacturer:

Other Similar products are found below :

[EVAL6482H-DISC](#) [EVAL-AD5522EBUZ](#) [EVAL-ADM1060EBZ](#) [EVAL-ADM1073MEBZ](#) [EVAL-ADM1166TQEBZ](#) [EVAL-ADM1168LQEBZ](#) [EVAL-ADM1171EBZ](#) [EVAL-ADM1276EBZ](#) [EVB-EN5319QI](#) [EVB-EN5365QI](#) [EVB-EN6347QI](#) [EVB-EP5348UI](#) [MIC23158YML EV](#) [MIC23451-AAAYFL EV](#) [MIC5281YMME EV](#) [124352-HMC860LP3E](#) [ADM00513](#) [ADM8611-EVALZ](#) [ADM8612-EVALZ](#) [ADM8613-EVALZ](#) [ADM8615-EVALZ](#) [ADP1046ADC1-EVALZ](#) [ADP1055-EVALZ](#) [ADP122-3.3-EVALZ](#) [ADP130-0.8-EVALZ](#) [ADP130-1.2-EVALZ](#) [ADP130-1.5-EVALZ](#) [ADP130-1.8-EVALZ](#) [ADP160UJZ-REDYKIT](#) [ADP166UJ-EVALZ](#) [ADP1712-3.3-EVALZ](#) [ADP1714-3.3-EVALZ](#) [ADP1715-3.3-EVALZ](#) [ADP1716-2.5-EVALZ](#) [ADP1740-1.5-EVALZ](#) [ADP1752-1.5-EVALZ](#) [ADP1754-1.5-EVALZ](#) [ADP1828LC-EVALZ](#) [ADP1870-0.3-EVALZ](#) [ADP1871-0.6-EVALZ](#) [ADP1873-0.6-EVALZ](#) [ADP1874-0.3-EVALZ](#) [ADP1876-EVALZ](#) [ADP1879-1.0-EVALZ](#) [ADP1882-1.0-EVALZ](#) [ADP1883-0.6-EVALZ](#) [ADP197CB-EVALZ](#) [ADP199CB-EVALZ](#) [ADP2102-1.25-EVALZ](#) [ADP2102-1.2-EVALZ](#)