

1A Synchronous Buck-Boost High Current LED Driver

FEATURES

- **High Efficiency: >90% Typical in Torch Mode, >80% in Flash Mode**
- **Wide V_{IN} Range: 2.7V to 5.5V**
- **Up to 1A Continuous Output Current**
- **3.5% LED Current Programming Accuracy**
- Internal Soft-Start
- Open/Shorted LED Protection
- Constant Frequency 1MHz Operation
- Zero Shutdown Current
- Overtemperature Protection
- Small Thermally Enhanced 10-Lead (3mm × 3mm) DFN Package

APPLICATIONS

- Cell Phone Camera Flash
- Cell Phone Torch Lighting
- Digital Cameras
- PDAs
- Misc Li-Ion LED Drivers

DESCRIPTION

The LTC[®]3454 is a synchronous buck-boost DC/DC converter optimized for driving a single high power LED at currents up to 1A from a single cell Li-Ion battery input. The regulator operates in either synchronous buck, synchronous boost, or buck-boost mode depending on input voltage and LED forward voltage. P_{LED}/P_{IN} efficiency greater than 90% can be achieved over the entire usable range of a Li-Ion battery (2.7V to 4.2V).

LED current is programmable to one of four levels, including shutdown, with dual external resistors and dual enable inputs. In shutdown no supply current is drawn.

A high constant operating frequency of 1MHz allows the use of small external components. The LTC3454 is offered in a low profile (0.75mm) thermally enhanced 10-lead (3mm × 3mm) DFN package.

LT, LT, LTC and LTM are registered trademarks of Linear Technology Corporation. All other trademarks are the property of their respective owners.

TYPICAL APPLICATION

High Efficiency Torch/Flash LED Driver

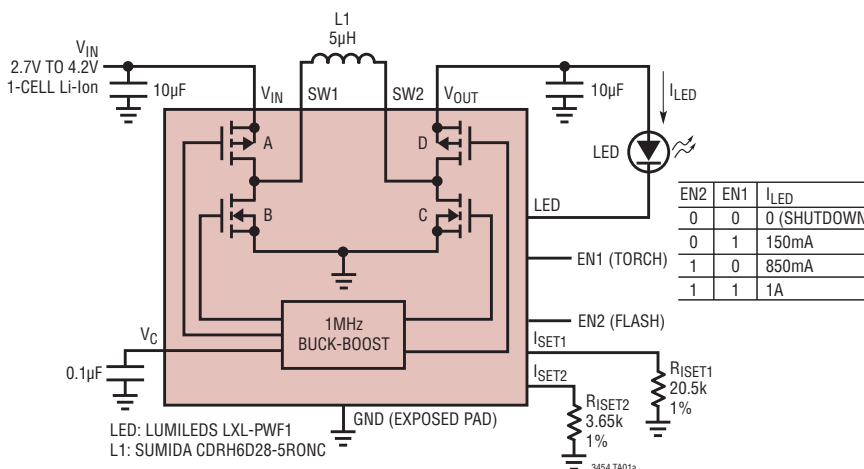

LED Power Efficiency vs V_{IN}

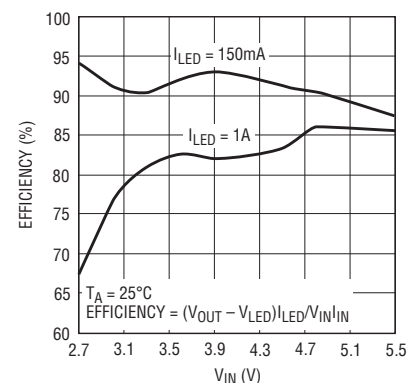

3454 TA01b

ABSOLUTE MAXIMUM RATINGS

(Note 1)

V_{IN} , SW1, SW2, V_{OUT} Voltage.....	-0.3V to 6V
V_C , EN1, EN2, I_{SET1} , I_{SET2} Voltage.....	-0.3V to ($V_{IN} + 0.3V$) or 6V
LED Peak Current.....	1.25A
Storage Temperature Range.....	-65°C to 125°C
Operating Temperature Range (Note 2)....	-40°C to 85°C
Junction Temperature (Note 3)	125°C

PIN CONFIGURATION

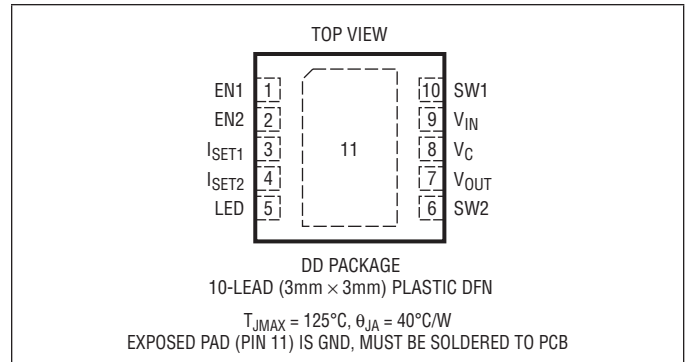

ORDER INFORMATION

LEAD FREE FINISH	TAPE AND REEL	PART MARKING	PACKAGE DESCRIPTION	TEMPERATURE RANGE
LTC3454EDD#PBF	LTC3454EDD#TRPBF	LBQX	10-Lead (3mm x 3mm) Plastic DFN	-40°C to 85°C

Consult LTC Marketing for parts specified with wider operating temperature ranges.

Consult LTC Marketing for information on non-standard lead based finish parts.

For more information on lead free part marking, go to: <http://www.linear.com/leadfree/>

For more information on tape and reel specifications, go to: <http://www.linear.com/tapeandreeel/>

ELECTRICAL CHARACTERISTICS

The ● denotes the specifications which apply over the full operating temperature range, otherwise specifications are at $T_A = 25^\circ\text{C}$. $V_{IN} = 3.6\text{V}$, $R_{ISET} = 20.5\text{k}$ unless otherwise noted. (Note 2)

PARAMETER	CONDITIONS	MIN	TYP	MAX	UNITS	
Input Supply Voltage (V_{IN})		● 2.7		5.5	V	
Input DC Supply Current	(Typicals at $V_{IN} = 3.6\text{V}$, $R_{ISET1} = R_{ISET2} = 20.5\text{k}$)	●				
Normal Operation	$2.7\text{V} \leq V_{IN} \leq 5.5\text{V}$ (Note 4)		825	1200	μA	
Shutdown	$2.7\text{V} \leq V_{IN} \leq 5.5\text{V}$, $V_{EN1} = V_{EN2} = 0\text{V}$		0	1	μA	
UVLO	$V_{IN} < \text{UVLO Threshold}$, $V_{EN1} = V_{EN2} = V_{IN}$		5	10	μA	
Undervoltage Lockout Threshold	V_{IN} Rising	●	2.05	2.3	V	
	V_{IN} Falling	1.75	1.90		V	
V_{EN1} , V_{EN2} DC Threshold for Normal Operation (V_{IH})		●	0.68	1.2	V	
V_{EN1} , V_{EN2} DC Threshold for Shutdown (V_{IL})		●	0.2	0.66	V	
V_{EN1} , V_{EN2} Input Current		●	-1	1	μA	
I_{SET1} and I_{SET2} Servo Voltage	$3.08\text{k} \leq R_{ISET1} R_{ISET2} \leq 20.5\text{k}$	●	780 788	800 800	mV mV	
LED Output Current to Programming Current Ratio	$I_{LED} / (I_{SET1} + I_{SET2})$, $I_{LED} = 500\text{mA}$ (Note 5)	●	3725 3775	3850 3850	mA/mA mA/mA	
LED Pin Voltage	$I_{LED} = 1\text{A}$		105		mV	
Regulated Maximum V_{OUT}	LED Pin Open, Programmed $I_{LED} = 1\text{A}$	●	4.95	5.15	5.35	V
PMOS Switch R_{ON}	Switches A and D ($V_{OUT} = 3.6\text{V}$)		170		$\text{m}\Omega$	
NMOS Switch R_{ON}	Switches B and C		130		$\text{m}\Omega$	
Forward Current Limit	Switch A		2.5	3.4	A	
Reverse Current Limit	Switch D ($V_{OUT} = 3.6\text{V}$)		275		mA	
PMOS Switch Leakage	Switches A, D		-1	1	μA	
NMOS Switch Leakage	Switches B, C		-1	1	μA	

3454fa

ELECTRICAL CHARACTERISTICS

The ● denotes the specifications which apply over the full operating temperature range, otherwise specifications are at $T_A = 25^\circ\text{C}$. $V_{IN} = 3.6\text{V}$, $R_{ISET} = 20.5\text{k}$ unless otherwise noted. (Note 2)

PARAMETER	CONDITIONS	MIN	TYP	MAX	UNITS
Oscillator Frequency		0.9	1.0	1.15	MHz
Soft-Start Time			200		μs

Note 1: Stresses beyond those listed under Absolute Maximum Ratings may cause permanent damage to the device. Exposure to any Absolute Maximum Rating condition for extended periods may affect device reliability and lifetime.

Note 2: The LTC3454 is guaranteed to meet specifications from 0°C to 70°C . Specifications over the -40°C to 85°C operating temperature range are assured by design, characterization and correlation with statistical process controls.

Note 3: T_J is calculated from the ambient temperature T_A and power dissipation PD according to the following formula:

$$T_J = T_A + (PD \cdot \theta_{JA} \text{ } ^\circ\text{C/W}).$$

Note 4: Dynamic supply current is higher due to the gate charge being delivered at the switching frequency.

Note 5: This parameter is tested using a feedback loop which servos V_C to 1.8V.

TYPICAL PERFORMANCE CHARACTERISTICS

Undervoltage Lockout Threshold vs Temperature

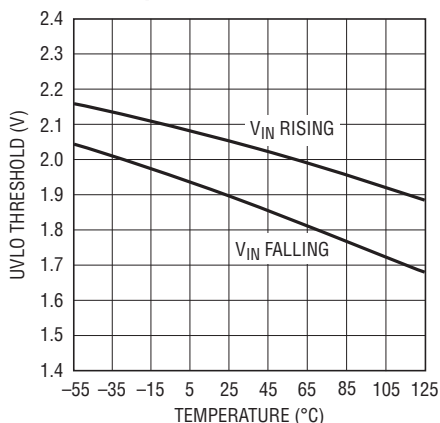

3454 G01

Enable Thresholds vs Temperature

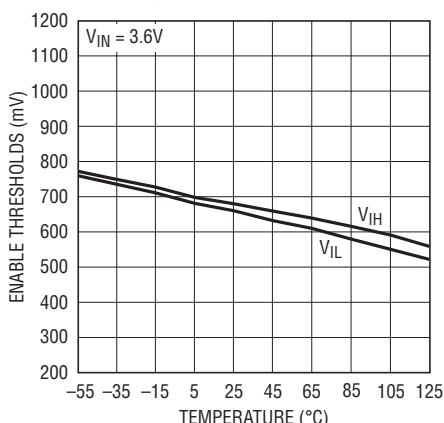

3454 G02

Enable Thresholds vs V_{IN}

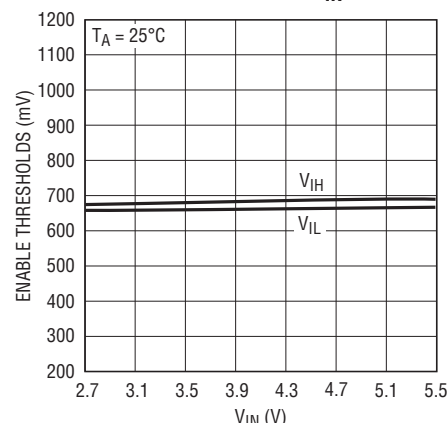

3454 G03

$I_{SET1,2}$ Servo Voltage vs Temperature

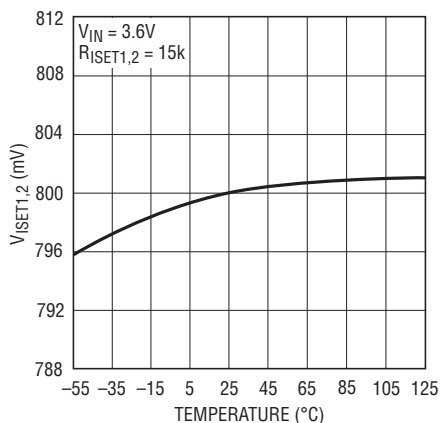

3454 G04

$I_{SET1,2}$ Servo Voltage vs V_{IN}

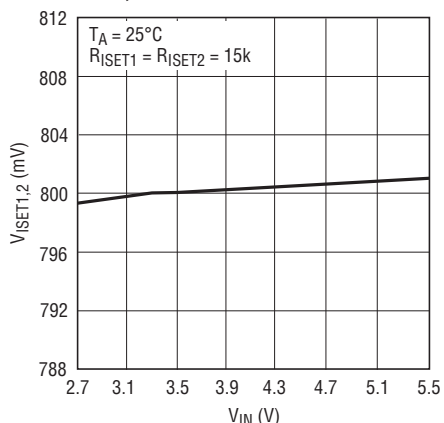

3454 G05

$I_{SET1,2}$ Servo Voltage vs R_{ISET}

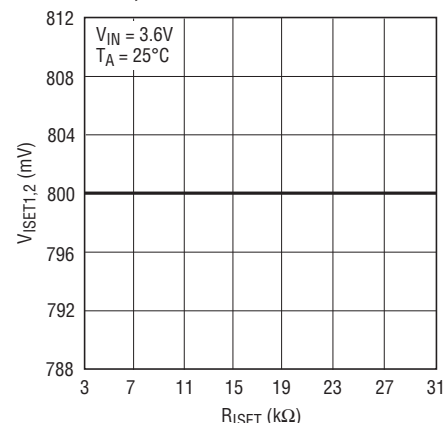

3454 G06

TYPICAL PERFORMANCE CHARACTERISTICS

LED Current Programming Ratio vs Temperature

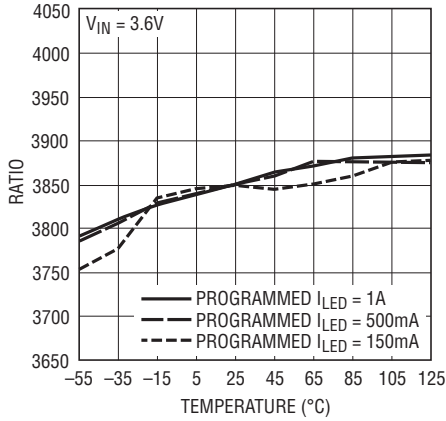

3454 G07

LED Current Programming Ratio vs V_{IN}

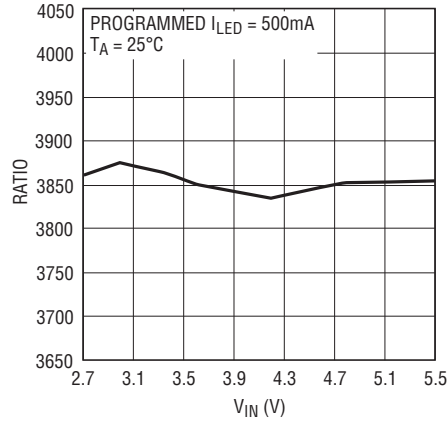

3454 G08

V_{LED} vs Temperature

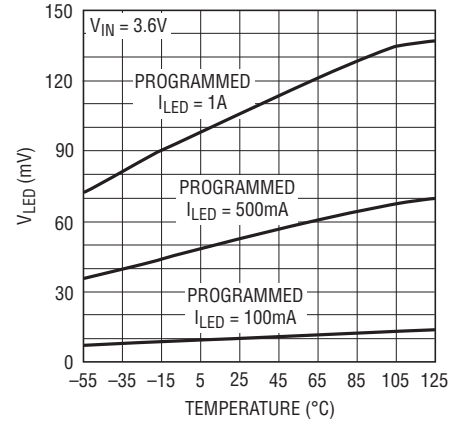

3454 G09

V_{LED} vs V_{IN}

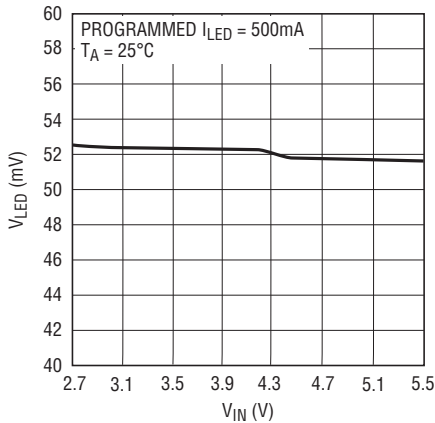

3454 G10

Maximum Regulated V_{OUT} vs Temperature

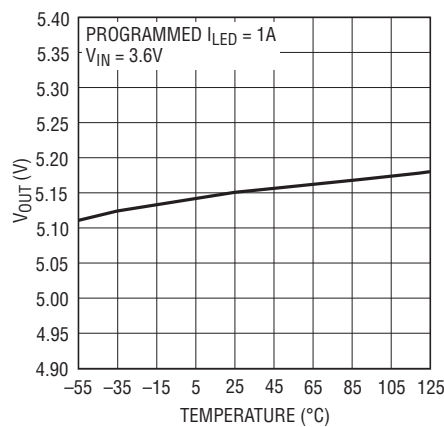

3454 G11

Maximum Regulated V_{OUT} vs V_{IN}

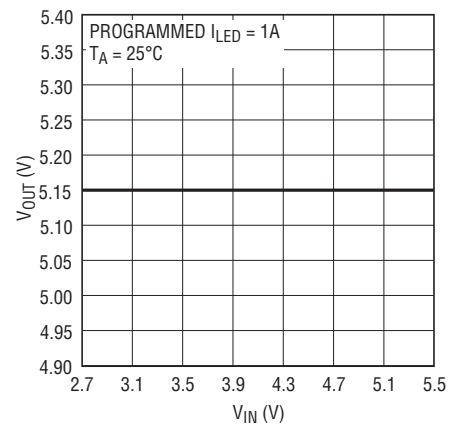

3454 G12

Maximum Regulated V_{OUT} vs Programmed LED Current

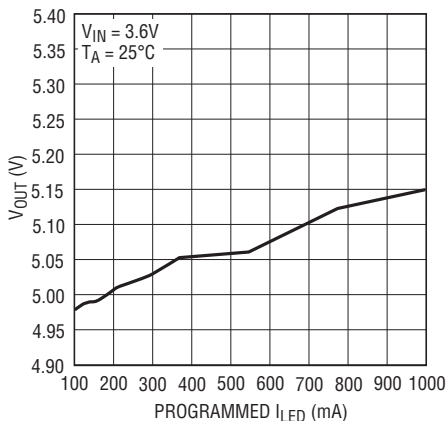

3454 G13

PMOS $R_{DS(ON)}$ vs Temperature

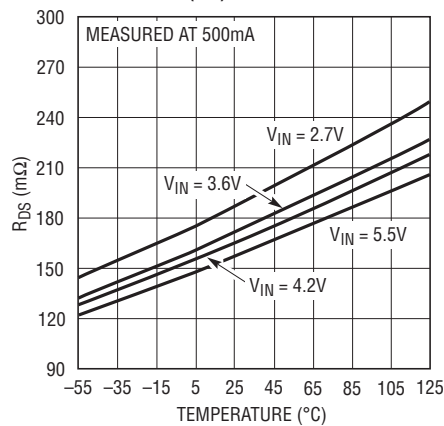

3454 G14

NMOS $R_{DS(ON)}$ vs Temperature

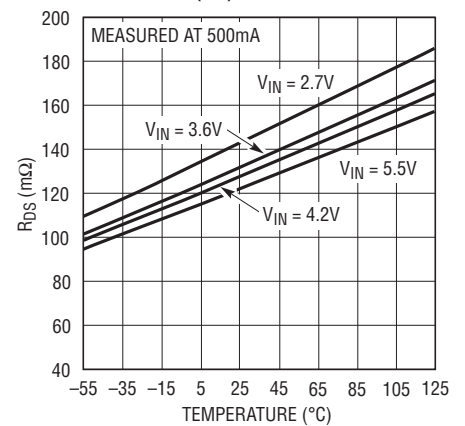

3454 G15

TYPICAL PERFORMANCE CHARACTERISTICS

Oscillator Frequency vs Temperature

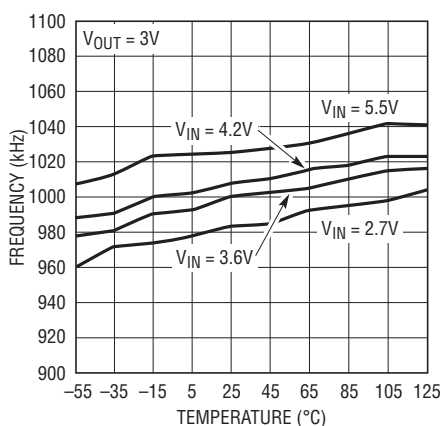

LED Power Efficiency vs LED Current

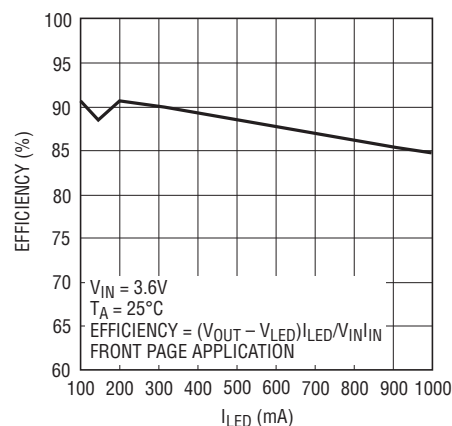

Output Voltage Ripple Back Page Application

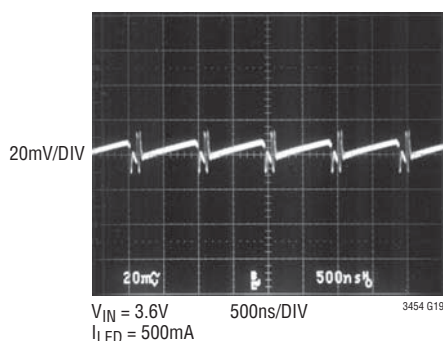

Start-Up Transient Back Page Application

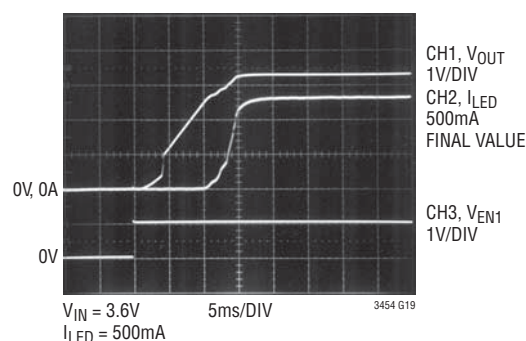

PIN FUNCTIONS

EN1 (Pin 1): Enable Input Pin for I_{SET1} Current.

EN2 (Pin 2): Enable Input Pin for I_{SET2} Current.

I_{SET1} (Pin 3): LED Current Programming Pin. A resistor to ground programs the current through the LED to $I_{LED} = 3850(0.8V/R_{ISET1})$. This amount of current adds to any amount set by EN2/ I_{SET2} if used.

I_{SET2} (Pin 4): LED Current Programming Pin. A resistor to ground programs the current through the LED to $I_{LED} = 3850(0.8V/R_{ISET2})$. This amount of current adds to any amount set by EN1/ I_{SET1} if used.

LED (Pin 5): Low Dropout Output for LED Current Biasing. Connect the LED between V_{OUT} and the LED pin.

SW2 (Pin 6): Switching Node. External inductor connects between SW1 and SW2. Recommended value is $4.7\mu H/5\mu H$.

V_{OUT} (Pin 7): Buck-Boost Output Rail. Bypass to GND with a ceramic capacitor. Recommended value is $10\mu F$.

V_C (Pin 8): Compensation Point for the Internal Error Amplifier Output. Connect a ceramic capacitor from V_C to GND. Recommended value is $0.1\mu F$.

V_{IN} (Pin 9): Voltage Input Supply Pin ($2.7V \leq V_{IN} \leq 5.5V$). Bypass to GND with a ceramic capacitor. Recommended value is $10\mu F$.

SW1 (Pin 10): Switching Node. External inductor connects between SW1 and SW2. Recommended value is $4.7\mu H/5\mu H$.

Exposed Pad (Pin 11): Ground Pin. Solder to PCB ground for electrical contact and optimal thermal performance.

BLOCK DIAGRAM

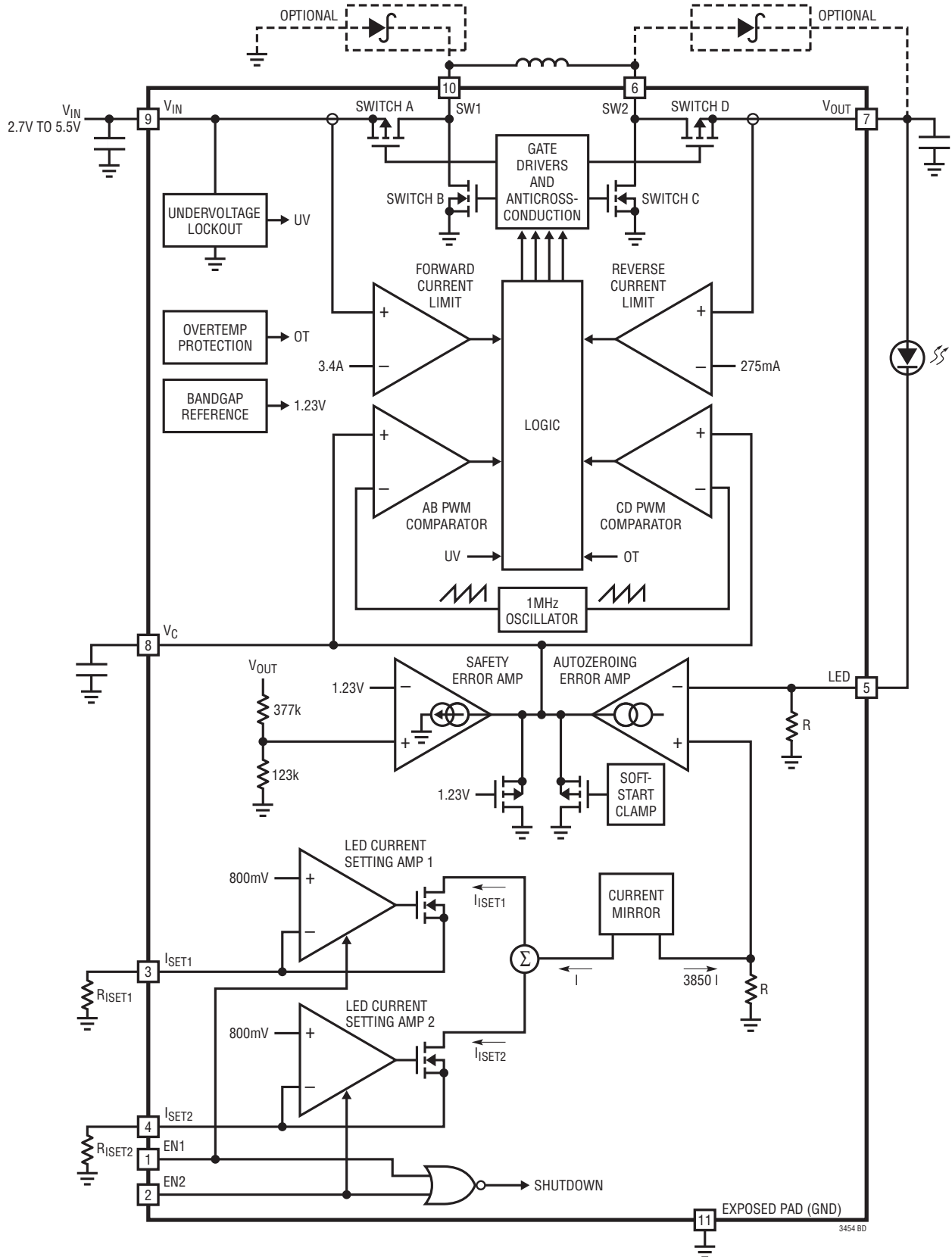

OPERATION

Buck-Boost DC/DC Converter

The LTC3454 employs an LTC proprietary buck-boost DC/DC converter to generate the output voltage required to drive a high current LED. This architecture permits high-efficiency, low noise operation at input voltages above, below or equal to the output voltage by properly phasing four internal power switches. The error amp output voltage on the V_C pin determines the duty cycle of the switches. Since the V_C pin is a filtered signal, it provides rejection of frequencies well below the factory trimmed switching frequency of 1MHz. The low $R_{DS(ON)}$, low gate charge synchronous switches provide high frequency pulse width modulation control at high efficiency. Schottky diodes across synchronous rectifier switch B and synchronous rectifier switch D are not required, but if used do provide a lower voltage drop during the break-before-make time (typically 20ns), which improves peak efficiency by typically 1% to 2% at higher loads.

Figure 1 shows a simplified diagram of how the four internal power switches are connected to the inductor, V_{IN} , V_{OUT} and GND. Figure 2 shows the regions of operation of the buck-boost as a function of the control voltage V_C . The output switches are properly phased so transitions between regions of operation are continuous, filtered and transparent to the user. When V_{IN} approaches V_{OUT} , the buck-boost region is reached where the conduction time of the four switch region is typically 150ns. Referring to Figures 1 and 2, the various regions of operation encountered as V_C increases will now be described.

Buck Mode ($V_{IN} > V_{OUT}$)

In buck mode, switch D is always on and switch C is always off. Referring to Figure 2, when the control voltage V_C is above voltage V1, switch A begins to turn on

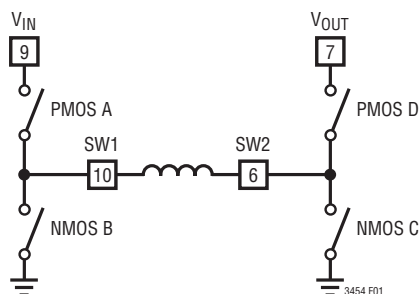

Figure 1. Simplified Diagram of Internal Power Switches

each cycle. During the off time of switch A, synchronous rectifier switch B turns on for the remainder of the cycle. Switches A and B will alternate conducting similar to a typical synchronous buck regulator. As the control voltage increases, the duty cycle of switch A increases until the maximum duty cycle of the converter in buck mode reaches $DC_{BUCK|Max}$ given by:

$$DC_{BUCK|Max} = 100\% - DC_{4SW}$$

where DC_{4SW} equals the duty cycle in % of the “four switch” range.

$$DC_{4SW} = (150ns \cdot f) \cdot 100\%$$

where f is the operating frequency in Hz.

Beyond this point the “four switch” or buck-boost region is reached.

Buck-Boost or 4-Switch Mode ($V_{IN} \approx V_{OUT}$)

Referring to Figure 2, when the control voltage V_C is above voltage V2, switch pair AD continue to operate for duty cycle $DC_{BUCK|max}$, and the switch pair AC begins to phase in. As switch pair AC phases in, switch pair BD phases out accordingly. When the V_C voltage reaches the edge of the buck-boost range at voltage V3, switch pair AC completely phases out switch pair BD and the boost region begins at duty cycle DC_{4SW} . The input voltage V_{IN} where the four switch region begins is given by:

$$V_{IN} = V_{OUT} / [1 - (150ns \cdot f)]$$

and the input voltage V_{IN} where the four switch region ends is given by

$$V_{IN} = V_{OUT} \cdot (1 - DC_{4SW}) = V_{OUT} \cdot [1 - (150ns \cdot f)]$$

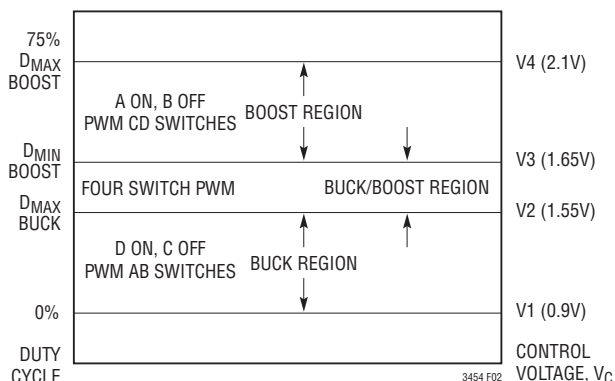

Figure 2. Switch Control vs Control Voltage, V_C

3454fa

APPLICATIONS INFORMATION

Boost Mode ($V_{IN} < V_{OUT}$)

In boost mode, switch A is always on and switch B is always off. Referring to Figure 2, when the control voltage V_C is above voltage V3, switches C and D will alternate conducting similar to a typical synchronous boost regulator. The maximum duty cycle of the converter is limited to 88% typical and is reached when V_C is above V4.

Forward Current Limit

If the current delivered from V_{IN} through PMOS switch A exceeds 3.4A (typical), switch A is shut off immediately. Switches B and D are turned on for the remainder of the cycle in order to safely discharge the forward inductor current at the maximum rate possible.

Reverse Current Limit

If the current delivered from V_{OUT} backwards through PMOS switch D exceeds 275mA (typical), switch D is shut off immediately. Switches A and C are turned on for the remainder of the cycle in order to safely discharge the reverse inductor current at the maximum rate possible.

Undervoltage Lockout

To prevent operation of the power switches at high $R_{DS(ON)}$, an undervoltage lockout is incorporated on the LTC3454. When the input supply voltage drops below approximately 1.90V, the four power switches and all control circuitry are turned off except for the undervoltage block, which draws a few microamperes.

Overtemperature Protection

If the junction temperature of the LTC3454 exceeds 130°C for any reason, all four switches are shut off immediately. The overtemperature protection circuit has a typical hysteresis of 11°C.

Soft-Start

The LTC3454 includes an internally fixed soft-start which is active when powering up or coming out of shutdown. The soft-start works by clamping the voltage on the V_C node and gradually releasing it such that it requires 200 μ s to linearly slew from 0.9V to 2.1V. This has the effect of

limiting the rate of duty cycle change as V_C transitions from the buck region through the buck-boost region into the boost region. Once the soft-start times out, it can only be reset by entering shutdown, or by an undervoltage or overtemperature condition.

Autozero Error Amp

The error amplifier is an autozeroing transconductance amp with source and sink capability. The output of this amplifier drives a capacitor to GND at the V_C pin. This capacitor sets the dominant pole for the regulation loop. (See the Applications Information section for selecting the capacitor value). The feedback signal to the error amp is developed across a resistor through which LED current flows.

Safety Error Amp

The safety error amplifier is a transconductance amplifier with sink only capability. In normal operation, it has no effect on the loop regulation. However, if the LED pin open-circuits, the output voltage will keep rising, and the safety error amp will eventually take over control of the regulation loop to prevent V_{OUT} runaway. The V_{OUT} threshold at which this occurs is approximately 5.15V.

LED Current Programming and Enable Circuit

Two enable pins work in conjunction with dual external resistors to program LED current to one of three nonzero settings. The table below explains how the current can be set.

EN1	EN2	I_{LOAD} (A)
GND	GND	0 (SHUTDOWN)
V_{IN}	GND	$3850 \cdot 0.8V/R_{ISET1}$
GND	V_{IN}	$3850 \cdot 0.8V/R_{ISET2}$
V_{IN}	V_{IN}	$3850 \cdot (0.8V/R_{ISET1} + 0.8V/R_{ISET2})$

With either enable pin pulled high, the buck-boost will regulate the output voltage at the current programmed by R_{ISET1} and/or R_{ISET2} .

With both enable pins pulled to GND, the LTC3454 is in shutdown and draws zero current. The enable pins are high impedance inputs and should not be floated.

APPLICATIONS INFORMATION

COMPONENT SELECTION

Inductor Selection

The high frequency operation of the LTC3454 allows the use of small surface mount inductors. The inductor current ripple is typically set to 20% to 40% of the maximum average inductor current. For a given ripple the inductance term in boost mode is:

$$L > \frac{V_{IN(MIN)}^2 \cdot (V_{OUT} - V_{IN(MIN)}) \cdot 100\%}{f \cdot I_{OUT(MAX)} \cdot \%Ripple \cdot V_{OUT}^2}$$

and in buck mode is:

$$L > \frac{(V_{IN(MAX)} - V_{OUT}) \cdot V_{OUT} \cdot 100\%}{f \cdot V_{IN(MAX)} \cdot \%Ripple \cdot I_{OUT}}$$

where f = operating frequency, Hz

%Ripple = allowable inductor current ripple, %

$V_{IN(MIN)}$ = minimum input voltage, V

$V_{IN(MAX)}$ = maximum input voltage, V

V_{OUT} = output voltage, V

$I_{OUT(MAX)}$ = maximum output load current

For high efficiency, choose an inductor with a high frequency core material, such as ferrite, to reduce core losses. The inductor should have low ESR (equivalent series resistance) to reduce the I^2R losses, and must be able to handle the peak inductor current without saturating. Molded chokes or chip inductors usually do not have enough core to support peak inductor currents >1A. To minimize radiated noise, use a toroid, pot core or shielded bobbin inductor. For white LED application, a 4.7 μ H/5 μ H inductor value is recommended. See Table 1 for a list of component suppliers.

Table 1. Inductor Vendor Information

SUPPLIER	WEB SITE
Coilcraft	www.coilcraft.com
Cooper/Coiltronics	www.cooperet.com
Murata	www.murata.com
Sumida	www.japanlink.com/sumida
Toko	www.toko.com
Vishay-Dale	www.vishay.com

Input Capacitor Selection

Since the V_{IN} pin is the supply voltage for the IC it is recommended to place at least a 2.2 μ F, low ESR bypass capacitor to ground. See Table 2 for a list of component suppliers.

Table 2. Capacitor Vendor Information

SUPPLIER	WEB SITE
AVX	www.avxcorp.com
Sanyo	www.sanyovideo.com
Taiyo Yuden	www.t-yuden.com
TDK	www.component.tdk.com

Output Capacitor Selection

The bulk value of the capacitor is set to reduce the ripple due to charge into the capacitor each cycle. The steady-state ripple due to charge is given by:

$$\%Ripple_Boost = \frac{I_{OUT(MAX)} \cdot (V_{OUT} - V_{IN(MIN)}) \cdot 100\%}{C_{OUT} \cdot V_{OUT}^2 \cdot f}$$

$$\%Ripple_Buck = \frac{(V_{IN(MAX)} - V_{OUT}) \cdot 100\%}{8 \cdot V_{IN(MAX)} \cdot f^2 \cdot L \cdot C_{OUT}}$$

where C_{OUT} = output filter capacitor, F

The output capacitance is usually many times larger in order to handle the transient response of the converter. For a rule of thumb, the ratio of operating frequency to unity-gain bandwidth of the converter is the amount the output capacitance will have to increase from the above calculations in order to maintain desired transient response.

The other component of ripple is due to ESR (equivalent series resistance) of the output capacitor. Low ESR capacitors should be used to minimize output voltage ripple. For surface mount applications, Taiyo Yuden, TDK, AVX ceramic capacitors, AVX TPS series tantalum capacitors or Sanyo POSCAP are recommended. For the white LED application, a 10 μ F capacitor value is recommended. See Table 2 for a list of component suppliers.

Optional Schottky Diodes

Schottky diodes across the synchronous switches B and D are not required, but provide a lower drop during the break-before-make time (typically 20ns) of the NMOS to PMOS transition, improving efficiency. Use a Schottky

TYPICAL APPLICATIONS

diode such as an MBRM120T3 or equivalent. Do not use ordinary rectifier diodes, since the slow recovery times will compromise efficiency.

In applications in which V_{IN} is greater than 4V and V_{OUT} to GND short-circuit protection is needed, a Schottky diode such as MBRM120T3 or equivalent may be used from GND to SW1 and/or a 2Ω/1nF series snubber from SW1 to GND. The Schottky diode should be added as close to the pins as possible. Neither of these is required for shorted LED protection.

In applications in which V_{IN} is greater than 4.5V, a Schottky diode such as MBRM120T3 or equivalent may be required from SW1 to V_{IN} if the LTC3454 is enabled with an output voltage already present. The Schottky diode should be added as close to the pins as possible.

Closing the Feedback Loop

The LTC3454 incorporates voltage mode PWM control. The control to output gain varies with operation region (buck, boost, buck/boost), but is usually no greater than 15. The output filter exhibits a double pole response given by:

$$f_{\text{FILTER_POLE}} = \frac{1}{2 \cdot \pi \cdot \sqrt{L \cdot C_{\text{OUT}}}} \text{ Hz}$$

where C_{OUT} is the output filter capacitor.

The output filter zero is given by:

$$f_{\text{FILTER_ZERO}} = \frac{1}{2 \cdot \pi \cdot R_{\text{ESR}} \cdot C_{\text{OUT}}} \text{ Hz}$$

where R_{ESR} is the capacitor equivalent series resistance.

A troublesome feature in boost mode is the right-half plane zero (RHP), and is given by:

$$f_{\text{RHPZ}} = \frac{V_{\text{IN}}^2}{2 \cdot \pi \cdot I_{\text{OUT}} \cdot L \cdot V_{\text{OUT}}} \text{ Hz}$$

The loop gain is typically rolled off before the RHP zero frequency.

A simple Type I compensation network can be incorporated to stabilize the loop but at a cost of reduced bandwidth

and slower transient response. To ensure proper phase margin, the loop is required to be crossed over a decade before the LC double pole.

The unity-gain frequency of the error amplifier with the Type I compensation is given by:

$$f_{\text{UG}} = \frac{g_m}{2 \cdot \pi \cdot C_{\text{VC}}}$$

where g_m is the error amp transconductance (typically 1/5.2k) and C_{VC} is the external capacitor to GND at the V_C pin. For the white LED application, a 0.1μF or greater capacitor value is recommended.

Maximum LED Current

As described in the Operation section, the output LED current with both enable pins logic high is equal to

$$I_{\text{LED}} = 3850 [0.8V / (R_{\text{ISET1}} \parallel R_{\text{ISET2}})]$$

Since the maximum continuous output current is limited to 1A, this sets a minimum limit on the parallel combination of R_{ISET1} and R_{ISET2} equal to

$$R_{\text{MIN}} = (R_{\text{ISET1}} \parallel R_{\text{ISET2}})_{\text{MIN}} = 3850(0.8V/1A) = 3080\Omega$$

Although the LTC3454 can safely provide this current continuously, the external LED may not be rated for this high a level of continuous current. Higher current levels are generally reserved for pulsed applications, such as LED camera flash. This is accomplished by programming a high current with one of the R_{ISET} resistors and pulsing the appropriate enable pin.

Varying LED Brightness

Continuously variable LED brightness control can be achieved by interfacing directly to one or both of the I_{SET} pins. Figure 3 shows four such methods employing a voltage DAC, a current DAC, a simple potentiometer or a PWM input. It is not recommended to control brightness by PWMing the enable pins directly as this will toggle the LTC3454 in and out of shutdown and result in erratic operation.

APPLICATIONS INFORMATION

LED Failure Modes

If the LED fails as an open circuit, the safety amplifier takes control of the regulation loop to prevent V_{OUT} runaway. The V_{OUT} threshold at which this occurs is about 5.15V. The safety amplifier has no effect on loop regulation at V_{OUT} less than 5.15V.

If the LED fails as a short-circuit, the current limiting circuitry detects this condition and limits the peak input current to a safe level.

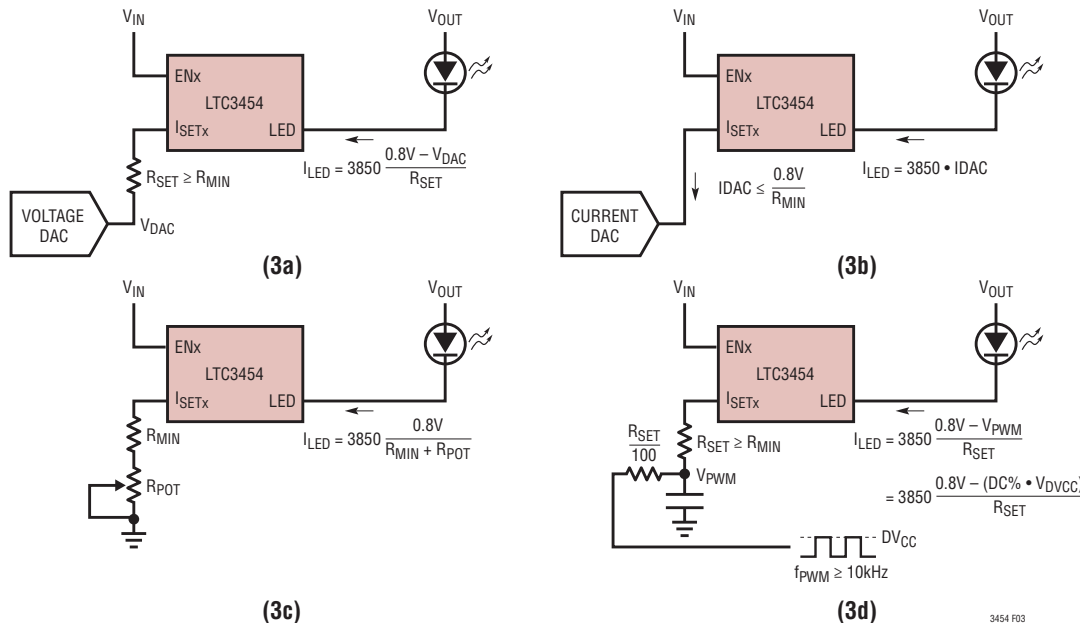
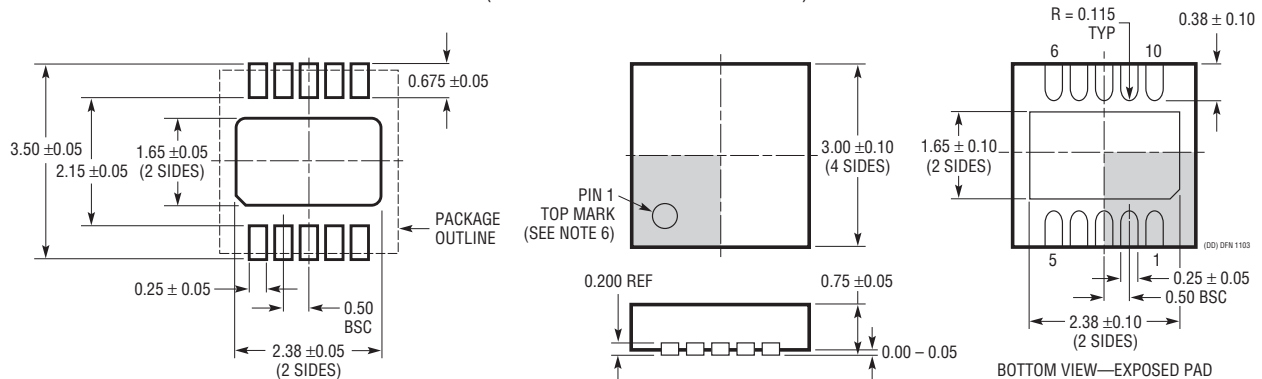

Figure 3. Brightness Control Methods: (a) Using Voltage DAC, (b) Using Current DAC, (c) Using Potentiometer, (d) Using PWM Input

PACKAGE DESCRIPTION

DD Package 10-Lead Plastic DFN (3mm × 3mm) (Reference LTC DWG # 05-08-1699)



RECOMMENDED SOLDER PAD PITCH AND DIMENSIONS

NOTE:

- DRAWING TO BE MADE A JEDEC PACKAGE OUTLINE M0-229 VARIATION OF (WEED-2). CHECK THE LTC WEBSITE DATA SHEET FOR CURRENT STATUS OF VARIATION ASSIGNMENT
- DRAWING NOT TO SCALE
- ALL DIMENSIONS ARE IN MILLIMETERS
- DIMENSIONS OF EXPOSED PAD ON BOTTOM OF PACKAGE DO NOT INCLUDE MOLD FLASH. MOLD FLASH, IF PRESENT, SHALL NOT EXCEED 0.15mm ON ANY SIDE
- EXPOSED PAD SHALL BE SOLDER PLATED
- SHADED AREA IS ONLY A REFERENCE FOR PIN 1 LOCATION ON THE TOP AND BOTTOM OF PACKAGE

TYPICAL APPLICATION

500mA LED Flashlight Driver

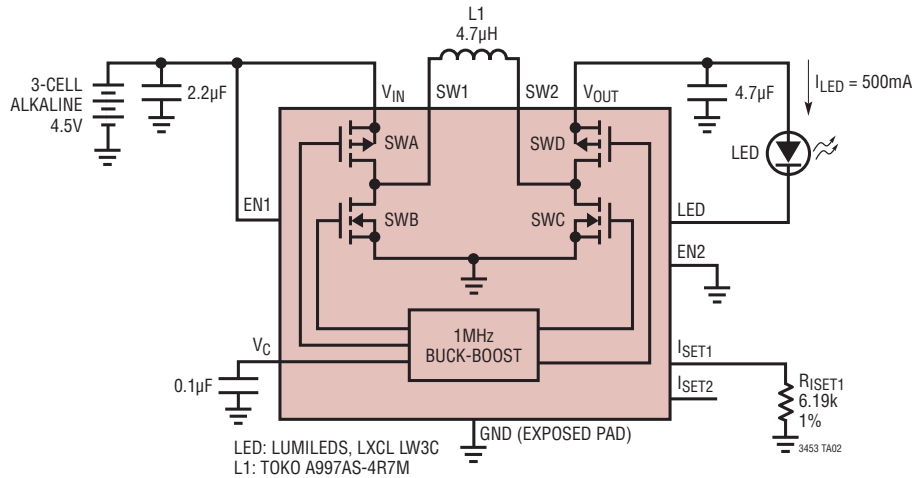

LED Power Efficiency vs V_{IN}

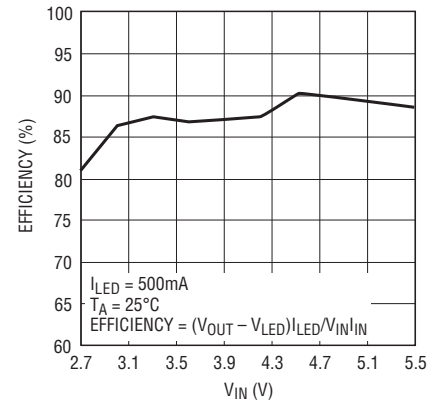

3454 TA02b

RELATED PARTS

PART NUMBER	DESCRIPTION	COMMENTS
LT1618	Constant Current, Constant Voltage 1.4MHz, High Efficiency Boost Regulator	V_{IN} : 1.6V to 18V, $V_{OUT(MAX)}$ = 34V, I_Q = 1.8mA, I_{SD} < 1µA, MS10 Package/EDD Package
LT1930/LT1930A	1A (I_{SW}), 1.2MHz/2.2MHz, High Efficiency Step-Up DC/DC Converter	V_{IN} : 2.6V to 16V, $V_{OUT(MAX)}$ = 34V, I_Q = 4.2mA/5.5mA, I_{SD} < 1µA, ThinSOT Package
LT1932	Constant Current, 1.2MHz, High Efficiency White LED Boost Regulator	V_{IN} : 1V to 10V, $V_{OUT(MAX)}$ = 34V, I_Q = 1.2mA, I_{SD} < 1µA, ThinSOT Package
LT1937	Constant Current, 1.2MHz, High Efficiency White LED Boost Regulator	V_{IN} : 2.5V to 10V, $V_{OUT(MAX)}$ = 34V, I_Q = 1.9mA, I_{SD} < 1µA, ThinSOT Package/SC70 Package
LTC3205	High Efficiency, Multi-Display LED Controller	V_{IN} : 2.8V to 4.5V, $V_{OUT(MAX)}$ = 6V, I_Q = 50µA, I_{SD} < 1µA, QFN-24 Package
LTC3215	700mA Low Noise Charge Pump LED Driver	V_{IN} : 2.9V to 4.4V, $V_{OUT(MAX)}$ = 5.5V, I_Q = 300µA, I_{SD} < 2.5µA, DFN Package
LTC3216	1A Low Noise High Current Charge Pump LED Driver with Independent Flash/Torch Current	V_{IN} : 2.9V to 4.4V, $V_{OUT(MAX)}$ = 5.5V, I_Q = 300µA, I_{SD} < 2.5µA, DFN Package
LTC3440/ LTC3441	600mA/1.2A I_{OUT} , 2MHz/1MHz, Synchronous Buck-Boost DC/DC Converter	V_{IN} : 2.4V to 5.5V, $V_{OUT(MAX)}$ = 5.25V, I_Q = 25µA/50µA, I_{SD} < 1µA, MS-10 Package/DFN Package
LTC3443	600mA/1.2A I_{OUT} , 600kHz, Synchronous Buck-Boost DC/DC Converter	V_{IN} : 2.4V to 5.5V, $V_{OUT(MAX)}$ = 5.25V, I_Q = 28µA, I_{SD} < 1µA, DFN Package
LTC3490	Single Cell 350mA LED Driver	V_{IN} : 1V to 3.2V, $V_{OUT(MAX)}$ = 4V, I_Q = 20µA, I_{SD} = 20µA, DFN Package
LTC3453	Synchronous Buck-Boost High Power White LED Driver	V_{IN} : 2.7V to 5.5V, Up to 500mA Continuous Output Current, QFN-16 Package
LT3465/LT3465A	Constant Current, 1.2MHz/2.7MHz, High Efficiency White LED Boost Regulator with Integrated Schottky Diode	V_{IN} : 2.7V to 16V, $V_{OUT(MAX)}$ = 34V, I_Q = 1.9mA, I_{SD} < 1µA, ThinSOT Package
LT3466	Dual Constant Current, 2MHz, High Efficiency White LED Boost Regulator with Integrated Schottky Diode	V_{IN} : 2.7V to 24V, $V_{OUT(MAX)}$ = 40V, I_Q = 5mA, I_{SD} < 16µA, DFN Package
LT3479	3A, Full Featured DC/DC Converter with Soft-Start and Inrush Current Protection	V_{IN} : 2.5V to 24V, $V_{OUT(MAX)}$ = 40V, I_Q = 6.5mA, I_{SD} < 1µA, DFN Package/TSOPP Package

3454fa

X-ON Electronics

Largest Supplier of Electrical and Electronic Components

Click to view similar products for [LED Lighting Drivers](#) category:

Click to view products by [Analog Devices](#) manufacturer:

Other Similar products are found below :

[LV5235V-MPB-H](#) [MB39C602PNF-G-JNEFE1](#) [MIC2871YMK-T5](#) [MP1518DJ-LF-P](#) [MP3202DG-LF-P](#) [MP3304BDD-LF-P](#) [MP3306EG-LF-P](#) [MP3398AGY](#) [MP4033GK](#) [AL1676-10BS7-13](#) [AL1676-20AS7-13](#) [MX877RTR](#) [NCL30085BDR2G](#) [ICL8201](#) [IS31BL3506B-TTLS2-TR](#) [PAM2841GR](#) [A8519KLPTR-T](#) [FAN5702UMP20X](#) [AL3157F-7](#) [AL8807BQMP-13](#) [LV52204MTTBG](#) [TLD1120EL](#) [MP2488DN-LF](#) [MP24893DQ-LF-P](#) [MP24894GJ-P](#) [MP24895GJ-P](#) [MP3308DL-LF-Z](#) [MP3393EF-LF](#) [MP3394SGF](#) [MP3802DQ-LF-P](#) [MP4008GS](#) [MP4031GS](#) [MP4032-1GS](#) [MP4034GS](#) [MP46885DN-LF](#) [SLG7NT4082VTR](#) [PCA9955BTWQ900J](#) [TLD5095EL](#) [LED6001TR](#) [STP4CMPQTR](#) [BD1604MVV-E2](#) [MC10SX1130DG](#) [MAX16832CASAT](#) [MAX16814CATP+](#) [NCL30086BDR2G](#) [NCL30088BDR2G](#) [IS31LT3350-V1SDLS2-EB3CH](#) [MP3202DJ-LF-P](#) [MP24833GN](#) [STCS1PUR](#)