

## Product Specification

---

### SFP+ Bail and Latch Assembly

---

#### PRODUCT FEATURES

- US patent # 7,351,090
- Bail and latch for SFP+ applications
- Various Bail Color options:
  - Black
  - Blue
  - White
  - Orange
  - Beige
  - Red
  - Brown
  - Green
  - Grey

These parts are designed to provide the latching and release mechanism for pluggable SFP+ modules.

Advanced Optical Components, a division of Finisar Corp., offers the bail and the latch as piece parts for external sale to module manufacturers for use within their particular modules. The bail is available in various colors.

This datasheet provides the mechanical dimensions of the bail and the latch, the material information for the bail and the latch as well as interface directions.

#### PRODUCT SELECTION

Part Number	Description
FTA-BL-SFP+/BLK	BAIL, LF, SFP+, SHEET METAL BASED, BLACK
FTA-BL-SFP+/BLU	BAIL, LF, SFP+, SHEET METAL BASED, BLUE
FTA-BL-SFP+/BGE	BAIL, LF, SFP+, SHEET METAL BASED, BEIGE
FTA-BL-SFP+/ORG	BAIL, LF, SFP+, SHEET METAL BASED, ORANGE
FTA-BL-SFP+/WHT	BAIL, LF, SFP+, SHEET METAL BASED, WHITE
FTA-BL-SFP+/RED	BAIL, LF, SFP+, SHEET METAL BASED, RED
FTA-BL-SFP+/BRW	BAIL, LF, SFP+, SHEET METAL BASED, BROWN
FTA-BL-SFP+/GRN	BAIL, LF, SFP+, SHEET METAL BASED, GREEN
FTA-BL-SFP+/GRY	BAIL, LF, SFP+, SHEET METAL BASED, GREY
FTA-BL-SFP+/YLO	BAIL, LF, SFP+, SHEET METAL BASED, YELLOW
FTA-LT-SFP+	LATCH, SFP+

**SFP+ Bail Assembly**



**SFP+ Latch Assembly**



- NOTE: UNLESS OTHERWISE SPECIFIED  
 1. MATERIAL: ZINC ALLOY NO.3 PER ASTM B84-88.  
 2. FINISH:  
 2.1 N PLATE  
 2.2 CU UNDERPLATE REQUIRED OVER BASE MATERIAL.  
 2.3 ALL DIMENSIONS APPLY AFTER PLATING. PLATING THICKNESS INSPECTION POINTS ARE IDENTIFIED WITH A TRIANGLE.  
 3. ALL INTERNAL RADIUS SHALL BE 0.13mm MAX. CORNER RADIUS SHALL BE 0.13mm MAX.  
 4. MAX DRAFT SHALL BE 1°. ALL DRAFT SHALL BE APPLIED SUCH THAT THE LIMITS OF SIZE NOTED ARE HELD AT THE SURFACES INDICATED.  
 5. GATES AND EJECTORS:  
 6.1 EJECTOR MARKS SHALL NOT CAUSE ANY FEATURE TO BE OUT OF ITS SPECIFIED LIMITS OF SIZE OR LOCATION.  
 6.2 STA INTERSECTING LINE FLASH AND GATE VESTIGE TO BE 0.05mm HIGH MAX.  
 7. CRITICAL SURFACE DIMENSIONS OR PARAMETERS.  
 8.1 CRITICAL TO FUNCTION DIMENSIONS ARE IDENTIFIED WITH AN INSPECTION BUBBLE.

UNLESS OTHERWISE SPECIFIED:  
 DIMENSIONS ARE IN MILLIMETERS  
 TOLERANCES ARE:  
 .XX ± .2  
 .XXX ± .10  
 .XXXX ± .050  
 .XXXXX ± .0250  
 ANGLES ± 1 DEG.

**SFP+ Shell Geometr**

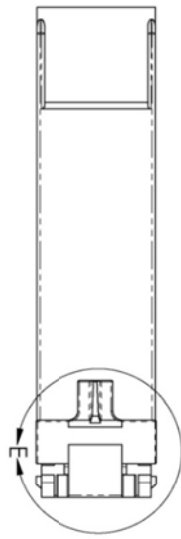
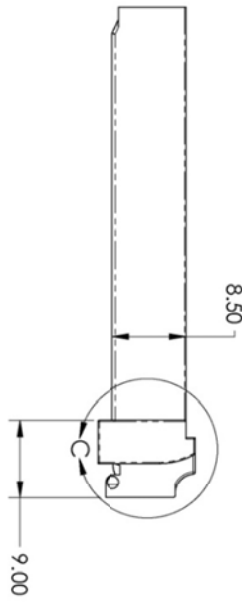
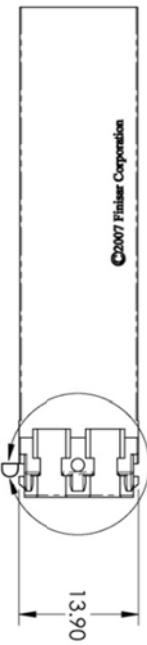
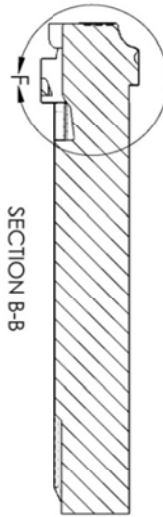

- NOTE: UNLESS OTHERWISE SPECIFIED  
 1. MATERIAL: ZINC ALLOY (NO.3 PER ASTM B86-88).  
 2. FINISH:  
 2.1. Ni PLATE  
 2.2. CU UNDERPLATE REQUIRED OVER BASE MATERIAL.  
 2.3. ALL DIMENSIONS APPLY AFTER PLATING. PLATING THICKNESS INSPECTION POINTS ARE IDENTIFIED WITH A TRIANGLE.  
 3. ALL INTERNAL RADII SHALL BE 0.13mm MAX. CORNER RADII SHALL BE 0.13mm MAX.  
 4. MAX DRAFT SHALL BE 1°. ALL DRAFT SHALL BE APPLIED SUCH THAT THE LIMITS OF SIZE NOTED ARE HELD AT THE SURFACES INDICATED.  
 6. GATES AND EJECTORS:  
 6.1 EJECTOR MARKS SHALL NOT CAUSE ANY FEATURE TO BE OUT OF ITS SPECIFIED LIMITS OF SIZE OR LOCATION.  
 6.2 STANDING PARTING LINE FLASH AND GATE VESTAGE TO BE 0.05mm HIGH MAX.  
 7. CRITICAL INTERFACE DIMENSIONS OR PARAMETERS.  
 8.1 CRITICAL TO FUNCTION DIMENSIONS ARE IDENTIFIED WITH AN INSPECTION BUBBLE.

**SFP+ Bail Shell Geometry**

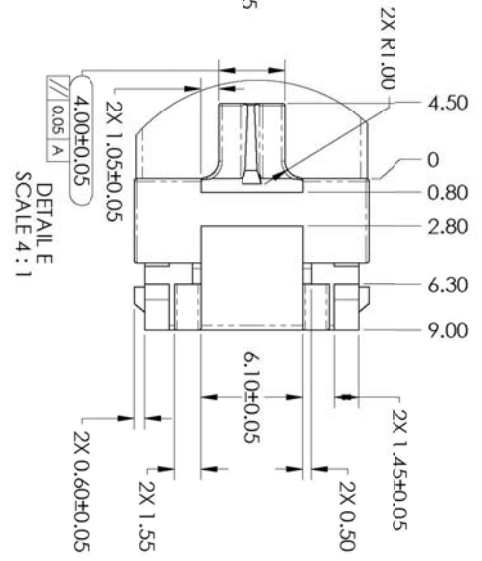
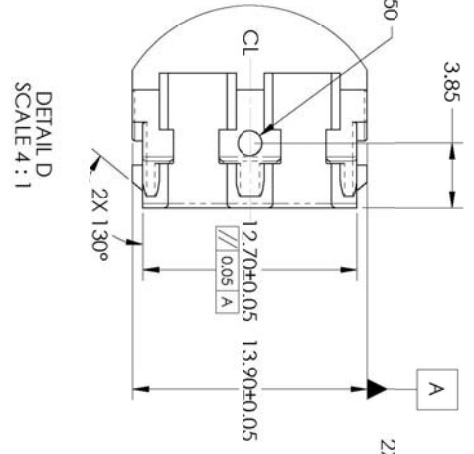
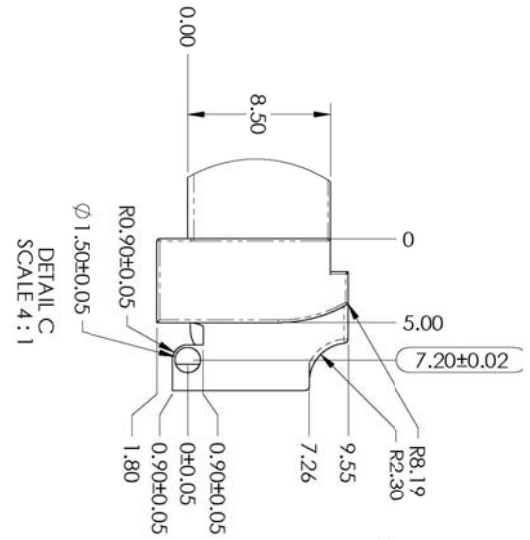
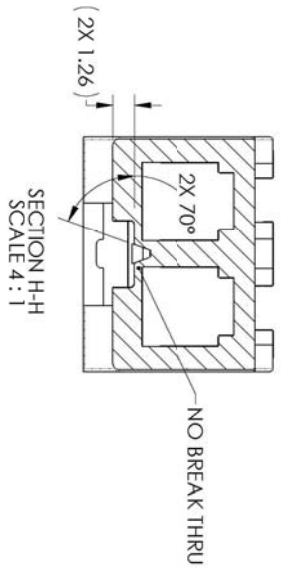
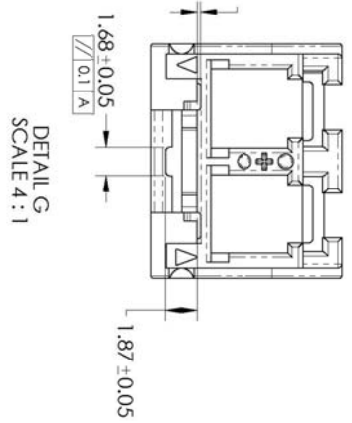

**SFP+ BAIL – SHEET METAL**



**SFP+ BAIL – PAINT TRANSFER DECAL**

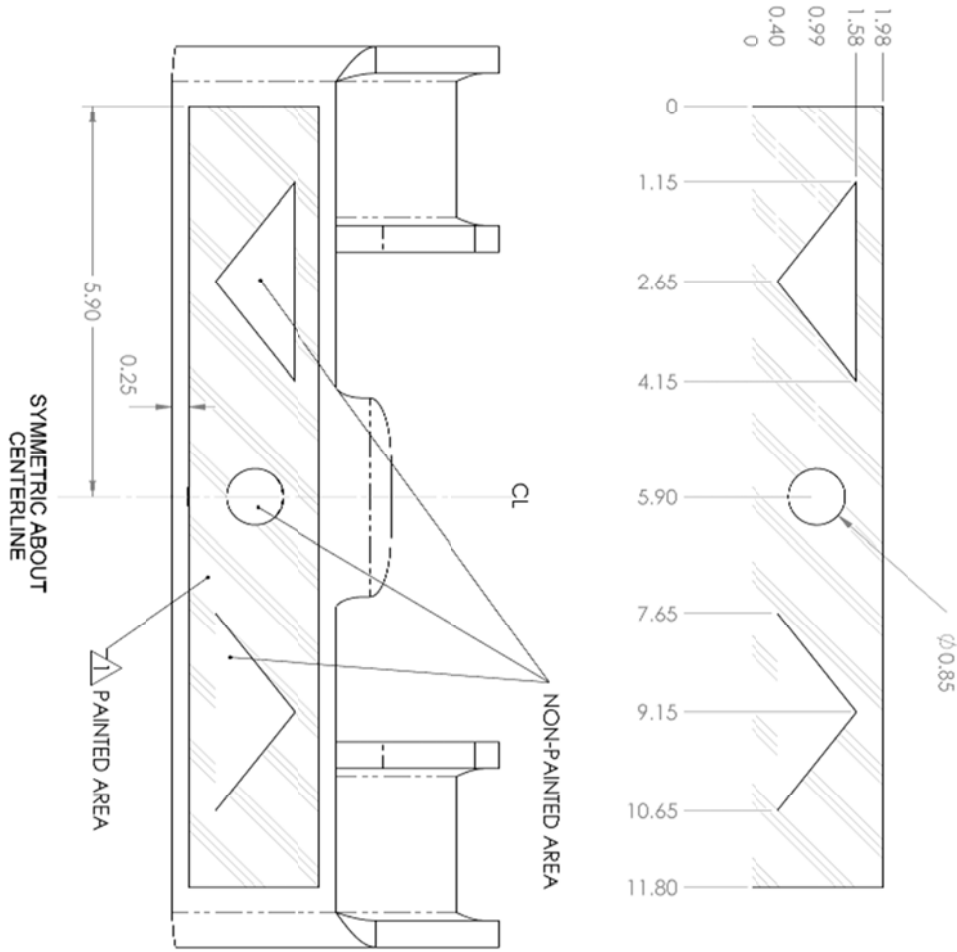

NOTES:  
 /A SURFACE MUST BE FREE FROM SCRATCHES, DERRIS, AND OTHER CONTAMINANTS.

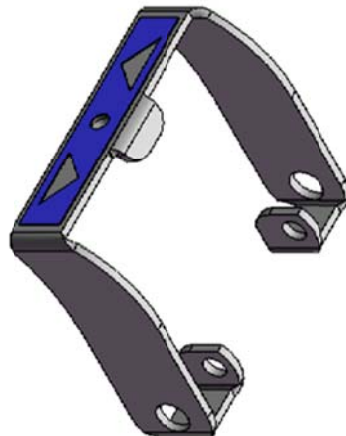

**Assembly Instructions**

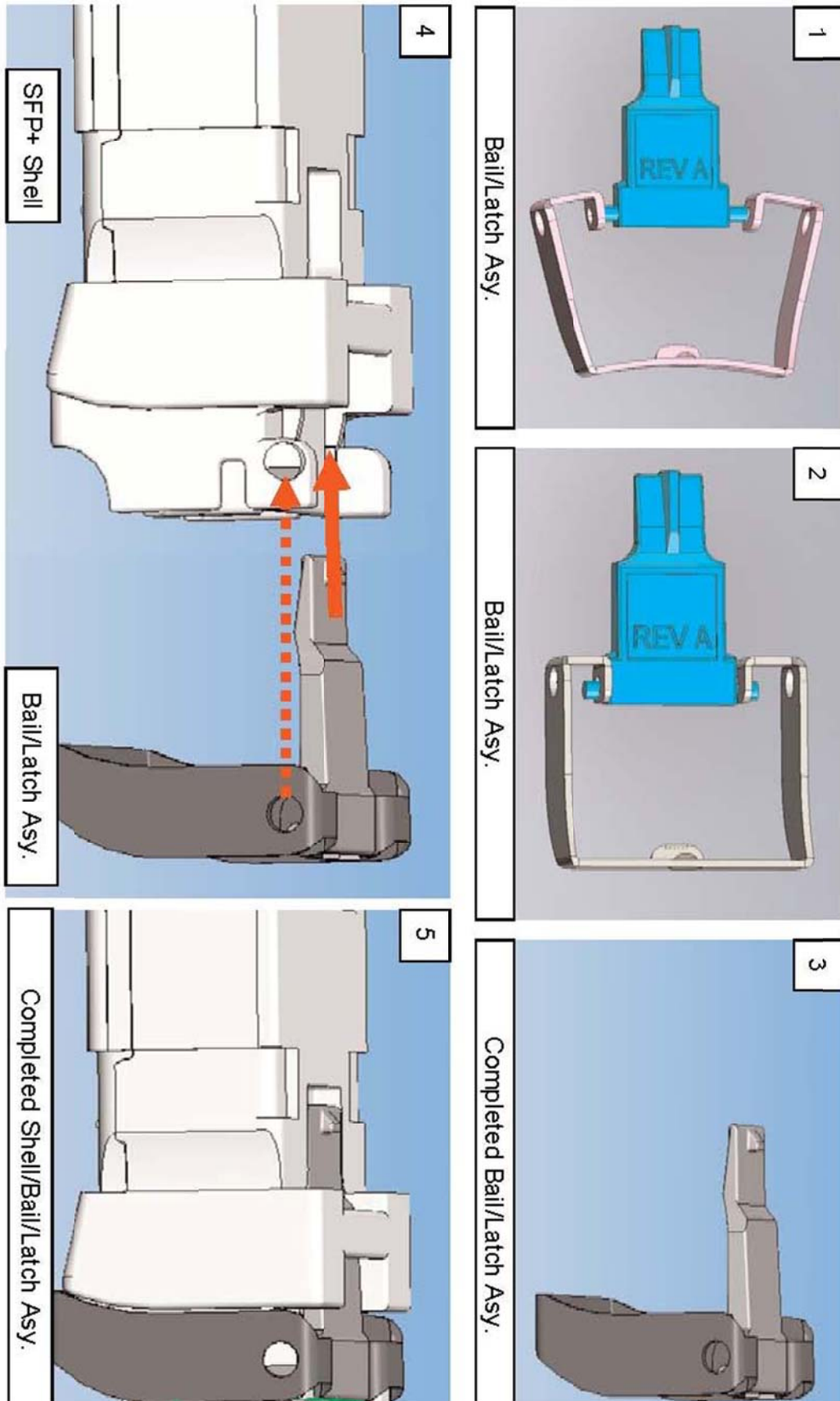



**Revision History**

<b>Revision</b>	<b>Date</b>	<b>Description</b>
N	4/13/2013	• Finisar Datasheet format

**XII. For More Information**

Finisar Corporation  
1389 Moffett Park Drive  
Sunnyvale, CA 94089-1133  
Tel. 1-408-548-1000  
Fax 1-408-541-6138  
[sales@finisar.com](mailto:sales@finisar.com)  
[www.finisar.com](http://www.finisar.com)

## X-ON Electronics

Largest Supplier of Electrical and Electronic Components

*Click to view similar products for [Fiber Optic Connectors](#) category:*

*Click to view products by [Finisar](#) manufacturer:*

Other Similar products are found below :

[0004700001](#) [6100-R](#) [6313](#) [F709034706](#) [F709722200](#) [F709730000](#) [F718183204](#) [F727403500](#) [F727752800](#) [FCXO-12-3BY](#) [FO-SCREW\(M2X6\)](#) [9440F20-27S-190](#) [944-120-6001](#) [944-125-6003](#) [9441F10SL-3P](#) [953-101-5310-P](#) [954-101-57202B](#) [A0270169](#) [12-9122](#) [12-5702](#) [143025NC](#) [DSAKB](#) [AX101713](#) [AX102420](#) [AX103923](#) [AX104193](#) [AX104230](#) [AX104562](#) [AX104683](#) [AX105203-B25](#) [AX105205-S1](#) [EHSC2M](#) [17-300800](#) [180-044NF06-11-2S](#) [180-044NF06-17-8P](#) [180-044NF07-11-2S](#) [181-011-126](#) [181-011-S](#) [181-057-126](#) [BT34IW](#) [HRFCP-HSCJ-1\(61\)](#) [HRFC-R2\(40\)](#) [NKSOPBUY](#) [20500002116](#) [2064996-1](#) [20800001065](#) [2170](#) [9132](#) [2612](#) [2620](#)