

HerkuleX

DRS-0101 / DRS-0201

User Manual



CONTENT

1. Safety Instructions

1-1. Meaning of Symbols	03p
1-2. Operating Precautions	03p
1-3. Safe Battery Handling	04p
1-4. Safe Storage	04p

2. Introduction

2-1. Parts List	05p
2-2. Product Overview	06p
2-3. Specification	09p

3. Assembly Instructions

3-1. Joint Assembly	10p
3-2. Joint Assembly(Optional Bracket and Bolt Required)	12p
3-3. Connector Pin & System Assembly	17p

4. Operation

4-1. Communication Protocol	18p
4-2. Register Map	21p

5. Command Set

5-1. [To Servo Module] – Request Packet	40p
5-2. [To Controller(ACK)] – ACK Packet	40p
5-3. CMD(Command) Details	41p

6. Command Examples

42p

Referenace

51p

1. Safety Instructions

Thank you for purchasing our HerkuleX.

For your safety, please read the instruction manual before using the HerkuleX with particular attention to the safety instructions below.

1-1. Meaning of Symbols

Any sections within the manual with the following symbols require special attention to safety.



Danger

Ignoring the instructions with this symbol can lead to serious bodily injury or death to the user and to those near by and high possibility of damage to the property and equipment.



Warning

Ignoring the instructions with this symbol can lead to possible bodily injury and death to the user and to those near by and high possibility of damage to the property and equipment.



Caution

Ignoring instructions with this symbol may risk bodily injury.



Strictly Prohibited



Compulsory requirement

1-2. Operating Precautions



Caution



Do not disassemble or modify the servo.



Do not use power sources other than the recommended battery.



Do not touch the servo casing immediately after the operation.



Keep away from water, sand, and dust.



Do not use the servo for purposes other than installation in the indoor robot.



Do not use overt force to turn the servo horn.



Servo should not be left if locked position.

1-3. Safe Battery Handling



Warning



Always use the appropriate battery charger to charge the battery pack.



Do not connect the battery packs in parallel configuration.



Never disassemble or modify the battery pack.



Do not use the battery pack with apparent external damage.

1-4. Safe Storage



Caution



To prevent accidents and damage, do not store the servo under the conditions listed below

- Location with temperatures above 60 degree celsius or below 20 degree celsius.
- Location with direct sunlight.
- Location with high humidity.
- Area with vibration.
- Dusty area.
- Area with possible electrostatic electricity,
- Area within easy reach of children.

2. Introduction

2-1. Parts List

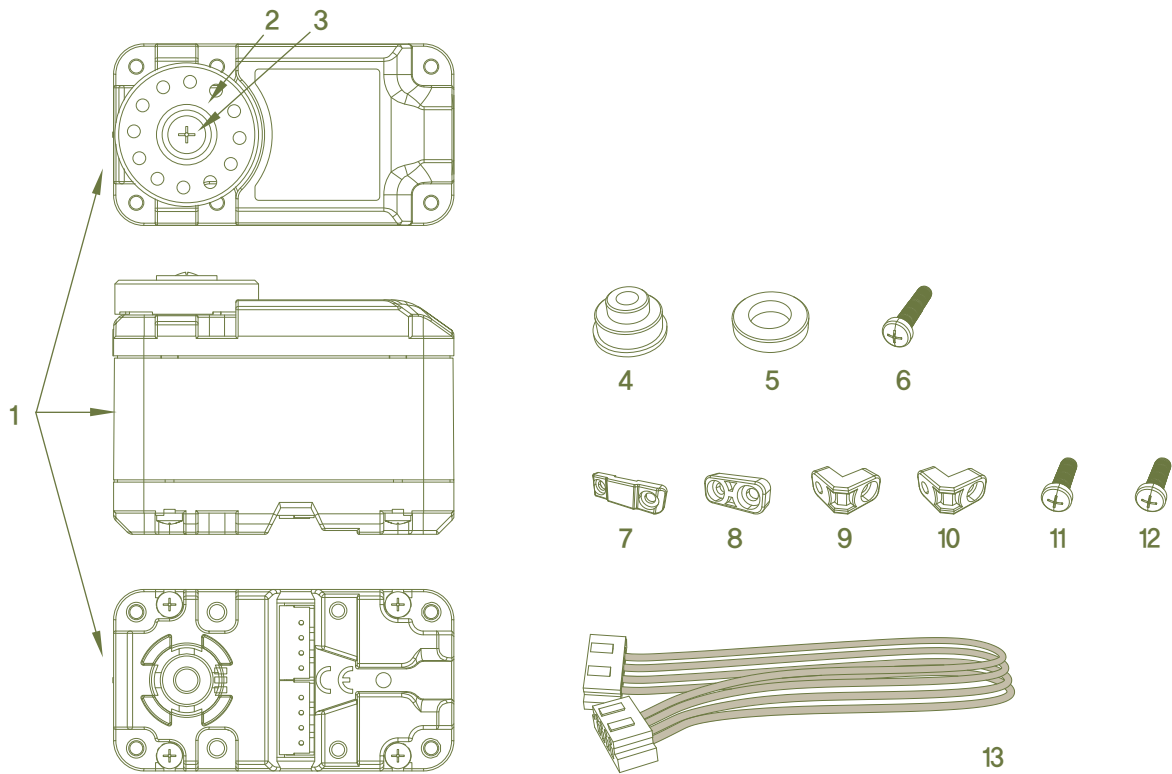

1	Servo	: 1ea
2	Horn	: 1ea
3	Horn Bolt(BHT 2.6X8)	: 1ea
4	Wheel Horn Bushing	: 1ea
5	Wheel Horn Washer	: 1ea
6	Wheel Horn Bolt(PHM 3X8)	: 1ea
7	Cable Guard	: 2ea
8	I-type Joint	: 2ea
9	L-type Joint	: 2ea
10	L-type Joint(Single Nut)	: 4ea
11	Bracket Bolt(PHT 2X5)	: 4ea (※ DRS-0201 replaced by PHM 2X5)
12	Joint Bolt(PHM 2X5)	: 12ea
13	Wire Harness(200mm)	: 1ea

2-2. Product Overview

Smart Servo

DRS-0101 and DRS-0201 are state of the art modular smart servos incorporating motor, gear reducer, control circuitry and communications capability in one single package. Both servos are capable of detecting and responding to internal changes in temperature and voltage supply.

Simple Assembly and Wiring

Small, light, and easy to assemble structure. Our servos make joint assembly an easy job with an added advantage of simple wiring. Two connectors attached to each servo allows serial connection as well as parallel connection if required.

Highest Stall Torque in relation to Size and Power

In relation to size, weight, and power requirement, our servos have the highest stall torque in its class.

Versatility from Two Different Models

By introducing two different models of the same size but with different torque and speed, our customers have the choice to choose and mix and match the servos to assemble custom joints.

- DRS-0101 : Stall Torque 12kgf.cm @7.4DCV [166.8 ozf.in.], Speed 0.166s/60°@7.4DCV
- DRS-0201 : Stall Torque 24kgf.cm @7.4DCV [333.6 ozf.in.], Speed 0.147s/60°@7.4DCV

Smooth Movement

Once the servo receives a movement command, it automatically creates a trapezoidal type speed profile like the diagram below to control the position. With the servo operating according to the acceleration/deceleration profile, it suppresses vibrations caused by the sudden acceleration and deceleration as found in the square type speed profile and increases the energy efficiency while leading to smoother movement. The servo chooses the trapezoidal type speed profile as a default but profile could be changed according to usage to trapezoidal type, square type or triangle type.

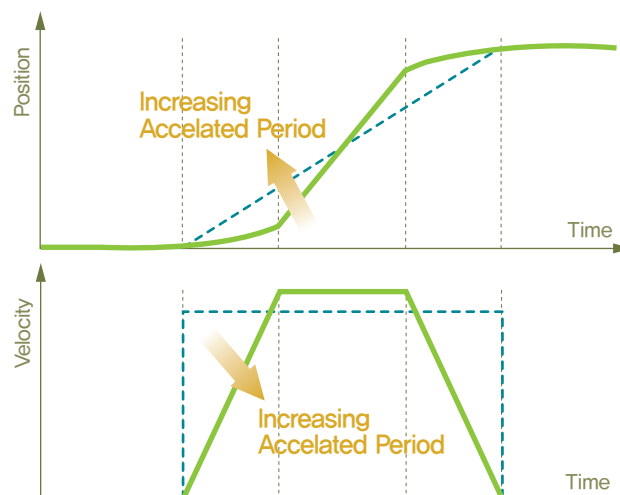

Durability

Manufactured using Super Engineering Plastic, our servos are highly durable, impact resistant and designed to withstand even the high torque stress levels that go beyond the tolerance specs of Engineering Plastic Gears.

Communication

Using Multi Drop TTL Full Duplex UART Serial communications protocol with maximum speed of 0.667Mbps, single command can set the speed, position, LED, operational compliance, stop and operational status of up to 254 servos simultaneously at once.

54 Operating Parameters

Operational parameters such as speed, calibration, compliance to external force, LED could be set by writing directly to the register, by using the Servo Manager downloaded from the web site or by using the Servo Manager Kit sold separately.

Resolution

0.325 degrees resolution provides very accurate smooth control and minimal vibration.

Maximum Operating Angle

- Position Control Mode : 0 ~ 320° possible but recommended range is within 0 ~ 300°
- Speed Control Mode : Continuous rotation possible with rotation speed control

Compliance Control

By controlling the torque according to the discrepancy between the goal position and the actual position, Compliance Control provides certain measure of elasticity to absorb the shock from the external force.

Data Feedback

Data feedback from the internal temperature, position, and overload sensors.

Protection Features

- Internal temperature sensor monitors the motor and the circuit temperature and issues Overheating Protection Error if the temperature moves beyond set value.
- Overload Protection Error is issued when the load stress on the servo goes beyond the set value. These safety features protect the servo from the potential damage and prolongs the servo life.

Self Diagnosis

Servos are capable of diagnosing seven different types of errors which are then indicated by the LED. Servo UI is used to set the function and timing of the Overload Protection. (protects the servo when the overload occurs by releasing the torque)

Multi Drop Network

Expandable Multi Drop type Network with 1:n configuration. (single controller connected to multiple “n” number of servos).

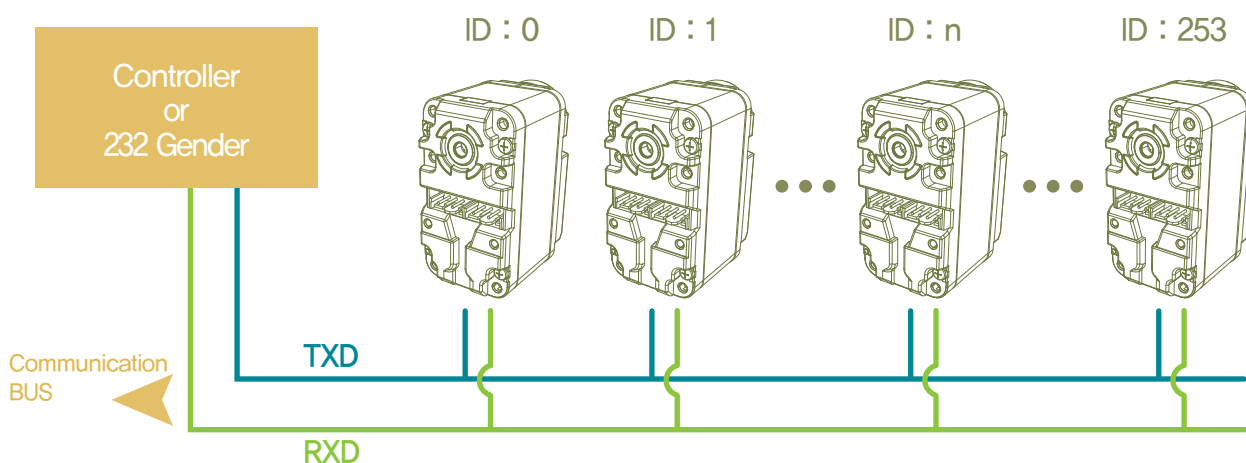

Multi Function LED

User has direct control the three independently controlled LEDs Red/Green/Blue which are used for diagnostics and decorative purposes. LED commands are sent together with the Operation command.

※ In case of an error, diagnostics function ignores all LED commands and the Red LED starts to blink periodically according to the setting.

Metal Ball Bearing (DRS-0201)

Ball bearing installed on the 4th gear shaft will prevent wear, sloping and provide protection from external shocks that can bend the shaft or throw the gear out of mesh.

- ※ DRS-0101 : Plastic Bushing
- ※ DRS-0201 : Metal Ball Bearing

2-3. Specification

Dimension / Weight	45mm(W) x 24.0mm(D) x 31mm(H) / 45g [1.59 oz] 45mm(W) x 24.0mm(D) x 31mm(H) / 60g [2.12 oz] (DRS-0201) [1.77 in.(W) x 0.94 in.(D) x 1.22 in.(H)]
Reduction Ratio Gear Material	1 : 266 Super Engineering Plastic, Heavy Duty Metal (DRS-0201)
Input Voltage Rated Current Motor	7~12VDC(Optimized 7.4V) 450mA @ 7.4V : 1.7kgf.cm, 670mA @ 7.4V : 2.2kgf.cm (DRS-0201) Carbon Brush Cored DC, Metal Brush Coreless DC (DRS-0201)
Stall Torque / Maximum Speed	12kgf.cm [166.8 ozf.in.] / 0.166s/60 ° @7.4V 24kgf.cm [333.6 ozf.in.] / 0.147s/60 ° @7.4V (DRS-0201)
Resolution	0.325 °
Operating Angle Temperature	320 ° , Continuous Rotation 0 ~ 85°C [32°F~185°F]
Communication Link ID, Maximum Baud Rate	Full Duplex Asynchronous Serial(TTL Level), Binary Packet, Multi Drop 0 ~ 253, 254(Broadcast only) 0.67Mbps
Feedback	Position, Speed, Temperature, Load, Voltage etc.
Control Algorithm	PID, Feedforward, Trapezoidal Velocity Profile, Velocity Override, Torque Saturator & Offset, Overload Protection, Neutral Calibration, Dead Zone 54 Selectable Setting Parameters(※ Servo Manager Kit Required)

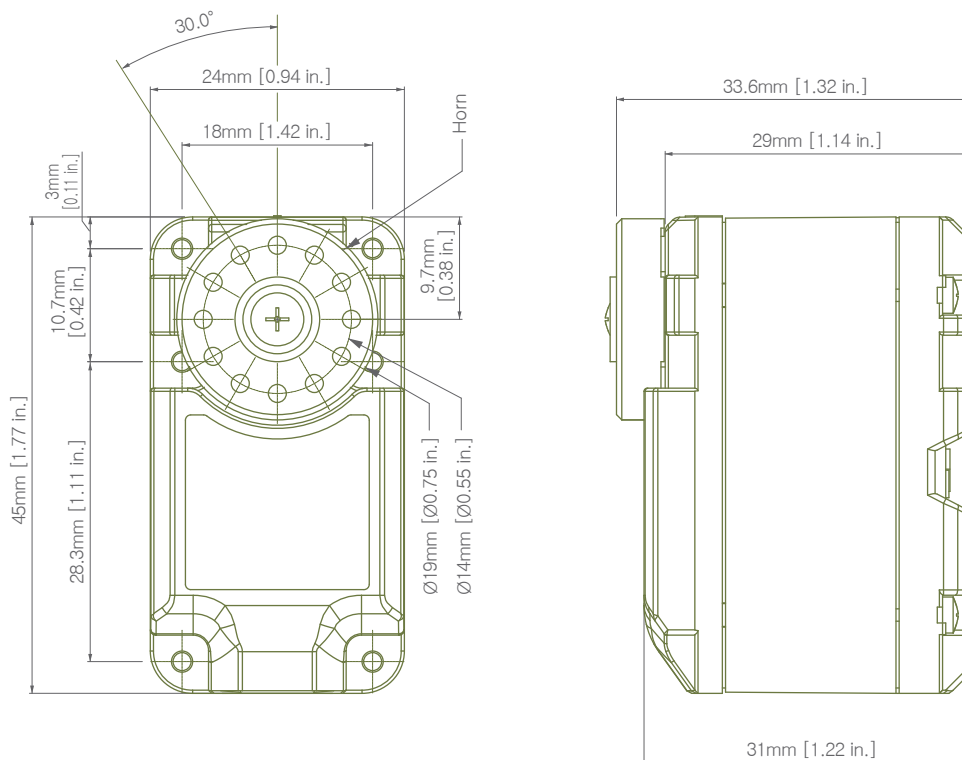

※ Refer to Pages 51 and 52 for connector specs.

3. Assembly Instructions

3-1. Joint Assembly

TYPE 1

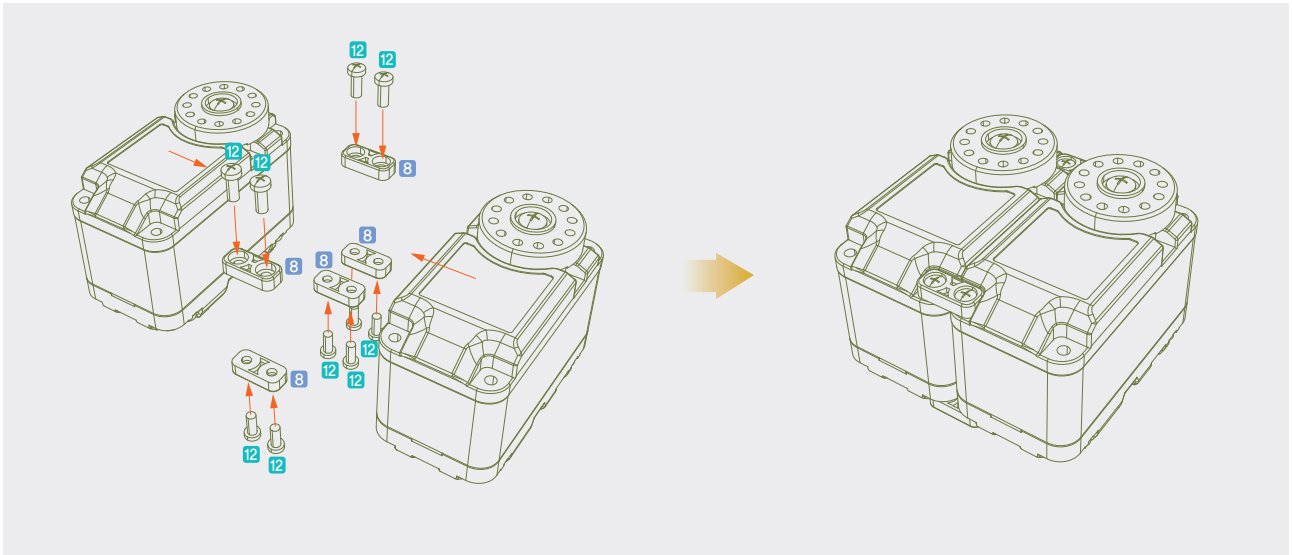

Assembly Diagram

Assembled Unit

TYPE 2

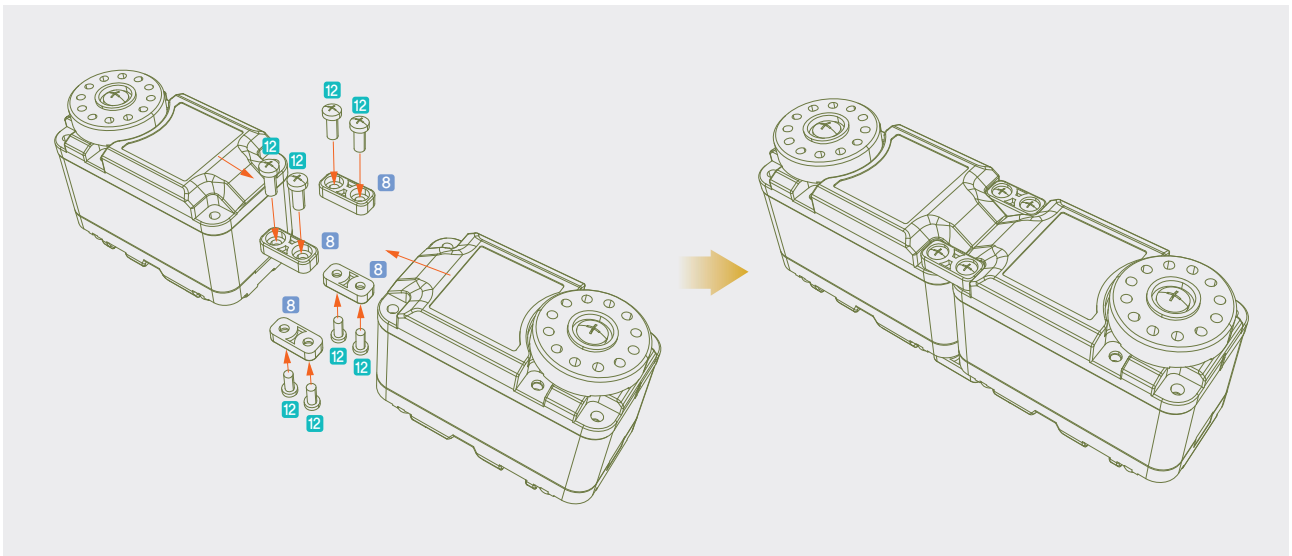

Assembly Diagram

Assembled Unit

TYPE 3

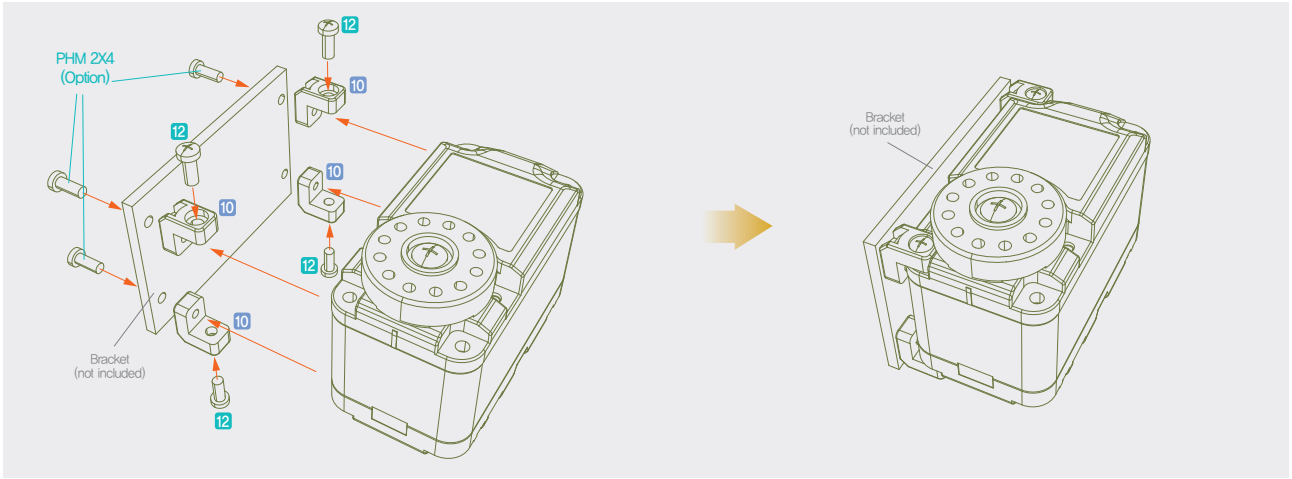

Assembly Diagram

Assembled Unit

TYPE 4

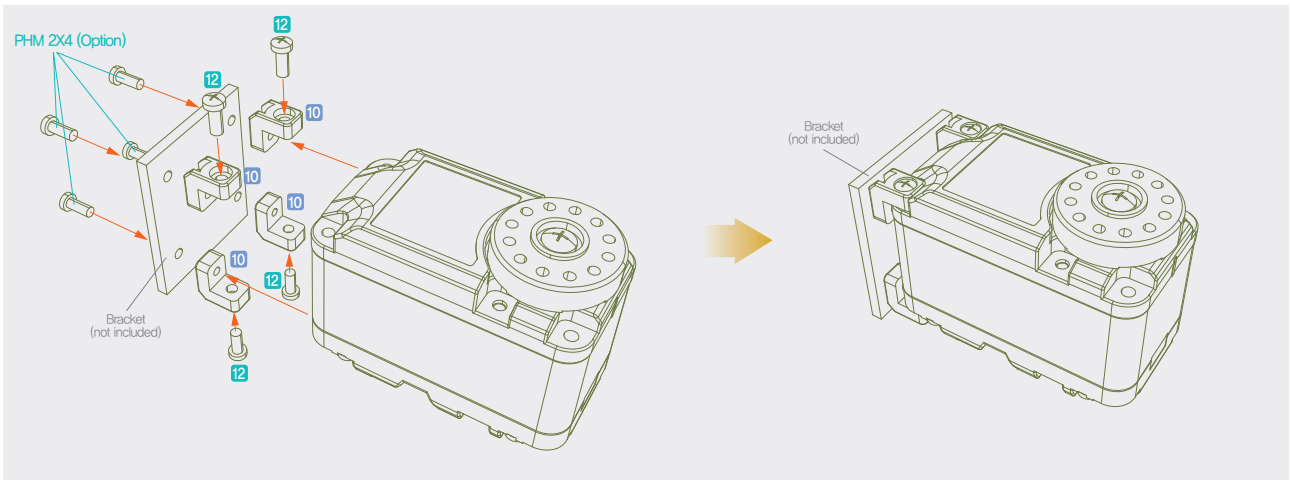

Assembly Diagram

Assembled Unit

TYPE 5

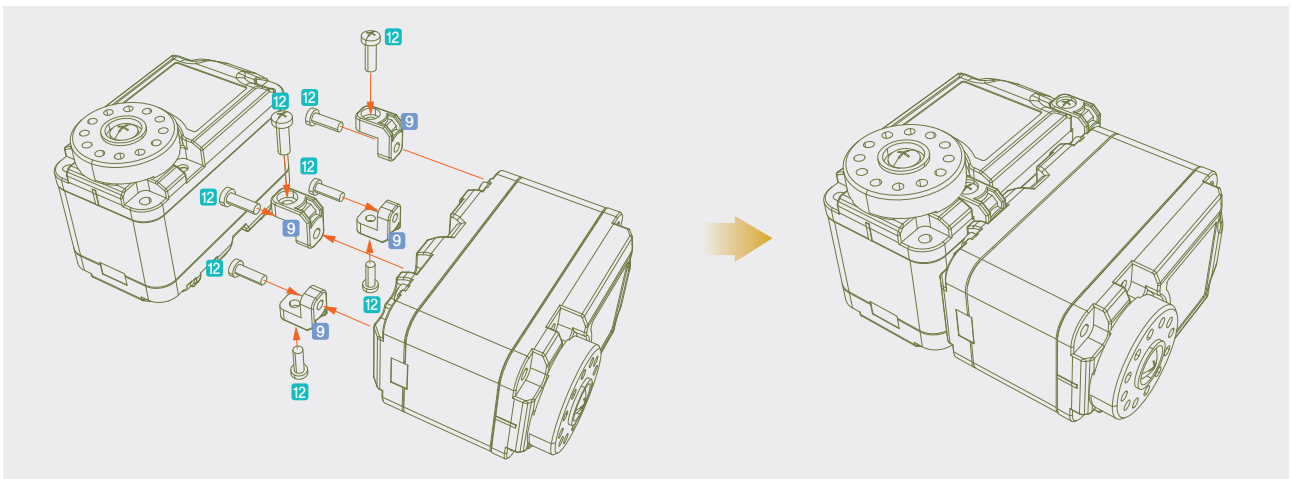

Assembly Diagram

Assembled Unit

3-2. Joint Assembly (Optional Bracket and Bolt Required)

TYPE 1

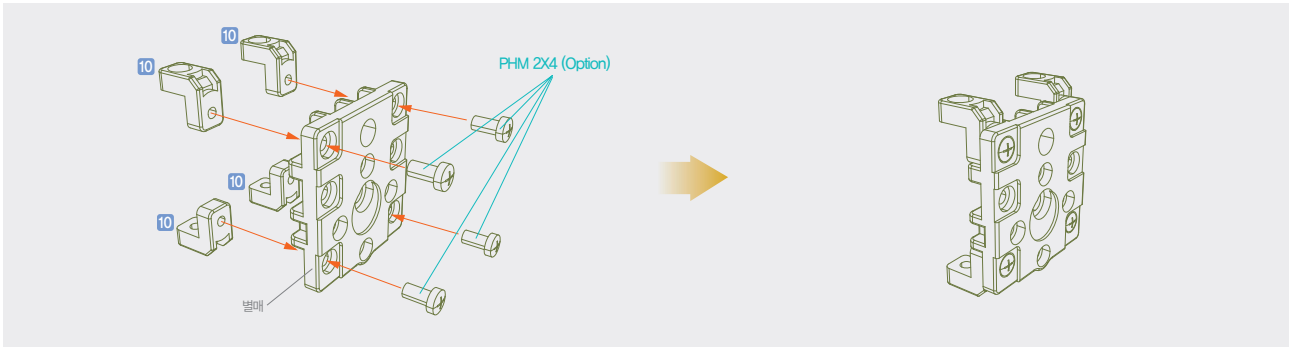

Assembly Diagram

Assembled Unit

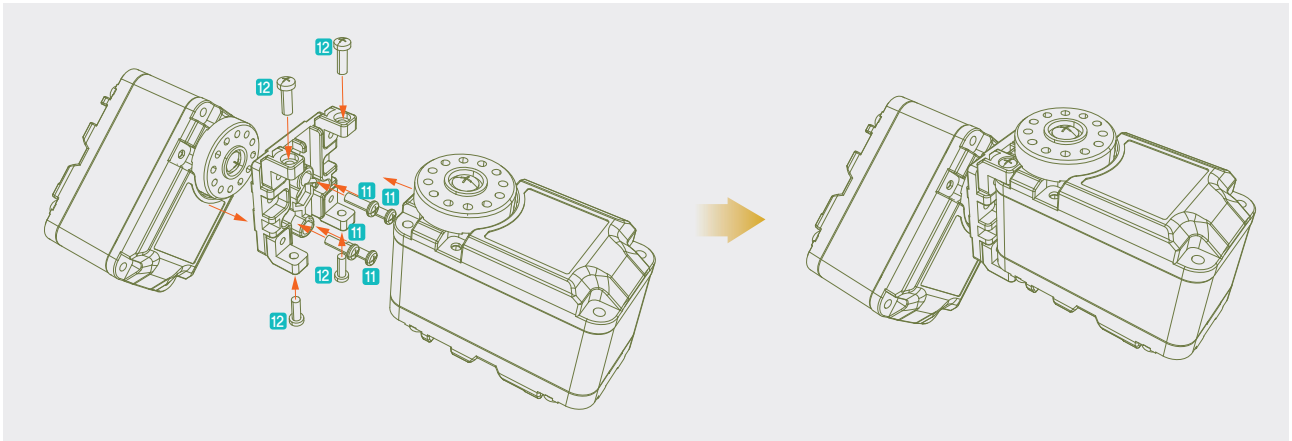

Assembly Diagram

Assembled Unit

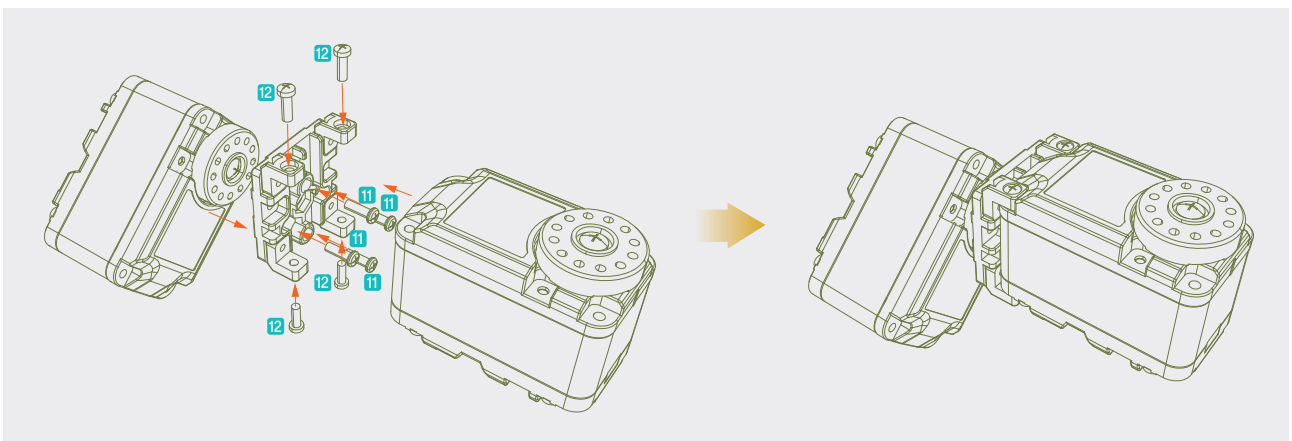

Assembly Diagram

Assembled Unit

TYPE 2

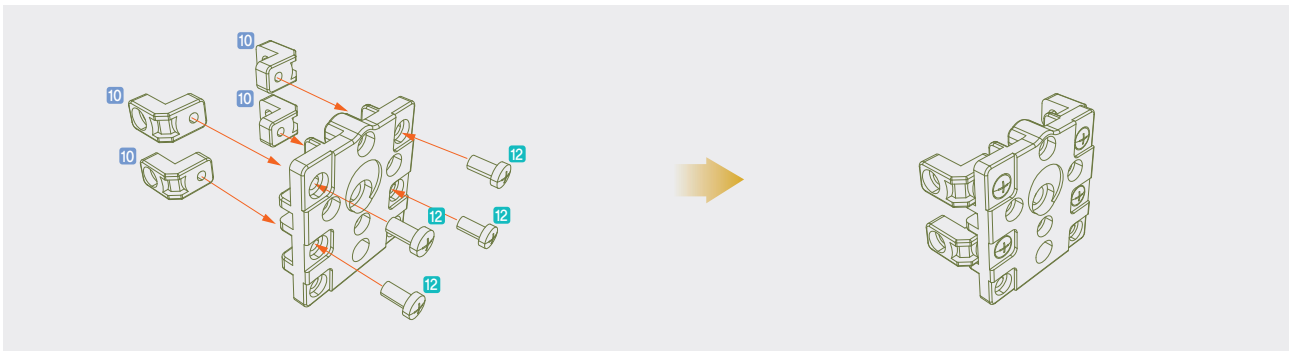

Assembly Diagram

Assembled Unit

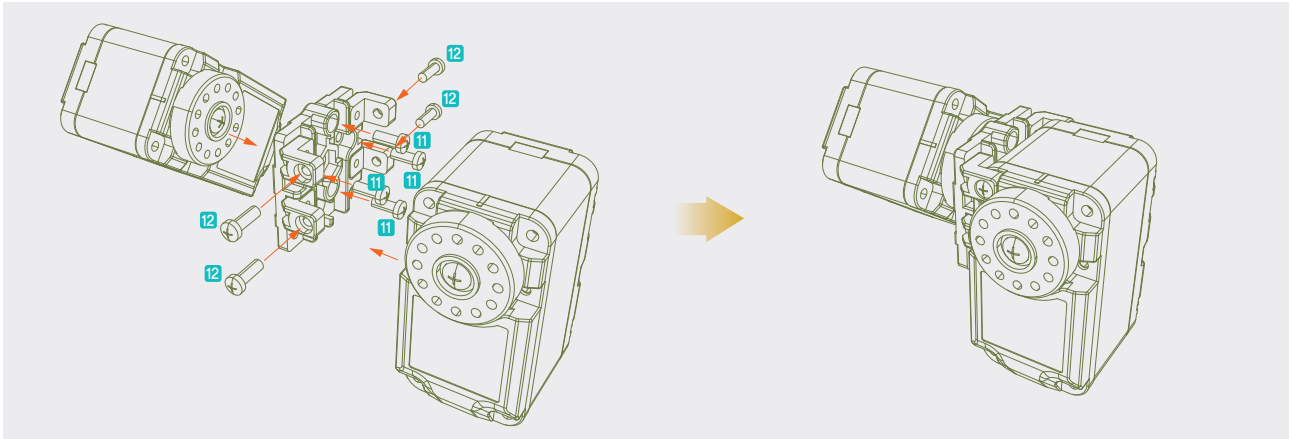

Assembly Diagram

Assembled Unit

TYPE 3

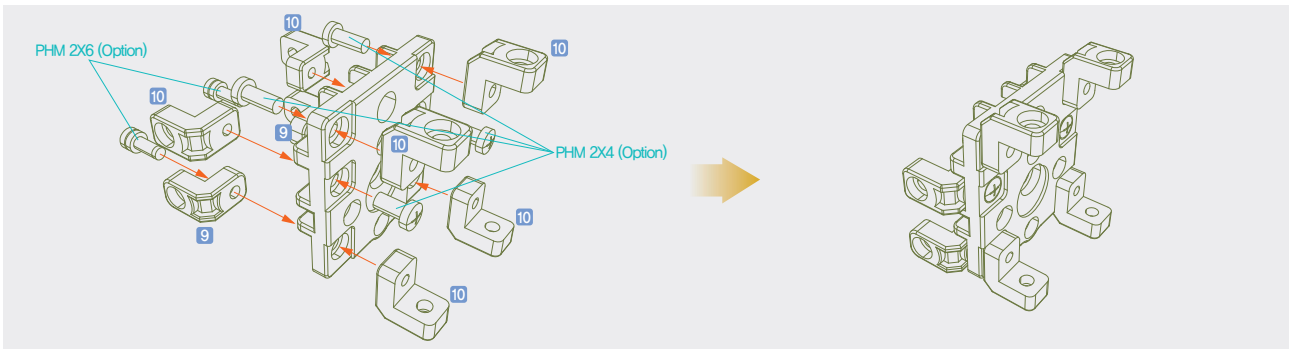

Assembly Diagram

Assembled Unit

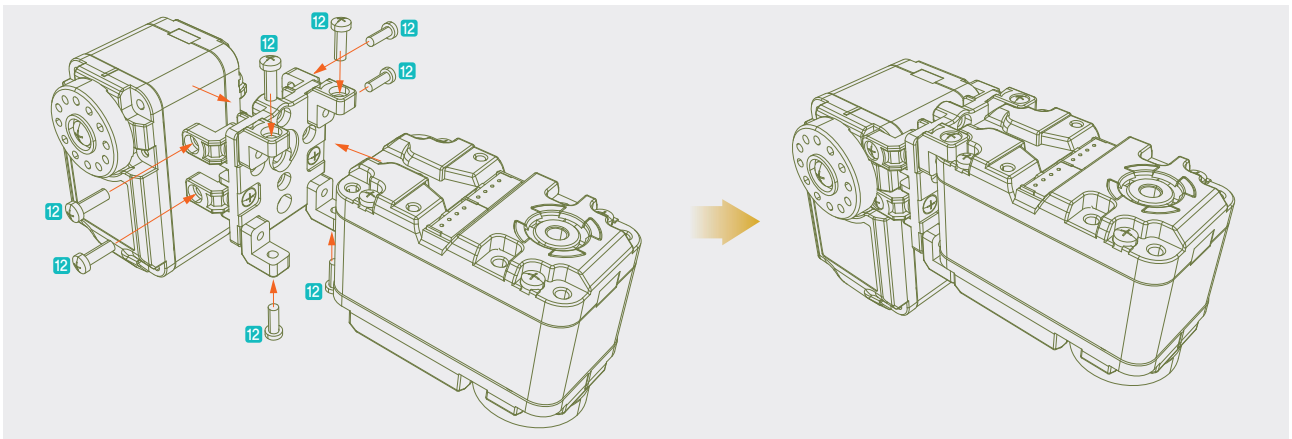

Assembly Diagram

Assembled Unit

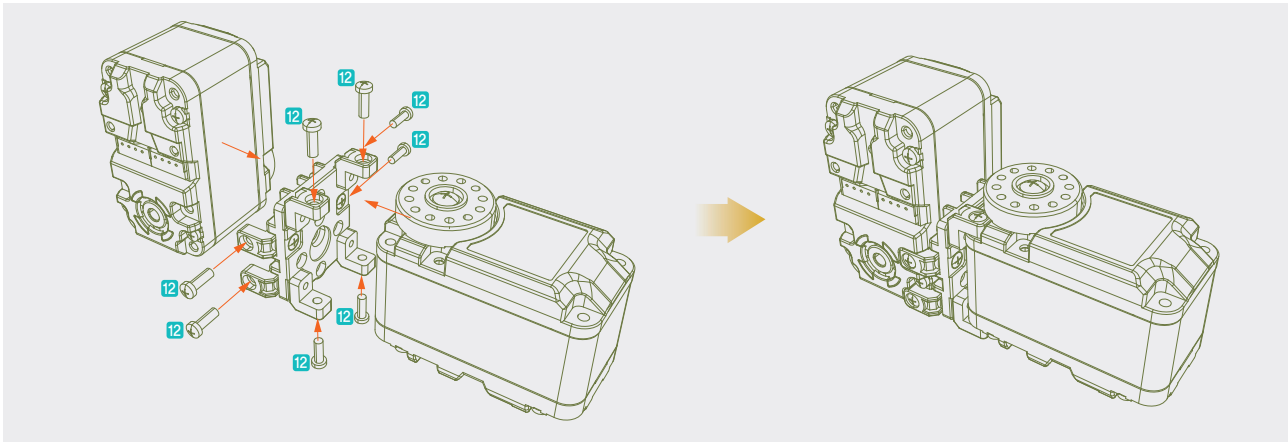

Assembly Diagram

Assembled Unit

TYPE 4

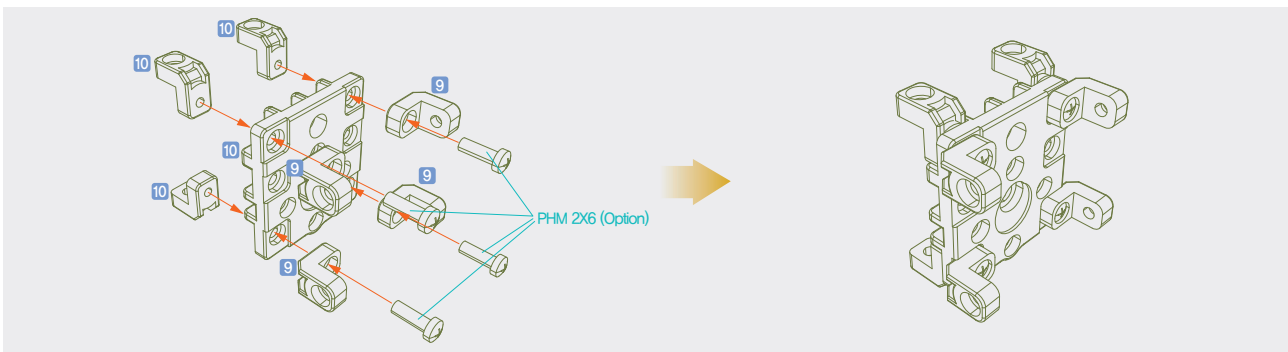

Assembly Diagram

Assembled Unit

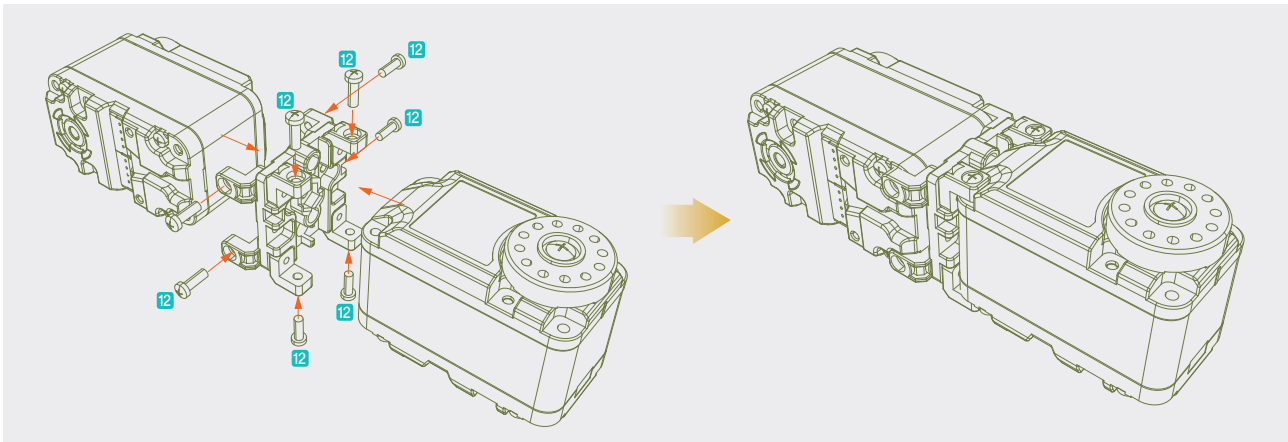

Assembly Diagram

Assembled Unit

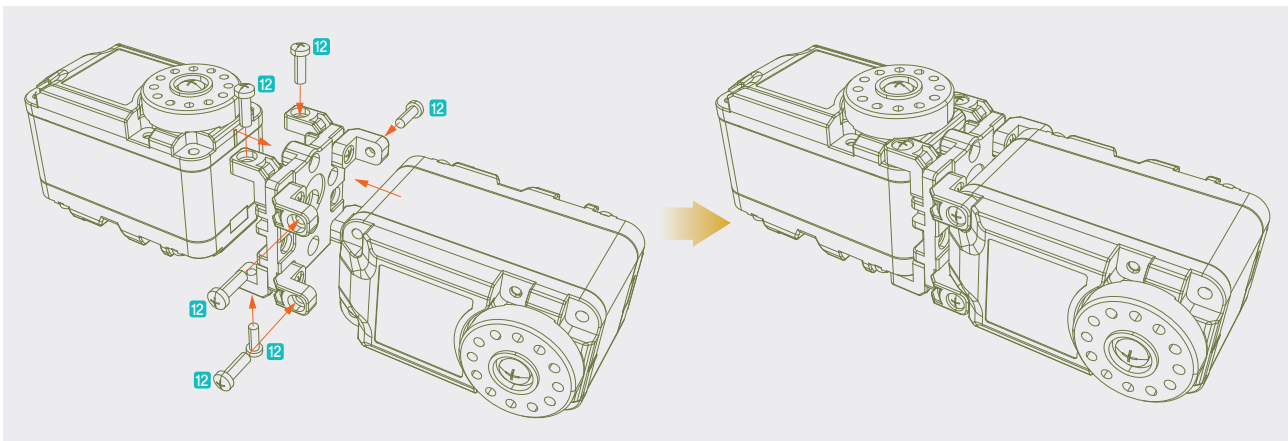

Assembly Diagram

Assembled Unit

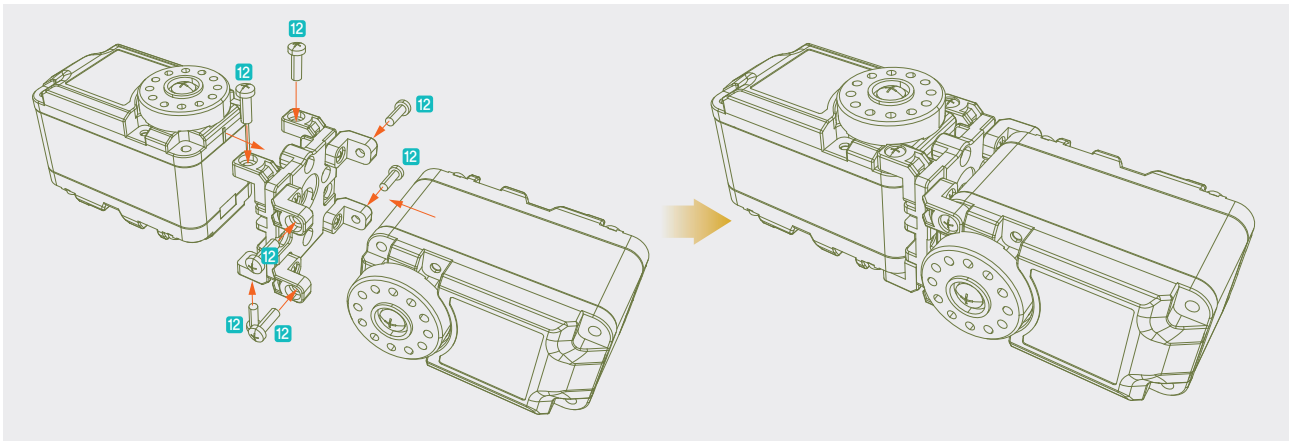

Assembly Diagram

Assembled Unit

TYPE 5

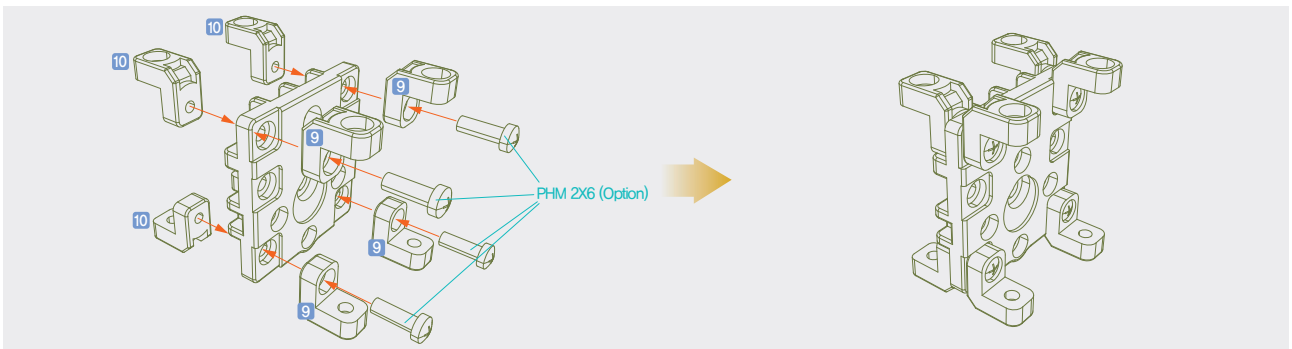

Assembly Diagram

Assembled Unit

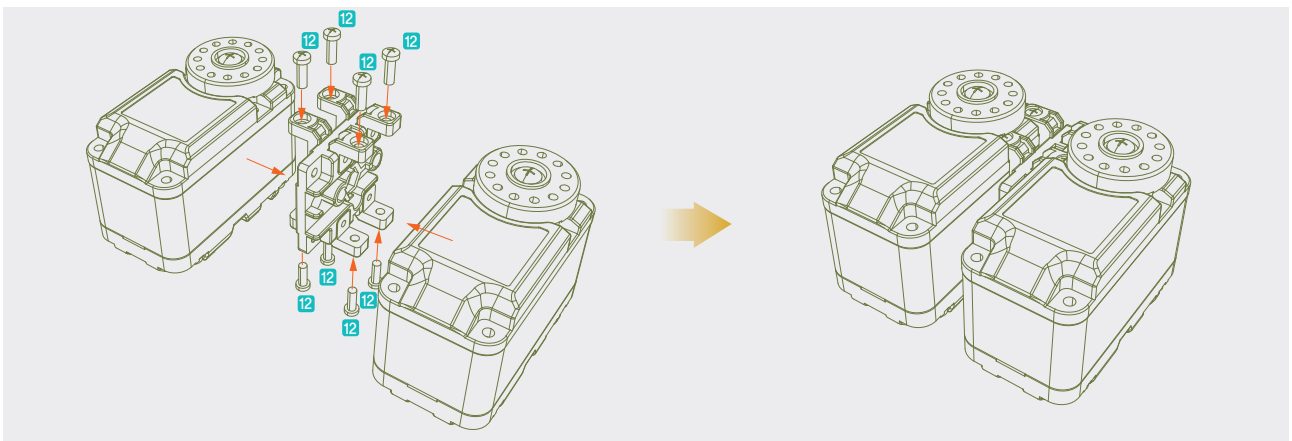

Assembly Diagram

Assembled Unit

TYPE 6

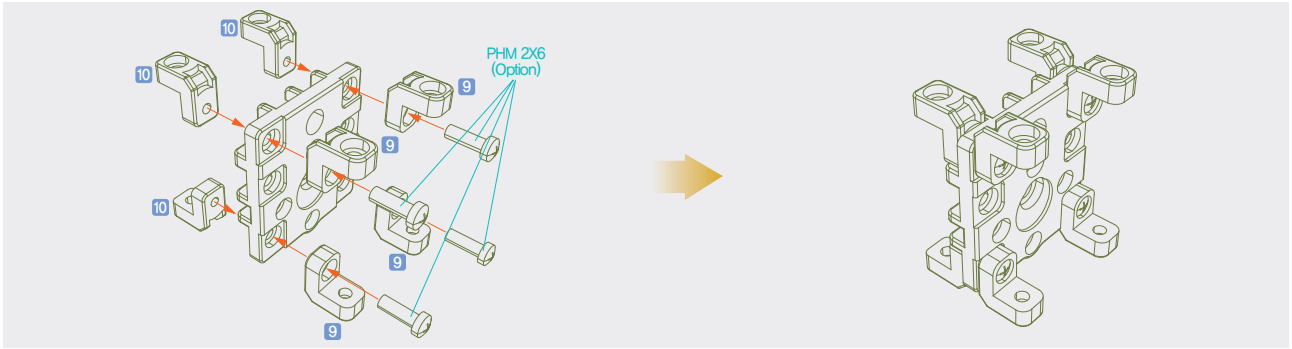

Assembly Diagram

Assembled Unit

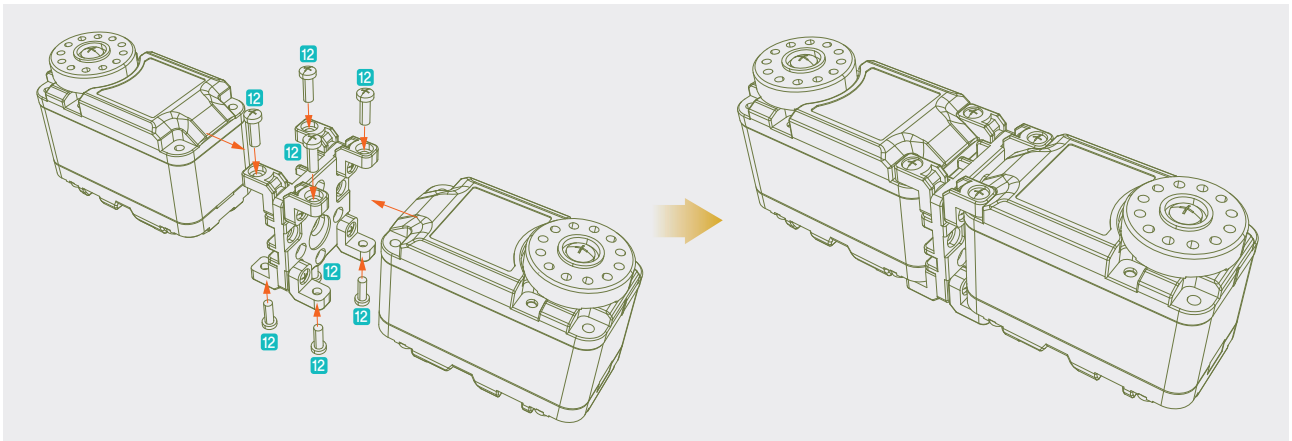

Assembly Diagram

Assembled Unit

TYPE 7

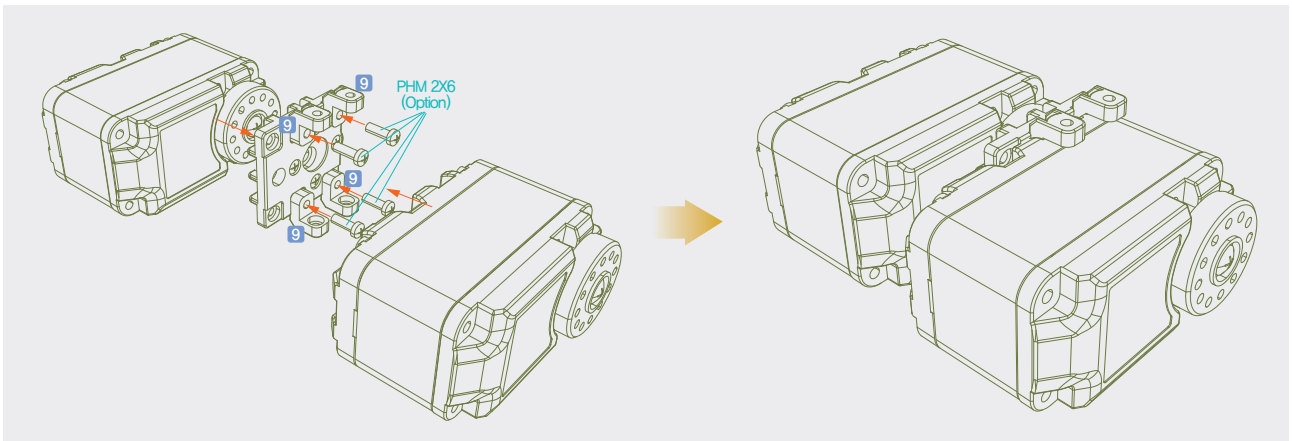

Assembly Diagram

Assembled Unit

3-3. Connector Pin & System Assembly

All the Servo to Servo connectors have same Pin assingment as the diagram below. Multi Drop Network makes expansion easy.

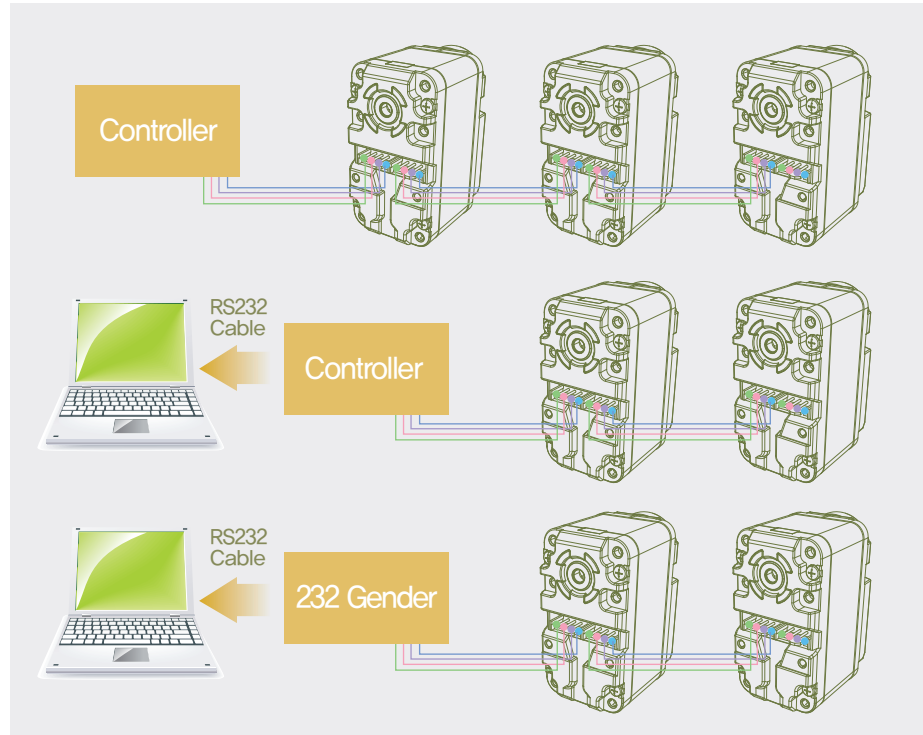
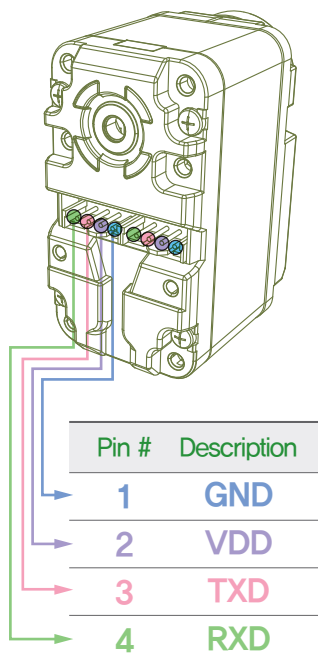

! Caution

Servos must be cross connected to the PC or Motion Controller. Examples of cross connection would be Servo TXD to PC or Motion Controller RXD, Servo RXD to PC or Motion Controller TXD.

! Caution

Do not connect the servo directly to the PC without using the Motion Controller or Signal Converter. Even though both PC and the servo uses serial protocol (TXD, RXD) they are not directly compatible due to electrical difference.

! Caution

If using custom made Wire Harness, make sure to check that connector pin assignments are in correct order. Servo LED will blink once if it is receiving power properly. If the LED does not blink, check the connector pin assignment and the power supply Voltage and Amp.

4. Operation

4-1. Communications Protocol

Introduction

Servo Controller communicates with the servos in the network by sending a Request Packet and receiving ACK Packet back from the servo. The example below shows the controller sending a Request Packet to the Servo n and receiving ACK packet back from the Servo n. Regardless of the number of servos in the network, only the servo with correct ID (n) will acknowledge the Request Packet and send the ACK Packet to the controller.

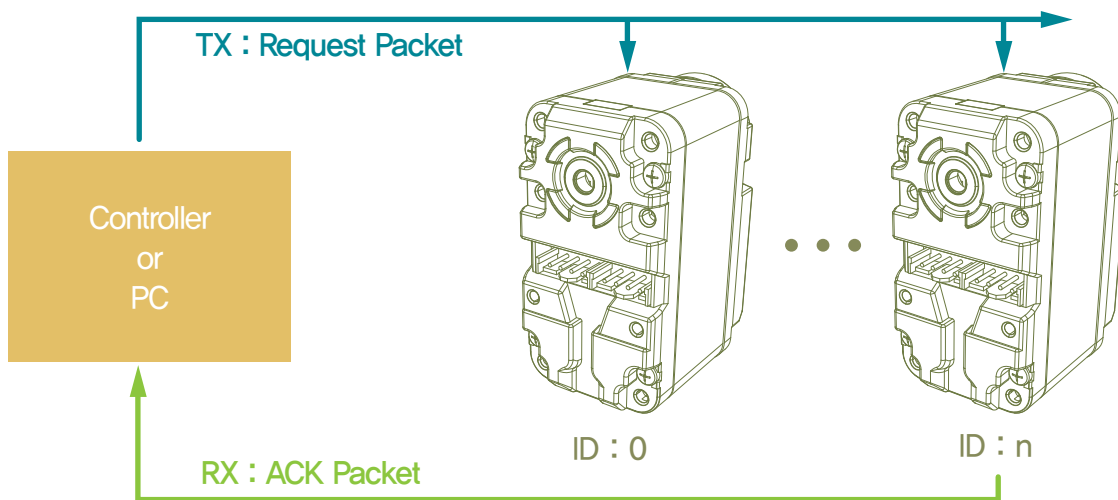

Communication Protocol

Data Bit : 8
 Stop Bit : 1
 Parity : None
 Flow Control : None
 Baud Rate : 57,600 / 115,200 / 0.2M / 0.25M / 0.4M / 0.5M / 0.667M

※ The communications speed of the PC communication ports or USB to Serial Cable can be limited by the hardware or by the device driver. If problem occurs, check the Baud Rate of the involved port of peripheral to make sure it supports 115,200bps. If the supported Baud Rate can not found, set the Baud Rate to 115,200bps or 57,600bps and try again. The default factory setting for DRS-0101 and DRS-0201 is 115,200bps.

Packet

Type	Header		Packet Size	pID	CMD	Check Sum1	Check Sum2	Data[n]
Value	0xFF	0xFF	7~223	0~0xFE	1~9	Refer to Detail	Refer to Detail	Refer to Detail
Byte	1	1	1	1	1	1	1	MAX 216

► Header

Indicates start of the Packet.

Type	Header	
Value	0xFF	0xFF
Byte	1	1

► Packet Size

Refers to total Packet size (in Bytes) from Header to Data. The maximum Packet Size 233, if the packet size is larger than 223 Bytes, packet may not be recognized. Minimum packet size is 7 which is packet without any data.

► pID

Unique pID value can range from 0 ~ 253 which is total number of servos in the network. Care must be taken when using pID value of “0xFE” which is a special value that affects all the servos in the network.

※ To avoid confusion with Servo ID, ID within the packet is denoted pID

Type	pID
Value	0 ~ 0xFE
Byte	1

► CMD

CMD is actual instructions for the servo to perform when packet is received. There are 9 types of CMD in Request Packet EEP_WRITE(0x01), EEP_READ(0x02), RAM_WRITE(0x03), RAM_READ(0x04), I_JOG(0x05), S_JOG(0x06), STAT(0x07), ROLLBACK(0x08), REBOOT(0x09). ACK Packet also has equivalent set of CMD, but to distinguish from the Request CMD, ACK Packet adds 0x40. For example, ACK Packet CMD for Request Packet EEP_WRITE(0x01) would be 0x41.

Type	CMD
Value	0x01 ~ 0x09 : Request Packet 0x41 ~ 0x49 : ACK Packet
Byte	1

► Check Sum1

Check Sum1 is used to check for errors in the Packet. Check Sum1 is calculated as follows,
 $\text{Check Sum1} = (\text{PacketSize} \wedge \text{pID} \wedge \text{CMD} \wedge \text{Data}[0] \wedge \text{Data}[1] \wedge \dots \wedge \text{Data}[n]) \& 0xFE$.
Header, Check Sum1, Check Sum2 are not included in the calculation.

※ 'A ^ B' : Bit Exclusive OR Operator, A is different from B 1(True), same 0(False)

Type	Check Sum1
Value	$(\text{PacketSize} \wedge \text{pID} \wedge \text{CMD} \wedge \text{Data}[0] \wedge \text{Data}[1] \wedge \dots \wedge \text{Data}[n]) \& 0xFE$
Byte	1

► Check Sum2

Checksum2 is also used to check for errors in the Packet. Check sum2 is calculated as follows,
 $\text{Check Sum2} = (\sim \text{CheckSum1}) \& 0xFE$

※ $\sim A$: Bit Not Operator, A = 0 1(True), A = 1 0(False)

Type	Check Sum2
Value	$(\sim \text{CheckSum1}) \& 0xFE$
Byte	1

► Data[n]

Number of Data depends on CMD and some CMD may not have Data field.
Refer to CMD for details.

Type	Data
Value	Refer to CMD for details
Byte	Max216

4-2. Register Map

Register Map are values residing within the Servo and contain data pertaining to current servo status and operation. Registers are either Non-Volatile or Volatile.

Users are able to control the servos by using Request Packet and ACK Packet to either check or change the data in the Register Map.

Non-Volatile Register Map

Non-Volatile memory retains data without power. Once the power is turned on, data in the Non-Volatile memory in EEPROM Register are copied to the RAM Register which is Volatile memory. Data in the Non-Volatile memory does not have direct affect on the operation of the servo once it has been copied to the RAM Register. Rebooting the servo will again copy the data from EEPROM Register to the RAM Register.

► Address

Address refers to the address of the Register. To Read/Write to the Register, Register address must be included in the Packet.

► Default

Factory Default Value, Rollback Protocol is used to return all values to Factory Default Value.

► Valid Range

Range of valid data values servo can have. Input of data beyond the Valid Range will possibly result in unpredictable servo behavior.

► RO(Read Only), RW (Read Write)

RO refers to read only Registers. Writing to RO Register will result in error.

RO Registers hold fixed values such as Model #, Version or sensor values used for feedback.

RW refers to Registers which be both read and written to.

※ e (Reg_Name) : Refers to Reg_Name in EEPROM Register.

※ r (Reg_Name) : Refers to Reg_Name in RAM Register.

ADDRESS	Type	Bytes	Default	Valid Range	RW	Description
0	Model No1	1	0x01	—	RO	Shows DRS-0101 model # (※ For DRS-0201, Model No1 is 0x02)
1	Model No2	1	0x01	—	RO	
2	Version1	1	0x00	—	RO	Firmware Version
3	Version2	1	0x90	—	RO	

ADDRESS	Type	Bytes	Default	Valid Range	RW	Description
4	Baud Rate	1	0x10	Refer to Pg 26	RW	Communication Speed
5	Reserved	1	0x00	–	–	Reserved
6	ID	1	0xFD	0x00 ~ 0xFD	RW	Servo ID(0xFE : Can be used as Broadcasting ID, ID not assignable)
7	ACK Policy	1	0x01	0x00 ~ 0x2	RW	Refer to Pg 33
8	Alarm LED Policy	1	0x7F	0x00 ~ 0x7F	RW	Activates alarm LED according to policy
9	Torque Policy	1	0x35	0x00 ~ 0x7F	RW	Releases torque according to policy
10	Reserved	1	–	–	–	Reserved
11	Max. Temperature	1	0xDE	0x00 ~ 0xFE	RW	Maximum allowed temp(0xDF : 85°C)
12	Min. Voltage	1	0x5B	0x00 ~ 0xFE	RW	Minimum allowed voltage(0x5B : 6.714DCV)
13	Max. Voltage	1	0x89	0x00 ~ 0xFE	RW	Maximum allowed voltage(0x89 : 10DCV)
14	Acceleration Ratio	1	0x19	0x00 ~ 0x32(50)	RW	Ratio of time to reach goal position to acceleration or deceleration
15	Max. Acceleration Time	1	0x2D	0x00 ~ 0xFE	RW	Max acceleration time, 11.2ms interval Acceleration(0x2D : 504ms)
16	Dead Zone	1	0x00	0x00 ~ 0xFE	RW	Outside control/sensor range
17	Saturator Offset	1	0x00	0x00 ~ 0xFE	RW	Refer to Pg 36
18	Saturator Slope	2	0x0000	0x0000 ~ 0x7FFF	RW	Refer to Pg 36
20	PWM Offset	1	0x00	-128 ~ 127	RW	PWM Offset value Refer to Pg 37
21	Min. PWM	1	0x00	0x00 ~ 0xFE	RW	Sets minimum PWM value Refer to Pg 37
22	Max. PWM	2	0x03FF	0x0000 ~ 0x03FF	RW	Sets maximum PWM value Refer to Pg 37
24	Overload PWM Threshold	2	0x03FE	0x0000 ~ 0x7FFE	RW	Sets PWM overload treshold range Refer to Pg 34
26	Min. Position	2	0x0015	0x0000 ~ 0x03FF	RW	Minimum position value(0~1023)
28	Max. Position	2	0x03EA	0x0000 ~ 0x03FF	RW	Maximum position value(0~1023)
30	Position Kp	2	0x01B8	0x0000 ~ 0x7FFF	RW	Proportional Gain,
32	Position Kd	2	0x1F40	0x0000 ~ 0x7FFF	RW	Derivative Gain,
34	Position Ki	2	0x0000	0x0000 ~ 0x7FFF	RW	Integral Gain,
36	Position Feed forward 1st Gain	2	0x0000	0x0000 ~ 0x7FFF	RW	Refer to Pg 35
38	Position Feedforward 2nd Gain	2	0x0000	0x0000 ~ 0x7FFF	RW	Refer to Pg 35
40	Reserved	2	–	–	–	Reserved
42	Reserved	2	–	–	–	Reserved
44	LED Blink Period	1	0x2D	0x00 ~ 0xFE	RW	Alarm LED blink period accoring to policy, 11.2ms/Tick, 0x2D : 504ms
45	ADC Fault Check Period	1	0x2D	0x00 ~ 0xFE	RW	Temp/voltage error check period, 11.2ms/Tick, 0x2D : 504ms
46	Packet Garbage Check Period	1	0x12	0x00 ~ 0xFE	RW	Packet Error check period, 11.2ms/Tick, 0x12 : 201ms
47	Stop Detection Period	1	0x1B	0x00 ~ 0xFE	RW	Stop detection check period, 11.2ms/Tick, 0x1B : 302ms

ADDRESS	Type	Bytes	Default	Valid Range	RW	Description
48	Overload Detection Period	1	0x96	0x00 ~ 0xFE	RW	Overload Check Interval 11.2ms/Tick, 0x96 : 1.68s
49	Stop Threshold	1	0x03	0x00 ~ 0xFE	RW	Stop Threshold
50	Inposition Margin	1	0x03	0x00 ~ 0xFE	RW	Offset Threshold
51	Reserved	1	–	–	–	Reserved
52	Reserved	1	–	–	–	Reserved
53	Calibration Difference	1	0	-128 ~ 127	RW	Servo Compensation

※ 2 Byte Variable Byte Order : (Little Endian) Most significant byte is stored int the higher address.
 [Example] : e(Position Kp) Address is 30~31. To store 0x1234(4460), store the least significant first
 Address(30)= 0x34, and most significant digit last Address(31)=0x12

※ Intel & Alpha Processors use Little Endian, whereas most of the RISC Processors & Motorola Processors use Big Endian.

► Max. PWM, Dead Zone

- PWM is the value representing energy input to the Servo. When the energy is increased, servo torque or speed increases.
- Max. PWM : Limits maximum PWM, In other words, limits the maximum energy supplied to the Servo. Energy use is optimized by limiting the maximum torque or speed of the servo.
- Dead Zone : Servo moves to reach the exact Goal Position. When the difference (Error) between the current position and the goal position becomes 0, the force drops to 0 and the servo stops. Dead Zone provides flexibility to the servo operation by increasing the range where the force drops to 0. If the difference (Error) is less than the Dead Zone, servo assumes it has reached the goal position and stops.

※ “What does operational flexibility” mean?

In the graph below, green line is the PWM level without the Max. PWM and Dead Zone set. The yellow line is the PWM level with the Max.PWM and the Dead Zone set. The yellow line shows the PWM dropping to 0 within the Dead Zone even though Goal Position has not been reached. Looking at the right side of the graph, even though the green line is above (larger) than the Max.PWM, actual PWM value (yellow line) is within the Max.PWM.

※ Setting the Dead Zone too large will increase the discontinuous PWM section and lead to decreased controllability. Recommended Dead Zone value is below 10.



Volatile Register(RAM Register) MAP

Volatile Memory has direct affect on the operation of the Servo and reverts to default (EEP Register) value when the Servo is reboot even though RAM register value has been changed to change the servo operating parameters. Read/Write has to be performed to RAM Register value to operate the Servo, change the operating parameters or to check servo status.

ADDRESS	Type	Bytes	Valid Range	RW	Description
0	ID	1	0x00 ~ 0xFD	RW	Servo ID(0xFE : Can be used as Broadcasting ID, ID not assignable)
1	ACK Policy	1	0x00 ~ 0x2	RW	Refer to Pg 33
2	Alarm LED Policy	1	0x00 ~ 0x7F	RW	Activates alarm LED according to Policy
3	Torque Policy	1	0x00 ~ 0x7F	RW	Releases Torque according to Policy
4	Reserved	1	–	–	Reserved
5	Max. Temperature	1	0x00 ~ 0xFE	RW	Maximum allowed temp(0xDF : 85°C)
6	Min. Voltage	1	0x00 ~ 0xFE	RW	Minimum allowed voltage(0x5B : 6.714VDC)
7	Max. Voltage	1	0x00 ~ 0xFE	RW	Maximum allowed voltage(0x89 : 10VDC)
8	Acceleration Ratio	1	0x00 ~ 0x32(50)	RW	Ratio of time to reach goal position to acceleration or deceleration
9	Max. Acceleration	1	0x00 ~ 0xFE	RW	Max acceleration time, 11.2ms interval Acceleration(0x2D : 504ms)
10	Dead Zone	1	0x00 ~ 0xFE	RW	Outside control range
11	Saturator Offset	1	0x00 ~ 0xFE	RW	Refer to Pg 36
12	Saturator Slope	2	0x0000 ~ 0x7FFF	RW	Refer to Pg 36
14	PWM Offset	1	-128 ~ 127	RW	PWM Offset value Refer to Pg 37
15	Min. PWM	1	0x00 ~ 0xFE	RW	Set minimum PWM value Refer to Pg 37
16	Max. PWM	2	0x0000 ~ 0x03FF	RW	Set maximum PWM value Refer to Pg 37
18	Overload PWM Threshold	2	0x0000 ~ 0x7FFE	RW	Set PWM Overload treshold range Refer to Pg 34
20	Min. Position	2	0x0000 ~ 0x03FF	RW	Minimum position value(0~1023)
22	Max. Position	2	0x0000 ~ 0x03FF	RW	Maximum position value (0~1023)
24	Position Kp	2	0x0000 ~ 0x7FFF	RW	Proportional Gain
26	Position Kd	2	0x0000 ~ 0x7FFF	RW	Derivative Gain
28	Position Ki	2	0x0000 ~ 0x7FFF	RW	Integral Gain
30	Position Feedforward 1st Gain	2	0x0000 ~ 0x7FFF	RW	Refer to Pg 35
32	Position Feedforward 2nd Gain	2	0x0000 ~ 0x7FFF	RW	Refer to Pg 35
34	Reserved	2	–	–	Reserved
36	Reserved	2	–	–	Reserved
38	LED Blink Period	1	0x00 ~ 0xFE	RW	Alarm LED blink period according to Policy 11.2ms/Tick, 0x2D : 504ms

ADDRESS	Type	Bytes	Valid Range	RW	Description
39	ADC Fault Detection Period	1	0x00 ~ 0xFE	RW	Temp/Voltage error check interval 11.2ms/Tick, 0x2D : 504ms
40	Packet Garbage Detection Period	1	0x00 ~ 0xFE	RW	Packet Error check interval, 11.2ms/Tick, 0x12 : 201ms
41	Stop Detection Period	1	0x0000 ~ 0x7FFF	RW	Stop detection check interval, 11.2ms/Tick, 0x1B : 302ms
42	Overload Detection Period	1	0x00 ~ 0xFE	RW	Overload check interval, 11.2ms/Tick, 0x96 : 1.68s
43	Stop Threshold	1	0x00 ~ 0xFE	RW	Stop Threshold
44	Inposition Margin	1	0x00 ~ 0xFE	RW	Offset Threshold
45	Reserved	1	—	—	Reserved
46	Reserved	1	—	—	Reserved
47	Calibration Difference	1	-128 ~ 127	RW	Servo compensation
48	Status Error	1	0x00 ~ 0x7F	RW	Refer to Pg 39
49	Status Detail	1	0x00 ~ 0x7F	RW	Refer to Pg 39
50	Reserved	1	—	—	Reserved
51	Reserved	2	—	—	Reserved
52	Torque Control	1	MASK : 0x60	RW	Torque enable states (Refer to Pg 28)
53	LED Control	1	0x00 ~ 0x07	RW	0x01:Green, 0x02:Blue, 0x04:Red
54	Voltage	2	0x00 ~ 0xFE	RO	Input voltage Raw Data, 8Bit (Refer to detail in Pg 31)
55	Temperature	2	0x00 ~ 0xFE	RO	Current temp Raw Data, 8Bit (Refer to detail in Pg 31)
56	Current Control Mode	2	0 ~ 1	RO	0 : Position Control, 1 : Turn / Velocity Control
57	Tick	2	0x00 ~ 0xFF	RO	11.2ms/Tick
58	Calibrated Position	2	—	RO	Calibrated current position Raw Data 10Bit(0~1023)
60	Absolute Position	2	—	RO	Uncalibrated absolute position Raw Data
62	Differential Position	2	—	RO	Position change/11.2ms
64	PWM	2	—	RO	Torque Raw Data
66	Reserved	2	—	—	Reserved
68	Absolute Goal Position	2	—	RO	Uncalibrated goal position Raw Data
70	Absolute Desired Trajectory Position	2	—	RO	Current intermediate goal position in trajectory
72	Desired Velocity	1	—	RO	Desired speed based on speed profile Raw Data

Register Detail

NO	Type	Bytes	EEP ADDR	RAM ADDR	RW	Description
1	Model No1	1	0	—	RO	Servo Model Name
2	Model No2	1	1	—		
3	Version1	1	2	—	RO	Firmware Version (※ for DRS-0201, Model No1 is 0x02)
4	Version2	1	3	—		
5	Baud Rate	1	4	—	RW	<ul style="list-style-type: none"> Default Baud Rate is 115,200bps • 0x02 : 666,666bps • 0x03 : 500,000bps • 0x04 : 400,000bps • 0x07 : 250,000bps • 0x09 : 200,000bps • 0x10 : 115,200bps • 0x22 : 57,600bps ※ Baud Rate error within 3%
6	Reserved	1	5	—	—	Reserved
7	ID	1	6	0	RW	<ul style="list-style-type: none"> • Servo ID, Error when same ID exists within the same network. • Range 0 ~ 253 ※ pID up to 254 Servo ID maximum 253
8	ACK Policy	1	7	1	RW	<ul style="list-style-type: none"> Sets ACK packet reply policy when Request packet received • 0 : No reply • 1 : Only reply to Read CMD • 2 : Reply to all Request Packet ※ When CMD is STAT, ACK packe will be sent regardless of r(ACK Policy) ※ When pID(Boradcast pID)is 254 no reply (Exception when CMD is STAT)
9	Alarm LED Policy	1	8	2	RW	<ul style="list-style-type: none"> • Sets Alarm LED policy when error. r(LED Policy) & r(Status Error) TRUE } LED blink • LED blink period set by r(LED Blink Period) When error LED blink } ignore r(LED Control) value • Resolve r(Status Error) Error to make r(LED Control) function normally
10	Torque Policy	1	9	3	RW	<ul style="list-style-type: none"> • r(Servo Policy) & r(Status Error) TRUE } Torque release(Torque Off) • When Torque released, by errorTorque On not possible regardless of value in r(Torque Control) • Servo does not automatically revert to Torque On even after r(Status Error) has been resolved • Enable Toque On using r(Torque Control) after r(Status Error) has been resolved
11	Reserved	1	10	4	—	Reserved
12	Max. Temperature	1	11	5	RW	<ul style="list-style-type: none"> Maximum operational temperature • When r(Temperature) is greater than r(Max. Temperature) r(Status Error) "Exceed Temperature Limit" activated
13	Min. Voltage	1	12	6	RW	<ul style="list-style-type: none"> Minimum operational voltage • When Servo input voltage r(Voltage) is below r(Min. Voltage), r(Status Error) "Exceed Voltage Limit" activated • Voltage = 0,074 X ADC
14	Max. Voltage	1	13	7	RW	<ul style="list-style-type: none"> Maximum operational voltage • When Servo input voltage r(Voltage) is greater than r(Max. Voltage), r(Status Error) "Exceed Voltage Limit" activated • Voltage = 0,074 X ADC

NO	구분	Bytes	EEP ADDR	RAM ADDR	RW	Description
15	Acceleration Ratio	1	14	8	RW	<ul style="list-style-type: none"> Acceleration ratio regarding velocity Profile Ratio of operation time of Motion command (I_JOG, S_JOG), % Acceleration ratio is same as deceleration ratio Maximum r(Acceleration Ratio) value is 50 Ex) When operating time is 100ms and r(Acceleration Ratio) is 20 : Acceleration time is $100 \times 0.2 = 20\text{ms}$ ※ When r(Acceleration Ratio) is 0, speed profile is rectangle ※ When r(Acceleration Ratio) is below 50, velocity profile is triangle
16	Max. Acceleration Time	1	15	9	RW	<ul style="list-style-type: none"> Maximum acceleration time(1 : 11.2ms) When maximum acceleration time r(Max. Acceleration Time) is 254 = 2.844sec ※ When r(Max. Acceleration Time) is 0 velocity profile is rectangle
17	Dead Zone	1	16	10	RW	<ul style="list-style-type: none"> Outside control range Dead Zone only functions within position control
18	Saturator Offset	1	17	11	RW	<ul style="list-style-type: none"> Select Offset at Saturator curve ※ Not applicable in infinite Turn (continuous turn)
19	Saturator Slope	2	18	12	RW	<ul style="list-style-type: none"> Saturator does not work when r(Saturator Slope)=0 Actual Saturator Slope = r(Saturator Slope) / 256 ※ Not applicable infinite Turn Mode (continuous turn)
20	PWM Offset	1	20	14	RW	<ul style="list-style-type: none"> PWM Offset value PWM increases by r(PWM Offset) amount ※ When PWM is at maximum value, Servo at current load outputs maximum Torque and speed ※ When PWM is 0, Servo stopped ※ Maximum PWM value 1023 ※ Not applicable infinite Turn(continuous turn)
21	Min. PWM	1	21	15	RW	<ul style="list-style-type: none"> Minimum PWM = Sets Minimum Torque ※ When PWM is at maximum value, Servo at current load outputs maximum Torque and speed ※ When PWM is 0, Servo stopped ※ Maximum PWM value 1023
22	Max. PWM	2	22	16	RW	<ul style="list-style-type: none"> Maximum PWM = Sets Maximum Torque ※ Smaller this value, Maximum Servo Torque decreases ※ When PWM is at maximum value, Servo at current load outputs maximum Torque and speed ※ When PWM is 0, Servo stopped ※ Maximum PWM value 1023
23	Overload PWM Threshold	2	24	18	RW	<ul style="list-style-type: none"> Sets overload activation point External force divided into 0~1023 steps, Overload error when force > r(Overload PWM Threshold) is exerted for period longer than r(Overload Detection Period) Not activated when This value is > 1023
24	Min. Position	2	26	20	RW	<ul style="list-style-type: none"> Minimum operational angle When requested position angle is less than r(Min. Position), "Exceed Allowed POT Limit" activated, Actual operation is limited to r(Min. Position)
25	Max. Position	2	28	22	RW	<ul style="list-style-type: none"> Maximum operational angle When requested position angle is greater than r(Max. Position), "Exceed Allowed POT Limit" activated, Actual operation is limited to r(Max. Position)

NO	Type	Bytes	EEP ADDR	RAM ADDR	RW	Description
26	Position Kp	2	30	24	RW	Proportional Gain
27	Position Kd	2	32	26	RW	Derivative Gain
28	Position Ki	2	34	28	RW	Integral Gain
29	Position Feedforward 1st Gain	2	36	30	RW	Refer to Pg 35
30	Position Feedforward 2nd Gain	2	38	32	RW	Refer to Pg 35
31	Reserved	2	40	34	–	Reserved
32	Reserved	2	42	36	–	Reserved
33	LED Blink Period	1	44	38	RW	Alarm LED blink period according to policy 11,2ms
34	ADC Fault Check Period	1	45	39	RW	Temp/Voltage error check interval • 1 = 11,2ms • Error activated if Temp/V error lasts longer than the check interval
35	Packet Garbage Check Period	1	46	40	RW	Incomplete packet error check interval • 1 = 11,2ms • Incomplete packet is deleted if it remains longer than the error check interval
36	Stop Detection Period	1	47	41	RW	Time limit to determine if the servo has stopped • 1 = 11,2ms • Servo confirmed Stopped if stoppage lasts past set time limit
37	Overload Detection Period	1	48	42	RW	Overload error check interval
38	Stop Threshold	1	49	43	RW	When position change is less than r(Stop Threshold), Servo seen as having stopped
39	Inposition Margin	1	50	44	RW	Standard value to determine if goal position reached. • if deviation from goal position is less than r(Inposition Margin) recognized as goal position reached
40	Reserved	1	51	45	–	Reserved
41	Reserved	2	52	46	–	Reserved
42	Calibration Difference	1	53	47	RW	• Used to calibrate Neutral point(POS. : 512) • Absolute position = Calibrated position + r(Calibration Difference) • r(Calibration Difference) = Absolute position – Neutral point(512)
43	Status Error	1	–	48	RW	Shows 7 different status Refer to Pg 39
44	Status Detail	1	–	49	RW	Shows 7 different status Refer to Pg 39
45	Reserved	1	–	50	–	Reserved
46	Reserved	1	–	51	–	Reserved
47	Torque Control	1	–	52	RW	• Torque enable states 0x40 : Break On, 0x60 : Torque On 0x00 : Torque Free • When Torque enabled, Mode depends on r(Current Control Mode) before Torque On, ※ r(Current Control Mode) defaults to Position Control(0) when servo powered on ※ Torque On : Operation possible state ※ Break On : Operation command (I_JOG, S_JOG) not possible ※ Torque Free : Similar to Break On, Joints manually movable.

NO	Type	Bytes	EEP ADDR	RAM ADDR	RW	Description
48	LED Control	1	—	53	RW	Servo LED control <ul style="list-style-type: none"> When corresponding Bit value 1 = On, 0 = Off (0x01 : Green, 0x02 : Blue, 0x04 : Red) ※ When alarm LED activated by r(Status Error) and r(Alarm LED Policy), r(Led Control) Write value ignored
49	Voltage	1	—	54	RO	Input Voltage = 0,074 X ADC
50	Temperature	1	—	55	RO	Internal Servo Temperature
51	Current Control Mode	1	—	56	RO	Current time Servo control mode <ul style="list-style-type: none"> L_JOG / S_JOG CMD Packet used to change control mode When Torque On using r(Torque Control), Servo refers to r(Current Control Mode) 0 : Position Control 1 : Turn/Velocity Control(Continuous rotation)
52	Tick	1	—	57	RO	<ul style="list-style-type: none"> Servo operating time, Max setting 2,8672sec 0~255, 1 = 11,2ms
53	Calibrated Position	2	—	56	RO	<ul style="list-style-type: none"> Calibrated position Raw Data Refer to r(Calibration Difference)
54	Absolute Position	2	—	58	RO	<ul style="list-style-type: none"> Absolute position Raw Data Angle = r(Absolute Position) X 0,325
55	Differential Position	2	—	60	RO	<ul style="list-style-type: none"> Shows speed measurement, interval 11,2ms r(Diff Position)1 = 29,09deg/sec
56	PWM	2	—	62	RO	Current Torque, 1023 = Max Torque
57	Reserved	2	—	64	—	Reserved
58	Absolute Goal Position	2	—	66	RO	<ul style="list-style-type: none"> Absolute Goal position Raw Data User selected Goal Position Uncalibrated value
59	Absolute Desired Trajectory Position	2	—	68	RO	<ul style="list-style-type: none"> Current Intermediate goal position based on velocity Profile, Raw Data r(Absolute Desired Trajectory Position) is current goal position
60	Desired Velocity	2	—	70	RO	<ul style="list-style-type: none"> Current intermediate goal speed based on velocity Profile, Raw Data r(Desired Velocity) velocity required at current time.

▶ Acceleration Ratio(RAM Register Address 8)

Acceleration Ratio is controlled by changing the parameter value and any change in the acceleration ratio is applied to the deceleration ratio by exactly the same amount. The default Acceleration Ratio parameter shows a trapezoidal type speed profile.

- ※ Increasing the acceleration ratio will lead to sudden change in speed accompanied by vibration as shows in blue rectangle graph. Decreasing the ratio will show slow increase in speed with smooth movement as in green triangle graph.

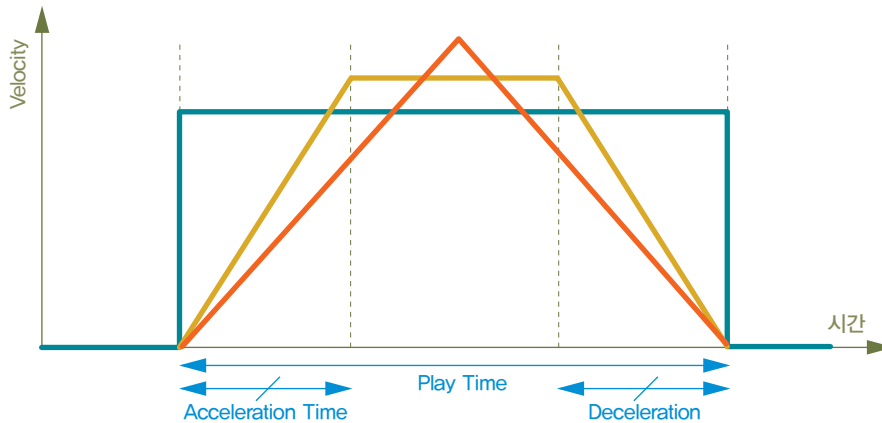

▶ Maximum Acceleration Time(RAM Register Address 9)

Controls maximum acceleration time, 1 is equivalent to 11.2ms.
Maximum acceleration time r(Maximum Acceleration Time) 254 is equivalent to 2.844sec.

- ※ When r(Maximum Acceleration Time) is 0, velocity Profile is rectangle.

▶ Torque Control(RAM Register Address 52)

- Controls Torque enable states
 - 0x40 : Break On
 - 0x60 : Torque On
 - 0x00 : Torque Free
 - When the torque is enabled, it's mode depends on "Current Control Mode". If the servo was on Position Control Mode when Torque ON is enabled, it will remain in that mode.
- ※ r(Current Control Mode) defaults to Position Control(0) when servo is first powered on
 - ※ Control commands will only function when Torque On is enabled (I_JOG, S_JOG)
 - ※ Control commands will not function when Break On is enabled (I_JOG, S_JOG)
 - ※ Joints can be manually manipulated when Torque Free is enabled

▶ LED Control(RAM Address 53)

Controls the LEDs.

- When Bit value below is 1 = On, 0 = Off
- 0x01 : Green

- 0x02 : Blue
- 0x04 : Red

※ When Alarm LED is activated by the r(Status Error) or r(Alarm LED Policy), value in r(LED Control) is ignored.

▶ Voltage(RAM Register Address 54)

Shows the ADC(Analog Digital Conversion) value of the input voltage in raw data. The conversion formula to actual voltage is shown below. Refer to the voltage ADC conversion table in page 49.
Voltage = 0.074 X ADC

▶ Temperature(RAM Register Address 55)

Shows the ADC(Analog Digital Conversion) value of the current temperature in raw data. Refer to temperature ADC conversion table in page 51.

▶ Current Control Mode(RAM Register Address 56)

Shows the current control mode of the servo, I_JOG / S_JOG CMD Packet is used to change the mode.

- When r(Torque Control) is used to change the servo state to Torque On, servo first refers to r(Current Control Mode). For example, default mode of the servo when it is first powered up is "Position Control Mode" and when the servo state is changed to Torque On, mode remains at "Position Control Mode". Servo has to be at Off state to change the control mode to "Turn/Velocity Control Mode". With Torque Off, use I_JOG / S_JOG CMD to switch to "Turn/Velocity Control Mode". After the switch, use r(Torque Control) to turn Torque On and the mode will have switched to "Turn/Velocity Control Mode".
- 0 : Position Control
- 1 : Turn / Velocity Control

※ Turn / Velocity Control : Infinite Turn(Continuous Rotation) Mode.

▶ Tick(RAM Register Address 57)

Shows actual length of the servo tick time. Tick time can be changed from 0 ~ 255, tick time reverts back to 0 after 255. 1 is equivalent to 11.2ms, 255 is equivalent to 2,856sec.

▶ Calibrated Position(RAM Register Address 58)

Shows Calibrated Position in raw data. The relationship between Calibrated Position and Absolute Position is as follows.

- Calibrated Position = Absolute Position – r(Calibration Difference, 47 Address)
- Degree = Position Raw Data X 0.325

► Absolute Position(RAM Register Address 60)

Shows uncalibrated current position in raw data. Relationship between Raw Data and actual degree is as follows.

- Degree = Position Raw Data X 0.325

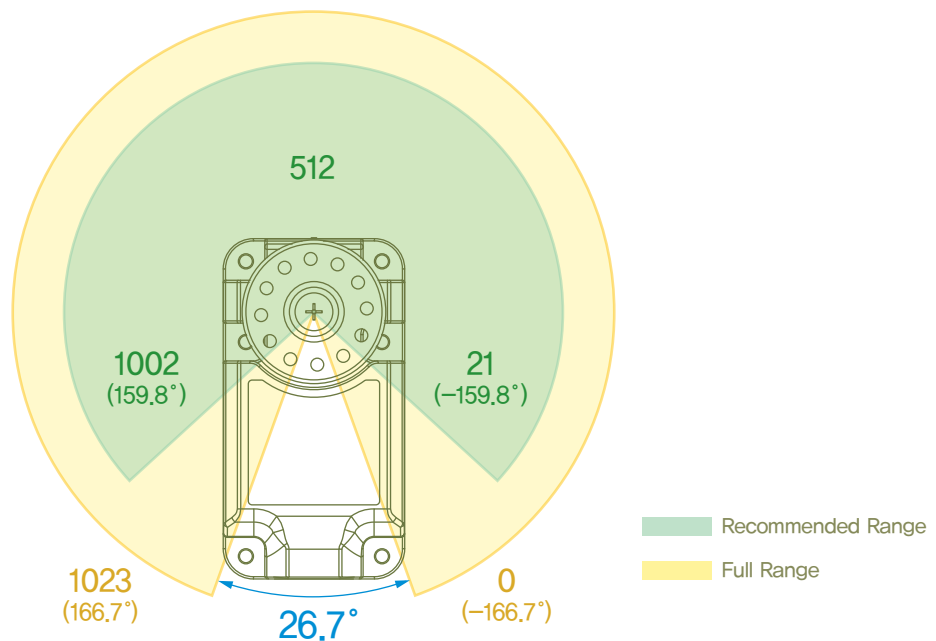

► Diff Position(RAM Register Address 60)

Shows velocity measurement, velocity is measured in 11,2ms intervals.

- ※ r(Diff Position) 1 = 29.09deg/sec

► PWM(RAM Register Address 62)

Shows current Torque in raw data, maximum value is 1023.

► Absolute Goal Position(RAM Register Address 66)

Shows uncalibrated goal position in raw data.

► Absolute Desired Trajectory Position(RAM Register Address 68)

- Uncalibrated current goal position in Raw Data. To arrive at user designated absolute goal position, servo automatically plans out the trajectory to the goal position using the velocity profile. Absolute Desired Trajectory Position is a “current” goal position or intermediate goal position to be reached on the way to final goal position.

Refer to the diagram to see the relationship between Absolute Goal Position and the Absolute Desired Trajectory Position.

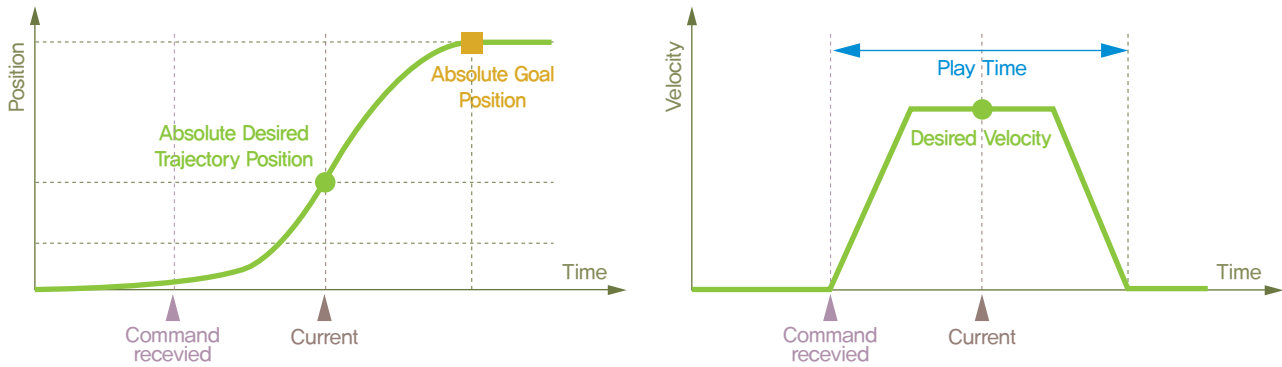

► ACK Policy(RAM Register Address 1)

Sets ACK Packet reply policy when Request Packet is received.

- 0 : No reply to any Request Packet
- 1 : Only reply to Read CMD
- 2 : Reply to all Request Packet

※ When the CMD is “STAT” ACK Packet will be sent regardless of r(ACK Policy).

※ There is no reply when the pID in Request Packet is 254(Broadcast pID) with an exception of “STAT” CMD in which case reply will be sent.

► Alarm LED Policy(RAM Register Address 2)

Sets Alarm LED policy when Error is detected.

- When (r(LED Policy) & r(Status Error)) is TRUE, Alarm LED starts to blink, Alarm LED blink period is set by r(LED Blink Period).
- When (r(LED Policy) & r(Status Error)) is TRUE, Any values written to r(LED Control) will be ignored to prevent confusion with Error state.
- Error status r(Status Error) must be resolved first for r(LED Control) to function properly.

※ 'A&B' : Bit And Operator, 1(True) only when A and B are both (True)

► Torque Policy(RAM Register Address 3)

Sets Torque Off policy when Error is detected.

- When (r(Servo Policy) & r(Status Error)) is TRUE, Torque is released (Torque Off). Under the Error condition, servo will not return to Torque ON state regardless of the value written to r(Torque Control).
- Servo does not automatically revert to Torque On state even after r(Status Error) has been resolved. Enable Torque On using r(Torque Control) after r(Status Error) has been resolved.

※ 'A&B' : Bit And Operator, 1(True) only when A and B are both (True)

▶ Maximum Temperature(RAM Register Address 5)

Maximum operational temperature shown in Raw Data.

- When internal servo temperature r(Temperature) exceeds r(Max Temperature), "Exceeded Temperature Limit" in r(Status Error) becomes active.
- Resulting Alarm LED and Torque status can be changed using r(LED Policy), r(Servo Policy).
- Default value is 0xDF(approximately 85°C). Refer to conversion chart (Pg 51) for actual temperature.

※ 'A&B' : 1(True) only when A and B are both (True)

▶ Minimum Voltage(RAM Register Address 6)

Minimum input voltage shown in Raw Data.

- When servo input voltage r(Voltage) is below r(Min Voltage), "Exceeded Voltage Limit" in r(Status Error) becomes active. Resulting Alarm LED and Torque status can be changed using r(LED Policy), r(Servo Policy).
- Default value is 0x5B(approximately 6.74V). Refer to conversion chart (Pg 49) for actual voltage.

▶ Maximum Voltage(RAM Register Address 7)

Maximum input voltage shown in Raw Data.

- When servo input voltage r(Voltage) exceeds r(Max Voltage), "Exceeded Voltage Limit" in r(Status Error) becomes active. Resulting Alarm LED and Torque status can be changed using r(LED Policy), r(Servo Policy).
- Default value is 0x89(approximately 10.14V). Refer to conversion chart (Pg 49) for actual voltage.

▶ Overload PWM Threshold(RAM Register Address 18)

Sets overload activation point. The overload point from external force can be set from 0~1023.

- Overload activates when external force is greater than r(Overload PWM Threshold).
- Overload does not activate when the given value is greater than 1023

▶ Minimum Position(RAM Register Address 20)

Minimum operational angle in Raw Data.

- When requested position angle is less than r(Min Position), "Exceed Allowed POT Limit" in r(Min Position) becomes active and the operation is limited to r(Min Position).
- Default value is 0x15(approximately -159.8°). Refer to conversion chart in (Pg 53) for actual angle.

► **Maximum Position(RAM Register Address 22)**

Maximum operational angle in Raw Data.

- When requested position angle is greater than r(Max Position), "Exceed Allowed POT Limit" in r(Max Position) becomes active and the operation is limited to r(Max Position).
- Default value is 0x3EA(approximately 159.8 °). Refer to conversion chart in (Pg 53) for actual angle.

► **Position Kp(RAM Register Address 24)**

Shows the Proportional Gain. Increasing the Position Kp increases, the response time but over response (vibration, overshoot) will result if the increase is too large.

► **Position Kd(RAM Register Address 26)**

Shows the Derivative Gain. Increasing the Position Kd will suppress the over response (vibration, overshoot) from Position Kp but instability may result if the increase is too large.

► **Position Ki(RAM Register Address 28)**

Shows the Intergral Gain. Applied to correct small offset in Steady State. May result in response lag if the increase is too large.

► **Position Feedforward Kd(RAM Register Address 30)**

Shows Position Feedforward 1st Gain. Applied to increase Servo response time.

► **Position Feedforward Kdd(RAM Register Address 32)**

Shows Position Feedforward 2nd Gain. applied to increase Servo response time.

► **LED Blink Period(RAM Register Address 38)**

Shows the Alarm LED blink period set by the LED Policy when error occurs. 1 is equivalent to 11.2ms. Default value is 0x2D(Approximately 504ms).

► **ADC Fault Check Period(RAM Register Address 39)**

Temperature / Input voltage error check interval, 1 is equivalent to 11.2ms. Error activated if the Temperature / Input voltage error lasts longer than the check interval. Default value is 0x2D(Approximately 504ms).

► **Packet Garbage Check Period(RAM Register Address 40)**

Incomplete Packet error check interval, 1 is equivalent to 11.2ms. Incomplete Packet is deleted if it remains longer than the check interval. Default value is 0x12(Approximately 201ms)

► Stop Detection Period(RAM Register Address 41)

Set time limit by which the servo stoppage is measured to determine if it has stopped. 1 is equivalent to 11,ms. If the servo stoppage lasts beyond the time limit, it is determined to be stopped.
Default value is 0x1B (Approximately 302ms)

► Overload Detection Period(RAM Register Address 42)

Set time limit by which the servo overload is measured to determine if the overload has occurred. If the overload period lasts beyond the time limit, it is determined to be overloaded.
Default value is 0x96 (Approximately 1.68s)

► Stop Threshold(RAM Register Address 43)

The servo is seen as not moving (stopped) when the position movement of the servo is less than the r(Stop Threshold). The servo is determined to be stopped if the stoppage lasts longer than the r(Stop Detection Period).

► Inposition Margin(RAM Register Address 44)

Standard value to determine if the goal position has been reached.
Goal position is judged to have been reached if the deviation is less than r(Inposition Margin).

► Saturator Offset, Saturator Slope(RAM Register Address 11, 12)

Saturation Offset and Saturation Slope work in similar manner to the PWM. However, by controlling the limit per given section, accurate Saturator can be designed to provide flexible and elastic response to the external force. The graph below shows the PWM with several settings. The thick grey line show the PWM without the Saturator Offset and Slope settings. The red line shows the actual PWM output with the Saturator Offset & Slope set. The blue dotted line shows the boundary of the force restrained by the Saturator. The restrain by the Saturator on PWM value increases when near the goal position and decreases when further away from the goal position. The effect on PWM is similar to having a spring installed near the goal position, resulting in low strength near the goal position and strength increasing with distance. Assuming the servo is stopped at the goal position, Saturator allows flexible response to external force, and provides assistance when trying to hold delicate object.

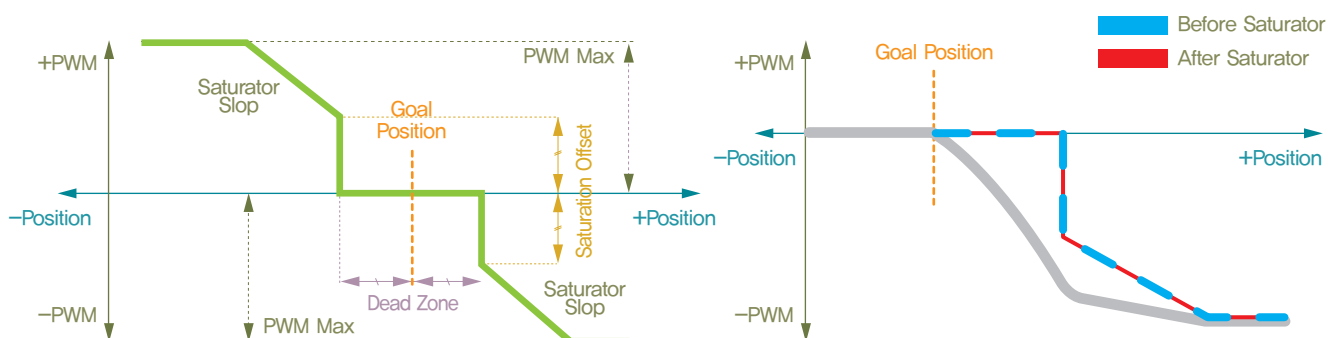

► PWM Offset(RAM Address 14)

When the 0 point of the PWM is moved, PWM will increase output by the amount of the Offset. This output could be used to act as a compensator in a system where load is on one side (Ex: Gravity). By moving the 0 point, constant force directed towards 0 point can be applied.

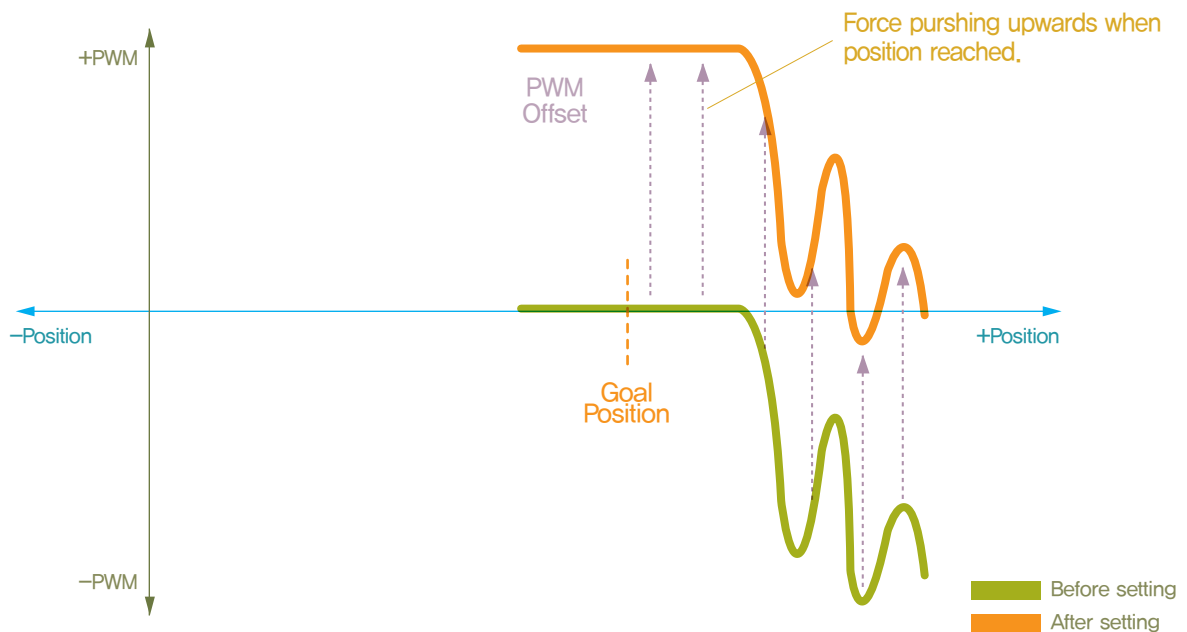

► Minimum PWM(RAM Register Address 15)

PWM output value does not fall below the r(Min. PWM). Minimum PWM is used when there is jerky movement due to tight fitting or friction in the servo application system but assigning Minimum PWM that is too large may lead to unstable system.

► Maximum PWM(RAM Register Address 16)

PWM output value does not exceed r(Max. PWM). Battery life could be increased by limiting the Maximum PWM but it will also decrease the maximum servo torque.

► Relationship between Saturator & PWM

PWM results in servo output. As seen in the graph below, there are several parameters controlling the servo output. These parameters can be manipulated to build optimum servo system. To see the characteristics of each parameter, refer to the detailed explanation section in the manual.

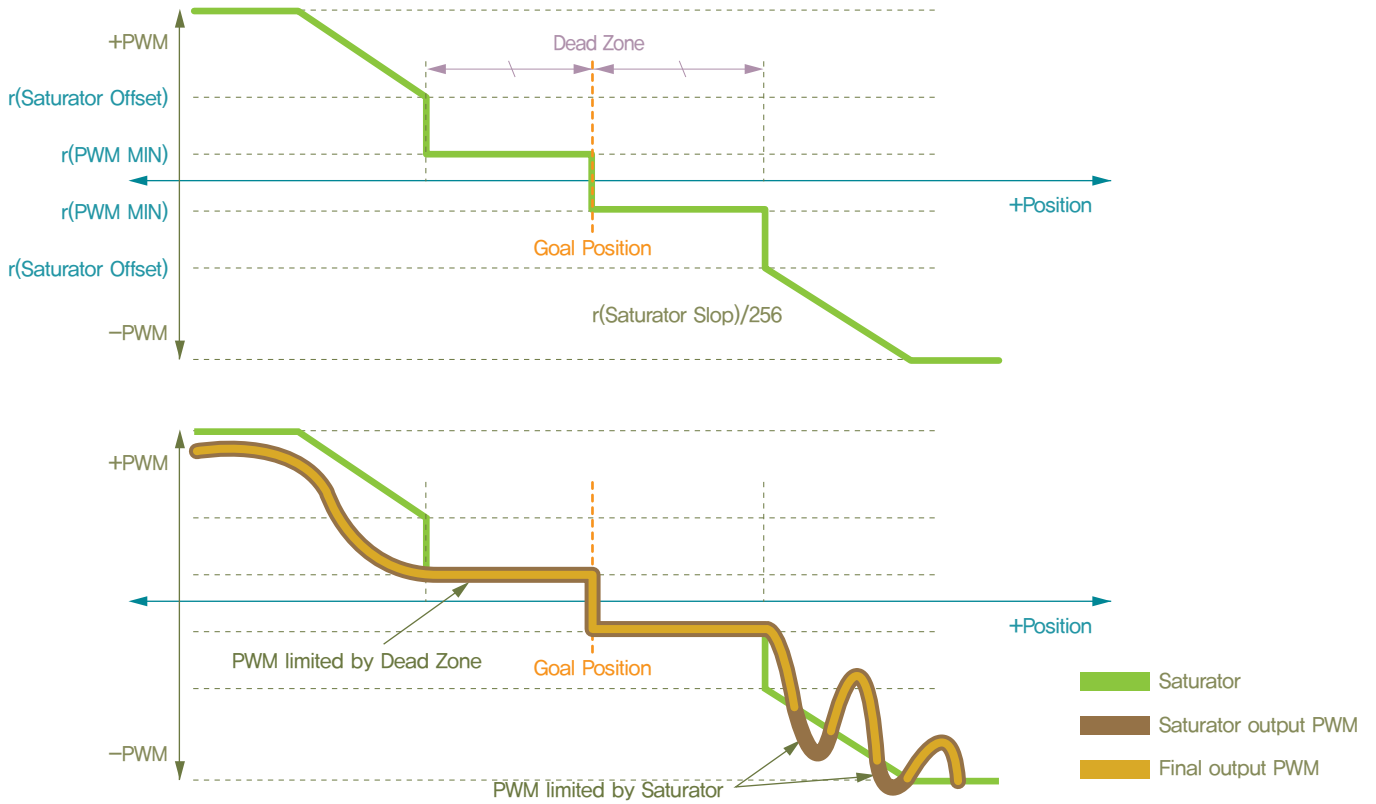

► Calibration Difference(RAM Register Address 47)

Used to calibrate newtral point(standard). Used to make adjustments to compensate for assembly variations when servos are used to build a system. Calibrated Difference is calculated by following formula

- $\text{Calibrated Position} = \text{Absolute Position} - \text{Calibration Difference}$

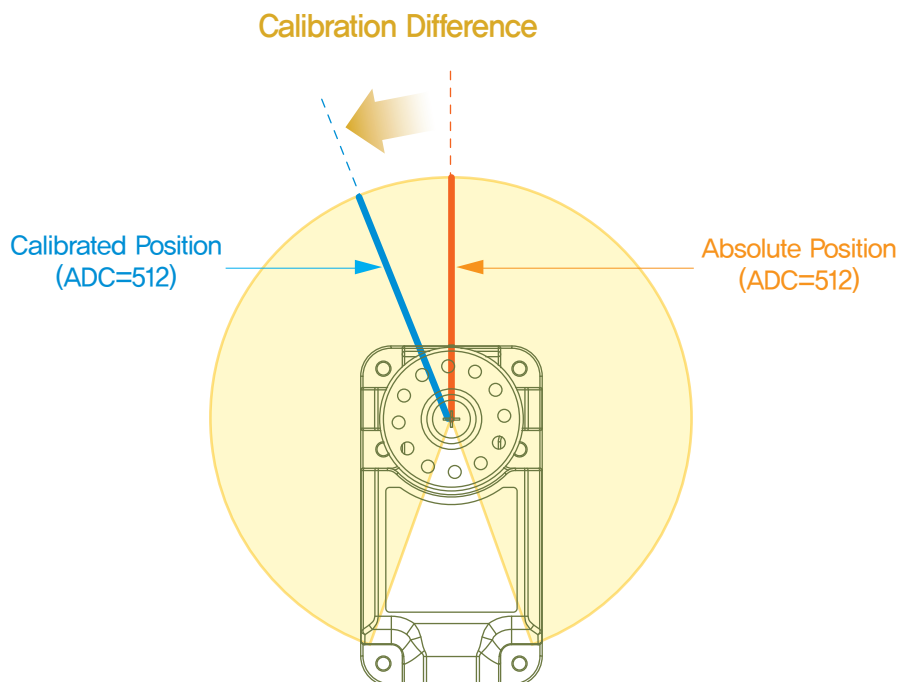

► Status Error, Status Details(RAM Register Address 48, 49)

Status																	
REG (Status Error)				REG (Status Error)													
Bits	7	6	5	4	3	2	1	0	Bits	7	6	5	4	3	2	1	0
Bits	Value	Comment		Bits	Value	Comment											
0	0X01	Exceed Input Voltage limit		0	0X01	Moving flag											
1	0X02	Exceed allowed POT limit		1	0X02	Inposition flag											
2	0X04	Exceed Temperature limit		2	0X04	Checksum Error											
3	0X08	Invalid Packet		3	0X08	Unknown Command											
4	0X10	Overload detected		4	0X10	Exceed REG range											
5	0X20	Driver fault detected		5	0X20	Garbage detected											
6	0X40	EEP REG distorted		6	0X40	MOTOR_ON flag											
7	0X80	reserved		7	0X80	reserved											

- ※ LED Policy, Servo Policy : Same as above
- ※ LED Policy : When Check bit error occurs, LED(RED) blinks consistently
- ※ Servo Policy : When Check bit error occurs, Torque is released to Freerun state

- ※ When Invalid Packet occurs, detailed information is record in Status Detail Register
- ※ Moving/Inposition/MOTOR_ON flag are Read only.
- ※ MOTOR_ON : Torque ON

- Yellow lines above points to error detail when Status Error shows Invalid Packet(0x08).
- Invalid Packet can be divided into 5 different causes, 4 shows in the Status Detail and other.
- Portions of Status Detail are Read only but can be Written to by the Protocol.
Read only values are just ignored not actually Written to.

5. Command Set

To control the Servo, CMD is sent to the servo from the Controller in Binary format. Our servos are controlled by 9 different CMDs. Once the Servo receives Request Packet with included CMD, Servo performs requested operation and returns the result to the Controller by ACK Packet.

5-1. [To Servo Module] – Request Packet

Type	CMD	Explanation
EEP_WRITE	0x01	• Write Length number of values to EEP Register Address
EEP_READ	0x02	• Request Length number of values from EEP Register Address • May not reply, depending on r(ACK Policy)
RAM_WRITE	0x03	• Write Length number of values to RAM Register Address
RAM_READ	0x04	• Request Length number of values from RAM Register Address • May not reply, depending on r(ACK Policy)
I_JOG	0x05	• Able to send JOG command to maximum 43 servos. • I_JOG can set the operation timing of individual Servo • I_JOG Refer to Pg 48 for details
S_JOG	0x06	• Able to send JOG command to maximum 53 servos. • S_JOG All the Servos operate simultaneously at same time • S_JOG Refer to Pg 48 for details
STAT	0x07	• Status Error, Status Detail request • Always send reply regardless of r(ACK Policy)
ROLLBACK	0x08	• Change all EEP Registers to Factory Default value • Apply changes after power reset • ID, and Baud Rate maybe exempt from Factory Default depending on ID Skip and Baud Skip setting.
REBOOT	0x09	• Request Reboot

5-2. [To Controller(ACK)] – ACK Packet

Type	CMD	Meaning
EEP_WRITE	0x41	• CMD(0x01) Reply Packet • Default is no reply, Reply possible by changing r(ACK Policy) setting
EEP_READ	0x42	• Reply with “n” number of values from EEP Register Address • May not reply depending on r(ACK Policy) setting

Type	CMD	Explanation
RAM_WRITE	0x43	<ul style="list-style-type: none"> • CMD(0x03) Reply Packet • Default is no reply, reply possible by changing r(ACK Policy) setting
RAM_READ	0x44	<ul style="list-style-type: none"> • CMD(0x04) Reply Packet • May not reply depending on r(ACK Policy) setting.
I_JOG	0x45	<ul style="list-style-type: none"> • CMD(0x05) Reply Packet • Default is no reply, reply possible by changing r(ACK Policy) setting
S_JOG	0x46	<ul style="list-style-type: none"> • CMD(0x06) Reply Packet • Default is no reply, reply possible by changing r(ACK Policy) setting
STAT	0x47	<ul style="list-style-type: none"> • r(Status Error, Status Detail) Reply, Always Reply regardless of r(Ack Policy)
ROLLBACK	0x48	<ul style="list-style-type: none"> • CMD(0x08) Reply Packet • Default is no reply, reply possible by changing r(ACK Policy) setting
REBOOT	0x49	<ul style="list-style-type: none"> • CMD(0x09) Reply Packet • Default is no reply, reply possible by changing r(ACK Policy) setting

※ ACK option changeable by using r(ACK Policy)

※ ACK Packet CMD is Request Packet CMD + 0x40

※ Last 2 Bytes of the ACK Packet includes r(Status Error, Status Detail)

5-3. CMD(Command) Detailed Explanation

CMD	Explanation
EEP_READ	<ul style="list-style-type: none"> • Request to read Length # of values from EEG Register Address • Optional Data length is 2
RAM_READ	<ul style="list-style-type: none"> • Request to read Length # of values from RAM Register Address • Optional Data length is 2
EEP_WRITE	<ul style="list-style-type: none"> • Request to write Length # of values to EEG Register Address • Optional Data length is Address & Length 1 Byte each + Length Byte
RAM_WRITE	<ul style="list-style-type: none"> • Request to write Length # of values to RAM Register Address • Optional Data length is Address & Length 1 Byte each + Length Byte
I_JOG	<ul style="list-style-type: none"> • Send instructions to multiple servos simultaneously, able to set position/time to each servo independently. Able to set goal position time arrival time to each independently • I_Jog requires 5Bytes of data for each servo. Optional Data length of 50Bytes required if sending instructions to 10 servos simultaneously
S_JOG	<ul style="list-style-type: none"> • Able to send instructions to multiple servos simultaneously, All servos have same operational timing. All servos arrive at goal position at same time. • S_Jog requires 1byte for Playtime and 4Bytes for each servo. Optional Data length of 41Bytes required if sending instructions to 10 servos simultaneously
STAT	<ul style="list-style-type: none"> • Request Servo Status r(Status Error, Status Detail) • STAT Packet always receive reply
ROLLBACK	<ul style="list-style-type: none"> • Change all values in EEPROM_Register to Factory default value. • ID and Baud Rate maybe exempted from Factory Default by using ID Skip, Baud Skip Byte
REBOOT	<ul style="list-style-type: none"> • Reboot Servo

6. Command Examples

5-1. EEP_READ

Request 4 Bytes of information from EEP Register 0x1E Address of Servo ID(253). 4 Bytes from EEP Register 0x1E Address are e(Position Kp)and e(Position Kd).

EEP_READ	Header		Packet Size	pID	CMD
	0	1	2	3	4
	0xFF	0xFF	9	Servo ID	0x02
Example1	0xFF	0xFF	0x09(9)	0xFD	0x02

EEP_READ	Check Sum1	Check Sum2	Data	
	5	6	7	8
	(Refer to Checksum formula)		Data[0] (Address)	Data[1] (Length)
Example1	0xEC	0x12	0x1E	0x04

EEP READ

Request to read Length # of values from EEP Register Address. Data length is 2Bytes
(Address 1Byte + Length 1Byte)

Packet Size	pID	EEP READ CMD
7(Standad Size)+2(Data length)	Servo ID 0xFD(253)	0x02 (Refer to Pg 40)

CHECKSUM1 Formula

$$\text{Checksum1} = (\text{PacketSize} \wedge \text{pID} \wedge \text{CMD} \wedge \text{Data}[0] \wedge \text{Data}[1]) \& 0xFE$$

DATA[0]

Refers to starting address of EEP Register being Read, 0x1E(30) in the example is starting address of Position Kp.

DATA[1]

Data[1], Refers to number of Bytes to be READ from the starting address, 0x04 in the example means 4Bytes will be read. In other words, 4Bytes from Position Kp starting address will be read, Position Kp(2Bytes variable)and Position Kd(2Bytes variable) will be read.

ACK Packet

EEP_READ	Header		Packet Size	pID	CMD	Check Sum1	Check Sum2
	0	1	2	3	4	5	6
ACK of Example1	0xFF	0xFF	0x0F	0xFD	0x42	0x4C	0xB2
Data							
7	8	9	10	11	12	13	14
Data[0] (Address)	Data[1] (Length)	Data[2]	Data[3]	Data[4]	Data[5]	Data[4] (Status Error)	Data[5] (Status Detail)
0x1E	0x04	0xB8	0x01	0x40	0x1F	0x00	0x00

- CMD : Request Packet CMD(0x02) + 0x40, Reply with 0x42
- e(Position Kp) : 440(0x1B8)
- Position Kd : 8000(0x1F40)
- Last 2Bytes of all ACK Packet contain Status Error(1Byte) and Status Detail (1Byte)

6-2. EEP_WRITE

ID(253), e(Position Kp) / Kd(Address 0x1E=30, 4Bytes Register) Kp = 200(0x00C8),
Kd = 1000(0x03E8) Write

EEP_WRITE	Header		Packet Size	pID	CMD	Check Sum1	Check Sum2
	0	1	2	3	4	5	6
	0xFF	0xFF	7+(2+Length)	Servo ID	0x01	(Refer to Checksum Formula)	
Example1	0xFF	0xFF	0x0D(13)	0xFD	0x01	0XC8	0X36
Data							
7	8	9	11	12	13		
Data[0] (Address)	Data[1] (Length)	Data[2]	Data[3]	Data[4]	Data[5]		
0x1E	0x04	0XC8	0X00	0XE8	0X03		

Data[2] ~ Data[5]

Data[2], Data[3] will be changed to e(Position Kp) and Data[4], Data[5] will be changed to e(Position Kp). You must input Byte in reverse order by Little Endian rule.

※ Refer to Pages 23 for Little Endian.

EEP Register

To apply changed EEP Register value, Servo has to be reboot first.

6-3. RAM_WRITE

Example 1

ID(253), r(LED Control), Address(0x35(53)) Request Green LED On.

Example 2

ID(253), r(Status Error, Status Detail), Request to Clear Address(0x30(48)) to "0".

Example 3

ID(253), r(Torque Control), Request to write 0x60 to Address(0x34(52)) for Torque On.

※ Make sure to have Torque On before (I_JOG, S_JOG) command to avoid error.

RAM_WRITE	Header		Packet Size	pID	CMD	Check Sum1	Check Sum2
	0	1	2	3	4	5	6
	0xFF	0xFF	7+(2+Length)	Servo ID	0x03	(Refer to Checksum Formula)	
Example1	0xFF	0xFF	0x0A(10)	0xFD	0x03	0xC0	0x3E
Example2	0xFF	0xFF	0x0B(11)	0xFD	0x03	0xC6	0x38
Example3	0xFF	0xFF	0x0A(10)	0xFD	0x03	0xA0	0x5E
Optional Data							
	7	8	9	10			
	Data[0] (Address)	Data[1] (Length)	Data[2]	Data[3]			
	0x35	0x01	0x01	–			
	0x30	0x02	0x00	0x00			
	0x34	0x01	0x60	–			

6-4. RAM_READ

Example 1

ID(253), Read 1 Byte from Address 0x35(53), Addressed Register is r(LED Control)

RAM_READ ACK

Reply to RAM_READ(CMD 0x04)with Packet, reply CMD is 0x44, last 2Bytes of All ACK Packet contain r(Status Error) and r(Status Detail). ACK Packet reply option can be changed by r(ACK Policy)

Data[2]

0x01 is r(LED Control) value, it means Green LED is on.

Data[3]

Data[3] is Status Error: No Error, Data[4] 0x42 means Torque On and Inposition, Arrived at goal position.

RAM_READ	Header		Packet Size	pID	CMD	Check Sum1	Check Sum2
	0	1	2	3	4	5	6
	0xFF	0xFF	7+(2+Length)	Servo ID	0x03	(Refer to Checksum Formula)	
Example1	0xFF	0xFF	0x09(9)	0xFD	0x04	0xC4	0x3A
RAM_READ ACK	0xFF	0xFF	0x0C(12)	0xFD	0x44	0xC2	0x3C
Optional Data							
7	8	9	10	11			
Data[0] (Address)	Data[1] (Length)	Data[2]	Data[3]	Data[4]			
0x35	0x01	–	–	–			
0x35	0x01	0x01	0x00	0x42			

6–5. I_JOG

Example 1

ID(253), Position Control, Position Goal 512, Green LED On, Operating Time(60 : 672ms)

Example 2

ID(253), Continuous Rotation, Goal Speed 320, Blue LED On, Operating Time(60 : 672ms)

I_JOG	Header		Packet Size	pID	CMD	Check Sum1	Check Sum2
	0	1	2	3	4	5	6
	0xFF	0xFF	7+(5×I_JOG)	Servo ID	0x05	(Refer to Checksum Formula)	
Example1	0xFF	0xFF	0x0C(12)	0xFD	0x05	0x32	0xCC
Example2	0xFF	0xFF	0x0C(12)	0xFD	0x05	0x7E	0x80
Optional Data							
7	8	9	10	11			
I_JOG_S(0)							
JOG(LSB)	JOG(MSB)	SET	ID	playtime			
0x00	0x02	0x04	0xFD	0x3C			
40	0x01	0x0A	0x0A	0x3C			

- Refer to Packet structure below for explanation of each Bit in I_JOG
- Able to use Structure as below for convenience
- LSB(Least Significant Bit) first for Bit value
- Example1 SET(0x04) is Position Control, Green LED On

```
typedef struct
{
    int iJogData : 15;
    unsigned int uiReserved1 : 1;

    unsigned int uiStop : 1;
    unsigned int uiMode : 1; //0 : Position Control
    unsigned int uiLED : 3; //Green, Blue, Red
    unsigned int uiJogInvalid : 1;
    unsigned int uiReserved2 : 2;

    unsigned int uclD : 8;

    unsigned char ucJogTime_ms;
} IJOG_TAG
```

※ Bit Variable size or bit field may vary depending on the compiler or compiler setting,
The above example uses 16 bit variable. The structure byte alignment of the process may vary as well. The above example uses 1byte alignment as standard.

6-6. S_JOG

Example 1

ID(253), Position Control, Goal Position 512, Red LED On, Operating Time(60 : 672ms)

Example 2

ID(253), Continuous Rotation, Goal Speed 704, Blue LED On, Operating Time(60 : 672ms)

S_JOG	Header		Packet Size	pID	CMD	Check Sum1	Check Sum2
	0	1	2	3	4	5	6
	0xFF	0xFF	7+(5Xl_JOG #)	Servo ID	0x06	(Refer to Checksum Formula)	
Example1	0xFF	0xFF	0x0C(12)	0xFD	0x06	0x30	0xCE
Example2	0xFF	0xFF	0x0C(12)	0xFD	0x06	0xFE	0x00
Optional Data							
7	8	9	10	11			
PLAY TIME	S_JOG_S(0)						
	JOG(LSB)	JOG(MSB)	SET	ID			
0x3C(60)	0x00	0x02	0x04	0xFD			
0x3C(60)	40	0x01	0x0A	0x0A			

- Refer to Packet structure below for explanation of each Bit in S_JOG
- Able to use Structure as below for convenience
- LSB(Least Significant Bit) first for Bit value
- Example1 SET(0x04) is Position Control, Green LED On

```

typedef struct
{
    int          iJogData          : 15;
    unsigned int uiReserved1      : 1;

    unsigned int uiStop           : 1;
    unsigned int uiMode           : 1; //1 : Speed Control
    unsigned int uiLED            : 3; //Green, Blue, Red
    unsigned int uiJogInvalid     : 1;
    unsigned int uiReserved2     : 2;

    unsigned int uclD             : 8;
} SJOG_TAG

```

※ Bit Variable size or bit field may vary depending on the compiler or compiler setting,
The above example uses 16 bit variable. The structure byte alignment of the process may
vary as well. The above example uses 1byte alignment as standard.

► I_JOG, S_JOG Packet Structure

I_JOG_TAG				S_JOG_TAG			
Type	Information		Comments	Type	Information		Comments
	Bytes	Bits			Bytes	Bits	
JOG	2	0	Case) JOG	JOG	2	0	Case) JOG
		1	Desired Goal POS			1	Desired Goal POS
		2	(Calibration applied)			2	(Calibration applied)
		3	Case) Infinite turn			3	Case) Infinite turn
		4	Desired PWM			4	Desired PWM
		5	※ Infinite turn Sign :			5	※ Infinite turn Sign :
		6	0X4000 MEMS Negative			6	0X4000 MEMS Negative
		7				7	
		8				8	
		9				9	
		10				10	
		11				11	
		12				12	
		13				13	
		14	Sig@Infinite turn			14	Sig@Infinite turn
		15	Reserved=0			15	Reserved=0
SET	1	0	Stop flag	SET	1	0	Stop flag
		1	MODE			1	MODE
		2	LED GREEN			2	LED GREEN
		3	LED BLUE			3	LED BLUE
		4	LED RED			4	LED RED
		5	JOG Invalid(No Action)			5	JOG Invalid(No Action)
		6	Reserved=0			6	Reserved=0
		7	Reserved=0			7	Reserved=0
ID	1	Valid Range : 0~0XFE	ID	1	Valid Range : 0~0XFE		
Playtime	1	Valid Range : 0~0XFE					

MODE	Comments
0	Position Control JOG
1	Infinite turn (Continuous Rotation)

6-7. STAT

ID(253) Request Status

ACK Packet Data[0] refers to Status Error and means no Error

Data[1] refers to Status Detail 0x40 Torque On

※ Refer to Page 39 for detailed information on Status Error and Status Detail.

STAT	Header		Packet Size	pID	CMD	Check Sum1	Check Sum2
	0	1	2	3	4	5	6
	0xFF	0xFF	7	Servo ID	0x07	(Refer to Pg 20)	
Example2	0xFF	0xFF	0x07	0xFD	0x07	0xFC	0x02
STAT ACK	0xFF	0xFF	0x09	0xFD	0x47	0xF2	0x0C
Optional Data							
7	8						
Data[0]	Data[1]						
0x00	0x40						
0x00	0x40						

6-8. ROLLBACK

ID(253) ROLLBACK(Factory Default), ID and Baud Rate excepted

ROLLBACK ACK

When r(ACK Policy) is set to "2" meaning "Always Reply" Send ACK Packet

ROLLBACK	Header		Packet Size	pID	CMD	Check Sum1	Check Sum2
	0	1	2	3	4	5	6
	0xFF	0xFF	9	Servo ID	0x08	(Refer to Pg 20)	
Example1	0xFF	0xFF	0x09	0xFD	0x08	0xFC	0x02
ROLLBACK ACK	0xFF	0xFF	0x09	0xFD	0x48	0xFC	0x02
Optional Data							
7	8						
Data[0]	Data[1]						
ID Skip	Band Skip						
1	1						
00	0x40						

6-9. REBOOT

ID(254) Reboot

REBOOT ACK

When r(ACK Policy) is set to "2" meaning "Always Reply" Send ACK Packet

REBOOT	Header		Packet Size	pID	CMD	Check Sum1	Check Sum2
	0	1					
	0xFF	0xFF	7	Servo ID	0x09	(Refer to Pg 20)	
Example1	0xFF	0xFF	0x07	0xFD	0x09	0xF2	0x0C
REBOOT ACK	0xFF	0xFF	0x09	0xFD	0x49	0xBC	0x42
Optional Data							
7	8						
Data[0]	Data[1]						
-	-						
0x00	0x00						

Reference

2.00mm (0.079") PITCH CONNECTOR



Wire-to-Board
Wafer

YW200 Series

DIP

Straight

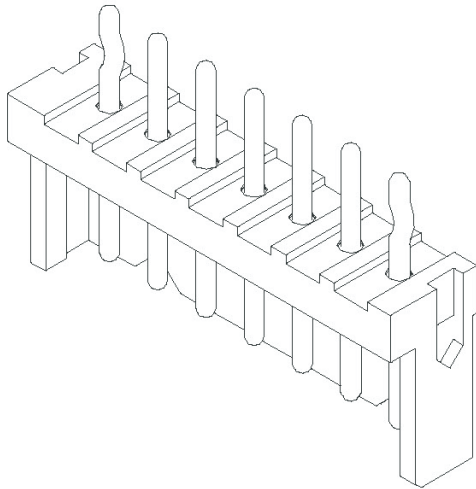

Material

I/NO	DESCRIPTION	TITLE	MATERIAL
1	WAFER	YW200	PA66, UL 94V Grade
2	PIN		Brass, Tin plated

Available Pin

PARTS NO.	A	B	C
YW200-02	5.9	5.1	2.0
YW200-03	7.9	7.1	4.0
YW200-04	9.9	9.1	6.0
YW200-05	11.9	11.1	8.0
YW200-06	13.9	13.1	10.0
YW200-07	15.9	15.1	12.0
YW200-08	17.9	17.1	14.0
YW200-09	19.9	19.1	16.0
YW200-10	21.9	21.1	18.0
YW200-11	23.9	23.1	20.0
YW200-12	25.9	25.1	22.0
YW200-13	27.9	27.1	24.0
YW200-14	29.9	29.1	26.0
YW200-15	31.9	31.1	28.0

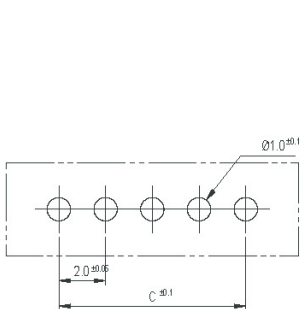
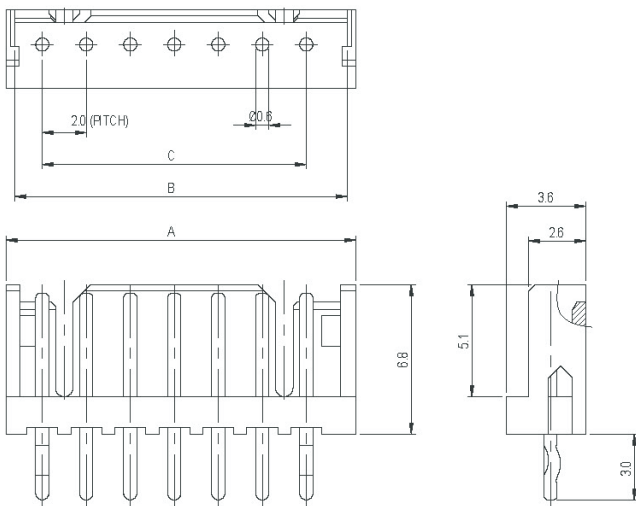

PCB LAYOUT

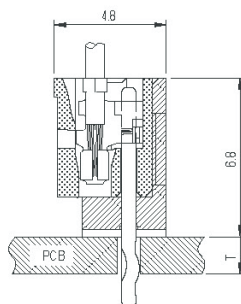

PCB ASS'Y

Specification

ITEM	SPEC
Voltage Rating	AC/DC 125V
Current Rating	AC/DC 3A
Operating Temperature	-25°C~+85°C
Contact Resistance	30mΩ MAX
Withstanding Voltage	AC1000V/1min
Insulation Resistance	1000MΩ MIN
Applicable Wire	-
Applicable P.C.B	1.2~1.6mm
Applicable FPC/FFC	-
Solder Height	-
Crimp Tensile Strength	-
UL FILE NO	E108706

2.00mm (0.079") PITCH CONNECTOR

Wire-to-Board
Housing

YH200 Series

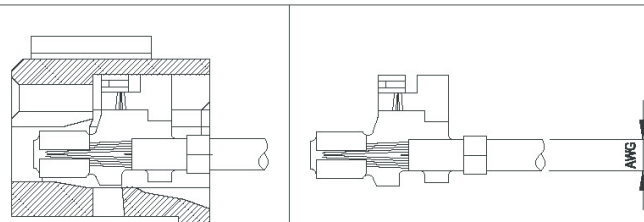
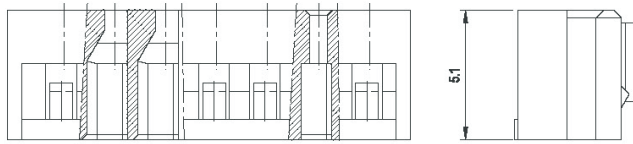
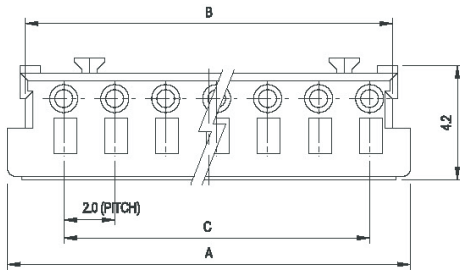
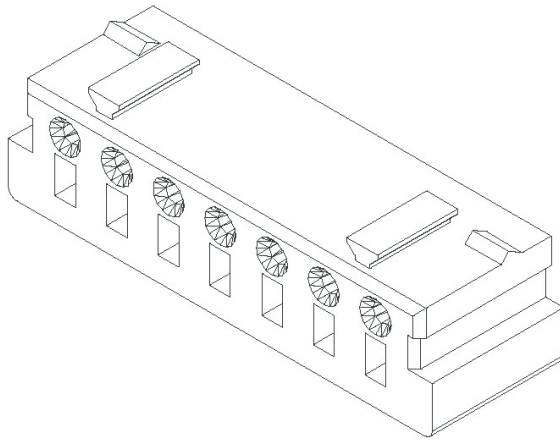

TERMINAL ASSEMBLY DRAWING

AWG: #22-#28

Material

I/NO	DESCRIPTION	TITLE	MATERIAL
1	HOUSING	YH200	PA66, UL 94V Grade

Available Pin

PARTS NO.	A	B	C
YH200-02	5.8	4.4	2.0
YH200-03	7.8	6.4	4.0
YH200-04	9.8	8.4	6.0
YH200-05	11.8	10.4	8.0
YH200-06	13.8	12.4	10.0
YH200-07	15.8	14.4	12.0
YH200-08	17.8	16.4	14.0
YH200-09	19.8	18.4	16.0
YH200-10	21.8	20.4	18.0
YH200-11	23.8	22.4	20.0
YH200-12	25.8	24.4	22.0
YH200-13	27.8	26.4	24.0
YH200-14	29.8	28.4	26.0
YH200-15	31.8	30.4	28.0

Specification

ITEM	SPEC
Voltage Rating	AC/DC 125V
Current Rating	AC/DC 3A
Operating Temperature	-25°C~+85°C
Contact Resistance	30mΩ MAX
Withstanding Voltage	AC1000V/1min
Insulation Resistance	1000MΩ MIN
Applicable Wire	AWG #24-#28
Applicable P.C.B	-
Applicable FPC/FFC	-
Solder Height	-
Crimp Tensile Strength	-
UL FILE NO	E108706

Application Terminal : YT200 (119 page)

ADC Voltage Conversion Chart

ADC		VIN
Decimal	HEX	
0	0	0,000
1	1	0,074
2	2	0,148
3	3	0,222
4	4	0,296
5	5	0,370
6	6	0,444
7	7	0,519
8	8	0,593
9	9	0,667
10	A	0,741
11	B	0,815
12	C	0,889
13	D	0,963
14	E	1,037
15	F	1,111
16	10	1,185
17	11	1,259
18	12	1,333
19	13	1,407
20	14	1,481
21	15	1,556
22	16	1,630
23	17	1,704
24	18	1,778
25	19	1,852
26	1A	1,926
27	1B	2,000
28	1C	2,074
29	1D	2,148
30	1E	2,222
31	1F	2,296
32	20	2,370
33	21	2,444
34	22	2,519
35	23	2,593
36	24	2,667
37	25	2,741
38	26	2,815
39	27	2,889
40	28	2,963
41	29	3,037
42	2A	3,111
43	2B	3,185
44	2C	3,259
45	2D	3,333
46	2E	3,407
47	2F	3,481
48	30	3,556
49	31	3,630
50	32	3,704
51	33	3,778
52	34	3,852
53	35	3,926
54	36	4,000
55	37	4,074
56	38	4,148
57	39	4,222
58	3A	4,296
59	3B	4,370
60	3C	4,444
61	3D	4,519
62	3E	4,593
63	3F	4,667

ADC		VIN
Decimal	HEX	
64	40	4,741
65	41	4,815
66	42	4,889
67	43	4,963
68	44	5,037
69	45	5,111
70	46	5,185
71	47	5,259
72	48	5,333
73	49	5,407
74	4A	5,481
75	4B	5,556
76	4C	5,630
77	4D	5,704
78	4E	5,778
79	4F	5,852
80	50	5,926
81	51	6,000
82	52	6,074
83	53	6,148
84	54	6,222
85	55	6,296
86	56	6,370
87	57	6,444
88	58	6,519
89	59	6,593
90	5A	6,667
91	5B	6,741
92	5C	6,815
93	5D	6,889
94	5E	6,963
95	5F	7,037
96	60	7,111
97	61	7,185
98	62	7,259
99	63	7,333
100	64	7,407
101	65	7,481
102	66	7,556
103	67	7,630
104	68	7,704
105	69	7,778
106	6A	7,852
107	6B	7,926
108	6C	8,000
109	6D	8,074
110	6E	8,148
111	6F	8,222
112	70	8,296
113	71	8,370
114	72	8,444
115	73	8,519
116	74	8,593
117	75	8,667
118	76	8,741
119	77	8,815
120	78	8,889
121	79	8,963
122	7A	9,037
123	7B	9,111
124	7C	9,185
125	7D	9,259
126	7E	9,333
127	7F	9,407

ADC		VIN
Decimal	HEX	
128	80	9,481
129	81	9,556
130	82	9,630
131	83	9,704
132	84	9,778
133	85	9,852
134	86	9,926
135	87	10,000
136	88	10,074
137	89	10,148
138	8A	10,222
139	8B	10,296
140	8C	10,370
141	8D	10,444
142	8E	10,519
143	8F	10,593
144	90	10,667
145	91	10,741
146	92	10,815
147	93	10,889
148	94	10,963
149	95	11,037
150	96	11,111
151	97	11,185
152	98	11,259
153	99	11,333
154	9A	11,407
155	9B	11,481
156	9C	11,556
157	9D	11,630
158	9E	11,704
159	9F	11,778
160	A0	11,852
161	A1	11,926
162	A2	12,000
163	A3	12,074
164	A4	12,148
165	A5	12,222
166	A6	12,296
167	A7	12,370
168	A8	12,444
169	A9	12,519
170	AA	12,593
171	AB	12,667
172	AC	12,741
173	AD	12,815
174	AE	12,889
175	AF	12,963
176	B0	13,037
177	B1	13,111
178	B2	13,185
179	B3	13,259
180	B4	13,333
181	B5	13,407
182	B6	13,481
183	B7	13,556
184	B8	13,630
185	B9	13,704
186	BA	13,778
187	BB	13,852
188	BC	13,926
189	BD	14,000
190	BE	14,074
191	BF	14,148

ADC		VIN
Decimal	HEX	
192	C0	14,222
193	C1	14,296
194	C2	14,370
195	C3	14,444
196	C4	14,519
197	C5	14,593
198	C6	14,667
199	C7	14,741
200	C8	14,815
201	C9	14,889
202	CA	14,963
203	CB	15,037
204	CC	15,111
205	CD	15,185
206	CE	15,259
207	CF	15,333
208	DO	15,407
209	D1	15,481
210	D2	15,556
211	D3	15,630
212	D4	15,704
213	D5	15,778
214	D6	15,852
215	D7	15,926
216	D8	16,000
217	D9	16,074
218	DA	16,148
219	DB	16,222
220	DC	16,296
221	DD	16,370
222	DE	16,444
223	DF	16,519
224	E0	16,593
225	E1	16,667
226	E2	16,741
227	E3	16,815
228	E4	16,889
229	E5	16,963
230	E6	17,037
231	E7	17,111
232	E8	17,185
233	E9	17,259
234	EA	17,333
235	EB	17,407
236	EC	17,481
237	ED	17,556
238	EE	17,630
239	EF	17,704
240	FO	17,778
241	F1	17,852
242	F2	17,926
243	F3	18,000
244	F4	18,074
245	F5	18,148
246	F6	18,222
247	F7	18,296
248	F8	18,370
249	F9	18,444
250	FA	18,519
251	FB	18,593
252	FC	18,667
253	FD	18,741
254	FE	18,815
255	FF	18,889

ADC Temperature Conversion Chart

ADC		°C
Decimal	HEX	
0	0	-79.47
1	1	-71.78
2	2	-63.20
3	3	-57.81
4	4	-53.80
5	5	-50.58
6	6	-47.86
7	7	-45.49
8	8	-43.40
9	9	-41.51
10	A	-39.79
11	B	-38.20
12	C	-36.73
13	D	-35.35
14	E	-34.06
15	F	-32.83
16	10	-31.67
17	11	-30.57
18	12	-29.51
19	13	-28.50
20	14	-27.53
21	15	-26.59
22	16	-25.69
23	17	-24.82
24	18	-23.97
25	19	-23.15
26	1A	-22.36
27	1B	-21.59
28	1C	-20.83
29	1D	-20.10
30	1E	-19.38
31	1F	-18.68
32	20	-18.00
33	21	-17.33
34	22	-16.67
35	23	-16.03
36	24	-15.39
37	25	-14.77
38	26	-14.17
39	27	-13.57
40	28	-12.98
41	29	-12.40
42	2A	-11.83
43	2B	-11.26
44	2C	-10.71
45	2D	-10.16
46	2E	-9.62
47	2F	-9.09
48	30	-8.56
49	31	-8.04
50	32	-7.53
51	33	-7.02
52	34	-6.52
53	35	-6.02
54	36	-5.53
55	37	-5.04
56	38	-4.56
57	39	-4.08
58	3A	-3.61
59	3B	-3.14
60	3C	-2.67
61	3D	-2.21
62	3E	-1.75
63	3F	-1.29
64	40	-0.84
65	41	-0.39
66	42	0.05
67	43	0.49
68	44	0.93

ADC		°C
Decimal	HEX	
69	45	1.37
70	46	1.81
71	47	2.24
72	48	2.67
73	49	3.10
74	4A	3.52
75	4B	3.94
76	4C	4.37
77	4D	4.78
78	4E	5.20
79	4F	5.62
80	50	6.03
81	51	6.44
82	52	6.86
83	53	7.27
84	54	7.67
85	55	8.08
86	56	8.49
87	57	8.89
88	58	9.29
89	59	9.70
90	5A	10.10
91	5B	10.50
92	5C	10.90
93	5D	11.30
94	5E	11.70
95	5F	12.09
96	60	12.49
97	61	12.89
98	62	13.28
99	63	13.68
100	64	14.07
101	65	14.47
102	66	14.86
103	67	15.26
104	68	15.65
105	69	16.05
106	6A	16.44
107	6B	16.84
108	6C	17.23
109	6D	17.62
110	6E	18.02
111	6F	18.41
112	70	18.81
113	71	19.20
114	72	19.60
115	73	19.99
116	74	20.39
117	75	20.79
118	76	21.19
119	77	21.58
120	78	21.98
121	79	22.38
122	7A	22.78
123	7B	23.18
124	7C	23.59
125	7D	23.99
126	7E	24.39
127	7F	24.80
128	80	25.20
129	81	25.61
130	82	26.02
131	83	26.43
132	84	26.84
133	85	27.25
134	86	27.66
135	87	28.08
136	88	28.50
137	89	28.91

ADC		°C
Decimal	HEX	
138	8A	29.33
139	8B	29.76
140	8C	30.18
141	8D	30.60
142	8E	31.03
143	8F	31.46
144	90	31.89
145	91	32.32
146	92	32.76
147	93	33.20
148	94	33.64
149	95	34.08
150	96	34.53
151	97	34.97
152	98	35.42
153	99	35.88
154	9A	36.33
155	9B	36.79
156	9C	37.25
157	9D	37.72
158	9E	38.18
159	9F	38.66
160	A0	39.13
161	A1	39.61
162	A2	40.09
163	A3	40.57
164	A4	41.06
165	A5	41.56
166	A6	42.05
167	A7	42.56
168	A8	43.06
169	A9	43.57
170	AA	44.09
171	AB	44.61
172	AC	45.13
173	AD	45.66
174	AE	46.19
175	AF	46.73
176	B0	47.28
177	B1	47.83
178	B2	48.39
179	B3	48.95
180	B4	49.52
181	B5	50.09
182	B6	50.68
183	B7	51.27
184	B8	51.86
185	B9	52.47
186	BA	53.08
187	BB	53.70
188	BC	54.33
189	BD	54.96
190	BE	55.61
191	BF	56.26
192	C0	56.93
193	C1	57.60
194	C2	58.28
195	C3	58.98
196	C4	59.68
197	C5	60.40
198	C6	61.13
199	C7	61.87
200	C8	62.63
201	C9	63.39
202	CA	64.17
203	CB	64.97
204	CC	65.78
205	CD	66.61
206	CE	67.46

ADC		°C
Decimal	HEX	
207	CF	68.32
208	D0	69.20
209	D1	70.10
210	D2	71.02
211	D3	4.137
212	D4	4.157
213	D5	4.176
214	D6	4.196
215	D7	4.216
216	D8	4.235
217	D9	4.255
218	DA	4.275
219	DB	4.294
220	DC	4.314
221	DD	4.333
222	DE	4.353
223	DF	4.373
224	E0	4.392
225	E1	4.412
226	E2	4.431
227	E3	4.451
228	E4	4.471
229	E5	4.490
230	E6	4.510
231	E7	4.529
232	E8	4.549
233	E9	4.569
234	EA	4.588
235	EB	4.608
236	EC	4.627
237	ED	4.647
238	EE	4.667
239	EF	4.686
240	F0	4.706
241	F1	4.725
242	F2	4.745
243	F3	4.765
244	F4	4.784
245	F5	4.804
246	F6	4.824
247	F7	4.843
248	F8	4.863
249	F9	4.882
250	FA	4.902
251	FB	4.922
252	FC	4.941
253	FD	4.961
254	FE	4.980
255	FF	5.000

ADC Position Conversion Chart

ADC		degree	ADC		degree	ADC		degree	ADC		degree
Decimal	HEX		Decimal	HEX		Decimal	HEX		Decimal	HEX	
0	0	-166,650	69	45	-144,169	138	8A	-121,689	207	CF	-99,208
1	1	-166,324	70	46	-143,844	139	8B	-121,363	208	D0	-98,882
2	2	-165,998	71	47	-143,518	140	8C	-121,037	209	D1	-98,556
3	3	-165,673	72	48	-143,192	141	8D	-120,711	210	D2	-98,231
4	4	-165,347	73	49	-142,866	142	8E	-120,385	211	D3	-97,905
5	5	-165,021	74	4A	-142,540	143	8F	-120,060	212	D4	-97,579
6	6	-164,695	75	4B	-142,215	144	90	-119,734	213	D5	-97,253
7	7	-164,369	76	4C	-141,889	145	91	-119,408	214	D6	-96,927
8	8	-164,044	77	4D	-141,563	146	92	-119,082	215	D7	-96,602
9	9	-163,718	78	4E	-141,237	147	93	-118,756	216	D8	-96,276
10	A	-163,392	79	4F	-140,911	148	94	-118,431	217	D9	-95,950
11	B	-163,066	80	50	-140,585	149	95	-118,105	218	DA	-95,624
12	C	-162,740	81	51	-140,260	150	96	-117,779	219	DB	-95,298
13	D	-162,415	82	52	-139,934	151	97	-117,453	220	DC	-94,973
14	E	-162,089	83	53	-139,608	152	98	-117,127	221	DD	-94,647
15	F	-161,763	84	54	-139,282	153	99	-116,802	222	DE	-94,321
16	10	-161,437	85	55	-138,956	154	9A	-116,476	223	DF	-93,995
17	11	-161,111	86	56	-138,631	155	9B	-116,150	224	E0	-93,669
18	12	-160,785	87	57	-138,305	156	9C	-115,824	225	E1	-93,344
19	13	-160,460	88	58	-137,979	157	9D	-115,498	226	E2	-93,018
20	14	-160,134	89	59	-137,653	158	9E	-115,173	227	E3	-92,692
21	15	-159,808	90	5A	-137,327	159	9F	-114,847	228	E4	-92,366
22	16	-159,482	91	5B	-137,002	160	A0	-114,521	229	E5	-92,040
23	17	-159,156	92	5C	-136,676	161	A1	-114,195	230	E6	-91,715
24	18	-158,831	93	5D	-136,350	162	A2	-113,869	231	E7	-91,389
25	19	-158,505	94	5E	-136,024	163	A3	-113,544	232	E8	-91,063
26	1A	-158,179	95	5F	-135,698	164	A4	-113,218	233	E9	-90,737
27	1B	-157,853	96	60	-135,373	165	A5	-112,892	234	EA	-90,411
28	1C	-157,527	97	61	-135,047	166	A6	-112,566	235	EB	-90,085
29	1D	-157,202	98	62	-134,721	167	A7	-112,240	236	EC	-89,760
30	1E	-156,876	99	63	-134,395	168	A8	-111,915	237	ED	-89,434
31	1F	-156,550	100	64	-134,069	169	A9	-111,589	238	EE	-89,108
32	20	-156,224	101	65	-133,744	170	AA	-111,263	239	EF	-88,782
33	21	-155,898	102	66	-133,418	171	AB	-110,937	240	F0	-88,456
34	22	-155,573	103	67	-133,092	172	AC	-110,611	241	F1	-88,131
35	23	-155,247	104	68	-132,766	173	AD	-110,285	242	F2	-87,805
36	24	-154,921	105	69	-132,440	174	AE	-109,960	243	F3	-87,479
37	25	-154,595	106	6A	-132,115	175	AF	-109,634	244	F4	-87,153
38	26	-154,269	107	6B	-131,789	176	B0	-109,308	245	F5	-86,827
39	27	-153,944	108	6C	-131,463	177	B1	-108,982	246	F6	-86,502
40	28	-153,618	109	6D	-131,137	178	B2	-108,656	247	F7	-86,176
41	29	-153,292	110	6E	-130,811	179	B3	-108,331	248	F8	-85,850
42	2A	-152,966	111	6F	-130,485	180	B4	-108,005	249	F9	-85,524
43	2B	-152,640	112	70	-130,160	181	B5	-107,679	250	FA	-85,198
44	2C	-152,315	113	71	-129,834	182	B6	-107,353	251	FB	-84,873
45	2D	-151,989	114	72	-129,508	183	B7	-107,027	252	FC	-84,547
46	2E	-151,663	115	73	-129,182	184	B8	-106,702	253	FD	-84,221
47	2F	-151,337	116	74	-128,856	185	B9	-106,376	254	FE	-83,895
48	30	-151,011	117	75	-128,531	186	BA	-106,050	255	FF	-83,569
49	31	-150,685	118	76	-128,205	187	BB	-105,724	256	100	-83,244
50	32	-150,360	119	77	-127,879	188	BC	-105,398	257	101	-82,918
51	33	-150,034	120	78	-127,553	189	BD	-105,073	258	102	-82,592
52	34	-149,708	121	79	-127,227	190	BE	-104,747	259	103	-82,266
53	35	-149,382	122	7A	-126,902	191	BF	-104,421	260	104	-81,940
54	36	-149,056	123	7B	-126,576	192	C0	-104,095	261	105	-81,615
55	37	-148,731	124	7C	-126,250	193	C1	-103,769	262	106	-81,289
56	38	-148,405	125	7D	-125,924	194	C2	-103,444	263	107	-80,963
57	39	-148,079	126	7E	-125,598	195	C3	-103,118	264	108	-80,637
58	3A	-147,753	127	7F	-125,273	196	C4	-102,792	265	109	-80,311
59	3B	-147,427	128	80	-124,947	197	C5	-102,466	266	10A	-79,985
60	3C	-147,102	129	81	-124,621	198	C6	-102,140	267	10B	-79,660
61	3D	-146,776	130	82	-124,295	199	C7	-101,815	268	10C	-79,334
62	3E	-146,450	131	83	-123,969	200	C8	-101,489	269	10D	-79,008
63	3F	-146,124	132	84	-123,644	201	C9	-101,163	270	10E	-78,682
64	40	-145,798	133	85	-123,318	202	CA	-100,837	271	10F	-78,356
65	41	-145,473	134	86	-122,992	203	CB	-100,511	272	110	-78,031
66	42	-145,147	135	87	-122,666	204	CC	-100,185	273	111	-77,705
67	43	-144,821	136	88	-122,340	205	CD	-99,860	274	112	-77,379
68	44	-144,495	137	89	-122,015	206	CE	-99,534	275	113	-77,053

ADC		degree
Decimal	HEX	
276	114	-76.727
277	115	-76.402
278	116	-76.076
279	117	-75.750
280	118	-75.424
281	119	-75.098
282	11A	-74.773
283	11B	-74.447
284	11C	-74.121
285	11D	-73.795
286	11E	-73.469
287	11F	-73.144
288	120	-72.818
289	121	-72.492
290	122	-72.166
291	123	-71.840
292	124	-71.515
293	125	-71.189
294	126	-70.863
295	127	-70.537
296	128	-70.211
297	129	-69.885
298	12A	-69.560
299	12B	-69.234
300	12C	-68.908
301	12D	-68.582
302	12E	-68.256
303	12F	-67.931
304	130	-67.605
305	131	-67.279
306	132	-66.953
307	133	-66.627
308	134	-66.302
309	135	-65.976
310	136	-65.650
311	137	-65.324
312	138	-64.998
313	139	-64.673
314	13A	-64.347
315	13B	-64.021
316	13C	-63.695
317	13D	-63.369
318	13E	-63.044
319	13F	-62.718
320	140	-62.392
321	141	-62.066
322	142	-61.740
323	143	-61.415
324	144	-61.089
325	145	-60.763
326	146	-60.437
327	147	-60.111
328	148	-59.785
329	149	-59.460
330	14A	-59.134
331	14B	-58.808
332	14C	-58.482
333	14D	-58.156
334	14E	-57.831
335	14F	-57.505
336	150	-57.179
337	151	-56.853
338	152	-56.527
339	153	-56.202
340	154	-55.876
341	155	-55.550
342	156	-55.224
343	157	-54.898
344	158	-54.573
345	159	-54.247
346	15A	-53.921
347	15B	-53.595
348	15C	-53.269
349	15D	-52.944

ADC		degree
Decimal	HEX	
350	15E	-52.618
351	15F	-52.292
352	160	-51.966
353	161	-51.640
354	162	-51.315
355	163	-50.989
356	164	-50.663
357	165	-50.337
358	166	-50.011
359	167	-49.685
360	168	-49.360
361	169	-49.034
362	16A	-48.708
363	16B	-48.382
364	16C	-48.056
365	16D	-47.731
366	16E	-47.405
367	16F	-47.079
368	170	-46.753
369	171	-46.427
370	172	-46.102
371	173	-45.776
372	174	-45.450
373	175	-45.124
374	176	-44.798
375	177	-44.473
376	178	-44.147
377	179	-43.821
378	17A	-43.495
379	17B	-43.169
380	17C	-42.844
381	17D	-42.518
382	17E	-42.192
383	17F	-41.866
384	180	-41.540
385	181	-41.215
386	182	-40.889
387	183	-40.563
388	184	-40.237
389	185	-39.911
390	186	-39.585
391	187	-39.260
392	188	-38.934
393	189	-38.608
394	18A	-38.282
395	18B	-37.956
396	18C	-37.631
397	18D	-37.305
398	18E	-36.979
399	18F	-36.653
400	190	-36.327
401	191	-36.002
402	192	-35.676
403	193	-35.350
404	194	-35.024
405	195	-34.698
406	196	-34.373
407	197	-34.047
408	198	-33.721
409	199	-33.395
410	19A	-33.069
411	19B	-32.744
412	19C	-32.418
413	19D	-32.092
414	19E	-31.766
415	19F	-31.440
416	1A0	-31.115
417	1A1	-30.789
418	1A2	-30.463
419	1A3	-30.137
420	1A4	-29.811
421	1A5	-29.485
422	1A6	-29.160
423	1A7	-28.834

ADC		degree
Decimal	HEX	
424	1A8	-5.376
425	1A9	-5.050
426	1AA	-4.724
427	1AB	-28.508
428	1AC	-28.182
429	1AD	-27.856
430	1AE	-27.531
431	1AF	-27.205
432	1B0	-26.879
433	1B1	-26.553
434	1B2	-26.227
435	1B3	-25.902
436	1B4	-25.576
437	1B5	-25.250
438	1B6	-24.924
439	1B7	-24.598
440	1B8	-24.273
441	1B9	-23.947
442	1BA	-23.621
443	1BB	-23.295
444	1BC	-22.969
445	1BD	-22.644
446	1BE	-22.318
447	1BF	-21.992
448	1C0	-21.666
449	1C1	-21.340
450	1C2	-21.015
451	1C3	-20.689
452	1C4	-20.363
453	1C5	-20.037
454	1C6	-19.711
455	1C7	-19.385
456	1C8	-19.060
457	1C9	-18.734
458	1CA	-18.408
459	1CB	-18.082
460	1CC	-17.756
461	1CD	-17.431
462	1CE	-17.105
463	1CF	-16.779
464	1D0	-16.453
465	1D1	-16.127
466	1D2	-15.802
467	1D3	-15.476
468	1D4	-15.150
469	1D5	-14.824
470	1D6	-14.498
471	1D7	-14.173
472	1D8	-13.847
473	1D9	-13.521
474	1DA	-13.195
475	1DB	-12.869
476	1DC	-12.544
477	1DD	-12.218
478	1DE	-11.892
479	1DF	-11.566
480	1E0	-11.240
481	1E1	-10.915
482	1E2	-10.589
483	1E3	-10.263
484	1E4	-9.937
485	1E5	-9.611
486	1E6	-9.285
487	1E7	-8.960
488	1E8	-8.634
489	1E9	-8.308
490	1EA	-7.982
491	1EB	-7.656
492	1EC	-7.331
493	1ED	-7.005
494	1EE	-6.679
495	1EF	-6.353
496	1F0	-6.027
497	1F1	-5.702

ADC		degree
Decimal	HEX	
498	1F2	-4.398
499	1F3	-4.073
500	1F4	-3.747
501	1F5	-3.421
502	1F6	-3.095
503	1F7	-2.769
504	1F8	-2.444
505	1F9	-2.118
506	1FA	-1.792
507	1FB	-1.466
508	1FC	-1.140
509	1FD	-0.815
510	1FE	-0.489
511	1FF	-0.163
512	200	0.163
513	201	0.489
514	202	0.815
515	203	1.140
516	204	1.466
517	205	1.792
518	206	2.118
519	207	2.444
520	208	2.769
521	209	3.095
522	20A	3.421
523	20B	3.747
524	20C	4.073
525	20D	4.398
526	20E	4.724
527	20F	5.050
528	210	5.376
529	211	5.702
530	212	6.027
531	213	6.353
532	214	6.679
533	215	7.005
534	216	7.331
535	217	7.656
536	218	7.982
537	219	8.308
538	21A	8.634
539	21B	8.960
540	21C	9.285
541	21D	9.611
542	21E	9.937
543	21F	10.263
544	220	10.589
545	221	10.915
546	222	11.240
547	223	11.566
548	224	11.892
549	225	12.218
550	226	12.544
551	227	12.869
552	228	13.195
553	229	13.521
554	22A	13.847
555	22B	14.173
556	22C	14.498
557	22D	14.824
558	22E	15.150
559	22F	15.476
560	230	15.802
561	231	16.127
562	232	16.453
563	233	16.779
564	234	17.105
565	235	17.431
566	236	17.756
567	237	18.082
568	238	18.408
569	239	18.734
570	23A	19.060
571	23B	19.385

ADC			ADC			ADC			ADC		
Decimal	HEX	degree	Decimal	HEX	degree	Decimal	HEX	degree	Decimal	HEX	degree
572	23C	19,711	646	286	43,821	720	2D0	67,931	794	31A	92,040
573	23D	20,037	647	287	44,147	721	2D1	68,256	795	31B	92,366
574	23E	20,363	648	288	44,473	722	2D2	68,582	796	31C	92,692
575	23F	20,689	649	289	44,798	723	2D3	68,908	797	31D	93,018
576	240	21,015	650	28A	45,124	724	2D4	69,234	798	31E	93,344
577	241	21,340	651	28B	45,450	725	2D5	69,560	799	31F	93,669
578	242	21,666	652	28C	45,776	726	2D6	69,885	800	320	93,995
579	243	21,992	653	28D	46,102	727	2D7	70,211	801	321	94,321
580	244	22,318	654	28E	46,427	728	2D8	70,537	802	322	94,647
581	245	22,644	655	28F	46,753	729	2D9	70,863	803	323	94,973
582	246	22,969	656	290	47,079	730	2DA	71,189	804	324	95,298
583	247	23,295	657	291	47,405	731	2DB	71,515	805	325	95,624
584	248	23,621	658	292	47,731	732	2DC	71,840	806	326	95,950
585	249	23,947	659	293	48,056	733	2DD	72,166	807	327	96,276
586	24A	24,273	660	294	48,382	734	2DE	72,492	808	328	96,602
587	24B	24,598	661	295	48,708	735	2DF	72,818	809	329	96,927
588	24C	24,924	662	296	49,034	736	2E0	73,144	810	32A	97,253
589	24D	25,250	663	297	49,360	737	2E1	73,469	811	32B	97,579
590	24E	25,576	664	298	49,685	738	2E2	73,795	812	32C	97,905
591	24F	25,902	665	299	50,011	739	2E3	74,121	813	32D	98,231
592	250	26,227	666	29A	50,337	740	2E4	74,447	814	32E	98,556
593	251	26,553	667	29B	50,663	741	2E5	74,773	815	32F	98,882
594	252	26,879	668	29C	50,989	742	2E6	75,098	816	330	99,208
595	253	27,205	669	29D	51,315	743	2E7	75,424	817	331	99,534
596	254	27,531	670	29E	51,640	744	2E8	75,750	818	332	99,860
597	255	27,856	671	29F	51,966	745	2E9	76,076	819	333	100,185
598	256	28,182	672	2A0	52,292	746	2EA	76,402	820	334	100,511
599	257	28,508	673	2A1	52,618	747	2EB	76,727	821	335	100,837
600	258	28,834	674	2A2	52,944	748	2EC	77,053	822	336	101,163
601	259	29,160	675	2A3	53,269	749	2ED	77,379	823	337	101,489
602	25A	29,485	676	2A4	53,595	750	2EE	77,705	824	338	101,815
603	25B	29,811	677	2A5	53,921	751	2EF	78,031	825	339	102,140
604	25C	30,137	678	2A6	54,247	752	2F0	78,356	826	33A	102,466
605	25D	30,463	679	2A7	54,573	753	2F1	78,682	827	33B	102,792
606	25E	30,789	680	2A8	54,898	754	2F2	79,008	828	33C	103,118
607	25F	31,115	681	2A9	55,224	755	2F3	79,334	829	33D	103,444
608	260	31,440	682	2AA	55,550	756	2F4	79,660	830	33E	103,769
609	261	31,766	683	2AB	55,876	757	2F5	79,985	831	33F	104,095
610	262	32,092	684	2AC	56,202	758	2F6	80,311	832	340	104,421
611	263	32,418	685	2AD	56,527	759	2F7	80,637	833	341	104,747
612	264	32,744	686	2AE	56,853	760	2F8	80,963	834	342	105,073
613	265	33,069	687	2AF	57,179	761	2F9	81,289	835	343	105,398
614	266	33,395	688	2B0	57,505	762	2FA	81,615	836	344	105,724
615	267	33,721	689	2B1	57,831	763	2FB	81,940	837	345	106,050
616	268	34,047	690	2B2	58,156	764	2FC	82,266	838	346	106,376
617	269	34,373	691	2B3	58,482	765	2FD	82,592	839	347	106,702
618	26A	34,698	692	2B4	58,808	766	2FE	82,918	840	348	107,027
619	26B	35,024	693	2B5	59,134	767	2FF	83,244	841	349	107,353
620	26C	35,350	694	2B6	59,460	768	300	83,569	842	34A	107,679
621	26D	35,676	695	2B7	59,785	769	301	83,895	843	34B	108,005
622	26E	36,002	696	2B8	60,111	770	302	84,221	844	34C	108,331
623	26F	36,327	697	2B9	60,437	771	303	84,547	845	34D	108,656
624	270	36,653	698	2BA	60,763	772	304	84,873	846	34E	108,982
625	271	36,979	699	2BB	61,089	773	305	85,198	847	34F	109,308
626	272	37,305	700	2BC	61,415	774	306	85,524	848	350	109,634
627	273	37,631	701	2BD	61,740	775	307	85,850	849	351	109,960
628	274	37,956	702	2BE	62,066	776	308	86,176	850	352	110,285
629	275	38,282	703	2BF	62,392	777	309	86,502	851	353	110,611
630	276	38,608	704	2C0	62,718	778	30A	86,827	852	354	110,937
631	277	38,934	705	2C1	63,044	779	30B	87,153	853	355	111,263
632	278	39,260	706	2C2	63,369	780	30C	87,479	854	356	111,589
633	279	39,585	707	2C3	63,695	781	30D	87,805	855	357	111,915
634	27A	39,911	708	2C4	64,021	782	30E	88,131	856	358	112,240
635	27B	40,237	709	2C5	64,347	783	30F	88,456	857	359	112,566
636	27C	40,563	710	2C6	64,673	784	310	88,782	858	35A	112,892
637	27D	40,889	711	2C7	64,998	785	311	89,108	859	35B	113,218
638	27E	41,215	712	2C8	65,324	786	312	89,434	860	35C	113,544
639	27F	41,540	713	2C9	65,650	787	313	89,760	861	35D	113,869
640	280	41,866	714	2CA	65,976	788	314	90,085	862	35E	114,195
641	281	42,192	715	2CB	66,302	789	315	90,411	863	35F	114,521
642	282	42,518	716	2CC	66,627	790	316	90,737	864	360	114,847
643	283	42,844	717	2CD	66,953	791	317	91,063	865	361	115,173
644	284	43,169	718	2CE	67,279	792	318	91,389	866	362	115,498
645	285	43,495	719	2CF	67,605	793	319	91,715	867	363	115,824

ADC		degree
Decimal	HEX	
868	364	116,150
869	365	116,476
870	366	116,802
871	367	117,127
872	368	117,453
873	369	117,779
874	36A	118,105
875	36B	118,431
876	36C	118,756
877	36D	119,082
878	36E	119,408
879	36F	119,734
880	370	120,060
881	371	120,385
882	372	120,711
883	373	121,037
884	374	121,363
885	375	121,689
886	376	122,015
887	377	122,340
888	378	122,666
889	379	122,992
890	37A	123,318
891	37B	123,644
892	37C	123,969
893	37D	124,295
894	37E	124,621
895	37F	124,947
896	380	125,273
897	381	125,598
898	382	125,924
899	383	126,250
900	384	126,576
901	385	126,902
902	386	127,227
903	387	127,553
904	388	127,879
905	389	128,205
906	38A	128,531
907	38B	128,856
908	38C	129,182
909	38D	129,508
910	38E	129,834
911	38F	130,160
912	390	130,485
913	391	130,811
914	392	131,137
915	393	131,463
916	394	131,789
917	395	132,115
918	396	132,440
919	397	132,766
920	398	133,092
921	399	133,418
922	39A	133,744
923	39B	134,069
924	39C	134,395
925	39D	134,721
926	39E	135,047
927	39F	135,373
928	3A0	135,698
929	3A1	136,024
930	3A2	136,350
931	3A3	136,676
932	3A4	137,002
933	3A5	137,327
934	3A6	137,653
935	3A7	137,979
936	3A8	138,305
937	3A9	138,631
938	3AA	138,956
939	3AB	139,282
940	3AC	139,608
941	3AD	139,934

ADC		degree
Decimal	HEX	
942	3AE	140,260
943	3AF	140,585
944	3B0	140,911
945	3B1	141,237
946	3B2	141,563
947	3B3	141,889
948	3B4	142,215
949	3B5	142,540
950	3B6	142,866
951	3B7	143,192
952	3B8	143,518
953	3B9	143,844
954	3BA	144,169
955	3BB	144,495
956	3BC	144,821
957	3BD	145,147
958	3BE	145,473
959	3BF	145,798
960	3C0	146,124
961	3C1	146,450
962	3C2	146,776
963	3C3	147,102
964	3C4	147,427
965	3C5	147,753
966	3C6	148,079
967	3C7	148,405
968	3C8	148,731
969	3C9	149,056
970	3CA	149,382
971	3CB	149,708
972	3CC	150,034
973	3CD	150,360
974	3CE	150,685
975	3CF	151,011
976	3D0	151,337
977	3D1	151,663
978	3D2	151,989
979	3D3	152,315
980	3D4	152,640
981	3D5	152,966
982	3D6	153,292
983	3D7	153,618
984	3D8	153,944
985	3D9	154,269
986	3DA	154,595
987	3DB	154,921
988	3DC	155,247
989	3DD	155,573
990	3DE	155,898
991	3DF	156,224
992	3E0	156,550
993	3E1	156,876
994	3E2	157,202
995	3E3	157,527
996	3E4	157,853
997	3E5	158,179
998	3E6	158,505
999	3E7	158,831
1000	3E8	159,156
1001	3E9	159,482
1002	3EA	159,808
1003	3EB	160,134
1004	3EC	160,460
1005	3ED	160,785
1006	3EE	161,111
1007	3EF	161,437
1008	3F0	161,763
1009	3F1	162,089
1010	3F2	162,415
1011	3F3	162,740
1012	3F4	163,066
1013	3F5	163,392
1014	3F6	163,718
1015	3F7	164,044

ADC		degree
Decimal	HEX	
1016	3F8	164,369
1017	3F9	164,695
1018	3FA	165,021
1019	3FB	165,347
1020	3FC	165,673
1021	3FD	165,998
1022	3FE	166,324
1023	3FF	166,650

X-ON Electronics

Largest Supplier of Electrical and Electronic Components

Click to view similar products for [Servo Motors](#) category:

Click to view products by [DF Robot](#) manufacturer:

Other Similar products are found below :

[FIT0045](#) [FIT0046](#) [SER0006](#) [SER0011](#) [SER0019](#) [SER0035](#) [SER0038](#) [SER0039](#)