

REVISIONS				
P.	LTN	DESCRIPTION	DATE	APP'D
B5		REVISED PER ECO-13-020287	16JAN2014	DD DS
B6		REVISED PER ECO-15-000098	06JAN2015	DD DS
B7		REVISED PER ECO-15-003872	25MAR2015	DD DS

- △ ACCEPTS #3 SELF TAPPING THREAD FORMING SCREWS OR METRIC EQUIVALENT. DRIVE TO 0.6-0.8 N-m.
- △ HOUSING COLORS ARE MECHANICALLY KEYS TO MATE ONLY WITH IDENTICALLY COLORED PLUG ASSEMBLIES.
- 3. HEADER MATES TO PLUG ASSEMBLY 776273 WHICH USES REELED TERMINAL 770520 AND LOOSE PIECE TERMINAL 770854
- △ MATERIAL: HEADER HOUSING - GLASS FILLED PBT
PIN - TIN OR GOLD PLATED BRASS
- △ DATE CODE TO BE BRANDED ON THIS SURFACE PER TE SPEC 102-60. USE 5 DIGIT CODE: FIRST 2 DIGITS = YEAR, SECOND 2 DIGITS = WEEK, LAST DIGIT = DAY.

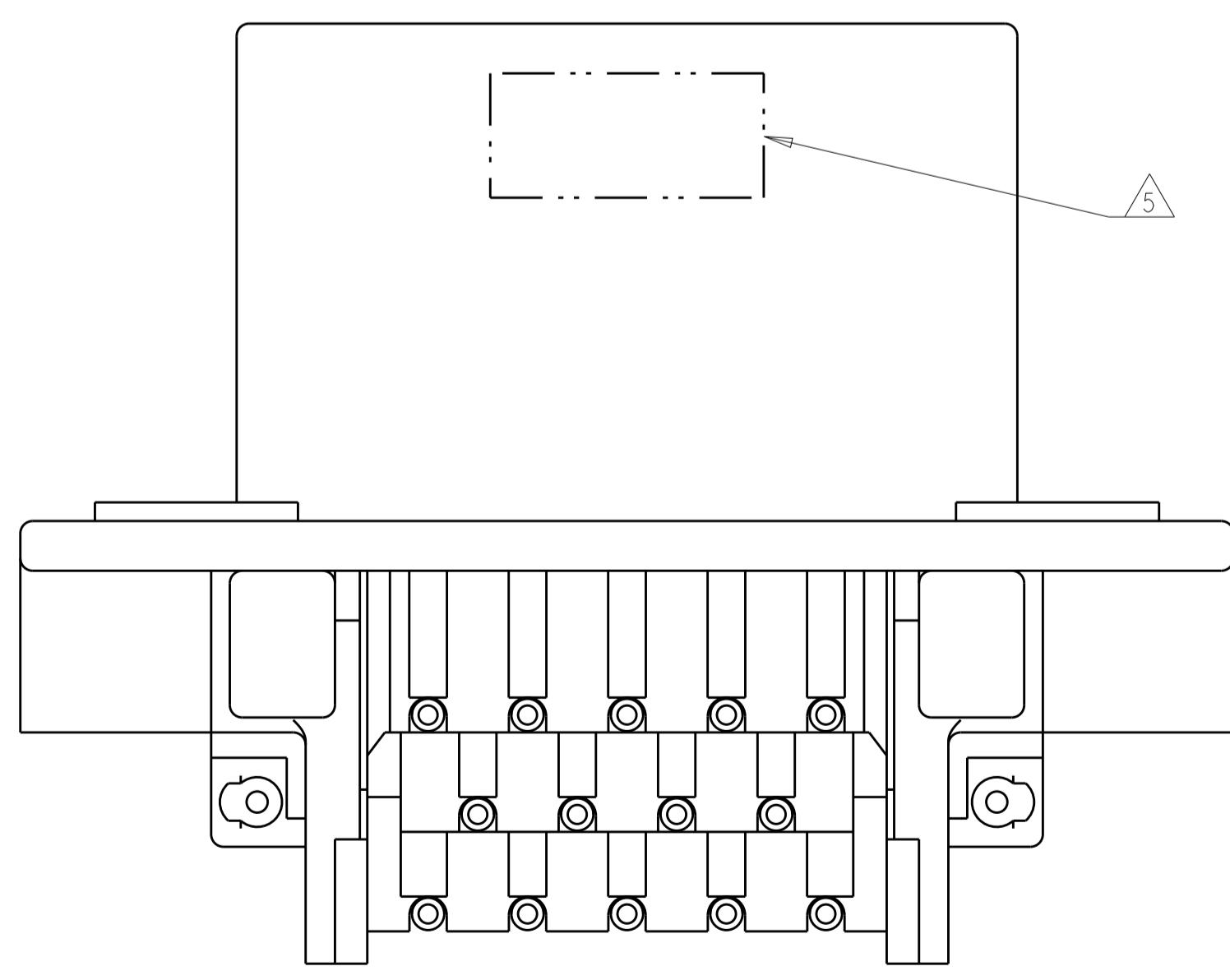
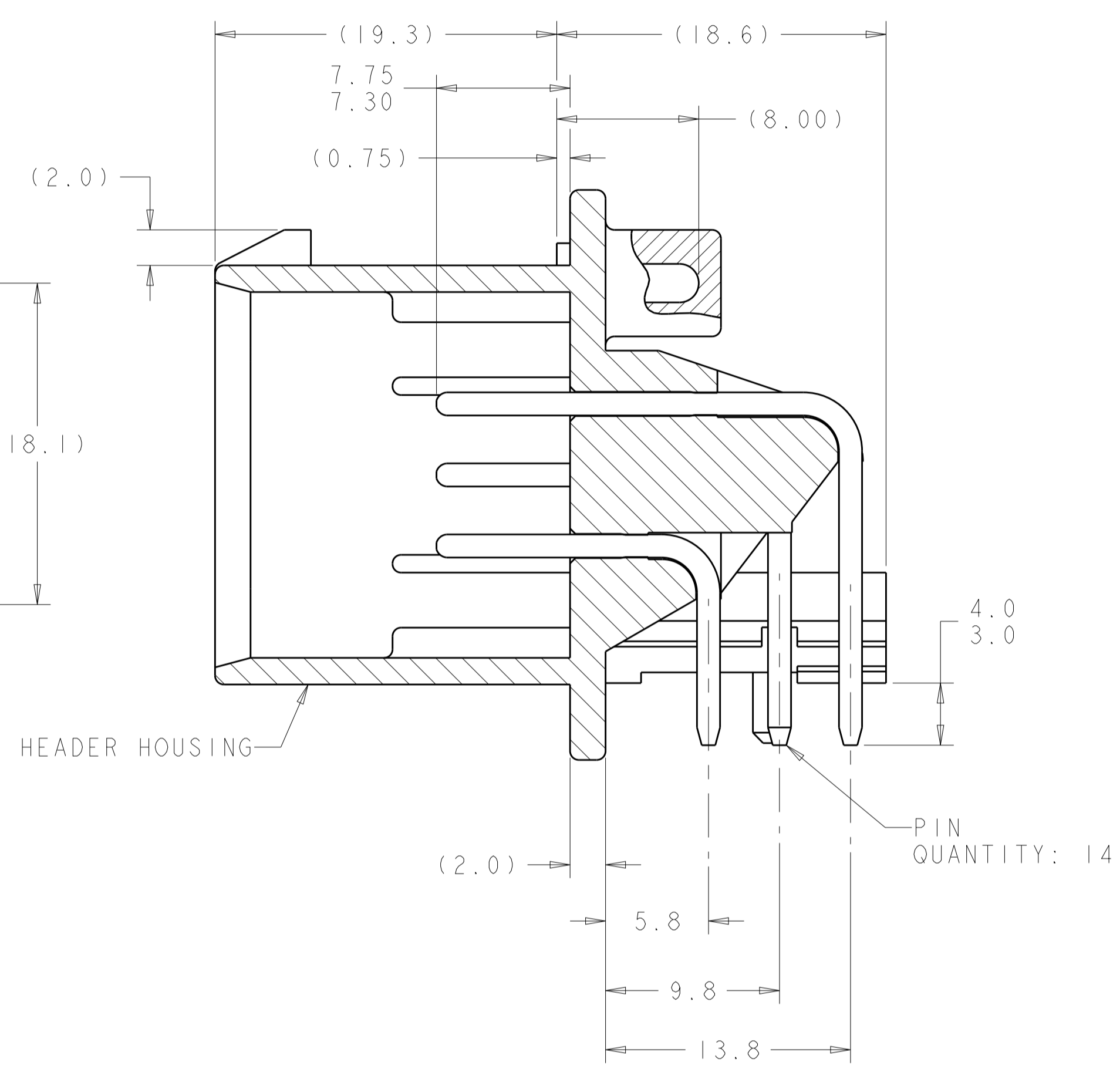
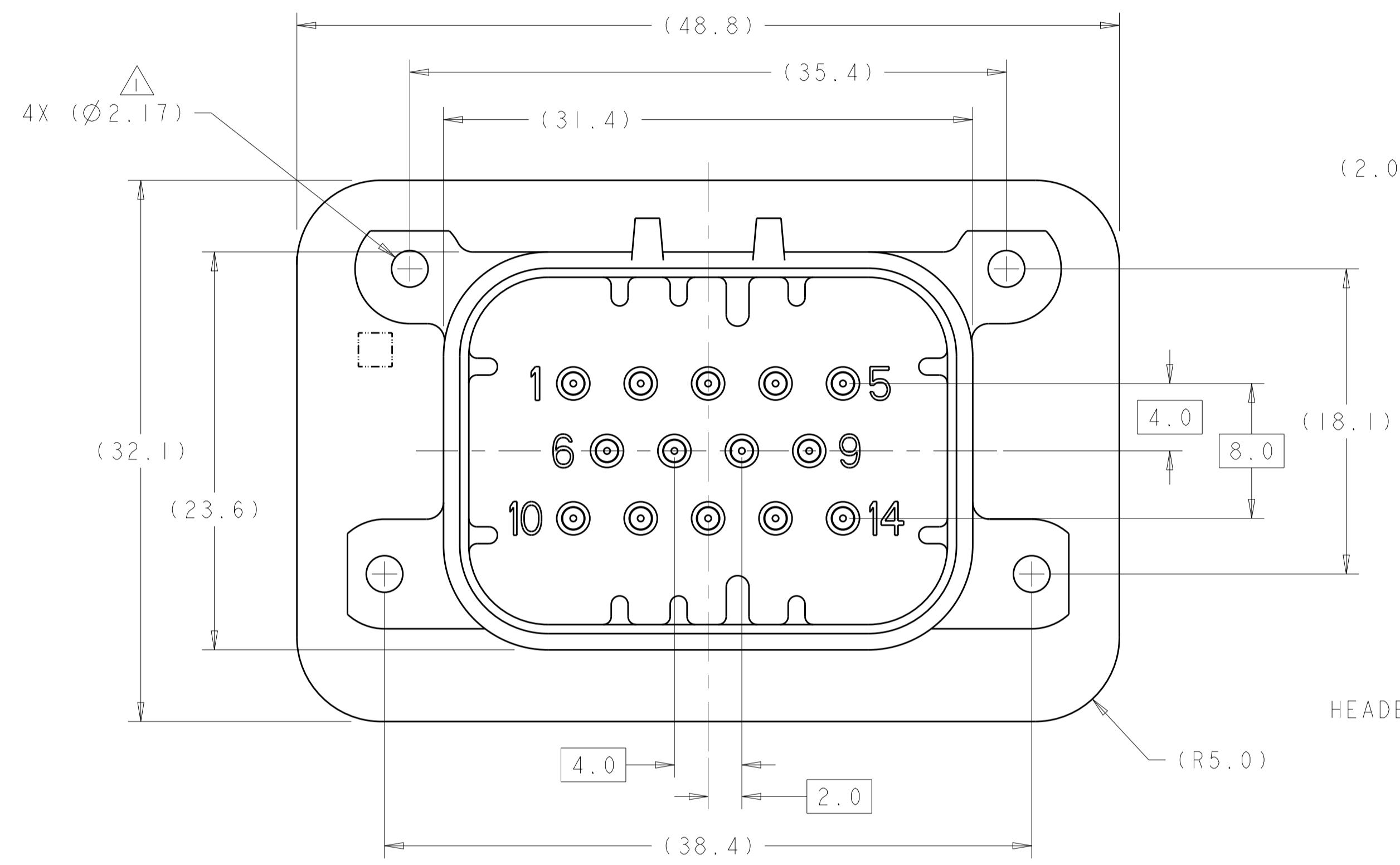

776266-1 & 1-776266-1 SHOWN

HEADER HOUSING COLOR	DESCRIPTION	PART NUMBER
BLUE	DURAGOLD PLATED	1-776266-5
GRAY	DURAGOLD PLATED	1-776266-4
NATURAL	DURAGOLD PLATED	1-776266-2
BLACK	DURAGOLD PLATED	1-776266-1
BLUE	TIN PLATED	776266-5
GRAY	TIN PLATED	776266-4
NATURAL	TIN PLATED	776266-2
BLACK	TIN PLATED	776266-1

THIS DRAWING IS A CONTROLLED DOCUMENT.

DWN: D. DRUMMOND 18AUG2010
 CHK: D. STRAUSSER 18AUG2010
 APVD: D. STRAUSSER 18AUG2010

DIMENSIONS: mm
 TOLERANCES UNLESS OTHERWISE SPECIFIED:
 0 PLC ±0.2
 1 PLC ±0.13
 2 PLC ±0.13
 3 PLC ±0.13
 4 PLC ±0.13
 ANGLES ±0.5°

MATERIAL: 4
 FINISH: 4

THIS DRAWING IS A CONTROLLED DOCUMENT.
 DWN: D. DRUMMOND 18AUG2010
 CHK: D. STRAUSSER 18AUG2010
 APVD: D. STRAUSSER 18AUG2010

NAME: HEATER ASSEMBLY, 14 POSITION, RIGHT ANGLE, AMPSEAL
 PRODUCT SPEC: 108-1329
 APPLICATION SPEC: 114-16016
 WEIGHT: -
 CUSTOMER DRAWING

SCALE: 4:1
 SHEET: 1 OF 2
 REV: B7

REVISIONS				
P.	LTH	DESCRIPTION	DATE	APPV
-	-	SEE SHEET 1	-	-

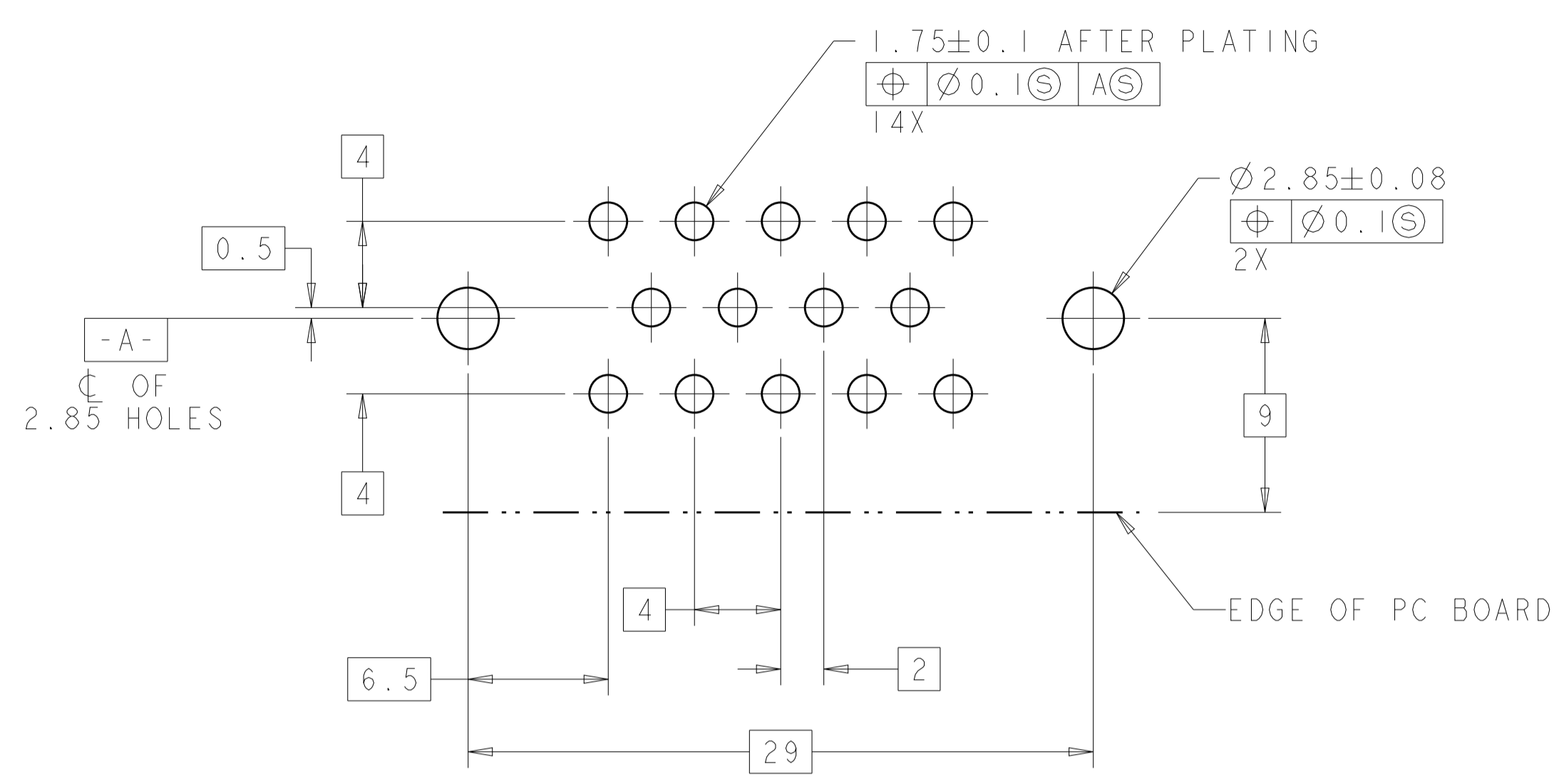

RECOMMENDED PC BOARD LAYOUT FOR 1.57 PC BOARD

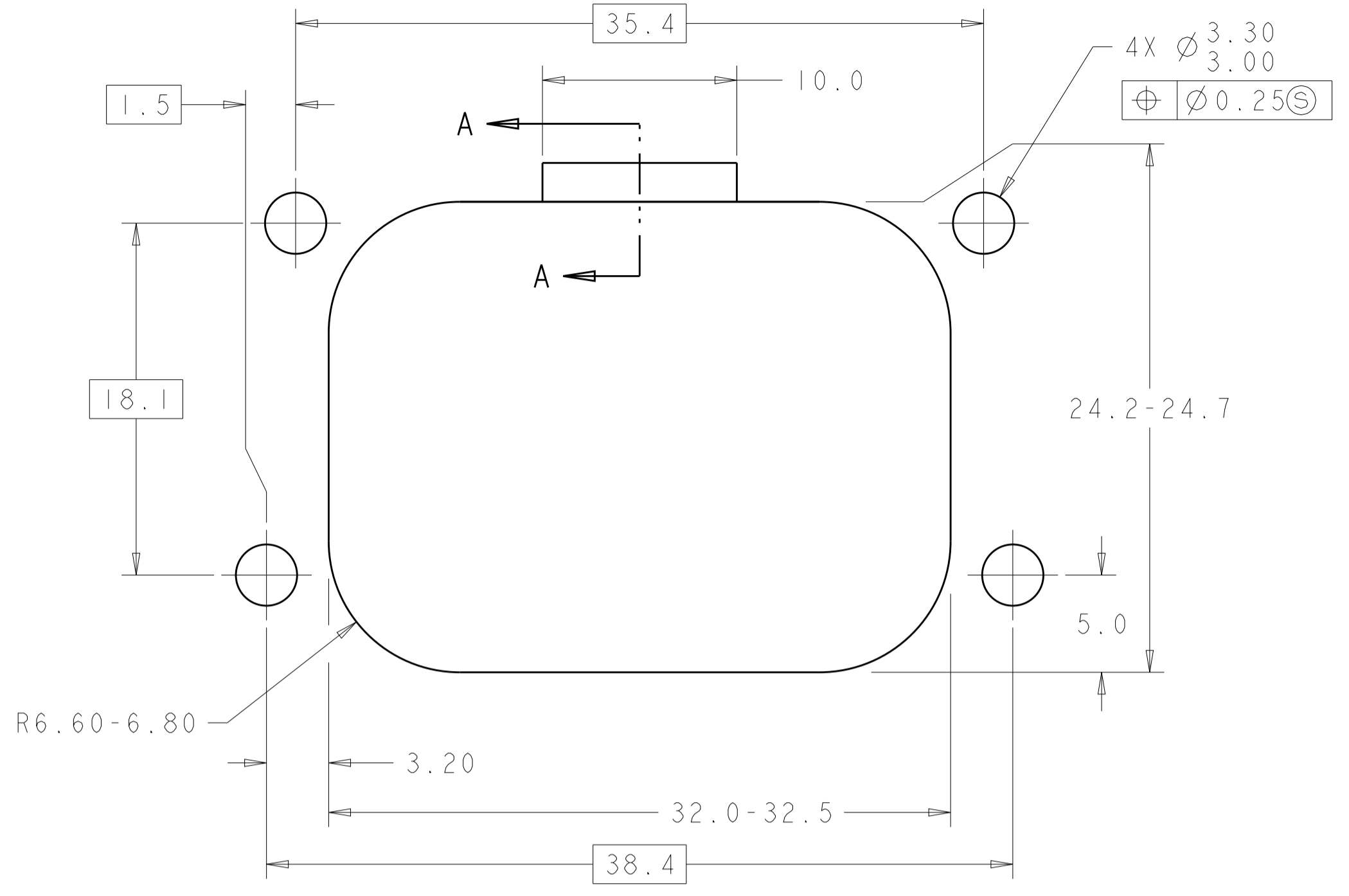

RECOMMENDED MOUNTING HOLE LAYOUT FOR 5.0 MAXIMUM THICK PANEL

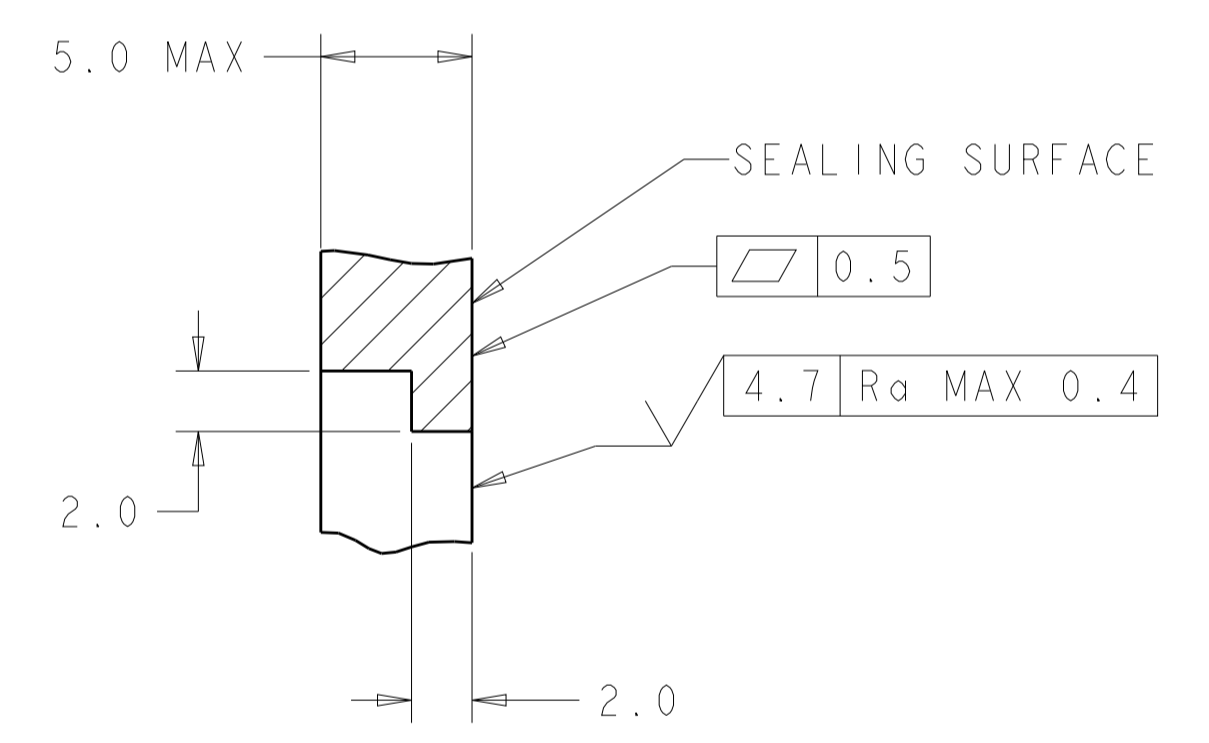
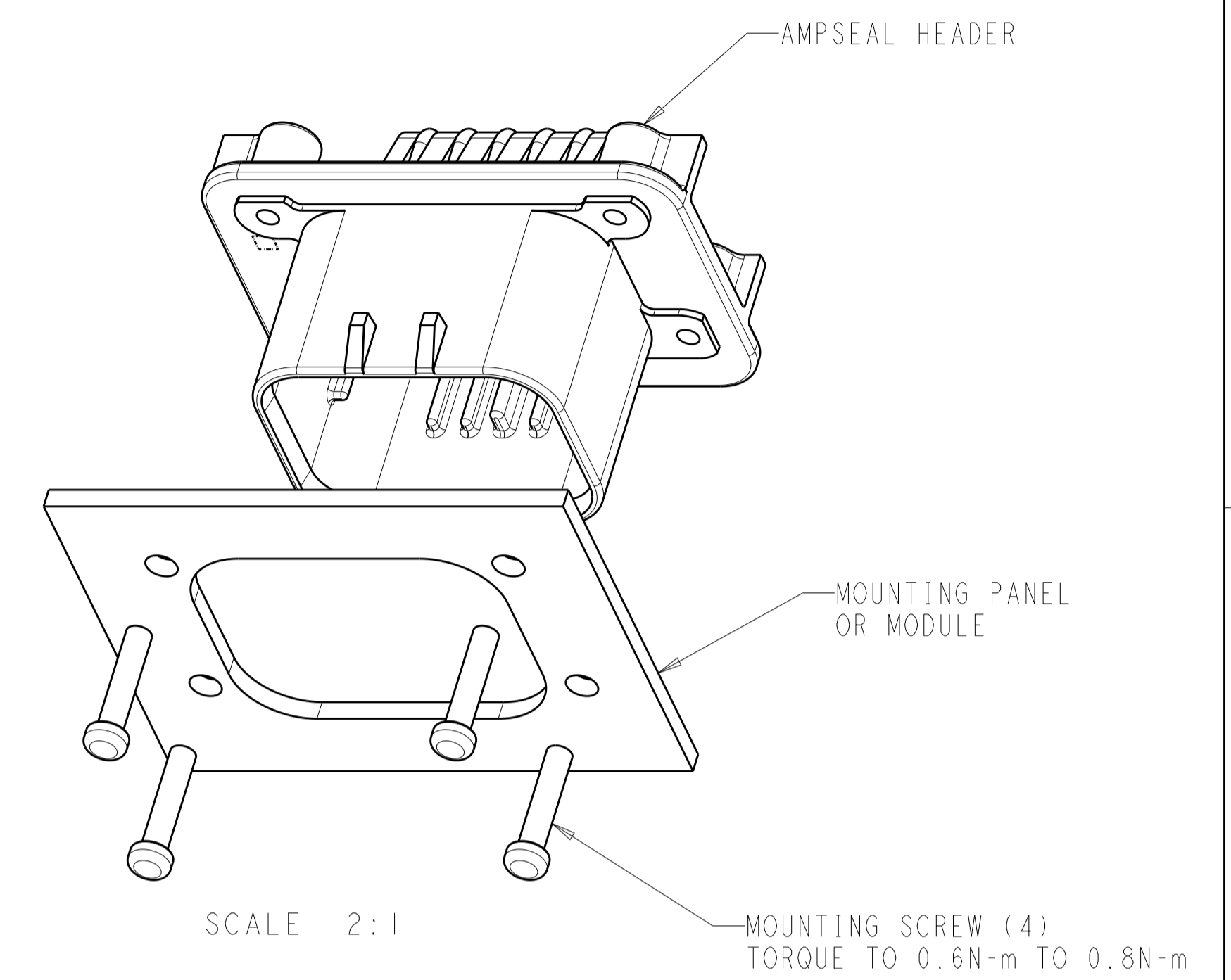

SECTION A-A
 OPTIONAL CONSTRUCTION IF THICKNESS IS GREATER THEN 2.0

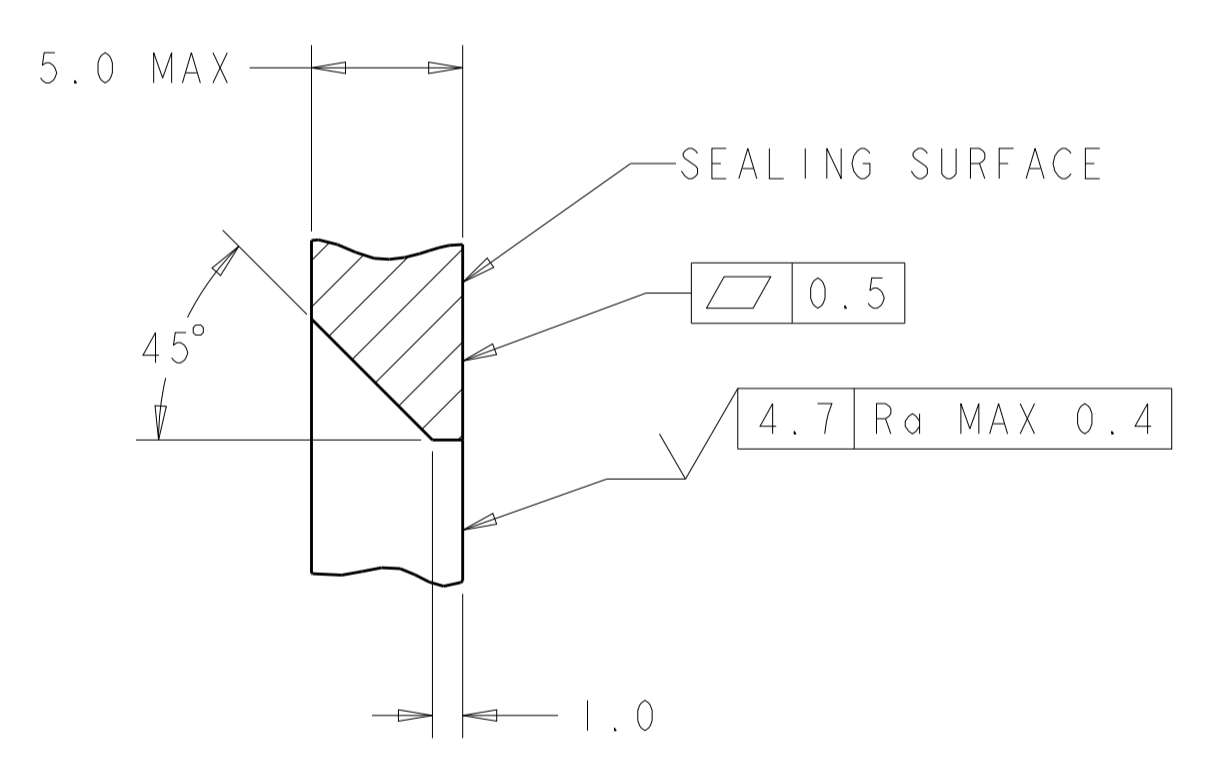

SECTION A-A
 OPTIONAL CONSTRUCTION IF THICKNESS IS GREATER THEN 2.0

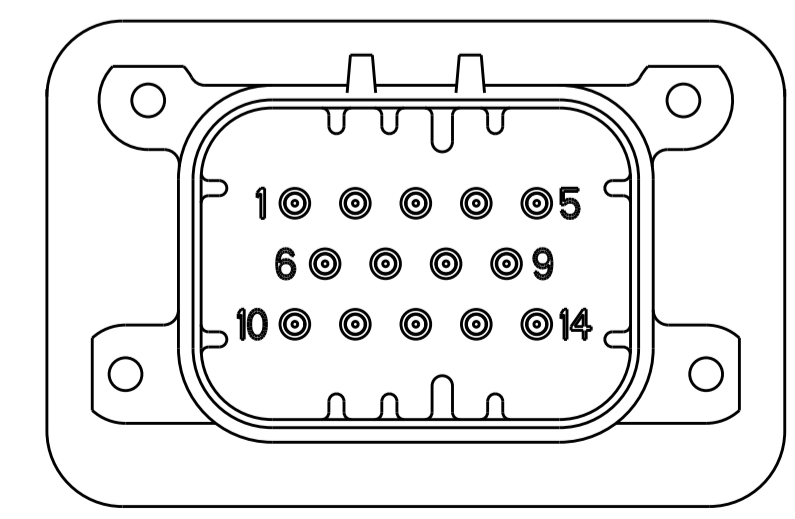
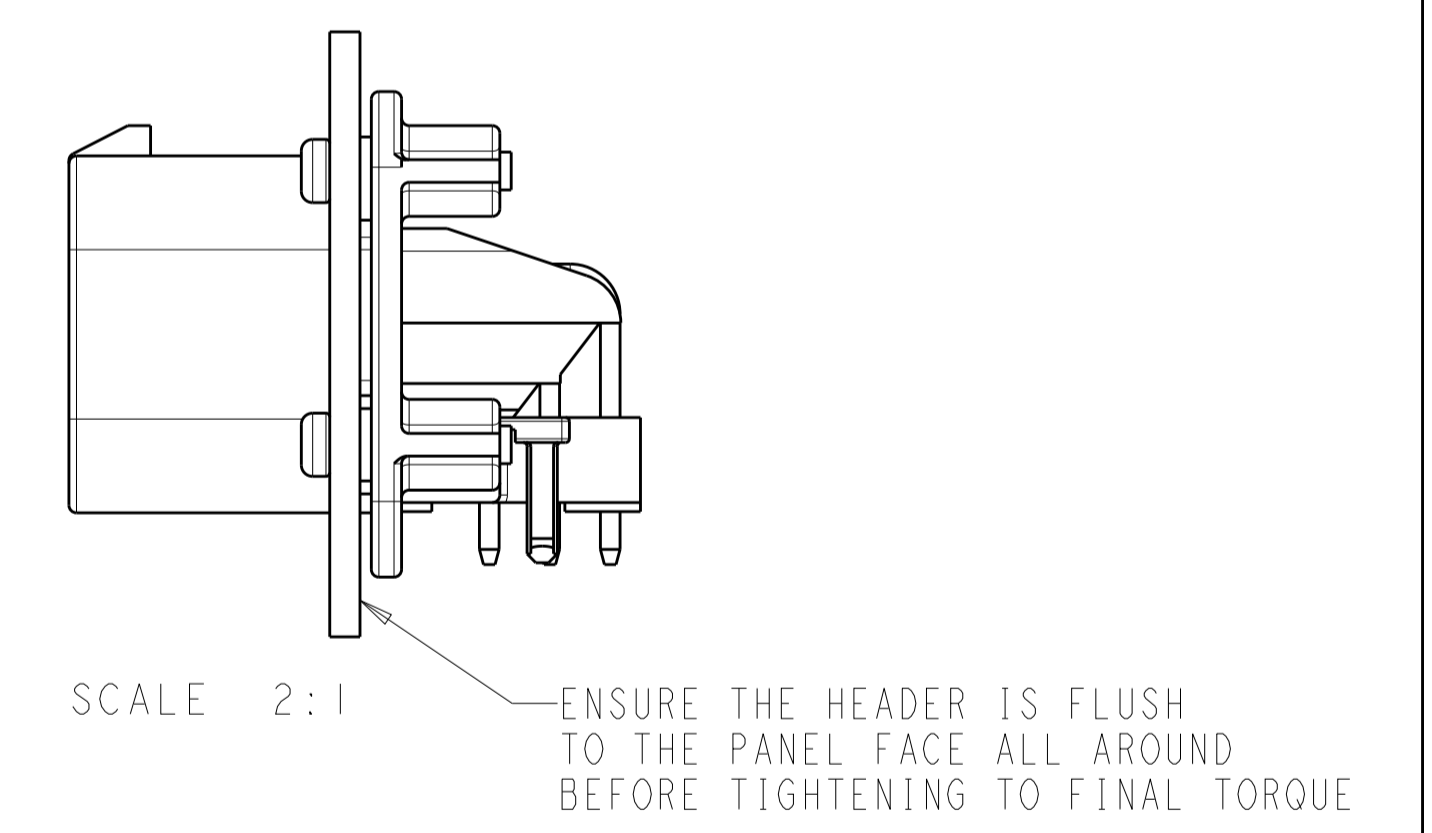

776266-1 & 1-776266-1
 KEY LOCATION
 SCALE 2:1

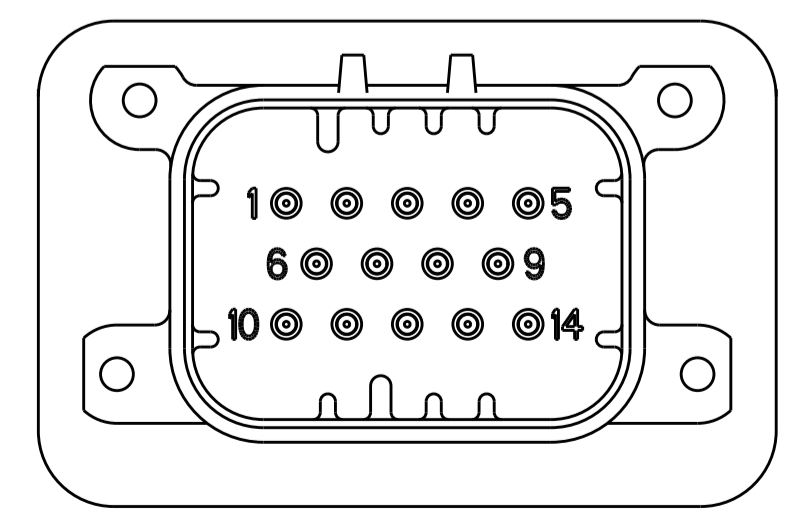

776266-2 & 1-776266-2
 KEY LOCATION
 SCALE 2:1

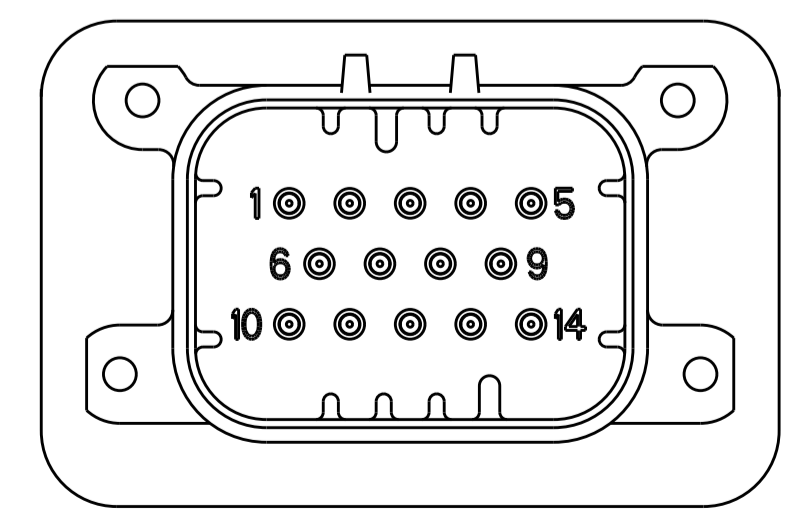

776266-4 & 1-776266-4
 KEY LOCATION
 SCALE 2:1

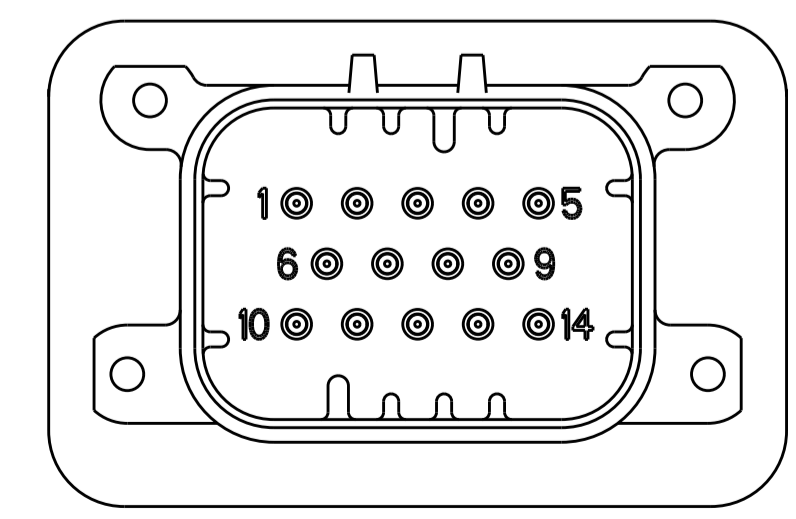

776266-5 & 1-776266-5
 KEY LOCATION
 SCALE 2:1

THIS DRAWING IS A CONTROLLED DOCUMENT.		OWN: D. DRUMMOND 18AUG2010	TE Connectivity
DIMENSIONS: mm		CHK: D. STRAUSSER 18AUG2010	
TOLERANCES UNLESS OTHERWISE SPECIFIED:		APVD: D. STRAUSSER 18AUG2010	NAME: HEADER ASSEMBLY, 14 POSITION, RIGHT ANGLE, AMPSEAL
0 PLC	±	PRODUCT SPEC	SIZE: CAGE CODE DRAWING NO
1 PLC	±0.2	108-1329	RESTRICTED TO
2 PLC	±0.13	APPLICATION SPEC	A100779C=776266
3 PLC	±	114-16016	SCALE: 4:1 SHEET 2 OF 2 REV: B7
4 PLC	±	WEIGHT	
ANGLES	±45°	CUSTOMER DRAWING	

X-ON Electronics

Largest Supplier of Electrical and Electronic Components

Click to view similar products for [Automotive Connectors](#) category:

Click to view products by [TE Connectivity](#) manufacturer:

Other Similar products are found below :

[003-018-000](#) [600858](#) [60403001](#) [60993906-B](#) [60993913-B](#) [629515004020001](#) [M902-2131](#) [M902-2161](#) [M902-2344](#) [72.330.1035.1](#)
[73.353.4028.0](#) [F118010](#) [F119300-B](#) [F132210](#) [F132210-B](#) [F166900](#) [F180100](#) [F258300](#) [F258300-B](#) [F294300-B](#) [F339100](#) [F339700](#) [F358300-](#)
[B](#) [F374110](#) [F407400](#) [F412210](#) [F427600](#) [F444110](#) [F487000](#) [F495100-B](#) [F500900-B](#) [F509500B-B](#) [770444-1](#) [776880-1](#) [827153-1](#) [881735-1](#)
[8N1515-32-24P](#) [9-1326727-8](#) [9-1326729-8](#) [925467-1](#) [925474-1](#) [928905-1](#) [936398-2](#) [964562-1](#) [964562-4](#) [964731-2](#) [965051-1](#) [968782-1](#)
[GT17SA-8DS-HU](#) [GT17VS-10DP-5.2CF](#)