



CXTLA02

SOLID STATE, LOW RANGE, ANALOG SERIES

- Small, Low-Cost, Rugged
- Vibration Resistant
- $\pm 20^\circ$ Range, 100 mV/ $^\circ$ Output
- Fully Conditioned Analog Outputs

Applications

- Scissor Lifts
- Static Platforms
- Alignment Systems
- Laser Leveling



CXTLA02

The CXTLA dual-axis analog tilt sensor offers high-resolution, accuracy, and fast response in an inexpensive, easy-to-use package. The CXTLA series design centers on a highly stable silicon micro-machined capacitive inclination sensor element. The CXTLA series is fully signal conditioned with high level analog output(s), and optional analog temperature signal.

Micro-machined devices, perfected in automotive safety applications, offer several distinct advantages over fluid, electrolytic, and pendulum-based sensors. Like other solid-state devices, they are more reliable than their mechanical counterparts. In a package smaller than many pendulum or fluid sensing elements, completely integrated electronics eliminate the need for external components.

Unlike other micro-machined devices, the CXTLA Series maintains its accuracy and stability over temperature: $< 2^\circ$ of arc over the range 0° to 70° C. The output can be user corrected for temperature with the -T option, yielding accuracy to within $\pm 0.5^\circ$ over the angular range.

A typical configuration using CXTLA sensors is shown below. Each module is factory calibrated, tested and includes a calibration sheet. The module can be securely attached using screws or adhesive. The CXTLA is available in a standard nylon or high temperature aluminum pack-

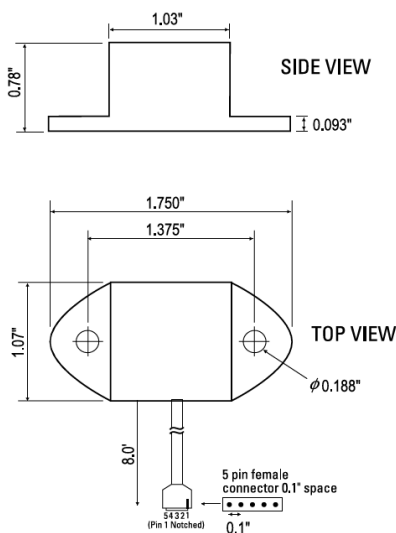

Micromachined Tilt Sensor Element

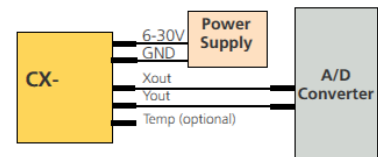

Typical CXTLA02 Configuration

Specifications	CXTLA02	Remarks
Performance		
Angular Range (°)	± 20	
Angular Resolution (° rms)	0.03	
Sensitivity - small angles (mV/°)	100 ± 10	Actual value provided with Sensor
Sensitivity Drift (%/°C)	0.01	
Zero Angle Voltage (Volts)	2.5 ± 0.15	Actual value provided with Sensor
Zero Angle Drift (mV/°C)	3	Typical
Zero Angle Drift (°/°C)	0.03	Typical
Non-Linearity (°) ¹	< 0.4	Over ± 20°
Bandwidth (Hz)	6	
Alignment (°)	± 1	Typical
Cross-axis Sensitivity (%)	< 5	Inclusive of alignment error
Environment		
Storage Temperature (°C)	-55 to +85	Nylon Package
Operating Temperature (°C)	-40 to +85	Nylon Package
Storage Temperature (°C)	-55 to +105	-AL High Temperature Package
Operating Temperature (°C)	-40 to +105	-AL High Temperature Package
Non-Operating Vibration (g rms)	10	20-2 kHz random
Shock (g)	2000	1 ms, half sine
Electrical		
Supply Voltage (VDC)	6 - 30	Unregulated
Current (mA)	8	
Physical		
Size (Nylon Package)	(1.98 x 4.45 x 2.72 cm)	
(Aluminum Package)	(2.41 x 5.08 x 3.05 cm)	
Weight (Nylon Package)		
(Aluminum Package)		

¹Not including arc sine error
 Specifications subject to change without notice

Principle of Operation

The CXTLA Series Tilt Sensors use a micro-machined acceleration sensing element with a DC response to measure inclination relative to gravity. The response of the tilt sensor depends on the magnitude of gravity parallel to the sensor element. The output of the tilt sensor will be an offset voltage plus the voltage response proportional to the amount of gravity measured by the sensor.

Using the CXTLA Sensor

The voltage response of the CXTLA is proportional to the tilt angle.

Accurately measuring tilt angle involves solving the equation shown at Figure 1. To solve this equation the Zero Angle Voltage and Sensitivity must be determined prior to use. MEMSIC provides this information on a calibration sheet with its CXTLA products.

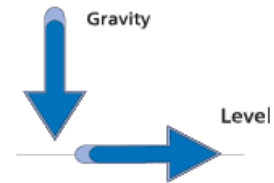
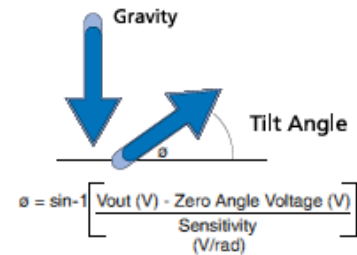

Figure 1
Sensitivity (V/°)



Pin	Color	Function
1	Red	Power
2	Black	Ground
3	White	Roll
4	Yellow	Pitch
5	Green	Temp

Pin Diagram

Ordering Information

Model	Axes	Full Range	Resolution	
CXTLA02	X,Y	± 20°	0.03°	
OPTIONS				
-T	Temperature Sensor Internal			

CALL FACTORY FOR OTHER CONFIGURATIONS

X-ON Electronics

Largest Supplier of Electrical and Electronic Components

Click to view similar products for [Inclinometers](#) category:

Click to view products by [Memsic](#) manufacturer:

Other Similar products are found below :

[02116009-000](#) [ADIS16203CCCZ](#) [MXD6240AU](#) [28036](#) [G-NSDMG-015](#) [G-NSDOG1-006](#) [G-NSDOG2-002](#) [G-NSDOG2-003](#) [NSG-75/DOG2-JXZ-I-STD](#) [CXTA01-T](#) [SCA103T-D05-1](#) [SCA61T-FAHH1G-6](#) [SCL3300-D01-1](#) [SCL3300-D01-10](#) [IIS2ICLXTR](#) [02115002-000](#)