

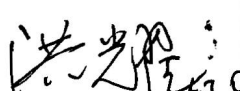
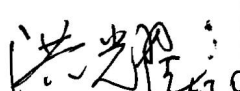

Product Specification

Product Name: T080UC01D01

Customer
Approved by Customer
Approved Date:

Designed By	Checked by	Approved By	
		R&D	QA
 2016.6.30	 2016.6.30	 2016.6.30	 6/30/16

CONTENT

REVISION RECORD	3
1 OVERVIEW	4
2 FEATURES	4
3 GENERAL INFORMATION	4
4 MECHANICAL DRAWING	5
5 MODULE INTERFACE	6
5.1 TFT SIGNAL PIN DESCRIPTION.....	6
5.2 POWER SUPPLY VOLTAGE.....	7
6 ELECTRICAL CHARACTERISTICS	8
6.1 DC ELECTRICAL CHARACTERISTICS.....	8
6.2 AC ELECTRICAL CHARACTERISTICS.....	10
7 POWER ON/OFF SEQUENCE	14
8 OPTICAL CHARACTERISTICS	15
9 RELIABILITY TEST CRITERIA	18
10 PACKAGE SPECIFICATION	19
11 ILLUSTRATION OF PRODUCT NAME	20
12 PRECAUTIONS FOR OPERATION AND STORAGE	20
12.1 PRECAUTIONS FOR OPERATION.....	21
12.2 SOLDERING.....	21
12.3 PRECAUTIONS FOR STORAGE.....	21
12.4 WARRANTY PERIOD.....	21

1 Overview

The specifications is a transmissive type color active matrix liquid crystal display (LCD) which uses amorphous thin film transistor (TFT) as switching devices. This product is composed of a TFT LCD panel, driver IC, FPC, and a backlight unit.

2 Features

- Panel Size: 8 inch
- Number of Pixels /Resolution: 1024×RGB×600
- Interface: LVDS
- RoHS and Halogen-Free Compliance
- Applications: Multimedia application and other hand application

3 General Information

NO.	ITEM	SPECIFICATION	UNIT
1	Dot Matrix	1024(W)×600(H)	Pixels
2	Dot Pitch	0.1725(W)×0.1656 (H)	mm
3	Active Area	176.64(W)×99.36(H)	mm
4	Module Size	189(W)×114.5(H)×6(T)	mm
5	Viewing Angle	6 O'clock	mm
6	Module Weight	240(MAX)	gram

4 Mechanical Drawing

如本印章非红色, 则表明该文件为非受控版本, 不会受到控制和更新. 请使用受控文件.
受控章
分发号:

Pin Assignment

NO.	SYMBOL
1	VCOM
2	D/D0
3	D/D0
4	NC
5	RESET
6	STRB
7	GND
8	NIN00
9	PN00
10	GND
11	NIN01
12	PN01
13	GND
14	NIN02
15	PN02
16	GND
17	NIN0
18	PN0C
19	GND
20	NIN02
21	PN03
22	GND
23	NC
24	NC
25	GND
26	NC
27	NC
28	SEIB
29	AVDD
30	GND
31	NC
32	NC
33	SELR
34	LEPN
35	VGH
36	NC
37	NC
38	VGH
39	NC
40	Bist

NOTES:

1. Display Type: 8" a-Si TFT;
2. Backlight: 21-chips LED, 3 series 7 multiple;
3. View Direction: 6 o'clock;
4. Viewing Angle (U/D/L/R): 70/75/75/75 (Typ);
5. Connector: LCM F32D-147Y-21040/ BLU BHSR-02VS-1;
6. Operate Temp: -30°C~85°C
7. Storage Temp: -40°C~90°C;
8. R&S Compliant.

Customer Approval

Part Name	Module Ass'y
Project Code	7800040
Part No.	7800040-MA1-A

Date 2015.08.12 **Rev.** 05 **Unit** mm **Sheet** 1/1

CHK' D BY DES' D BY CHK' D BY APPROVED

Signature

Pin Assignment

NO.	SYMBOL
1	VCOM
2	D/D0
3	D/D0
4	NC
5	RESET
6	STRB
7	GND
8	NIN00
9	PN00
10	GND
11	NIN01
12	PN01
13	GND
14	NIN02
15	PN02
16	GND
17	NIN0
18	PN0C
19	GND
20	NIN02
21	PN03
22	GND
23	NC
24	NC
25	GND
26	NC
27	NC
28	SEIB
29	AVDD
30	GND
31	NC
32	NC
33	SELR
34	LEPN
35	VGH
36	NC
37	NC
38	VGH
39	NC
40	Bist

4	2015.08.07	Modify the outline.	Rev.	Date	Note
5	2015.08.12	Modify the tolerance, wire length and pin assignment, add the insulating tape.	1	2015.07.14	Primary
			2	2015.07.31	Modify the backlight and FOG.
			3	2015.08.04	Modify the bezel opening area.

5 Module Interface

5.1 TFT Signal PIN Description

PIN No.	Symbol	Description	Remarks
1	VCOM	Common voltage	
2	DVDD	Digital power	
3	DVDD	Digital power	
4	NC	Not connect	
5	RESET	Global reset pin. Active low to enter reset state.	
6	STBYB	Standby mode ,normally pull high	
7	GND	Ground	
8	NIND0	Negative LVDS differential data input	
9	PIND0	Positive LVDS differential data input	
10	GND	Ground	
11	NIND1	Negative LVDS differential data input	
12	PIND1	Positive LVDS differential data input	
13	GND	Ground	
14	NIND2	Negative LVDS differential data input	
15	PIND2	Positive LVDS differential data input	
16	GND	Ground	
17	NINC	Negative LVDS differential clock input	
18	PINC	Positive LVDS differential clock input	
19	GND	Ground	
20	NIND3	Negative LVDS differential data input	
21	PIND3	Positive LVDS differential data input	
22	GND	Ground	
23	NC	Not connect	
24	NC	Not connect	
25	GND	Ground	
26	NC	Not connect	
27	NC	Not connect	
28	SELB	LVDS input data is 8 bits, SELB set to low	
29	AVDD	Power for Analog Circuit	
30	GND	Ground	
31	NC	Not connect	
32	NC	Not connect	
33	SHLR	Horizontal inversion	Note1
34	UPDN	Vertical inversion	Note1
35	VGL	Negative power for TFT	
36	NC	Not connect	
37	NC	Not connect	
38	VGH	Positive power for TFT	
39	NC	Not connect	
40	Bist	Normal operation/BIST pattern select. Normally pull low. When BIST=H: BIST. (CLK input is not needed.) When BIST=L: Normal operation. (Default)	System without the need to signal

Signal Connector Type

Item	Description
Manufacturer/Type	AORORA:F32D-1A7Y-21040

Note1: UPDN and SHLR control function

SHLR	UPDN	Data shifting
DVDD	GND	Left→Right · Up→Down(default)
GND	GND	Right→Left · Up→Down
DVDD	DVDD	Left→Right · Down→Up
GND	DVDD	Right→Left · Down→Up

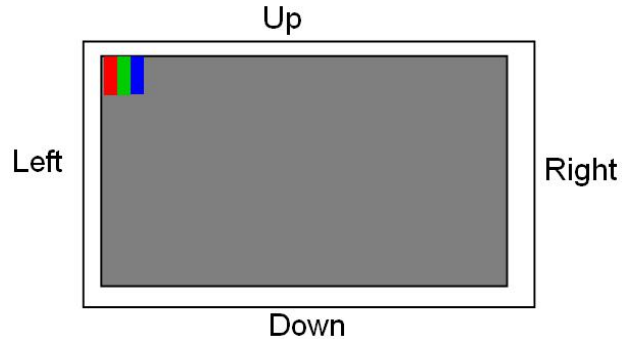

5.2 Power Supply Voltage

Item	Item	Typ.	Max.	Unit
Avdd	(10.85)	(11)	(11.15)	V
Vcom	(3.15)	(3.35)	(3.55)	V
VGH	(19)	(20)	(21)	V
VGL	(-7.8)	(-6.8)	(-5.8)	V

LED Connector Name / Designation

Item	Description
Manufacturer / Type	JST/BHSR-02VS-1
Mating Receptacle / Type (Reference)	JST/SMO2B-BHSS-1 or Compatible

LED Connector Pin Assignment

Pin No.	Symbol	Description	Remarks
1	A	Remarks	-
2	K	Cathode	-

LED Connector

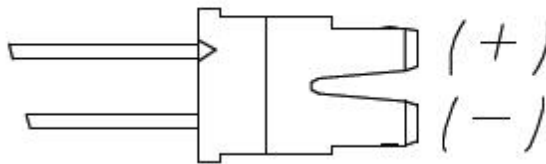

Note (1) The LED life time define as the estimated time to 50% degradation of initial luminous.

Note (2) Operating temperature 25°C, humidity 55%RH.

Note (3) A higher LED power supply voltage will result in better power efficiency. Keep the V_LED between 2.9V and 3.5V is strongly recommended.

LED Rush Current Measure Condition

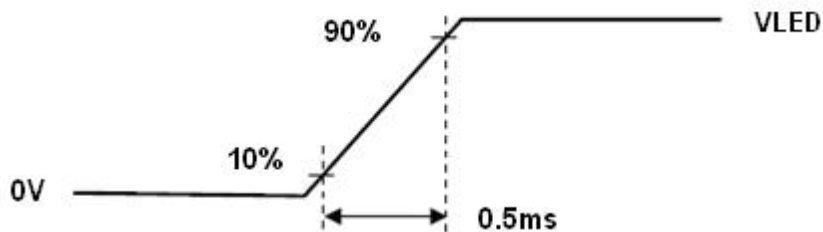

6 Electrical Characteristics

6.1 DC Electrical Characteristics

Item	Symbol	Min.	Typ.	Max.	Unit	Note
Digital Supply Voltage	Dvdd	(3.0)	(3.3)	(3.6)	V	(1), (2)
Logic Input Signal Voltage	Vsignal	(3.0)	-	(3.6)	V	
Operating Temperature	TOP	(-30)		(85)	°C	(3), (4),
Storage Temperature	TST	(-40)		(90)	°C	(5), (6)

Note (1) Permanent damage may occur to the LCD module if beyond this specification. Functional operation should be restricted to the conditions described under normal operating conditions.

Note (2) Operating temperature 25°C , humidity 55%RH.

Note (3) (T<=40°C) Note static electricity. Maximum wet bulb temperature at 39°C or less. (T>40°C) No condensation

Note (4) There is a possibility of causing deterioration in the irregularity and others of the screen and the display fineness though the liquid crystal module doesn't arrive at destruction when using it at 85~90°C or -40~-30°C.

Note (5) There is a possibility of causing the fineness deterioration by the prolonged use in the (high temperature) humidity environment (60%RH or more).

Note (6) In the operating temperature item, the low temperature side is the ambient temperature regulations. The high temperature side is the panel surface temperature regulations.

Note (7) half-sine; Frequency: 8Hz ~ 33Hz; Stroke: 1.3mm; Sweep: 2.9G 33.3Hz ~ 400Hz X,Z Cycle : 15 minutes; 2 hrs for each direction of X,Z ; 4 hours for Y direction

Note (8) 6ms, half sine wave, three times for X, Y, Z axis.

Input Power Specifications

Parameter	Symbol	Min.	Typ.	Max.	Unit	Note
System Power Supply						
LCD Drive Voltage (Logic)	DVDD	(3.0)	(3.3)	(3.6)	V	2,4
VDD Current	IDD	-	-	(0.06)	A	3,4
VDD Power Consumption	PDD	-	-	(0.23)	W	
Black Pattern	IRush	-	-	(1.5)	A	1,4,5
Allowable Logic/LCD Drive Ripple Voltage	V _{VDD-RP}	-	-	(200)	mV	4
LED Power Supply						
LED Input Voltage	VLED	(8.4)	(9.6)	(10.2)	V	4,6
LED Power Consumption	PLED	-	-	(4.3)	W	4,6
LED Forward Voltage	V _F	(2.8)	(3.2)	(3.4)	V	4
LED Forward Current	I _F	-	(60)	-	mA	
LED Life Time	LT	30,000	-	-	Hours	4,7

Note (1) Measure Condition

VDD Rising Time

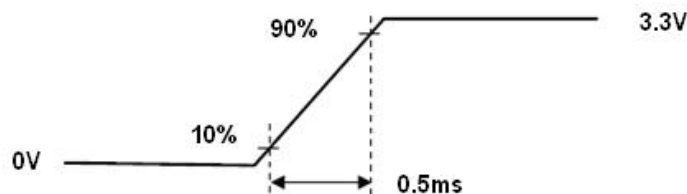

Note (2) VDD Power Dip Condition

$V_{TH} < V_{DDT} V_{min}$, $t_d < 10ms$ (a time of the voltage return to normal), our panel can revive automatically.

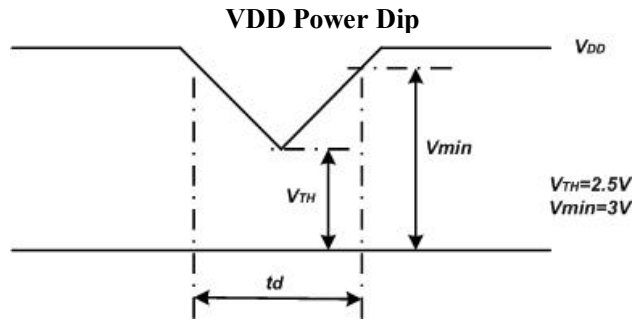

Note (3) Frame Rate=60Hz, VDD=3.3V, DC Current.

Note (4) Operating temperature 25°C, humidity 55%RH.

Note (5) The reference measurement circuit of rush current.

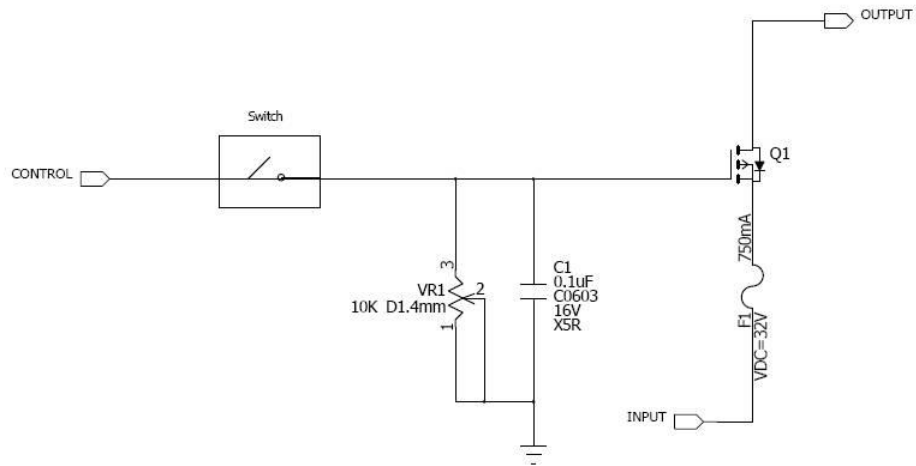

Note (6) Definition of V_{LED} and P_{LED}

$$V_{LED} = V_F \times 3, P_{LED} = V_{LED} \times I_F \times 7$$

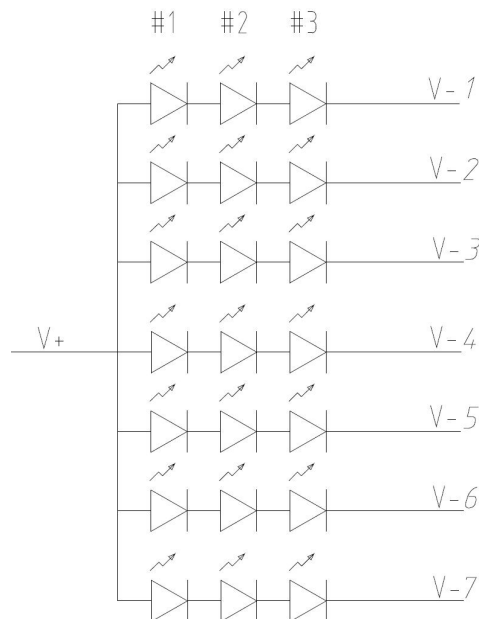

Note (7) The LED life time define as the estimated time to 50% degradation of initial luminous.

6.2 AC Electrical Characteristics

6.2.1 Signal Electrical Characteristics For LVDS Receiver

The built-in LVDS receiver is compatible with (ANSI/TIA/TIA-644) standard.

LVDS Receiver Electrical Characteristics

Parameter	Symbol	Min.	Typ.	Max.	Unit	Conditions
Differential Input High Threshold	Vth	-	-	(+100)	mV	VCM=+1.2V
Differential Input Low Threshold	Vtl	(-100)	-	-	mV	VCM=+1.2V
Magnitude Differential Input Voltage	VID	(200)	-	(600)	mV	-
Common Mode Voltage	VCM	(1.0)	(1.2)	(1.4)	V	Vth- Vtl =200mA
Common Mode Voltage Offset	Δ VCM	(-50)	-	(+50)	mV	Vth- Vtl =200mA

Note (1) Input signals shall be low or Hi- resistance state when VDD is off

Note (2) All electrical characteristics for LVDS signal are defined and shall be measured at the interface connector of LCD.

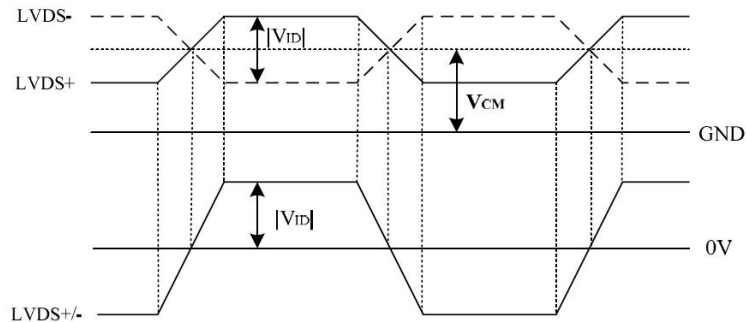

Measurement System

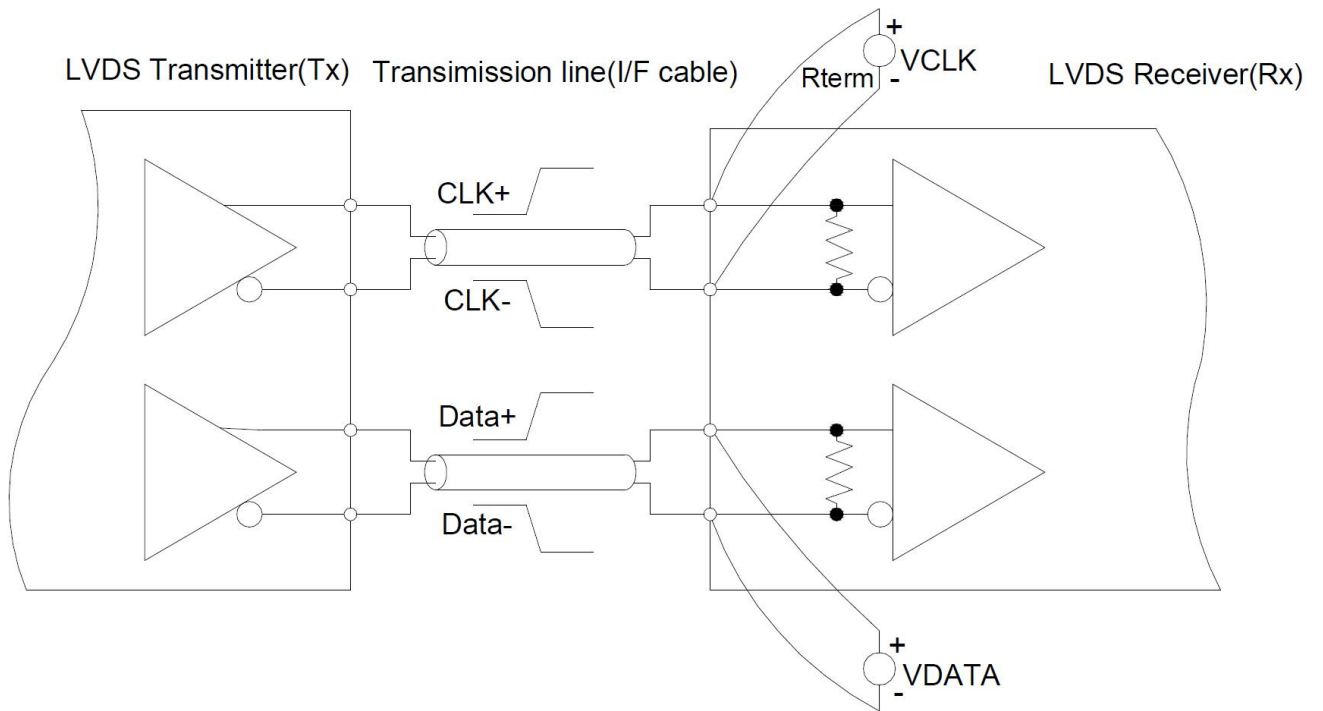

Data Mapping
Single 6 bit LVDS input

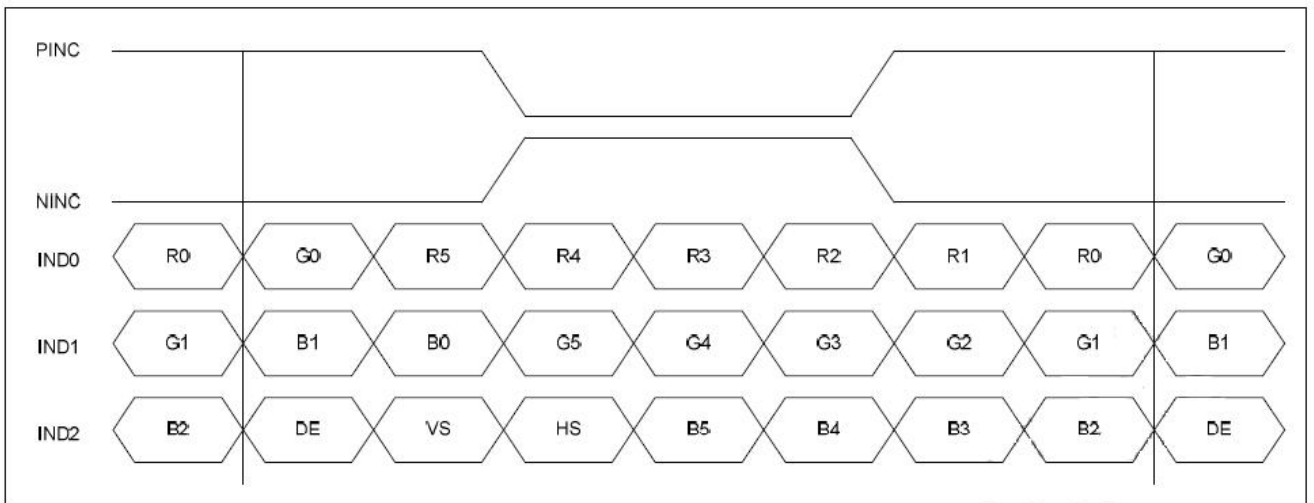

Single 8 bit LVDS input

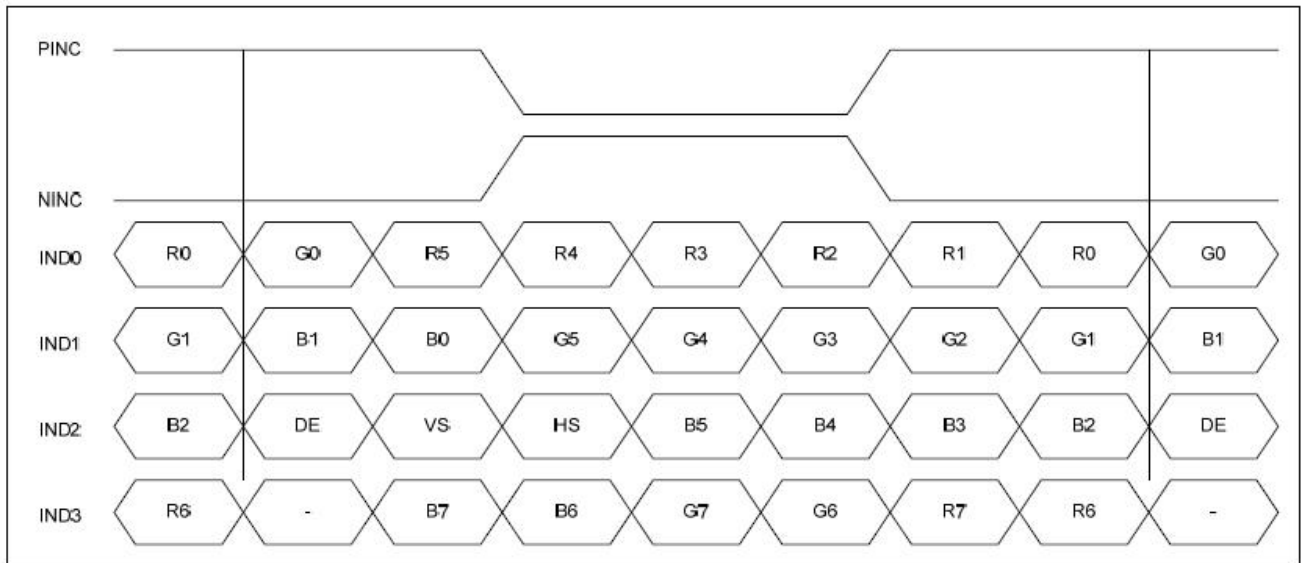

6.2.2 LVDS Receiver Internal Circuit

Figure shows the internal block diagram of the LVDS receiver. This LCD module equips termination resistors for LVDS link..

LVDS Receiver Internal Circuit(6bit)

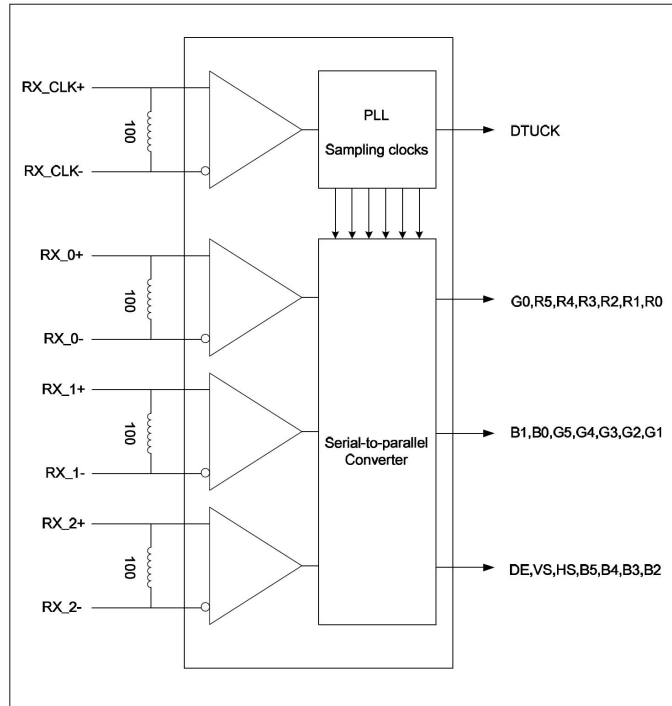

8bit

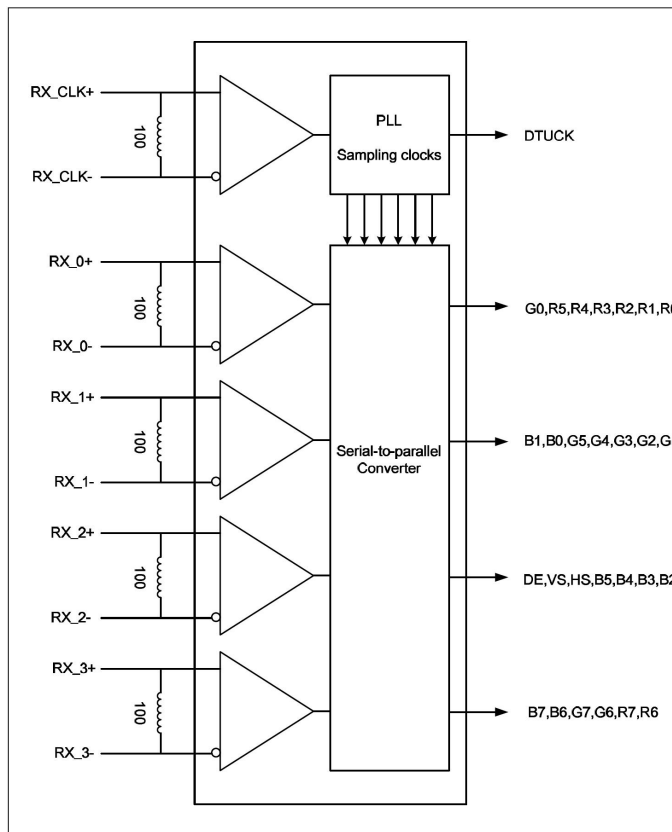

6.2.3 Interface Timings

Parameter	Symbol	Min.	Typ.	Max.	Unit
LVDS Clock Frequency	f_{dck}	(45)	(51.2)	(57)	MHz
H Total Time	T_{hp}	(1,324)	(1,344)	(1,364)	Clocks

H Active Time	HA	(1,024)	(1,024)	(1,024)	Clocks
H Blanking Time	TH _{Blank}	(300)	(320)	(340)	Clocks
V Total Time	T _{vp}	(625)	(635)	(645)	Lines
V Active Time	VA	(600)	(600)	(600)	Lines
V Blanking Time	TV _{Blank}	(25)	(35)	(45)	Clocks
Frame Rate	F _v	(55)	(60)	(65)	Hz

7 Power ON/OFF Sequence

Interface signals are also shown in the chart. Signals from any system shall be Hi- resistance state or low level when VDD voltage is off.

Power Sequence

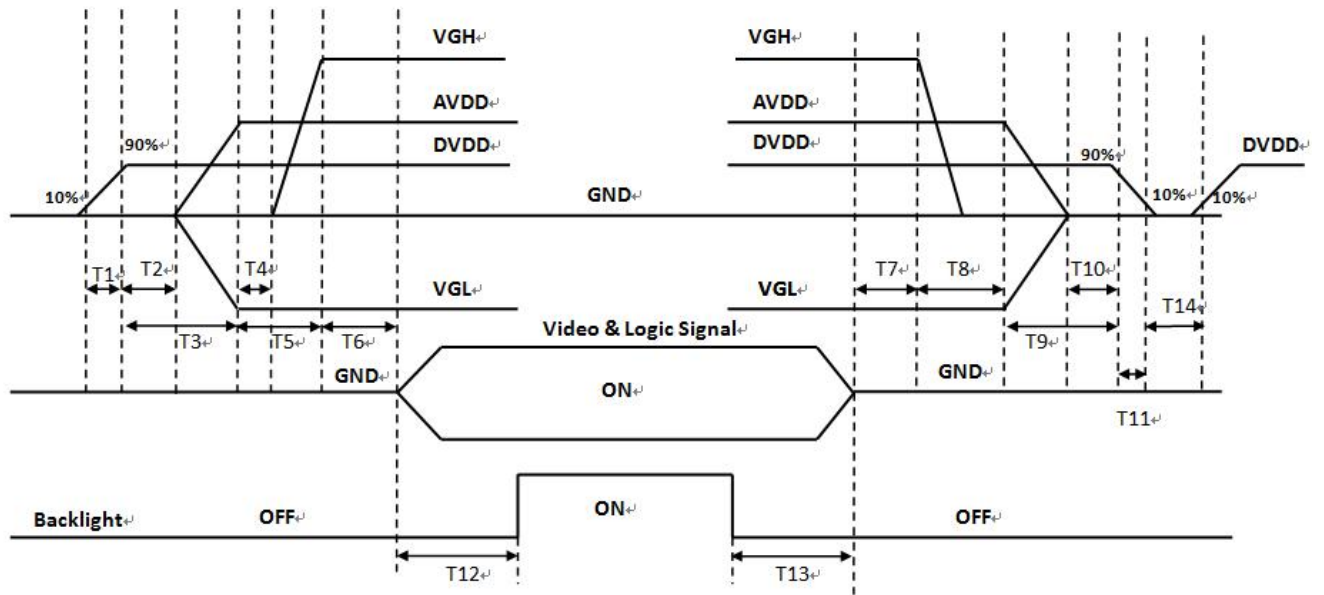

Power On: DVDD--AVDD/VGL—VGH--Video & Logic Signal--Backlight
 Power Off: Backlight-- Video & Logic Signal—VGH-- AVDD/VGL-- DVDD

Power Sequencing Requirements

Parameter	Symbol	Min.	Typ.	Max.	Unit
DVDD Rising Time from 10% to 90%	T1	0.5	-	10	ms
DVDD Good to AVDD/VGL On	T2	0	-	-	ms
DVDD Good to AVDD/VGL Good	T3	20	-	-	ms
AVDD/VGL Good to VGH On	T4	0	-	-	ms
AVDD/VGL Good to VGH Good	T5	10	-	-	ms
VGH Good to Signal Valid	T6	0	-	10	ms
Signal Disable to VGH Down	T7	0	-	50	ms
VGH Down to AVDD/VGL Down	T8	0	-	50	ms
AVDD/VGL Down to DVDD Down	T9	0	-	-	ms
AVDD/VGL Off to DVDD Down	T10	0	-	-	ms
DVDD Falling Time	T11	0	-	10	ms
Signal Valid to Backlight Power On	T12	200	-	-	ms
Backlight Power Off to Signal disable	T13	200	-	-	ms
Power Off Time	T14	500	-	-	ms

8 Optical characteristics

The optical characteristics are measured under stable conditions as following notes

Item	Conditions		Min.	Typ.	Max.	Unit	Note
Viewing Angle (CR>10) ☆	Horizontal	θ_{x+}	(65)	(75)	-	degree	(1),(2),(3)
		θ_{x-}	(65)	(75)	-		
	Vertical	θ_{y+}	(60)	(70)	-		
		θ_{y-}	(65)	(75)	-		
Contrast Ratio ☆	Center		(600)	(800)	-	-	(1),(2),(4) $\theta_x=\theta_y=0^\circ$
Response Time ☆	Rising + Falling		-	(16)	(25)	ms	(1),(2),(5) $\theta_x=\theta_y=0^\circ$
Color Chromaticity (CIE1931) ☆	Red	x	TBD	TBD	TBD	-	(1),(2),(3) $\theta_x=\theta_y=0^\circ$
	Red	y		TBD		-	
	Green	x		TBD		-	
	Green	y		TBD		-	
	Blue	x		TBD		-	
	Blue	y		TBD		-	
	White	x	Typ. (-0.04)	(0.315)	Typ. (+0.04)	-	
	White	y		(0.335)		-	
NTSC	-		(67)	(72)	-	%	(1),(2),(3) $\theta_x=\theta_y=0^\circ$
White Luminance	Center Point		(550)	(670)	-	cd/m ²	(1),(2),(6) $\theta_x=\theta_y=0^\circ$
Luminance Uniformity	9 Points		(75)	(80)	-	%	(1),(2),(6) $\theta_x=\theta_y=0^\circ$

Note (1). Measurement Setup:

The LCD module should be stabilized at given temperature(25°C) for 15 minutes to Avoid abrupt temperature change during measuring. In order to stabilize the luminance, the measurement should be executed after lighting backlight for 15 minutes in a windless room.

Measurement Setup

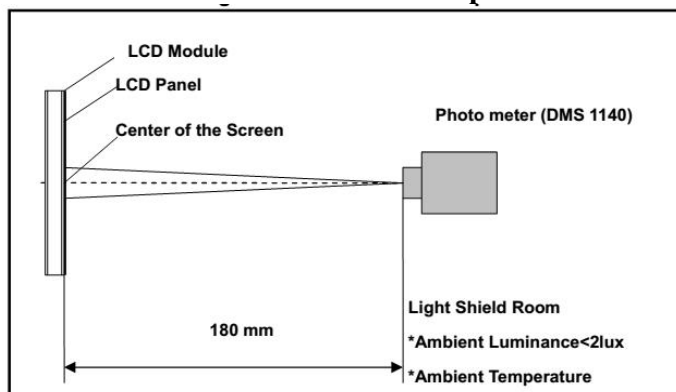

Note (2). The LED input parameter setting as:

I_LED: 420mA

Note (3). Definition of Viewing Angle

Definition of Viewing Angle

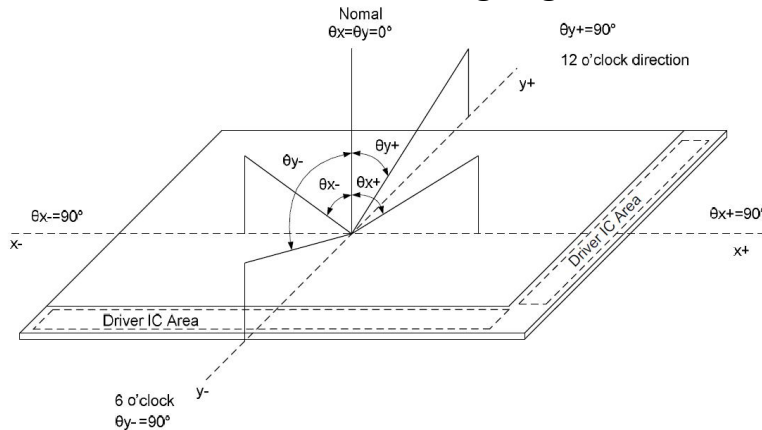

Note (4). Definition Of Contrast Ratio (CR)

The contrast ratio can be calculated by the following expression

$$\text{Contrast Ratio (CR)} = L_{255} / L_0$$

L_{255} : Luminance of gray level 255, L_0 : Luminance of gray level 0

Note (5). Definition Of Response Time (TR, TF)

Definition of Response Time

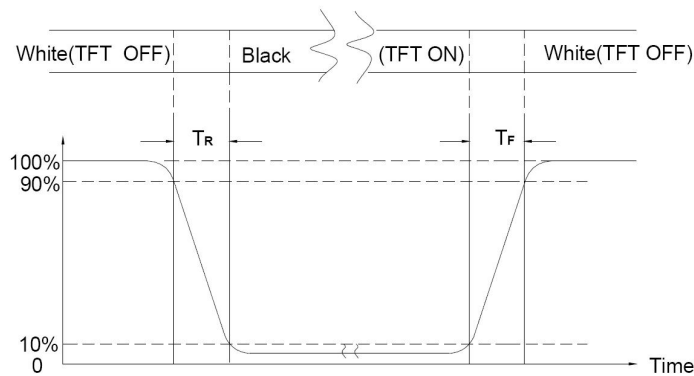

Note (6). Definition of Luminance Uniformity (Ref.: Active Area)

Measure the luminance of gray level 255 at 9 points.

$$\text{Luminance Uniformity} = \text{Min.}(L_1, L_2, \dots, L_9) / \text{Max.}(L_1, L_2, \dots, L_9)$$

H—Active Area Width, V—Active Area Height, L—Luminance

Measurement Locations

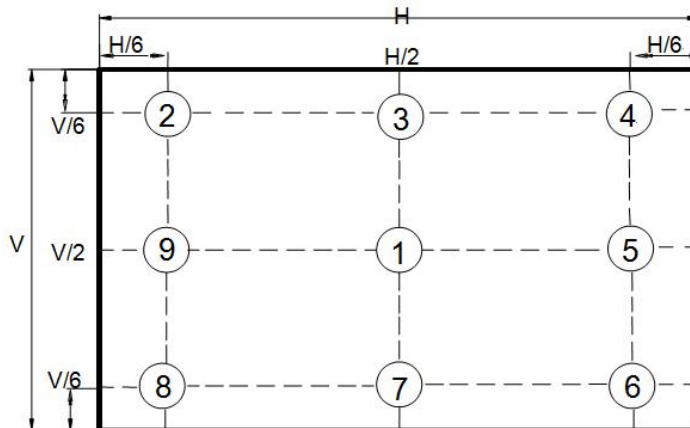

9 Reliability Test Criteria

Item		Package	Test Conditions		Note
High Temperature Operating Test		Module	85°C, 500 hours		(1),(2),(3),(4)
Low Temperature Operating Test		Module	-30°C, 500 hours		(1),(2),(3),(4)
High Temperature Storage Test		Module	90°C, 500 hours		(1),(2),(4)
Low Temperature Storage Test		Module	-40°C, 500 hours		(1),(2),(4)
High Temperature/High Humidity Operating Test		Module	65°C, 90%RH, 500 hours		(1),(2),(3),(4)
High Temperature/High Humidity Storage Test		Module	65°C, 90%RH, 500 hours		(1),(2),(3),(4)
Thermal Shock Storage		Module	-40°(0.5hr)~85°(0.5hr)C/200cycles;		(1),(2),(3),(4), Meet the system reaches 615cycles
ESD Test	Operating	Module	Contact	±8KV, 150pF(330Ohm)(Class B)	(5)
			Air	±15KV, 150pF(330Ohm)(ClassB)	

Note (1) All the judgments are under room temperature and the sample need to be static more than 2 hours in the room temperature before judge.

Note (2) During measurement, the condensation water or remains shall not be allowed.



Note (3) In operating test, the backlight voltage and current must be in specification.

Note (4) There is no display function issue occurred, all the cosmetic specification is judged before the reliability stress.

Note (5) In case of malfunction defect caused by ESD damage. If it would be recovered to normal state after placing for a while, it would be judge as pass.

10 Package Specification

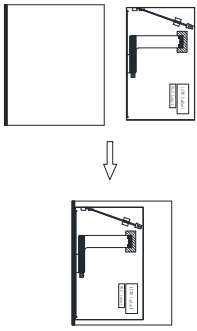
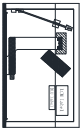
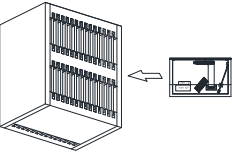
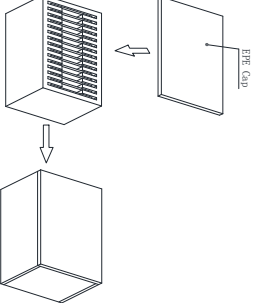
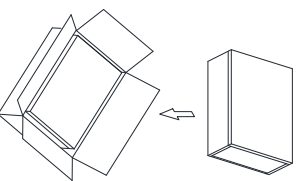
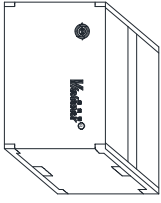
Packing Process (1) ~ (6)

<p>(1) Part No. : T800040-MA1-A 1pcs LCM+1pcs PE bag.</p> 	<p>(2) Put the LCM in the PE bag, the mouth sealed with adhesive tape.</p> 	<p>(3) FPC face down, put the LCM in the EPE card slot, total 28PCS, 28pcs/inner carton.</p> 	<p>(4) Cover EPE cap.</p> 
<p>(5) Put the EPE box in the inner carton.</p> 	<p>(6) Package QTY: LCM 28pcs/master carton.</p> 	<p>1、 The inner carton and master carton must be sealed with adhesive tape. 2、 If there is a gap please add the EPE. 3、 If the customer has special needs with the RoHS marking, the inner carton and master carton need adhesive new RoHS marking at .</p>	

11 Illustration of Product Name

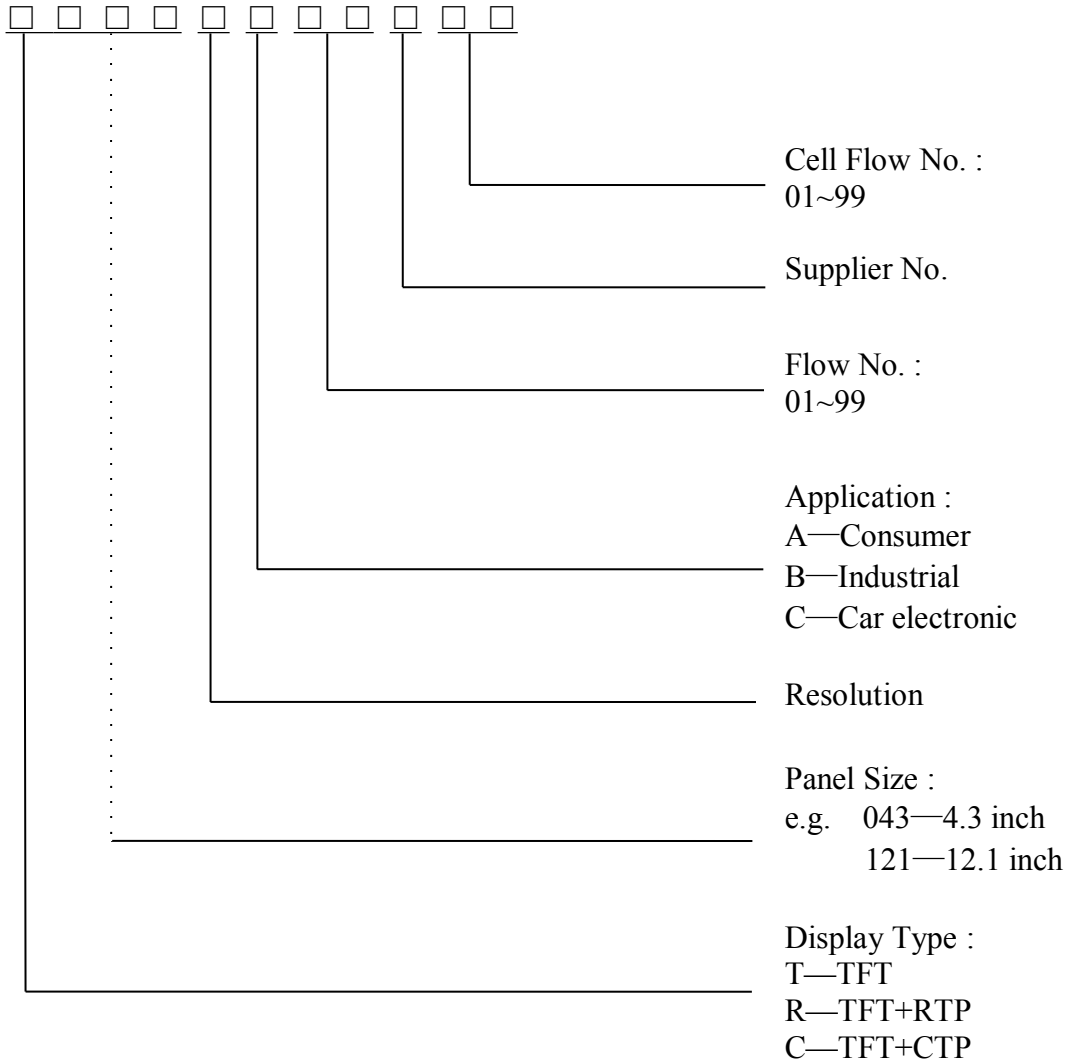

12 Precautions for operation and Storage

12.1 Precautions for Operation

- (1) Since the display panel is made of glass, do not apply any mechanical shock or impact or excessive force to it when installing the module. Any strong mechanical impact due to falling dropping etc. may cause damage (breakage or cracking).
- (2) If the display panel is damaged and the liquid crystal substance inside it leaks out, be sure not to get any in your mouth, if the substance comes into contact with your skin or clothes, promptly wash it off using soap and water.
- (3) The polarizer on the display surface is made of soft material and is easily scratched. Please take most care when handing. When the display surface is contaminated, please wipe it off gently by using moisten soft cloth with isopropyl alcohol, do not use water, ketone or aromatics. If still not completely clear, moisten cloth with isopropyl alcohol or ethyl alcohol solvents.
- (4) When handling the LCD module, please be sure that the body and the tools are properly grounded. And do not touch I/O pins with bare hands or contaminate I/O pins, it will cause disconnection or defective insulation of terminals.
- (5) Do not attempt to disassemble or process the LCD module.
- (6) The LCD Module is coated with a film to protect the display surface. Be care when peeling off this protective film since static electricity may be generated. To reduce the amount of static electricity generated, do not conduct assembly and other work under dry conditions.
- (7) Do not put one product on the other .Otherwise, it may cause the product to bescratched and/or change on cosmetic occur (ex. Newton ring).

12.2 Soldering

- (1) Soldering should be performed only on the I/O terminals.
- (2) Use soldering irons with proper grounding and no leakage.
- (3) Iron: no higher than 300°C and 3~4 sec during soldering.

12.3 Precautions for Storage

- (1) Please store LCD module in a dark place. Avoid exposure to sunlight, the light of fluorescent lamp or any ultraviolet ray.
- (2) Keep the environment temperature between 0°C and 40°C and the relative humidity less than 80%.Avoid high temperature and high humidity.
- (3) Keep the LCD modules stored in the room without acid ,alkali and harmful gas.

12.4 Warranty period

Visionox warrants for a period of 12 months from the shipping date when stored or used under normal condition.

X-ON Electronics

Largest Supplier of Electrical and Electronic Components

Click to view similar products for [TFT Displays & Accessories category](#):

Click to view products by [Visionox manufacturer](#):

Other Similar products are found below :

[OAI-80038AA-2013-A](#) [HDA430T-3G1H](#) [EA CARREDIPTFT02](#) [NL6448BC20-21D](#) [NB7W-KBA04](#) [NB-ATT01](#) [NB5Q-ATT01](#) [NB5Q-KBA04](#) [NB-CN001](#) [NL12880BC20-05](#) [NL8060BC26-35C](#) [TCG104SVLQAPNN-AN20](#) [OAI-80038AA-2008-A](#) [315-U004B15300](#) [UMSH-8596MD-34T \(REV D\)](#) [98-0003-3490-8](#) [1044278](#) [1029309](#) [1060549](#) [DE 127-TU-30/7,5](#) [DE 128-TU-20/7,5](#) [EP-LK007TFTPCAP](#) [FR7.0A00](#) [RC2002A-TIG-CSX](#) [NL6448BC2021C](#) [TX14D23VM5BAA](#) [TCG121WXLRXVNNANX35](#) [EIC-LCD-1080P](#) [T272480C07VR01](#) [1060632](#) [TCG070WVLPAANN-AN50](#) [TCG035QVLPDANN-GN50](#) [1060630](#) [RFE430V-AIW-DNG](#) [T-55619GD065J-LW-ABN](#) [NHD-1.8-128160EF-SSXN-FT](#) [TCG104SVLPEANN-AN30](#) [NL6448BC33-70](#) [NL192108BC18-06F](#) [NLB150XG02L-01](#) [NL6448BC20-30D](#) [NL10276BC16-06](#) [NL192108AC10-01D](#) [NL6448AC18-08F](#) [NL6448BC20-30F](#) [NL12880BC20-05BD](#) [NL12880BC20-05D](#) [NL8060BC26-35BA](#) [NL10276BC30-34D](#) [NL6448BC26-26D](#)