

Amphenol Corporation
Amphenol Aerospace
Amphenol Industrial Operations
40-60 Delaware Avenue
Sidney, NY 13838-1395
Phone: 607-563-5011
1-800-678-0141
Fax: 607-563-5157
Web: www.amphenol-aerospace.com
Web: www.amphenol-industrial.com

SALES OFFICES

Amphenol Corporation
Amphenol Aerospace
Amphenol Industrial Operations
23276 South Pointe Drive
Suite 113
Laguna Hills, CA 92653
Phone: 949-855-4454
1-800-678-0141
Fax: 949-855-9115

Amphenol Corporation
Amphenol Aerospace
Amphenol Industrial Operations
7506 East Independence Blvd.
Charlotte, NC 28227
Phone: 704-531-9053
1-800-678-0141
Fax: 704-531-9054

Amphenol Corporation
Amphenol Aerospace
Amphenol Industrial Operations
2010 Corporate Ridge
McLean, VA 22101
Phone: 1-800-678-0141

Amphenol Industrial Operations
Amphenol Power Solutions
34190 Riveria Drive
Fraser, MI 48026
Phone: 586-294-7400
Fax: 586-294-7402
www.radsok.com

For information on International Products, a North American office can be contacted:
Phone: 978-532-8800
Fax: 978-532-6800

Amphenol PCD
2 Technology Drive
Peabody, MA 01960
Phone: 978-532-8800
Fax: 978-532-6800
Email: pcddsales@pcdinc.com

Amphenol Canada
20 Melford Drive
Scarborough, ON M1B 2X6
Canada
Phone: 416-291-4401
Fax: 416-292-0647

DISTRIBUTORS
Corporate Headquarters
ARROW ELECTRONICS
7459 S. Lima Street
Englewood, CO 80112-5816
Phone: 800-388-2277
Fax: 800-562-3542

AVNET EMG
11333 Pagemill Road
Dallas, TX 75243
Phone: 800-332-8638
Fax: 214-553-2168

POWELL ELECTRONICS
4848 S. Island Ave.,
Philadelphia, PA 19153
Phone: 800-235-7880
Fax: 215-937-4655

TTI INC.
2441 Northeast Parkway
Fort Worth, TX 76106
Phone: 800-225-5884
Fax: 817-740-9494

**SMALL DISADVANTAGED/
MINORITY DISTRIBUTORS**
CHEROKEE NATION DISTRIBUTORS

Highway 51 West
P.O. Box 1130
Stilwell, OK 74960
Phone: 918-696-2777
Fax: 918-696-3129

JRH ELECTRONICS INC.
2002 E. Lincoln Drive West
Route 73, P.O. Box 264
Marlton, NJ 08053
Phone: 800-467-9309
Fax: 609-988-8728

INTERNATIONAL

Latin America
ARGENTINA
Amphenol Argentina
Avenida Callao 930
2nd floor Office B Plaza
C1023AAP Buenos Aires, Argentina
Phone: (54 11) 48 15 68 86
Fax: (54 11) 48 14 57 79
E-mail: vendas@amphenol.com.ar

BRAZIL
Amphenol do Brasil Ltda.
Rua Diogo Moreira 132
CEP 05423-010
Sao Paulo - SP, Brazil
Phone: (55-11) 3815.1003
Fax: (55-11) 3815.1629
E-mail: vendas@amphenol.com.br

MEXICO
Amphenol Mexico
Prolongacion Reforma 61-6 B2
Col. Paseo de las Lomas
C.P. 01330 Mexico D.F., Mexico
Phone: (52-55) 5258.9984
Fax: (52-55) 5081.6890
E-mail: info@amphenolmexico.com

Europe
AUSTRIA & EASTERN EUROPE
Amphenol Gesellschaft mbH
P.O. Box 63, 3990 DB Houten,
The Netherlands
Phone: 31 30 6358000
Fax: 31 30 6377899
E-mail: info@amphenol-nl.com

ENGLAND
Amphenol Limited
Thanet Way, Whitstable
Kent CT5 3JF, United Kingdom
Phone: (44-1-227) 773200
Fax: (44-1-227) 276571
Email: info@amphenol.co.uk

FRANCE
Amphenol Socapex
Promenade de l'Arve, BP29
Thyez 74301 948 Cedex, France
Phone: (33-4) 50892800
Fax: (33-4) 5096-1941
ASF CBV TX

FRANCE
Amphenol-Air LB
29, Voie d'Y Vois
F-00810 Blagny, France
Phone: 33-3-2422-7849
Fax: 33-3-2422-7875

GERMANY
Amphenol-Tuchel Elect. GmbH
August-Haeusser Strasse 10
Postfach 1110
74001 Heilbronn, Germany
Phone: (49-7131) 929 0
Fax: (49-7131) 929 414

GERMANY
Amphenol-Air LB GmbH
Am Kleibahnhof 4
D-66740 Saarlouis, Germany
Phone: (49-6831) 9810-87
Fax: (49-6831) 9810-30

ITALY
Amphenol Italia S.p.A.
Via Barbaiana 5
20020 Lainate (Milano), Italy
Phone: 39-02-932541
Fax: 39-02-93254444
E-mail: info@amphenol-it.com

BENELUX
Amphenol European Sales Operations
Amphenol Benelux BV
P.O. Box 63, 3990 DB Houten
The Netherlands
Phone: 31-30-6358000
Fax: 31-30-6377034
E-mail: info@amphenol-nl.com

SPAIN & PORTUGAL
Amphenol Iberica
Edificio "Burgosol" - Oficina No. 55
c/ Comunidad de Madrid, 35-bis,
28230 Las Rozas, Madrid, Spain
Phone: 34-91-6407303
Fax: 34-91-6407307
E-mail: info@amphenol-it.com

SWITZERLAND
Amphenol Switzerland
P.O. Box 63, 3990 DB Houten
The Netherlands
Phone: 31 30 6358000
Fax: 31 30 6377899
E-mail: info@amphenol-nl.com

Middle East / Africa
ISRAEL
Bar-Tec Ltd.
3 Hagavish St., P.O.B. 279
Kfir-Barkan Bldg., East Indust. Zone
Kfar Sava 44102, Israel
Phone: (972-9) 764.4100
Fax: (972-9) 7674324
E-mail: www.bar-tec.com

SOUTH AFRICA
Amphenol South Africa
30 Impala Road
Chislehurst
Sandton, 2146, South Africa
Tel: (27-11) 783-9517
Fax: (27-11) 783-9519
E-mail: amphenol_africa@csi.com

TURKEY
GESTAS
34630, Besyol - Londra Asfalti
Florya Is Merkezi - Kat. 2
Sefakoy / Istanbul, Turkey
Phone: (90-212) 624.52.29
Fax: (90-212) 599.30.68

Asia / Pacific
AUSTRALIA
Amphenol Australia Pty Ltd
2 Fiveways Blvd.
Melbourne, Victoria 3173
Australia
Phone: 613 8796 8888
Fax: 613 8796 8801
E-mail: info@amphenol.com.au

CHINA
Amphenol China
Room C2, 26/F, Block C
Electronics Science & Tech. Bldg.
2070 Shennan Road
Shenzhen, China 518031
Phone: 86-755-83683575
Fax: 86-755-83683567

HONG KONG
Amphenol East Asia Ltd.
2201 Railway Plaza
39 Chatham Road South
Tsmishatsui, Kowloon, Hong Kong
Phone: 852-2699-2663
Fax: 852-2691-1774

INDIA
Amphenol Interconnect India, Pvt, Ltd.
105 Bhosari Industrial Area
Pune, 411 026, India
Phone: (91-20) 27120 481
Fax: (91-20) 27120 581
E-mail: sales@amphenol-in.com

JAPAN
Amphenol Japan Mii Aero & Industrial
689-1 Iseochi, Ritto-shi
Shiga 520-3044, Japan
Phone: 81-77-553-8501
Fax: 81-77-551-2200

KOREA
Amphenol Daeshin
#558 SoSa, SongNae
Bucheon-City, Kyungki-Do
Korea 420-130
Phone: 82-32-680-3800
Fax: 82-32-673-2507

SINGAPORE
Amphenol East Asia, Ltd.
#25-07, The Concourse
300 Beach Road, Singapore 199555
Phone: 65-2942128
Fax: 65-2943522

TAIWAN
Amphenol Taiwan
No. 116, Lane 956, Zhong Shan Rd.
Taoyuan City, Taiwan, R.O.C. 330
Phone: (886-3) 379-5677
Fax: (886-3) 360-7259

Amphenol® / Pyle® MIL-C-83723, Series III Connectors

MS-102-1

Threaded or Bayonet Connectors for Demanding Environments.
Including High Temperature Capability up to 260°C/500°F.

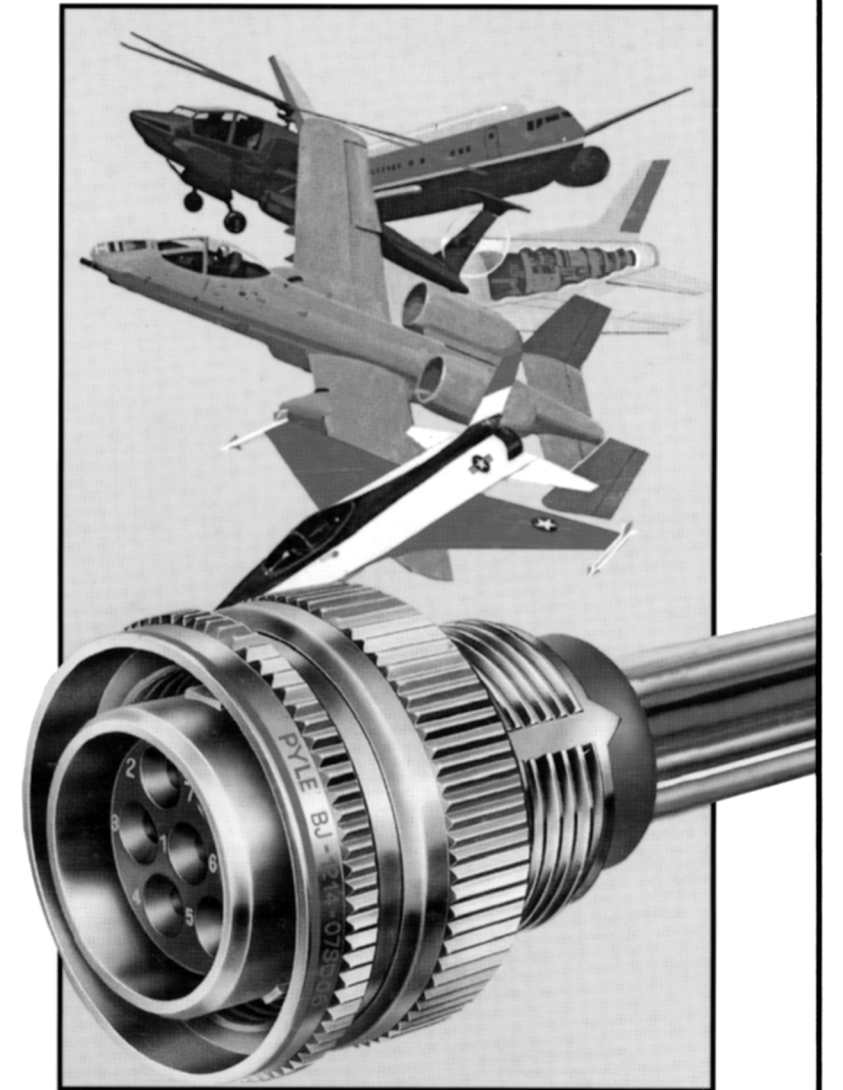

Amphenol

Notice: Specifications are subject to change without notice. Contact your nearest Amphenol Corporation Sales Office for the latest specifications. All statements, information and data given herein are believed to be accurate and reliable but are presented without guarantee, warranty, or responsibility of any kind expressed or implied. Statements or suggestions concerning possible use of our products are made without representation or warranty that any such use is free of patent infringement and are not recommendations to infringe any patent. The user should not assume that all safety measures are indicated or that other measures may not be required. Specifications are typical and may not apply to all connectors.

MIL-C-83723

SERIES III CONNECTORS

MIL-C-83723 SERIES III— THREADED STYLE

- Patented non-decoupling device (torque differential)
- Metal to metal bottoming
- Unique sealing grommet accepts wide range of wire diameters

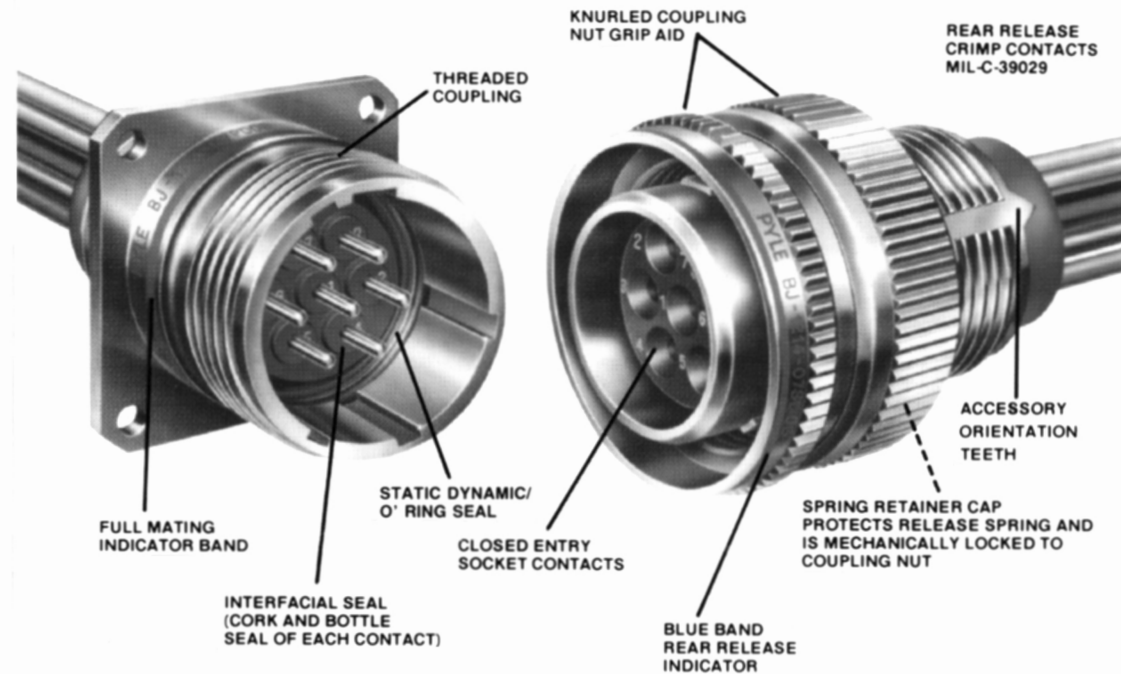

MIL-C-83723 SERIES III— HIGH- TEMPERATURE STYLE

- High temperature materials
- High temperature contacts
- Improved metal to metal bottoming design
- Unique sealing grommet accepts wide range of wire diameters
- Improved 360° accessory orientation teeth provide greater performance under vibration
- Patented non-decoupling device (torque differential)
- Improved shell to shell conductivity with optional grounding spring

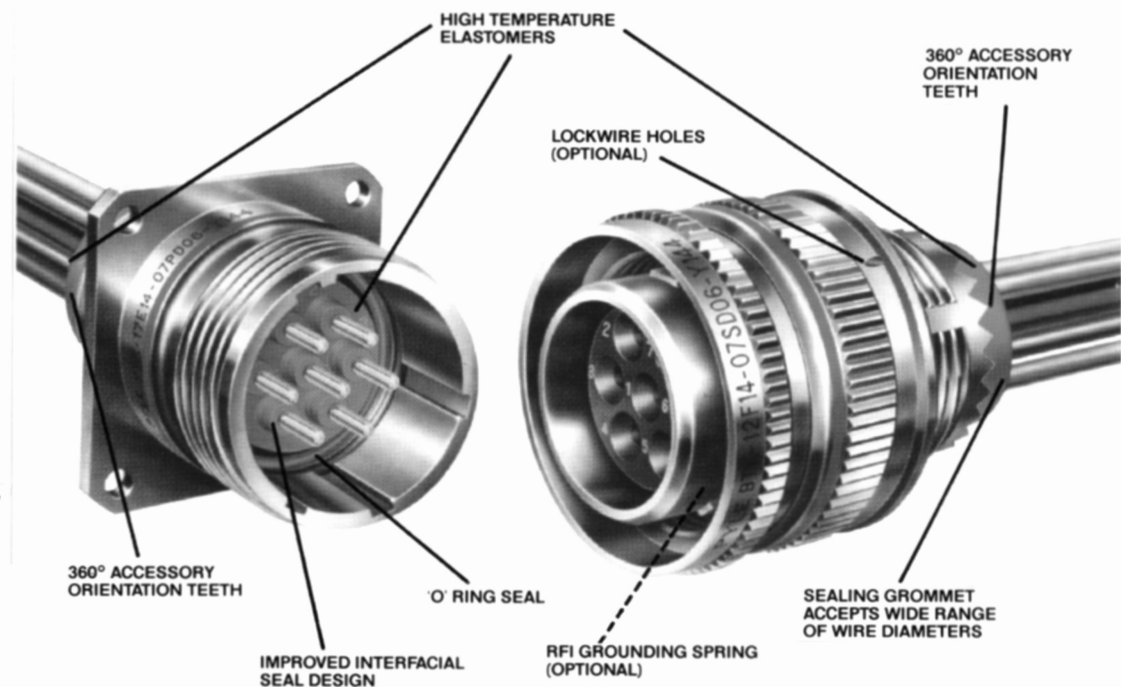

CONTACT INFORMATION—EUROPEAN SPECIFICATION

Standard Power Contacts

CONTACT SIZE	CONTACT PIN PART NUMBER		COLOR BANDS			SOCKET PART NUMBER	
	PYLE	EN3155	1st	2nd	DOT	PYLE	EN3155
20	BA-4020-36LD-Y165	EN3155-002M2020	Red	Red	—	BA-4120-36LD-Y165	EN3155-003F2020
20/18*	BA-402018-36LD-Y165	EN3155-002M2018	Red	Violet	—	BA-412018-36LD-Y165	EN3155-003F2018
16	BA-4016-36LD-Y165	EN3155-002M1616	Blue	Blue	—	BA-4116-36LD-Y165	EN3155-003F1616
12	BA-4012-36LD-Y165	EN3155-002M1212	Yellow	Yellow	—	BA-4112-36LD-Y165	EN3155-003F1212

High Temperature Contacts

CONTACT SIZE	PIN PART NUMBER			COLOR BANDS		
	PYLE	ESC30	EN3155	1st	2nd	DOT
20	BA-4020-50LD	ESC30-P20BC	EN3155-004M2020	Red	Red	White
20/18*	BA-402018-50LD	—	EN3155-004M2018	Red	Violet	White
16	BA-4016-50LD	ESC30-P16BC	EN3155-004M1616	Blue	Blue	White
12	BA-4012-50LD	ESC30-P12BC	EN3155-004M1212	Yellow	Yellow	White

CONTACT SIZE	SOCKET PART NUMBER			COLOR BANDS		
	PYLE	ESC30	EN3155	1st	2nd	DOT
20	BA-4120-50LD	ESC30-S20BC	EN3155-005M2020	Red	Red	White
20/18*	BA-412018-50LD	—	EN3155-005M2018	Red	Violet	White
16	BA-4116-50LD	ESC30-S16BC	EN3155-005M1616	Blue	Blue	White
12	BA-4112-50LD	ESC30-S12BC	EN3155-005M1212	Yellow	Yellow	White

Thermocouple Contacts

CONTACT SIZE	MATERIAL	PIN PART NUMBER		COLOR BANDS			SOCKET PART NUMBER	
		PYLE	ESC30	1st	2nd	DOT	PYLE	ESC30
20	Chromel	BT-4020-10P-Y165	ESC30-P20NC	Red	Red	Yellow	BT-4120-10P-Y165	ESC30-S20NC
20	Alumel	BT-4020-10R-Y165	ESC30-P20NA	Red	Red	Black	BT-4120-10R-Y165	ESC30-S20NA
20/18*	Chromel	BT-402018-10P-Y165	—	Red	Violet	Yellow	BT-412018-10P-Y165	—
20/18*	Alumel	BT-402018-10R-Y165	—	Red	Violet	Black	BT-412018-10R-Y165	—
16	Chromel	BT-4016-10P-Y165	ESC30-P16NC	Blue	Blue	Yellow	BT-4116-10P-Y165	ESC30-S16NC
16	Alumel	BT-4016-10R-Y165	ESC30-P16NA	Blue	Blue	Black	BT-4116-10R-Y165	ESC30-S16NA

* #20 contacts with #18 crimpwell

High Temperature Seal Plug

CONTACT SIZE	PYLE	COLOR BAND
20	BT-4020-60P	RED
16	BT-4016-60P	BLUE
12	BT-4012-60P	YELLOW

Band 1: Color-contact size

Band 2: Color-AWG Wire

Dot: Identification marking — High Temperature/Thermal couple contacts

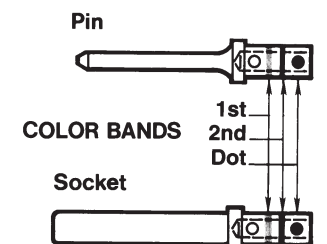

CONTACT INFORMATION

SHIELDED CONTACTS

CONTACT SIZE	PIN	CABLE ACCOMMODATION	SOCKET
#8 Twinax	BA-46T08-LD	M17/176-00002	BA-47T08-LD
#8 Twinax	BA-46TA08-LD	PAN 6421 or JN1060ZB002	BA-47TA08-LD

THERMOCOUPLE CONTACTS

CONTACT SIZE	MATERIAL	PIN PART NUMBER	SOCKET NUMBER
20	Chromel	BT-4020-10P	BT-4120-10P
20	Alumel	BT-4020-10R	BT-4120-10R
16	Chromel	BT-4016-10P	BT-4116-10P
16	Alumel	BT-4016-10R	BT-4116-10R

CONTACT SIZE	MATERIAL	PIN COLOR BANDS		
		1st	2nd	3rd
20	Chromel	Brown	Orange	Green
20	Alumel	Brown	Orange	Yellow
16	Chromel	Green	Brown	Violet
16	Alumel	Green	Brown	Blue

CONTACT SIZE	MATERIAL	SOCKET COLOR BANDS		
		1st	2nd	3rd
20	Chromel	Brown	Yellow	Brown
20	Alumel	Brown	Yellow	Black
16	Chromel	Green	Red	Red
16	Alumel	Green	Red	Brown

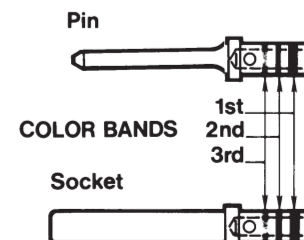

Standard and High Temperature Wire Sealing Diameters/Stripping Length

CONTACT SIZE	WIRE SIZE (AWG)	FINISHED WIRE OUTSIDE				STRIPPING LENGTH	
		MINIMUM		MAXIMUM		MINIMUM INCHES	MAXIMUM INCHES
		INCH	METRIC	INCH	METRIC		
20	24, 22, 20	.033	.085	.083	2.1	.140	.202
16	20, 18, 16	.047	1.2	.106	2.7	.218	.280
12	14, 12	.075	1.9	.157	4	.218	.280

MIL-C-83723 SERIES III

Pyle-National has a long history as a quality supplier of connectors for demanding environments. Proven technology and traditional Pyle attention to design details are incorporated into all styles and classes of the Pyle-National MIL-C-83723 Series III connectors.

In our M83723/95, 96 Series (featured on page 2), Pyle offers the user a major performance advantage through a unique threaded coupling mechanism that features a greater resistance to decoupling than to coupling. This device eliminates the need for safety wiring and tends to couple during vibration – thus offering the user added assurance and a margin of safety.

MIL-C-83723 SERIES III-HIGH TEMPERATURE

Using MIL-C-83723 Series III design concepts, Pyle-National has also developed a series of High Temperature firewall connectors (featured on page 2), that are capable of operation at 260° C/500° F. A 100% scoop-proof version of the high temperature connector is also available under specification ESC 11/Pyle HTK Series. In addition, this connector series incorporates a unique sealing grommet that is capable of sealing on standard diameter wire as well as Kapton wire of reduced diameter.

This connector was developed for the higher operating temperatures inherent in today's newest high performance aircraft and aircraft engines. These connectors meet the performance requirements of the following specifications:

- Aerospatiale: ASN-EO44X Class KE/SE
- General Electric: M50TF3564
- European: AECMA EN2997
- Rolls Royce/SBAC:ESC 10/ESC 11

It is because of our history and proven design capability that we are able to offer connectors in environmental, firewall and hermetic classes that exceed even the most stringent specification requirements.

PERFORMANCE CHARACTERISTICS

Operating Temperature Data

Std: -85°F (-65°C) to 392°F (200°C).
Class K types meet fireproof test per MIL-C-83723 2000°F (1093°C).
High Temperature Series: Operates at 500°F (260°C).

Altitude

Sea Level to 110,000 feet.

Voltage Breakdown Rating

Service Rating I

Sea Level	1,500
50,000 feet	500
70,000 feet	375
110,000 feet	200

Current Rating

Size 20 contacts	7.5 amperes maximum
Size 16 contacts	13.0 amperes maximum
Size 12 contacts	23 amperes maximum

Contact Retention Strength

Exceeds MIL-C-83723 requirements.

Connector Durability

500 cycles per MIL-C-83723 for threaded coupling.
500 cycles per General Electric M50TF2321 for non-decoupling.

Humidity

To 98% relative humidity, including condensation.

Exposure

Freezing rain.

Non-Decoupling

Exceeds requirements of MIL-C-83723/95 and 96.
Non-decoupling feature tends to tighten connectors under vibration.

Vibration

Meets MIL-C-83723 of 41.7G's for 16 hours.
Boeing BACC63BR/BT for 36 hours.
General Electric vibration specifications.
M50TF2321 and M50TF2238 for 36 hours, which includes:

TEMPERATURE	G	TIME
EXTREMES	LEVEL	LENGTH
Room Temp.	60 G's	12 hours (4 hours each axis)
-65F ± 5°F	60 G's	12 hours (4 hours each axis)
350 ± 5°F	60 G's	12 hours (4 hours each axis)

ORDERING INFORMATION FOR THREADED/BAYONET SERIES

Military Designation

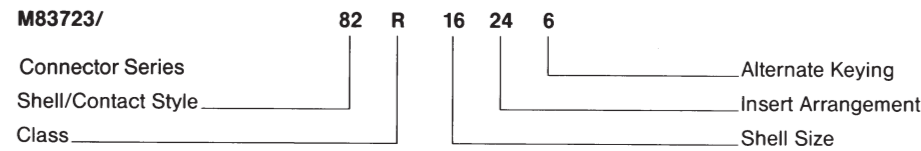

Shell/Contact Style

- 71—Bayonet, Square Flange Receptacle, Sockets
- 72—Bayonet, Square Flange Receptacle, Pins
- 73—Bayonet, Jam Nut Receptacle, Sockets
- 74—Bayonet, Jam Nut Receptacle, Pins
- 75—Bayonet, Plug, Sockets
- 76—Bayonet, Plug, Pins
- 82—Threaded, Square Flange Receptacle, Sockets
- 83—Threaded, Square Flange Receptacle, Pins
- 84—Threaded, Jam Nut Receptacle, Sockets
- 85—Threaded, Jam Nut Receptacle, Pins
- 86—Threaded, Straight Plug, Sockets
- 87—Threaded, Straight Plug, Pins
- 95—Threaded, Non-Decoupling Plug, Sockets
- 96—Threaded, Non-Decoupling Plug, Pins

Class

- A Aluminum, Black Anodized, Non-Conductive
- G Stainless Steel
- K Stainless Steel Firewall
- R Aluminum, Electroless Nickel Plated
- W Aluminum, Olive Drab Cadmium

Shell Size

8, 10, 12, 14, 16, 18, 20, 22, 24

Insert Arrangement

See Chart (page 9).

Alternate Keying

N=Normal, 6, 7, 8, 9 and Y* alternates.
 *Formerly 10 (see page 8).

Pyle Designation

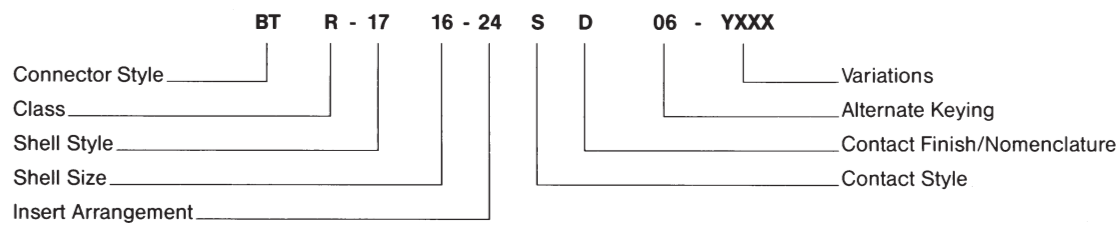

Connector Style

Standard Design

- BT—Threaded—'O' ring seal in receptacle
- BY—Bayonet—'O' ring seal in receptacle

Alternate Design

- BJ—Threaded, Stainless Steel—
 Static/Dynamic Seal in receptacle
- BN—Same as BJ except Electrodeposited
 Nickel Plate

Class

- A Aluminum, Black Anodized, Non-Conductive
- R Aluminum, Electroless Nickel Plated
- W Aluminum, Olive Drab Cadmium Over Nickel
- G Stainless Steel
- K Stainless Steel Firewall

Shell Style

- 10—Bayonet Plug
- 11—Threaded Straight Plug
- 12—Threaded Non-Decoupling Plug
- 17—Square Flange Receptacle
- 19—Jam Nut Receptacle

Shell Size

8, 10, 12, 14, 16 18, 20 22, 24, 28

Insert Arrangements

See Chart (page 9).

Contact Style (Crimp)

P = Pin S = Socket

Contact Finish/Nomenclature

D = gold per MIL-C-39029
 E = without contacts

Alternate Keying

(Omit for normal) 06, 07, 08, 09 and
 10 alternate (see page 8).

Variations

Consult factory for special variations.

CONTACT INFORMATION

Standard Contacts and Seal Plugs

CONTACT SIZE	SPEC NUMBER	SUPERSEDED NUMBER	PIN PART NUMBERS	
			PYLE NUMBER	
			HIGH PERFORMANCE*	STANDARD CONTACT
20	M39029/4-110	M83723-33B20	BA-4020-36LD	BA-4020-96LD
16	M39029/4-111	M83723-33B16	BA-4016-36LD	BA-4016-96LD
12	M39029/4-113	M83723-33B12	BA-4012-36LD	BA-4012-96LD

*Recommended for high vibration areas.

CONTACT SIZE	PIN COLOR BANDS		
	1st BAND	2nd BAND	3rd BAND
20	Brown	Brown	Black
16	Brown	Brown	Brown
12	Brown	Brown	Orange

COLOR BANDS

Pin

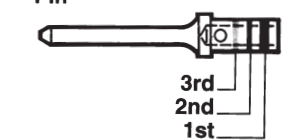

CONTACT SIZE	SPEC NUMBER	SUPERSEDED NUMBER	SOCKETS PART NUMBERS	
			PYLE NUMBER	
			HIGH PERFORMANCE*	STANDARD CONTACT
20	M39029/5-115	M83723-34B20	BA-4120-36LD	BA-4120-96LD
16	M39029/5-116	M83723-34B16	BA-4116-36LD	BA-4116-96LD
12	M39029/5-118	M83723-34B12	BA-4112-36LD	BA-4112-96LD

*Recommended for high vibration areas. Sockets feature 4 tine construction with supporting spring bands.

CONTACT SIZE	SOCKET COLOR BANDS		
	1st BAND	2nd BAND	3rd BAND
20	Brown	Brown	Green
16	Brown	Brown	Blue
12	Brown	Brown	Gray

COLOR BANDS

Socket

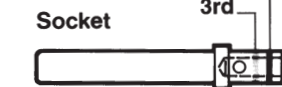

Seal Plugs

CONTACT SIZE	MS NUMBER	PYLE NUMBER
20	MS27488-20	BA-4020-59P
16	MS27488-16	BA-4016-59P
12	MS27488-12	BA-4012-59P

Standard Contact Rating

CRIMP CONTACT SIZE	Test Current Standard	CRIMP WELL DATA	
		Well Diameter	Min. Well Depth
20	7.5	.049	.157
16	13.0	0.067	.250
12	23.0	.100	.250

HERMETIC CONNECTORS SPECIFICATIONS

HERMETIC D-HOLE MOUNT RECEPTACLE MIL-C-83723/89 THREADED TYPE

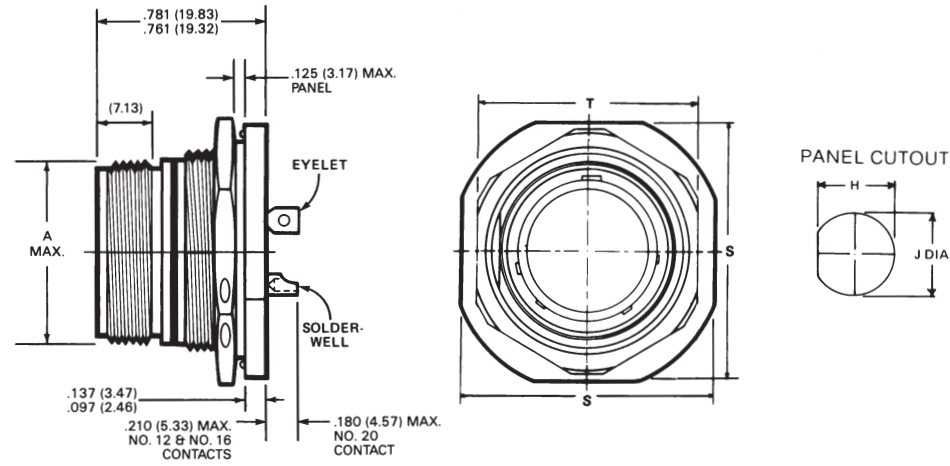

Shell Size	INCHES					MILLIMETERS				
	A Dia. (Max.)	H Flats ±.005	J Dia. ±.005	S Flats (Max.)	T Hex (Max.)	A Dia. (Max.)	H Flats ±.13	J Dia. ±.13	S Flats (Max.)	T Hex (Max.)
08	.562	.605	.635	.980	.828	14.27	15.37	16.13	24.89	21.03
10	.696	.730	.760	1.104	.953	17.68	18.54	19.30	28.04	24.21
12	.875	.917	.947	1.291	1.140	22.23	23.29	24.05	32.79	28.96
14	.936	.980	1.010	1.391	1.205	23.77	24.89	25.65	35.33	30.61
16	1.062	1.105	1.135	1.516	1.329	26.97	28.07	28.83	38.51	33.76
18	1.187	1.225	1.260	1.641	1.455	30.15	31.12	32.00	41.68	36.96
22	1.437	1.475	1.510	1.954	1.705	36.47	37.47	38.35	49.63	43.31

TOOLS

CONTACT SIZE	Crimp Tool	Adjustable Turret	Checking Gauge For M22520/1-01 Crimping Tool	Insertion/Removal Tools
20	M22520/1-01 Pyle-National TP-201354	M22520/1-02 Pyle-National TP-201355	M22520/3 Pyle-National TP-201356	M81969/14-11 Pyle-National TP-201343-20-BA
16	M22520/1-01 Pyle-National TP-201354	M22520/1-02 Pyle-National TP-201355	M22520/3 Pyle-National TP-201356	M81969/14-03 Pyle-National TP-201343-16-BA
12	M22520/1-01 Pyle-National TP-201354	M22520/1-02 Pyle-National TP-201355	M22520/3 Pyle-National TP-201356	M81969/14-04 Pyle-National TP-201343-12-BA
8 Twinax*	-	-	-	TP-201391-08

* See Bulletin MS-103 for details.

ORDERING INFORMATION FOR BOEING COMPANY

Boeing Designation (BACC63BR/BT Firewall)

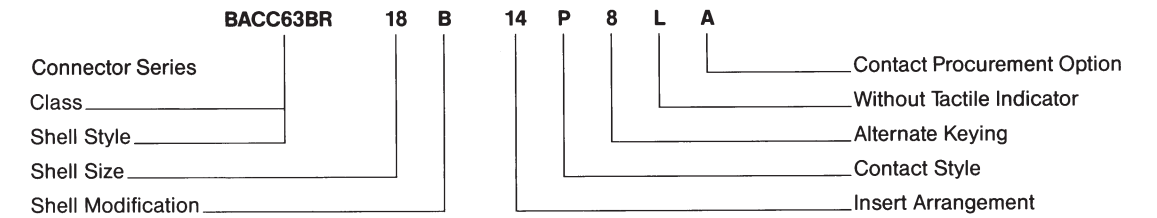

Shell Style
 BR—Non-Decoupling Plug, Firewall
 BT—Square Flange Receptacle, Firewall

Boeing Specification Qualified Shell Sizes
 12, 14, 16, 18, 20, 22, 24, 28

Boeing Specification Qualified Insert Arrangements
 12-03, 14-04, 14-07, 16-10, 18-14, 20-16, 22-19, 24-30, 28-42

Shell Modifications
 B = 360° Accessory Teeth per MS3155
 D = 360° Accessory Teeth per MS3155 with Grounding Spring on plug
 -- = Accessory Teeth per MIL-C-83723 III

Contact Style
 P = Pin S = Socket
 (Gold Plate per MIL-C-39029)

Alternate Keying
 N = Normal, 6, 7, 8, 9 and 10 (see page 8).

Contact Procurement Option
 A = Without Contacts and Seal Plugs (Letter 'A' to be used on Purchase Orders only and will not appear on Connector as part of Connector Part Number)

Pyle Designation

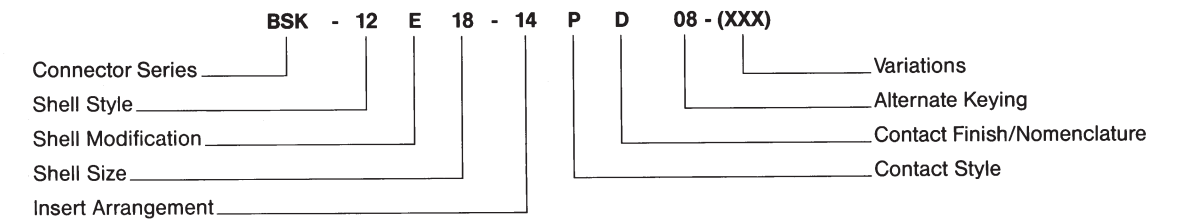

Connector Series
 BSK—Threaded, Stainless Steel Firewall Qualified to Boeing Co. BACC63BR/BT Specifications ("O" Ring Designation)

Shell Style
 12—Threaded Non-Decoupling Plug
 17—Square Flange Receptacle

Shell Modification
 E = 360° Accessory Teeth per MS3155 plug & receptacle
 F = 360° Accessory Teeth per MS3155 with Grounding Spring on plug only
 (Blank) = Accessory Teeth per MIL-C-83723 III

Shell Size
 12, 14, 16, 18, 20, 22, 24, 28

Insert Arrangements
 See Chart (page 9).

Contact Style
 P = Pin S = Socket

Contact Finish/Nomenclature
 D = Gold per MIL-C-39029
 E = Without Contacts

Alternate Keying
 (Omit for Normal) 06, 07, 08, 09 and 10 (see page 8).

Variations
 Y126—Contact Marking per MIL-C-83723/33 & 34 (Required with BACC63BR/BT Series)

Service Class - Military and Pyle

A Non-Corrosive Anodized Aluminum **K** Corrosion Resistant Stainless Steel, Firewall Capability
G Corrosion Resistant Stainless Steel **R** Conductive Finish Electroless Nickel Plated Aluminum
W Olive Drab, Cadmium over Nickel Plated Aluminum

ORDERING INFORMATION—EUROPEAN STANDARDS

Pyle Designation

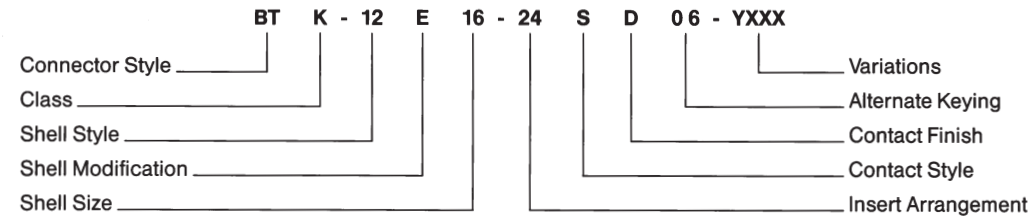

Style

- BT Threaded, 'O' Ring Seal (Std)
- BJ Threaded, Static/Dynamic Seal (Optional)

Class

- G Stainless Steel
- K Stainless Steel Firewall
- R Aluminum, Electroless Nickel Plated
- W Aluminum, Olive Drab Cadmium over Nickel

Shell Style

- 12 Non-Decoupling Plug
- 17 Square Flange Receptacle
- 19 Jam Nut Receptacle

Shell Modification

- E = 360° Accessory Teeth per MS3155
- F = 360° Accessory Teeth per MS3155 with Grounding Spring on plug

Shell Size

- 8, 10, 12, 14, 16, 18, 20, 22, 24, 28

Insert Arrangement

See Chart (page 9)

Contact Style

- P = Standard pin
- K = #20 pin with #18 crimpwell
- S = Standard socket
- L = #20 socket with #18 crimpwell

Contact Finish

- D = Gold per MIL-C-39029 (Special High Temperature Contact—See Chart page 19)
- E = Without Contacts per ESC 10

Alternate Keying

(Omit for Normal) 06, 07, 08, 09 and 10 alternates

Variations

- Y144 260°C Capability (Euro Market)
- Y163 200°C Capability (Euro Market)
- Y175 Superseded by Y144
- Y176 260°C per G.E. M50TF3564, Class B, No Accessory Teeth
- Y185 Superseded by Y163
- Y186 260°C Capability per G.E. M50TF3564 Class B
- Y188 200°C Capability per G.E. M50TF3564 Class A

Pyle Designation—ESC 11 Series

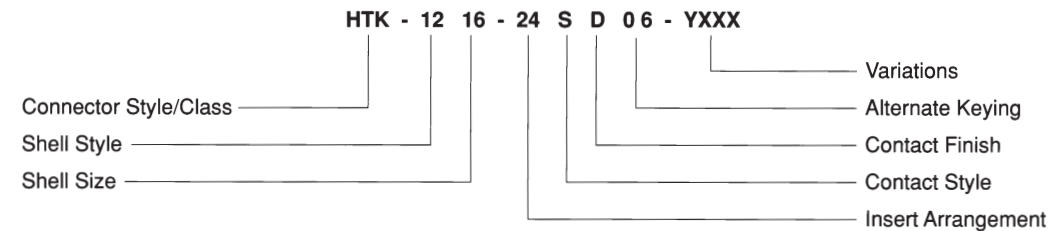

Style/Class

- HTK Standard ESC 11, Class K
- HNK Nickel Finish, Class K, Static/Dynamic Seal

Shell Style

- 12 Non-Decoupling Plug
- 17 Square Flange Receptacle

Shell Size

- 12, 14, 16, 18, 20, 22, 24

Insert Arrangement

See Chart (page 9)

Contact Style

- P = Pin
- S = Socket

Contact Finish

- D = Gold per MIL-C-39029 (optional) (Special High Temperature Contacts—See page 19)
- E = Without Contacts per ESC 11

Alternate Keying

(Omit for Normal) 06, 07, 08 and 09 Alternates—Not intermateable with ESC 10 (See page 8)

Variations

- Y144 260°C
- Y163 200°C
- Y186 260°C per GE M50TF3564, Class B
- Y188 200°C per GE M50TF3564, Class A

HERMETIC CONNECTORS SPECIFICATIONS

HERMETIC SOLDER MOUNT RECEPTACLE MIL-C-83723/90 THREADED TYPE

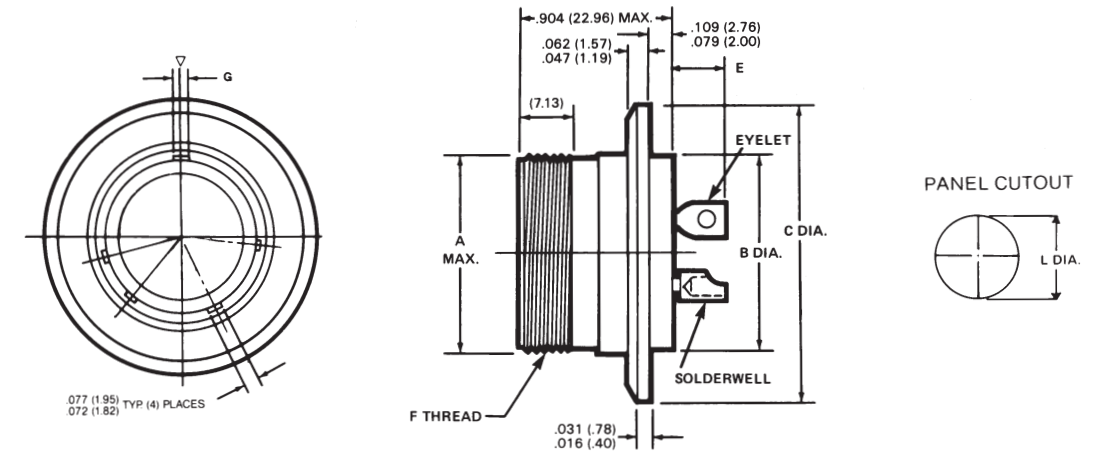

INCHES

Shell Size	A Dia. (Max.)	B Dia. (Max.)	C Dia. ±.010	E		F Coupling Thread UNEF-2A	G Dim. ±.003	L Dia. ±.005
				#20 Contacts	#12 & #16 Contacts			
08	.562	.500	.713	.194/.134	.224/.164	.562-24	.094	.510
10	.696	.562	.840	.194/.134	.224/.164	.688-24	.094	.572
12	.875	.750	1.045	.194/.134	.224/.164	.875-20	.094	.760
14	.936	.812	1.090	.194/.134	.224/.164	.938-20	.094	.822
16	1.062	.937	1.210	.194/.134	.224/.164	1.062-18	.125	.947
18	1.187	1.062	1.340	.194/.134	.224/.164	1.188-18	.125	1.072
22	1.437	1.312	1.562	.194/.134	.224/.164	1.438-18	.125	1.322

MILLIMETERS

Shell Size	A Dia. (Max.)	B Dia. (Max.)	C Dim. ±.25	E		G Dim. ±.08	L Dia. ±.13
				#20 Contacts	#12 & #16 Contacts		
08	14.27	12.70	18.11	4.93/3.40	5.69/4.17	2.39	12.95
10	17.68	14.27	21.34	4.93/3.40	5.69/4.17	2.39	14.53
12	22.23	19.05	26.54	4.93/3.40	5.69/4.17	2.39	19.30
14	23.77	20.62	27.69	4.93/3.40	5.69/4.17	2.39	20.88
16	26.97	23.80	30.73	4.93/3.40	5.69/4.17	3.18	24.05
18	30.15	26.97	34.04	4.93/3.40	5.69/4.17	3.18	27.23
22	36.50	33.32	39.67	4.93/3.40	5.69/4.17	3.18	33.58

HERMETIC CONNECTORS SPECIFICATIONS

HERMETIC FLANGE MOUNT RECEPTACLE MIL-C-83723/88 THREADED TYPE

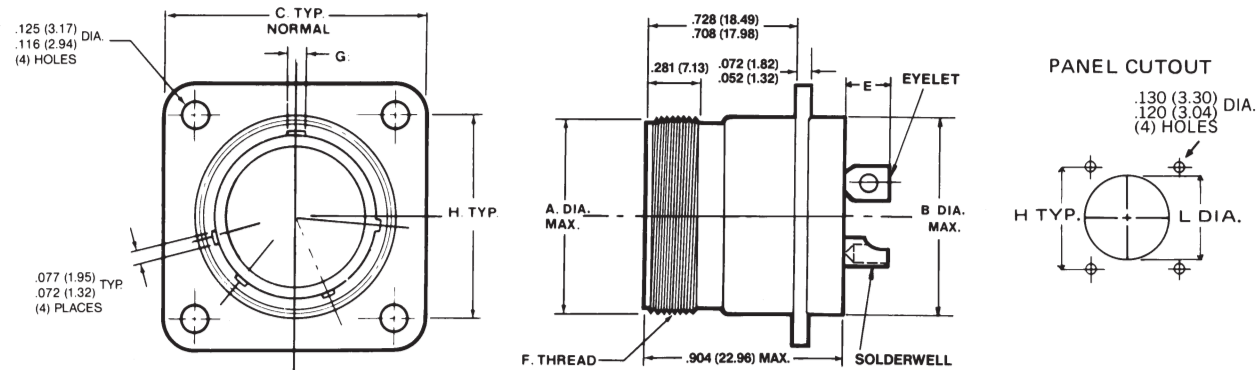

Shell Size	INCHES								
	A Dia. (Max.)	B Dia. (Max.)	C Dim. ±.010	E		F Coupling Thread UNEF-2A	G Dim. ±.003	H ±.005	L Dia. ±.005
				#20 Contacts	#12 & #16 Contacts				
08	.562	.500	.812	.194/.134	.224/.164	.562-24	.094	.594	.572
10	.696	.562	.937	.194/.134	.224/.164	.688-24	.094	.719	.706
12	.875	.750	1.031	.194/.134	.224/.164	.875-20	.094	.812	.885
14	.936	.812	1.125	.194/.134	.224/.164	.938-20	.094	.906	.946
16	1.062	.937	1.250	.194/.134	.224/.164	1.062-18	.125	.969	1.072
18	1.187	1.062	1.343	.194/.134	.224/.164	1.188-18	.125	1.062	1.197
22	1.437	1.312	1.562	.194/.134	.224/.164	1.438-18	.125	1.250	1.447

Shell Size	MILLIMETERS								
	A Dia. (Max.)	B Dia. (Max.)	C Dim. ±.25	E		G Dim. ±.08	H ±.13	L Dia. ±.13	
				#20 Contacts	#12 & #16 Contacts				
08	14.27	12.70	20.62	4.93/3.40	5.69/4.17	2.39	15.09	14.53	
10	17.68	14.27	23.80	4.93/3.40	5.69/4.17	2.39	18.26	17.93	
12	22.23	19.05	26.19	4.93/3.40	5.69/4.17	2.39	20.62	22.48	
14	23.77	20.62	28.58	4.93/3.40	5.69/4.17	2.39	23.01	24.03	
16	26.97	23.80	31.75	4.93/3.40	5.69/4.17	3.18	24.61	27.23	
18	30.15	26.97	34.11	4.93/3.40	5.69/4.17	3.18	26.91	30.40	
22	36.50	33.32	36.50	4.93/3.40	5.69/4.17	3.18	31.75	36.75	

ORDERING INFORMATION—EUROPEAN STANDARDS

AECMA Designation

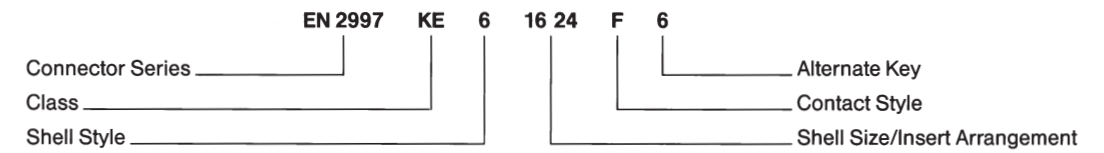

Connector Series

EN 2997 AECMA designation
NFL 54143 European designation

Class

STANDARD TEMPERATURE

R Aluminum, Electroless Nickel Plated (200°C)
RS Same as R with Grounding Spring on plug
W Aluminum, Olive Drab Cadmium Over Nickel (175°C)
WS Same as W with Grounding Spring on plug
K Stainless Steel Firewall (200°C)
S Same as K with Grounding Spring on plug
Y Stainless Steel Hermetic with Solderwell Contact (200°C)

HIGH TEMPERATURE (260°C)

KE Stainless Steel Firewall
SE Same as KE with Grounding Spring
YE Stainless Steel Hermetic with Solderwell Contact

Shell Style

0 Square Flange Receptacle
1 Solder Mount Receptacle (Hermetic Only)
6 Plug, Non-Decoupling
7 Jam Nut Receptacle

Shell Size

8, 10, 12, 14, 16, 18, 20, 24, 28

Insert Arrangement

See Chart (Page 9)

Contact Style

M = Standard pin, C=#20 pin with #18 crimpwell
A = Pin insert less contacts
F = Standard socket
D = #20 socket with #18 crimpwell
B = Socket insert less contacts

Alternate Keying

N=Normal, 6, 7, 8, 9 and Y

Society of British Aerospace Companies/Rolls Royce Standards

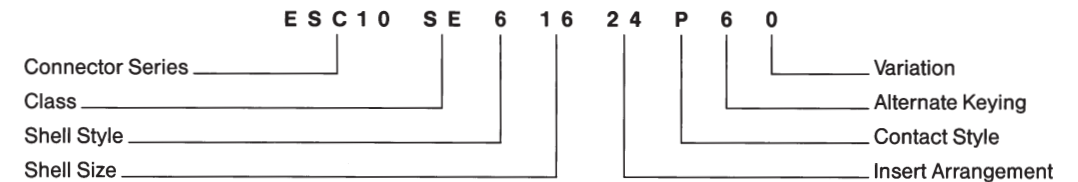

Connector Series

ESC 10 Basic High Temperature Connector
ESC 11 100% Scoop Proof-High Temperature Connector

Class

KE: Stainless Steel, Firewall (260°C)
SE: Stainless Steel, Firewall (260°C) with Grounding Spring
YE: Stainless Steel Hermetic (260°C)

Shell Style

0 Square Flange Receptacle with 360° accessory teeth per MS3155
1 Hermetic, Solder Mount
2 Hermetic, Square Flange
3 Hermetic, Jam Nut
6 Plug, Non-decoupling with 360° accessory teeth per MS3155

Shell Size

8, 10, 12, 14, 16, 18, 20, 22, 24, 28

Insert Arrangement

See Chart (page 9)

Contact Style

P = Pin S = Socket
(All connectors supplied w/o contacts except Shell Styles 1, 2, and 3)

Alternate Keying

N = Normal, 6, 7, 8, and 9 alternates

Variations

O = Basic Connector
Alphabetic identifiers as assigned
A = Lockwires holes on plug

ORDERING INFORMATION—EUROPEAN STANDARDS

Aerospatiale Designation

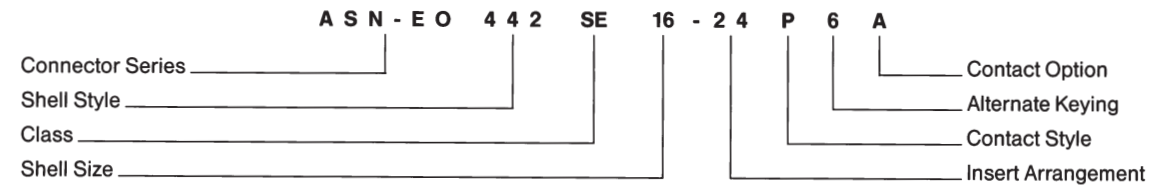

Shell Style

- 195*: Plug, Non-decoupling, accessory teeth per MIL-C-83723 III, Stainless steel
- 197*: Square Flange Receptacle, accessory teeth per MIL-C-83723 III, Stainless steel
- 320*: Plug, Non-decoupling, accessory teeth per MIL-C-83723 III, Aluminum
- 321*: Jam Nut Rec., accessory teeth per MIL-C83723 III, Aluminum
- 322*: Square Flange Rec., accessory teeth per MIL-C-83723 III, Aluminum
- 441: Plug, Non-decoupling, 360° accessory teeth per MS3155, Stainless steel
- 442: Plug, Non-decoupling, 360° accessory teeth per MS3155, with grounding spring, Stainless steel
- 443*: Square flange Receptacle, accessory teeth per MIL-C-83723 III, Stainless steel
- 444: Same as 443 with 360° accessory teeth per MS3155
- 451: Plug, Non-decoupling, 360° accessory teeth per MS3155
- 452: Plug, Non-decoupling, 360° accessory teeth per MS3155, with grounding spring, aluminum
- 453*: Square Flange Rec., 360° accessory teeth per MS3155, Aluminum
- 454: Same as 453 with 360° accessory teeth per MS3155

*Not active for new design

Class

- K: Stainless Steel, Firewall, 200°C
- KE: Stainless Steel, Firewall, 260°C
- R: Aluminum, Electroless Nickel Finish, 200°C
- RS: Aluminum Electroless Nickel Finish, 200°C, with grounding spring on plug
- S: Stainless Steel, Firewall, 200°C, with grounding spring on plug
- SE: Stainless Steel, Firewall, 260°C, with grounding spring on plug

Shell Size

8, 10, 12, 14, 16, 18, 20, 22, 24, 28

Insert Arrangement

See Chart (page 9)

Contact Style

P = Pin S = Socket

Alternate Keying

N = Normal, 6, 7, 8, 9 and Y

Contact Option

Omit = with Contacts

A = without Contacts

Note: Per ASN-E, #20 contacts with #18 crimpwell supplied standard when ordered with connectors.

ALTERNATE KEYING

ALTERNATE POLARITY
 KEYWAY ARRANGEMENTS
 View of front face of receptacle shell.
 Angles are counter clockwise from "N" keyway. For plug shell, the key locations are clockwise when viewed from front of plug.

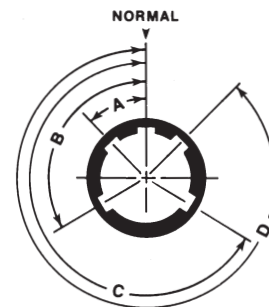

ESC 11 (ONLY)

Position	For Connectors Size 8 and 10				For Connectors Size 12, 14, 16, 18, 20, 22, 24, and 28			
	A	B	C	D	A	B	C	D
Normal	105°	140°	215°	265°	105°	140°	215°	265°
6	102°	132°	248°	320°	18°	149°	192°	259°
7	80°	118°	230°	312°	92°	152°	222°	342°
8	35°	140°	205°	275°	84°	152°	204°	334°
9	64°	155°	234°	304°	24°	135°	199°	240°
Y(10°)	25°	115°	220°	270°	98°	152°	268°	338°

*Not Available in Size 8 Connector

Position	For Connectors Size 14 thru 24			
	A	B	C	D
Normal	95	145	220	255
6	101	168	211	342
7	18	138	208	268
8	26	156	208	276
9	120	161	225	336

MIL-C-83723 HERMETIC CONNECTORS

PERFORMANCE CHARACTERISTICS

Thermal Shock (Unmated)	No damage detrimental to the operation of the connector occurs when subjected to 10 cycles of thermal shock from 0°C to 90°C and back to 0°C.	Air Leakage (Unmated)	Less than .01 micron per cubic feet per hour on application of 15 PSI pressure differential across the connector.
Physical Shock (Mated)	300 g's	Altitude Immersion (Mated)	After 3 cycles immersed in salt water with pressure reduced to 1 in. Hg. (75,000 ft. altitude) for 30 minutes and returned to atmospheric pressure. While connectors submerged insulation resistance should remain 1000 megohms minimum and support 1500 volts RMS applied without flashover or breakdown.
Moisture Resistance (Mated)	500 Megohms	High Potential Voltage Altitude (Unmated)	When tested in accordance with MIL-STD-202, Method 301, no flash-over or breakdown under simulated altitude conditions as shown:
Insulation Resistance High Temperature (Mated)	500 Megohms	Altitude	50,000/Service Rating I 500 AC-RMS 70,000 375 AC-RMS 110,000 200 AC-RMS
Corrosion (Unmated)	Comply with MIL-C-83723 Req.		
Temperature Life	Fully functional for 1000 hours at 200°C (392°F) ambient. Internal temperature 238°C (460°F)		

HERMETIC ORDERING INFORMATION

Military Designation

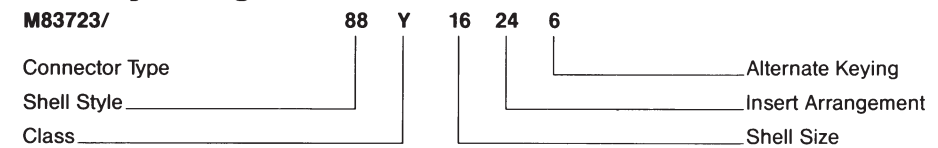

Shell Style

- 88—Square Flange Receptacle
- 89—D-Hole Mounted Receptacle
- 90—Solder Mounted Receptacle

Class

Y Stainless Steel

Shell Size

8, 10, 12, 14, 16, 18, 22

Insert Arrangements

See Chart (page 9).

Alternate Keying

N = Normal 6, 7, 8, 9 and Y* alternates

*Formerly 10 (see page 8).

Pyle Designation

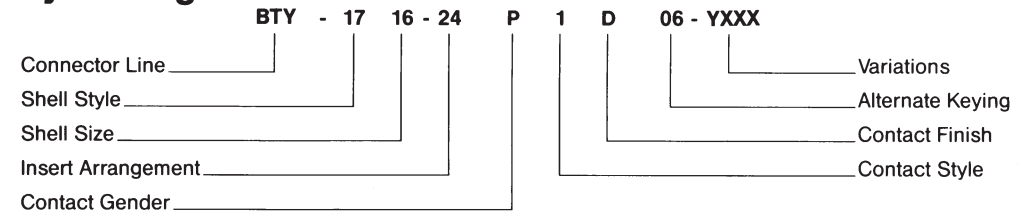

Connector Line

- BTY—Threaded Hermetic—'O' Ring Seal—Stainless Steel Shell
- BFY—Threaded Hermetic—Static/Dynamic Seal—Stainless Steel Shell
- BNY—Threaded Hermetic—Static/Dynamic Seal, Stainless Steel, Electrodeposited Nickel

Shell Style

- 17—Square Flange Receptacle
- 19—D-Hole Mounted Receptacle
- 14—Solder Mounted Receptacle

Shell Size

08, 10, 12, 14, 16, 18, 22

Insert Arrangements

See Chart (page 9).

Contact Gender

P = Pin

Contact Style

1 = Solderwell (Mil Spec. Type) 4 = Eyelet

Contact Finish

D = .000050 (per MIL-C-83723 III) gold

V = .000100 gold

Alternate Keying

(Omit for Normal) 06, 07, 08, 09 and 10 (see page 8).

Variations

Y144 260°C Capability (Euro Market)

Y163 200°C Capability (Euro Market)

Y186 260°C Capability per G.E. M50TF3564, Class B

Y188 200°C Capability per G.E. M50TF3564, Class A

Consult factory for other special variations.

SPECIFICATIONS

PLUGS

Standard Plug MIL-C-83723/ 86 & 87 Type

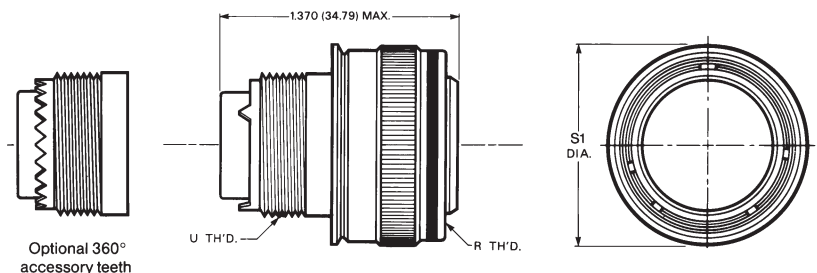

Optional 360° accessory teeth

Non-Decoupling Plug MIL-C-83723/ 95 & 96 Type

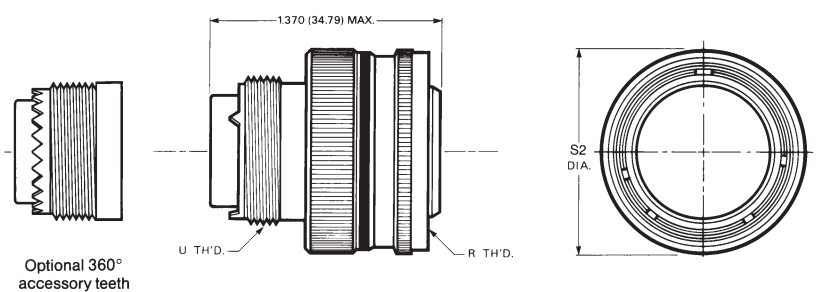

Optional 360° accessory teeth

Bayonet Plug MIL-C-83723/ 75 & 76 Type

SHELL SIZE 28 NOT AVAILABLE.

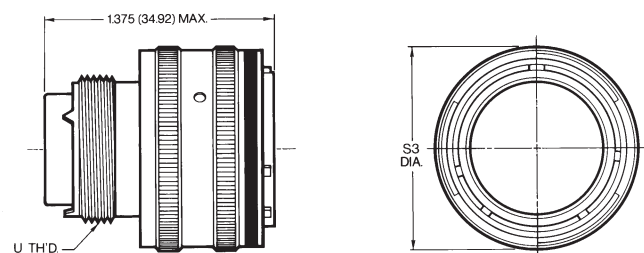

Shell Size	INCHES			MILLIMETERS				
	U Th'd. Access End	R Th'd. Mating End	S1 Dia. (Max.)	S2 Dia. (Max.)	S3 Dia. (Max.)	S1 Dia. (Max.)	S2 Dia. (Max.)	S3 Dia. (Max.)
08	.500-20	.562-24	.776	.832	.765	19.71	21.13	19.43
10	.625-24	.688-24	.906	.958	.906	23.01	24.33	23.01
12	.750-20	.875-20	1.078	1.090	1.078	27.38	27.68	27.38
14	.875-20	.938-20	1.141	1.203	1.125	28.98	30.55	28.57
16	1.000-20	1.062-18	1.266	1.326	1.266	32.15	33.68	32.15
18	1.062-18	1.188-18	1.375	1.432	1.375	34.92	36.37	34.92
20	1.188-18	1.312-18	1.500	1.557	1.505	38.1	39.54	38.22
22	1.312-18	1.438-18	1.625	1.682	1.625	41.27	42.72	41.27
24	1.438-18	1.562-18	1.750	1.817	1.755	44.45	46.15	44.57
28	1.750-18	1.812-16	2.000	2.122	—	50.8	53.89	—

SPECIFICATIONS

FLANGE MOUNT RECEPTACLES

MIL-C-83723/ 82 & 83 Threaded Type

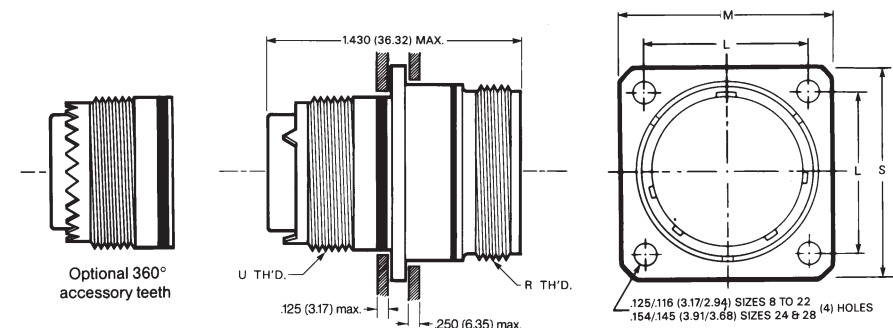

Optional 360° accessory teeth

MIL-C-83723/ 71 & 72 Bayonet Type

SHELL SIZE 28 NOT AVAILABLE.

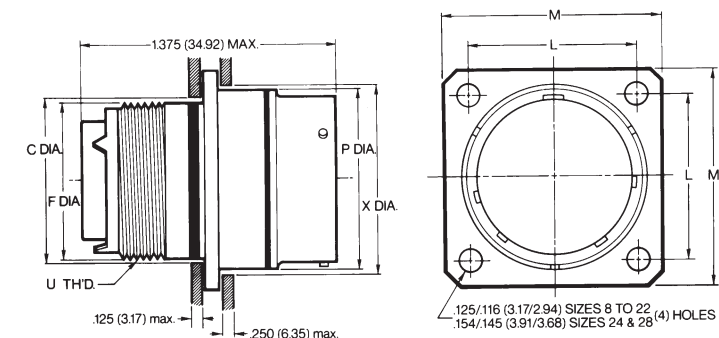

INCHES

Shell Size	U Th'd. Access End	R Th'd. Mating End	C Dia. Panel (Min.)	F Dia. Rear (Max.)	P Dia. Front (Max.)	X Dia. Panel (Min.)	L	M
08	.500-20	.562-24	.510	.500	.562	.620	.594	.812
10	.625-24	.688-24	.635	.625	.696	.748	.719	.937
12	.750-20	.875-20	.760	.750	.875	.913	.812	1.031
14	.875-20	.938-20	.885	.875	.936	.980	.906	1.125
16	1.000-20	1.062-18	1.010	1.000	1.062	1.107	.969	1.250
18	1.062-18	1.188-18	1.072	1.062	1.187	1.209	1.062	1.343
20	1.188-18	1.312-18	1.192	1.187	1.312	1.337	1.156	1.437
22	1.312-18	1.438-18	1.322	1.312	1.437	1.452	1.250	1.562
24	1.438-18	1.562-18	1.447	1.437	1.562	1.577	1.375	1.703
28	1.750-18	1.812-16	1.760	1.750	1.812	1.827	1.562	1.953

MILLIMETERS

Shell Size	C Dia. Panel (Min.)	F Dia. Rear (Max.)	P Dia. Front (Max.)	X Dia. Panel (Min.)	L	M
08	12.95	12.70	14.27	15.75	15.04	20.62
10	16.13	15.88	17.68	18.99	18.26	23.80
12	19.30	19.05	22.23	23.19	20.62	26.19
14	22.48	22.23	23.77	24.89	23.01	28.58
16	25.65	25.40	26.97	28.12	24.61	31.75
18	27.23	26.97	30.15	30.71	26.97	34.11
20	30.28	30.15	33.32	33.96	29.36	36.50
22	33.58	33.32	36.50	36.88	31.75	39.67
24	36.75	36.50	39.67	40.06	34.93	43.26
28	44.70	44.45	46.02	46.41	39.67	49.61

SPECIFICATIONS

PLUGS

Standard Plug MIL-C-83723/ 86 & 87 Type

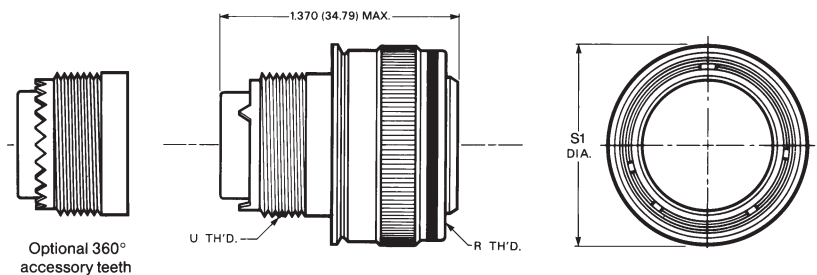

Non-Decoupling Plug MIL-C-83723/ 95 & 96 Type

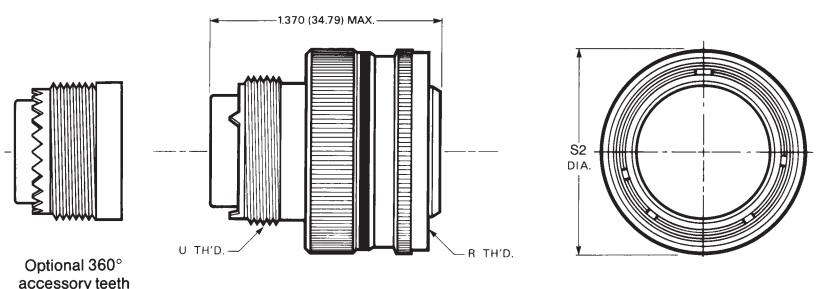

Bayonet Plug MIL-C-83723/ 75 & 76 Type

SHELL SIZE 28 NOT AVAILABLE.

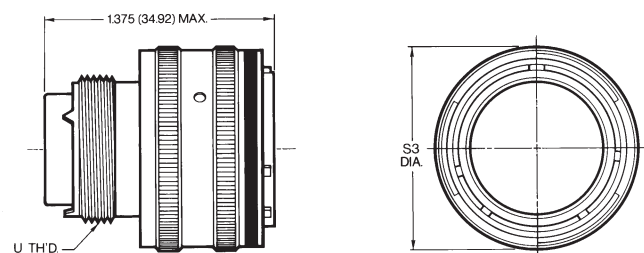

Shell Size	INCHES			MILLIMETERS				
	U Th'd. Access End	R Th'd. Mating End	S1 Dia. (Max.)	S2 Dia. (Max.)	S3 Dia. (Max.)	S1 Dia. (Max.)	S2 Dia. (Max.)	S3 Dia. (Max.)
08	.500-20	.562-24	.776	.832	.765	19.71	21.13	19.43
10	.625-24	.688-24	.906	.958	.906	23.01	24.33	23.01
12	.750-20	.875-20	1.078	1.090	1.078	27.38	27.68	27.38
14	.875-20	.938-20	1.141	1.203	1.125	28.98	30.55	28.57
16	1.000-20	1.062-18	1.266	1.326	1.266	32.15	33.68	32.15
18	1.062-18	1.188-18	1.375	1.432	1.375	34.92	36.37	34.92
20	1.188-18	1.312-18	1.500	1.557	1.505	38.1	39.54	38.22
22	1.312-18	1.438-18	1.625	1.682	1.625	41.27	42.72	41.27
24	1.438-18	1.562-18	1.750	1.817	1.755	44.45	46.15	44.57
28	1.750-18	1.812-16	2.000	2.122	—	50.8	53.89	—

SPECIFICATIONS

FLANGE MOUNT RECEPTACLES

MIL-C-83723/ 82 & 83 Threaded Type

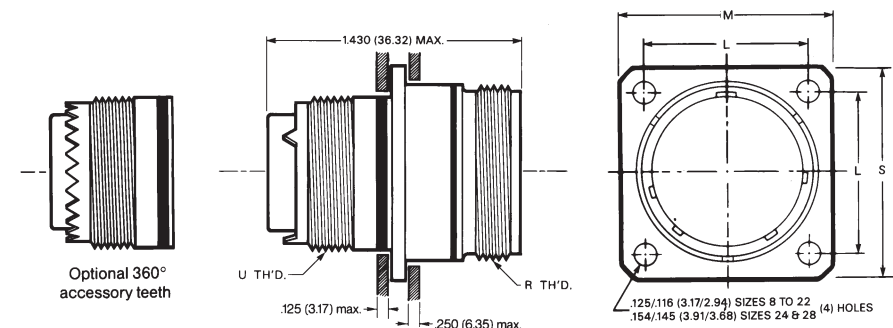

MIL-C-83723/ 71 & 72 Bayonet Type

SHELL SIZE 28 NOT AVAILABLE.

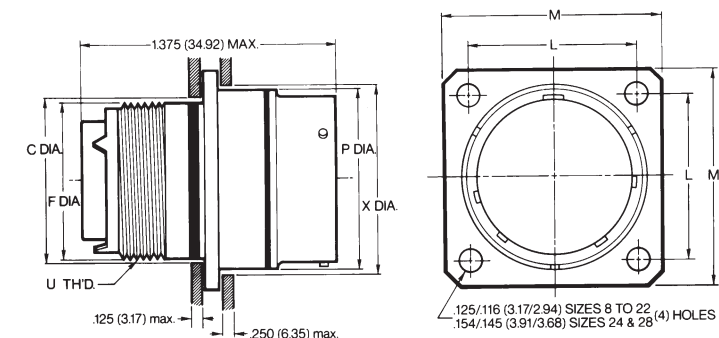

INCHES

Shell Size	U Th'd. Access End	R Th'd. Mating End	C Dia. Panel (Min.)	F Dia. Rear (Max.)	P Dia. Front (Max.)	X Dia. Panel (Min.)	L	M
08	.500-20	.562-24	.510	.500	.562	.620	.594	.812
10	.625-24	.688-24	.635	.625	.696	.748	.719	.937
12	.750-20	.875-20	.760	.750	.875	.913	.812	1.031
14	.875-20	.938-20	.885	.875	.936	.980	.906	1.125
16	1.000-20	1.062-18	1.010	1.000	1.062	1.107	.969	1.250
18	1.062-18	1.188-18	1.072	1.062	1.187	1.209	1.062	1.343
20	1.188-18	1.312-18	1.192	1.187	1.312	1.337	1.156	1.437
22	1.312-18	1.438-18	1.322	1.312	1.437	1.452	1.250	1.562
24	1.438-18	1.562-18	1.447	1.437	1.562	1.577	1.375	1.703
28	1.750-18	1.812-16	1.760	1.750	1.812	1.827	1.562	1.953

MILLIMETERS

Shell Size	C Dia. Panel (Min.)	F Dia. Rear (Max.)	P Dia. Front (Max.)	X Dia. Panel (Min.)	L	M
08	12.95	12.70	14.27	15.75	15.04	20.62
10	16.13	15.88	17.68	18.99	18.26	23.80
12	19.30	19.05	22.23	23.19	20.62	26.19
14	22.48	22.23	23.77	24.89	23.01	28.58
16	25.65	25.40	26.97	28.12	24.61	31.75
18	27.23	26.97	30.15	30.71	26.97	34.11
20	30.28	30.15	33.32	33.96	29.36	36.50
22	33.58	33.32	36.50	36.88	31.75	39.67
24	36.75	36.50	39.67	40.06	34.93	43.26
28	44.70	44.45	46.02	46.41	39.67	49.61

SPECIFICATIONS

D-HOLE MOUNTED RECEPTACLES

MIL-C-83723/ 84 & 85 Threaded Type

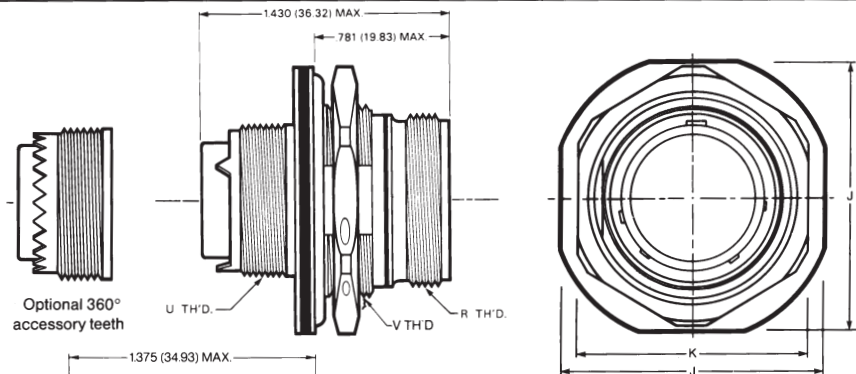

MIL-C-83723/ 73 & 74 Bayonet Type

SHELL SIZE 28 NOT AVAILABLE.

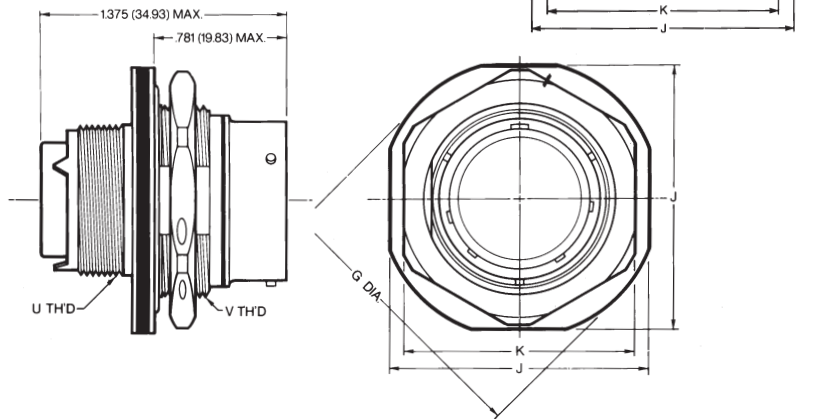

INCHES								
Shell Size	U Th'd. Access End	V Th'd.	R Th'd. Mating End	G Dia. (Max.)	J (Max.)	K (Hex)	Y Dia.	Z
08	.500-20	.625-20	.562-24	1.068	.979	.828	.635	.605
10	.625-24	.750-20	.688-24	1.192	1.104	.953	.760	.730
12	.750-20	.938-20	.875-20	1.380	1.291	1.140	.947	.917
14	.875-20	1.000-20	.938-20	1.505	1.391	1.205	1.010	.980
16	1.000-20	1.125-18**	1.062-18	1.630	1.516	1.329	1.135	1.105
18	1.062-18	1.250-18	1.188-18	1.756	1.641	1.455	1.260	1.225
20	1.188-18	1.375-18	1.312-18	1.860	1.766	1.574	1.385	1.350
22	1.312-18	1.500-18	1.438-18	2.068	1.954	1.705	1.510	1.475
24	1.438-18	1.625-18	1.562-18	2.160	2.074	1.830	1.635	1.600
28	1.750-18	1.875-20	1.812-16	—	2.329	2.080	1.885	1.850

**V Th'd. = 1.125-20 For Bayonet Style

MILLIMETERS					
Shell Size	G Dia. (Max.)	J (Max.)	K (Hex)	Y Dia.	Z
08	27.13	24.87	21.03	16.13	15.37
10	30.28	28.04	24.21	19.30	18.54
12	35.05	32.79	28.96	24.05	23.29
14	38.23	35.33	30.61	25.65	24.89
16	41.40	38.51	33.76	28.83	28.07
18	44.60	41.68	36.96	32.00	31.12
20	47.24	44.86	39.98	35.18	34.29
22	52.53	49.63	43.31	38.35	37.47
24	80.26	52.68	46.48	41.53	40.64
28	—	59.16	52.83	47.88	46.99

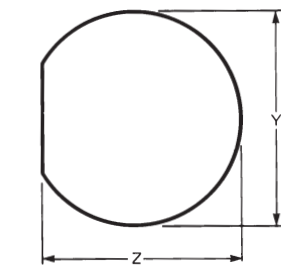

Panel Cutout Hole
(Panel Thickness .125/.062)

INSERT ARRANGEMENTS

Front Face of Pin Inserts Illustrated

*Non-Military Arrangement.

Insert arrangement size of contacts service rating

08-98 3 #20	08-03 3 #20	10-05 5 #20	10-06 6 #20	10-20 2 #16	12-03 3 #16	12-12 12 #20	14-04 4 #12	14-07 7 #16
14-12 9 #20, 3 #16	14-15 15 #20	16-10 10 #16	16-24 24 #20	18-08 8 #12	18-14 14 #16	18-31 31 #20	20-16 16 #16	20-25 19 #20, & 6 #12
20-39 37 #20, & 2 #16	20-41 41 #20	22-19 19 #16	22-55 55 #20	24-19 19 #12	24-30* 30 #16	24-46* 40 #20, 4 #16, 2 #8 Twinax Δ	24-57 55 #20, & 2 #12	24-61 61 #20
28-42* 42 #16								

Δ Grounded to shell

SERVICE RATING

Service Rating	Test Voltage (Sea Level)	Test Voltage 50,000 Ft.	Test Voltage 70,000 Ft.	Test Voltage 110,000 Ft.
I	1500 AC-RMS	500 AC-RMS	375 AC-RMS	200 AC-RMS

Please note that the establishment of electrical safety factors is left entirely in the designer's hands, since he is in the best position to know what peak voltages, switching surges, transients, etc. can be expected in a particular circuit.

ORDERING INFORMATION—EUROPEAN STANDARDS

Aerospatiale Designation

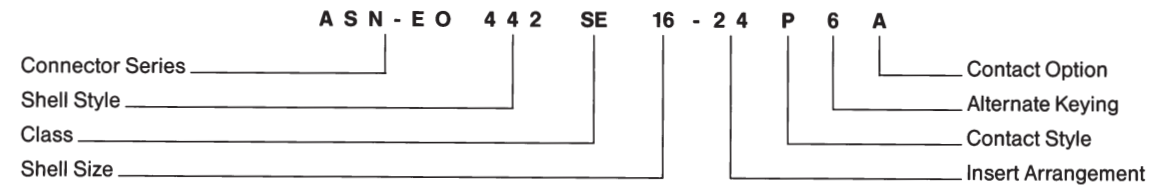

Shell Style

- 195*: Plug, Non-decoupling, accessory teeth per MIL-C-83723 III, Stainless steel
- 197*: Square Flange Receptacle, accessory teeth per MIL-C-83723 III, Stainless steel
- 320*: Plug, Non-decoupling, accessory teeth per MIL-C-83723 III, Aluminum
- 321*: Jam Nut Rec., accessory teeth per MIL-C83723 III, Aluminum
- 322*: Square Flange Rec., accessory teeth per MIL-C-83723 III, Aluminum
- 441: Plug, Non-decoupling, 360° accessory teeth per MS3155, Stainless steel
- 442: Plug, Non-decoupling, 360° accessory teeth per MS3155, with grounding spring, Stainless steel
- 443*: Square flange Receptacle, accessory teeth per MIL-C-83723 III, Stainless steel
- 444: Same as 443 with 360° accessory teeth per MS3155
- 451: Plug, Non-decoupling, 360° accessory teeth per MS3155
- 452: Plug, Non-decoupling, 360° accessory teeth per MS3155, with grounding spring, aluminum
- 453*: Square Flange Rec., 360° accessory teeth per MS3155, Aluminum
- 454: Same as 453 with 360° accessory teeth per MS3155

*Not active for new design

Class

- K: Stainless Steel, Firewall, 200°C
- KE: Stainless Steel, Firewall, 260°C
- R: Aluminum, Electroless Nickel Finish, 200°C
- RS: Aluminum Electroless Nickel Finish, 200°C, with grounding spring on plug
- S: Stainless Steel, Firewall, 200°C, with grounding spring on plug
- SE: Stainless Steel, Firewall, 260°C, with grounding spring on plug

Shell Size

8, 10, 12, 14, 16, 18, 20, 22, 24, 28

Insert Arrangement

See Chart (page 9)

Contact Style

P = Pin S = Socket

Alternate Keying

N = Normal, 6, 7, 8, 9 and Y

Contact Option

Omit = with Contacts

A = without Contacts

Note: Per ASN-E, #20 contacts with #18 crimpwell supplied standard when ordered with connectors.

ALTERNATE KEYING

ALTERNATE POLARITY
 KEYWAY ARRANGEMENTS
 View of front face of receptacle shell.
 Angles are counter clockwise from "N" keyway. For plug shell, the key locations are clockwise when viewed from front of plug.

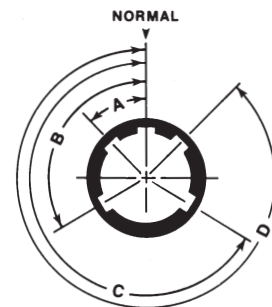

ESC 11 (ONLY)

Position	For Connectors Size 8 and 10				For Connectors Size 12, 14, 16, 18, 20, 22, 24, and 28			
	A	B	C	D	A	B	C	D
Normal	105°	140°	215°	265°	105°	140°	215°	265°
6	102°	132°	248°	320°	18°	149°	192°	259°
7	80°	118°	230°	312°	92°	152°	222°	342°
8	35°	140°	205°	275°	84°	152°	204°	334°
9	64°	155°	234°	304°	24°	135°	199°	240°
Y(10°)	25°	115°	220°	270°	98°	152°	268°	338°

*Not Available in Size 8 Connector

Position	For Connectors Size 14 thru 24			
	A	B	C	D
Normal	95	145	220	255
6	101	168	211	342
7	18	138	208	268
8	26	156	208	276
9	120	161	225	336

MIL-C-83723 HERMETIC CONNECTORS

PERFORMANCE CHARACTERISTICS

Thermal Shock (Unmated)	No damage detrimental to the operation of the connector occurs when subjected to 10 cycles of thermal shock from 0°C to 90°C and back to 0°C.	Air Leakage (Unmated)	Less than .01 micron per cubic feet per hour on application of 15 PSI pressure differential across the connector.
Physical Shock (Mated)	300 g's	Altitude Immersion (Mated)	After 3 cycles immersed in salt water with pressure reduced to 1 in. Hg. (75,000 ft. altitude) for 30 minutes and returned to atmospheric pressure. While connectors submerged insulation resistance should remain 1000 megohms minimum and support 1500 volts RMS applied without flashover or breakdown.
Moisture Resistance (Mated)	500 Megohms	High Potential Voltage Altitude (Unmated)	When tested in accordance with MIL-STD-202, Method 301, no flash-over or breakdown under simulated altitude conditions as shown:
Insulation Resistance High Temperature (Mated)	500 Megohms	Altitude	50,000/Service Rating I 500 AC-RMS 70,000 375 AC-RMS 110,000 200 AC-RMS
Corrosion (Unmated)	Comply with MIL-C-83723 Req.		
Temperature Life	Fully functional for 1000 hours at 200°C (392°F) ambient. Internal temperature 238°C (460°F)		

HERMETIC ORDERING INFORMATION

Military Designation

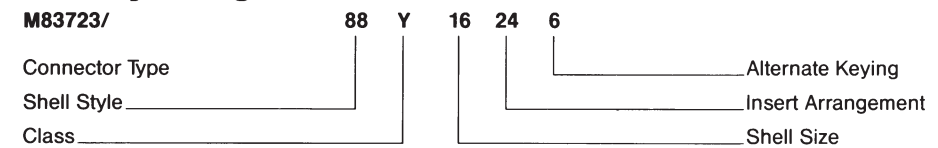

Shell Style

- 88—Square Flange Receptacle
- 89—D-Hole Mounted Receptacle
- 90—Solder Mounted Receptacle

Class

Y Stainless Steel

Shell Size

8, 10, 12, 14, 16, 18, 22

Insert Arrangements

See Chart (page 9).

Alternate Keying

N = Normal 6, 7, 8, 9 and Y* alternates

*Formerly 10 (see page 8).

Pyle Designation

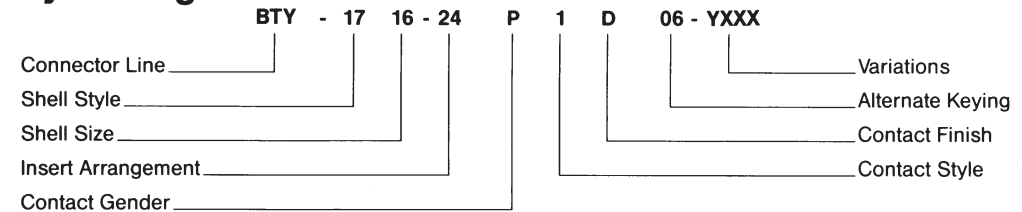

Connector Line

- BTY—Threaded Hermetic—'O' Ring Seal—Stainless Steel Shell
- BFY—Threaded Hermetic—Static/Dynamic Seal—Stainless Steel Shell
- BNY—Threaded Hermetic—Static/Dynamic Seal, Stainless Steel, Electrodeposited Nickel

Shell Style

- 17—Square Flange Receptacle
- 19—D-Hole Mounted Receptacle
- 14—Solder Mounted Receptacle

Shell Size

08, 10, 12, 14, 16, 18, 22

Insert Arrangements

See Chart (page 9).

Contact Gender

P = Pin

Contact Style

1 = Solderwell (Mil Spec. Type) 4 = Eyelet

Contact Finish

D = .000050 (per MIL-C-83723 III) gold

V = .000100 gold

Alternate Keying

(Omit for Normal) 06, 07, 08, 09 and 10 (see page 8).

Variations

Y144 260°C Capability (Euro Market)

Y163 200°C Capability (Euro Market)

Y186 260°C Capability per G.E. M50TF3564, Class B

Y188 200°C Capability per G.E. M50TF3564, Class A

Consult factory for other special variations.

HERMETIC CONNECTORS SPECIFICATIONS

HERMETIC FLANGE MOUNT RECEPTACLE MIL-C-83723/88 THREADED TYPE

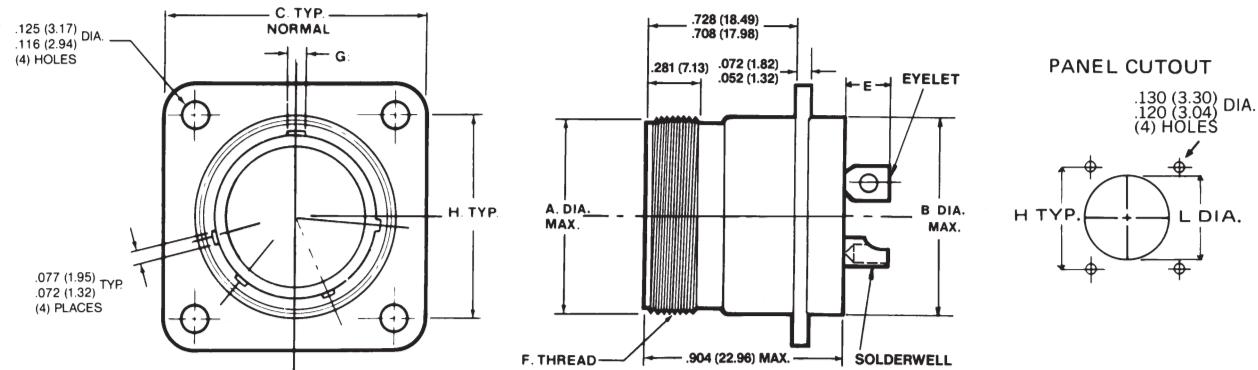

Shell Size	INCHES								
	A Dia. (Max.)	B Dia. (Max.)	C Dim. ±.010	E		F Coupling Thread UNEF-2A	G Dim. ±.003	H ±.005	L Dia. ±.005
				#20 Contacts	#12 & #16 Contacts				
08	.562	.500	.812	.194/.134	.224/.164	.562-24	.094	.594	.572
10	.696	.562	.937	.194/.134	.224/.164	.688-24	.094	.719	.706
12	.875	.750	1.031	.194/.134	.224/.164	.875-20	.094	.812	.885
14	.936	.812	1.125	.194/.134	.224/.164	.938-20	.094	.906	.946
16	1.062	.937	1.250	.194/.134	.224/.164	1.062-18	.125	.969	1.072
18	1.187	1.062	1.343	.194/.134	.224/.164	1.188-18	.125	1.062	1.197
22	1.437	1.312	1.562	.194/.134	.224/.164	1.438-18	.125	1.250	1.447

Shell Size	MILLIMETERS								
	A Dia. (Max.)	B Dia. (Max.)	C Dim. ±.25	E		G Dim. ±.08	H ±.13	L Dia. ±.13	
				#20 Contacts	#12 & #16 Contacts				
08	14.27	12.70	20.62	4.93/3.40	5.69/4.17	2.39	15.09	14.53	
10	17.68	14.27	23.80	4.93/3.40	5.69/4.17	2.39	18.26	17.93	
12	22.23	19.05	26.19	4.93/3.40	5.69/4.17	2.39	20.62	22.48	
14	23.77	20.62	28.58	4.93/3.40	5.69/4.17	2.39	23.01	24.03	
16	26.97	23.80	31.75	4.93/3.40	5.69/4.17	3.18	24.61	27.23	
18	30.15	26.97	34.11	4.93/3.40	5.69/4.17	3.18	26.91	30.40	
22	36.50	33.32	36.50	4.93/3.40	5.69/4.17	3.18	31.75	36.75	

ORDERING INFORMATION—EUROPEAN STANDARDS

AECMA Designation

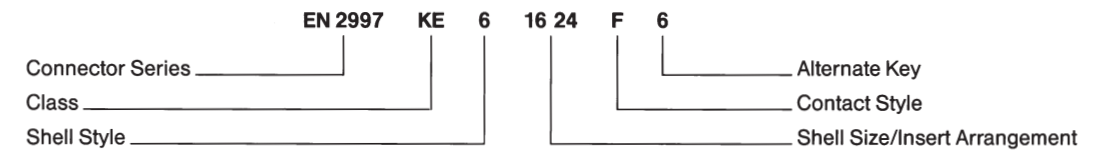

Connector Series

EN 2997 AECMA designation
NFL 54143 European designation

Class

STANDARD TEMPERATURE

R Aluminum, Electroless Nickel Plated (200°C)
RS Same as R with Grounding Spring on plug
W Aluminum, Olive Drab Cadmium Over Nickel (175°C)
WS Same as W with Grounding Spring on plug
K Stainless Steel Firewall (200°C)
S Same as K with Grounding Spring on plug
Y Stainless Steel Hermetic with Solderwell Contact (200°C)

HIGH TEMPERATURE (260°C)

KE Stainless Steel Firewall
SE Same as KE with Grounding Spring
YE Stainless Steel Hermetic with Solderwell Contact

Shell Style

0 Square Flange Receptacle
1 Solder Mount Receptacle (Hermetic Only)
6 Plug, Non-Decoupling
7 Jam Nut Receptacle

Shell Size

8, 10, 12, 14, 16, 18, 20, 24, 28

Insert Arrangement

See Chart (Page 9)

Contact Style

M = Standard pin, C=#20 pin with #18 crimpwell
A = Pin insert less contacts
F = Standard socket
D = #20 socket with #18 crimpwell
B = Socket insert less contacts

Alternate Keying

N=Normal, 6, 7, 8, 9 and Y

Society of British Aerospace Companies/Rolls Royce Standards

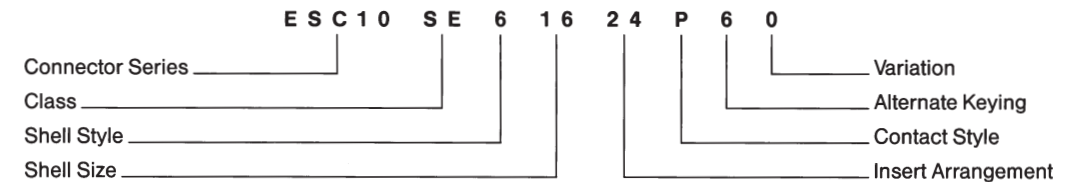

Connector Series

ESC 10 Basic High Temperature Connector
ESC 11 100% Scoop Proof-High Temperature Connector

Class

KE: Stainless Steel, Firewall (260°C)
SE: Stainless Steel, Firewall (260°C) with Grounding Spring
YE: Stainless Steel Hermetic (260°C)

Shell Style

0 Square Flange Receptacle with 360° accessory teeth per MS3155
1 Hermetic, Solder Mount
2 Hermetic, Square Flange
3 Hermetic, Jam Nut
6 Plug, Non-decoupling with 360° accessory teeth per MS3155

Shell Size

8, 10, 12, 14, 16, 18, 20, 22, 24, 28

Insert Arrangement

See Chart (page 9)

Contact Style

P = Pin S = Socket
(All connectors supplied w/o contacts except Shell Styles 1, 2, and 3)

Alternate Keying

N = Normal, 6, 7, 8, and 9 alternates

Variations

O = Basic Connector
Alphabetic identifiers as assigned
A = Lockwires holes on plug

ORDERING INFORMATION—EUROPEAN STANDARDS

Pyle Designation

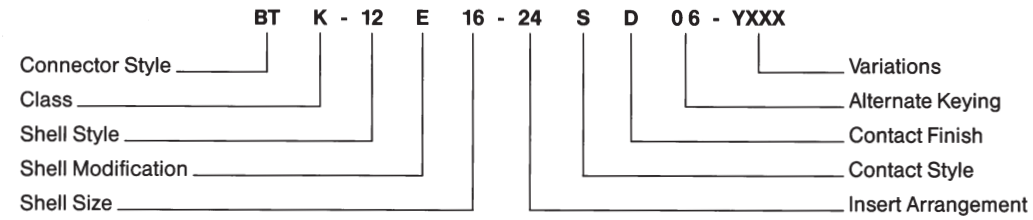

Style

- BT Threaded, 'O' Ring Seal (Std)
- BJ Threaded, Static/Dynamic Seal (Optional)

Class

- G Stainless Steel
- K Stainless Steel Firewall
- R Aluminum, Electroless Nickel Plated
- W Aluminum, Olive Drab Cadmium over Nickel

Shell Style

- 12 Non-Decoupling Plug
- 17 Square Flange Receptacle
- 19 Jam Nut Receptacle

Shell Modification

- E = 360° Accessory Teeth per MS3155
- F = 360° Accessory Teeth per MS3155 with Grounding Spring on plug

Shell Size

- 8, 10, 12, 14, 16, 18, 20, 22, 24, 28

Insert Arrangement

See Chart (page 9)

Contact Style

- P = Standard pin
- K = #20 pin with #18 crimpwell
- S = Standard socket
- L = #20 socket with #18 crimpwell

Contact Finish

- D = Gold per MIL-C-39029 (Special High Temperature Contact—See Chart page 19)
- E = Without Contacts per ESC 10

Alternate Keying

(Omit for Normal) 06, 07, 08, 09 and 10 alternates

Variations

- Y144 260°C Capability (Euro Market)
- Y163 200°C Capability (Euro Market)
- Y175 Superseded by Y144
- Y176 260°C per G.E. M50TF3564, Class B, No Accessory Teeth
- Y185 Superseded by Y163
- Y186 260°C Capability per G.E. M50TF3564 Class B
- Y188 200°C Capability per G.E. M50TF3564 Class A

Pyle Designation—ESC 11 Series

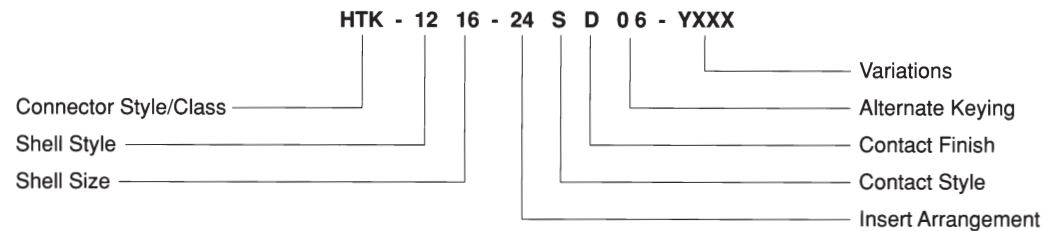

Style/Class

- HTK Standard ESC 11, Class K
- HNK Nickel Finish, Class K, Static/Dynamic Seal

Shell Style

- 12 Non-Decoupling Plug
- 17 Square Flange Receptacle

Shell Size

- 12, 14, 16, 18, 20, 22, 24

Insert Arrangement

See Chart (page 9)

Contact Style

- P = Pin
- S = Socket

Contact Finish

- D = Gold per MIL-C-39029 (optional) (Special High Temperature Contacts—See page 19)
- E = Without Contacts per ESC 11

Alternate Keying

(Omit for Normal) 06, 07, 08 and 09 Alternates—Not intermateable with ESC 10 (See page 8)

Variations

- Y144 260°C
- Y163 200°C
- Y186 260°C per GE M50TF3564, Class B
- Y188 200°C per GE M50TF3564, Class A

HERMETIC CONNECTORS SPECIFICATIONS

HERMETIC SOLDER MOUNT RECEPTACLE MIL-C-83723/90 THREADED TYPE

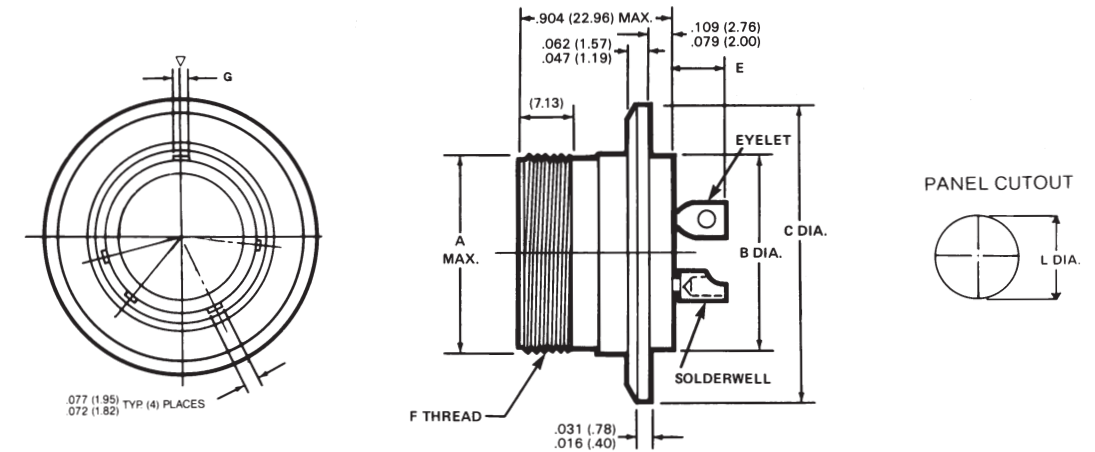

INCHES

Shell Size	A Dia. (Max.)	B Dia. (Max.)	C Dia. ±.010	E		F Coupling Thread UNEF-2A	G Dim. ±.003	L Dia. ±.005
				#20 Contacts	#12 & #16 Contacts			
08	.562	.500	.713	.194/.134	.224/.164	.562-24	.094	.510
10	.696	.562	.840	.194/.134	.224/.164	.688-24	.094	.572
12	.875	.750	1.045	.194/.134	.224/.164	.875-20	.094	.760
14	.936	.812	1.090	.194/.134	.224/.164	.938-20	.094	.822
16	1.062	.937	1.210	.194/.134	.224/.164	1.062-18	.125	.947
18	1.187	1.062	1.340	.194/.134	.224/.164	1.188-18	.125	1.072
22	1.437	1.312	1.562	.194/.134	.224/.164	1.438-18	.125	1.322

MILLIMETERS

Shell Size	A Dia. (Max.)	B Dia. (Max.)	C Dim. ±.25	E		G Dim. ±.08	L Dia. ±.13
				#20 Contacts	#12 & #16 Contacts		
08	14.27	12.70	18.11	4.93/3.40	5.69/4.17	2.39	12.95
10	17.68	14.27	21.34	4.93/3.40	5.69/4.17	2.39	14.53
12	22.23	19.05	26.54	4.93/3.40	5.69/4.17	2.39	19.30
14	23.77	20.62	27.69	4.93/3.40	5.69/4.17	2.39	20.88
16	26.97	23.80	30.73	4.93/3.40	5.69/4.17	3.18	24.05
18	30.15	26.97	34.04	4.93/3.40	5.69/4.17	3.18	27.23
22	36.50	33.32	39.67	4.93/3.40	5.69/4.17	3.18	33.58

HERMETIC CONNECTORS SPECIFICATIONS

HERMETIC D-HOLE MOUNT RECEPTACLE MIL-C-83723/89 THREADED TYPE

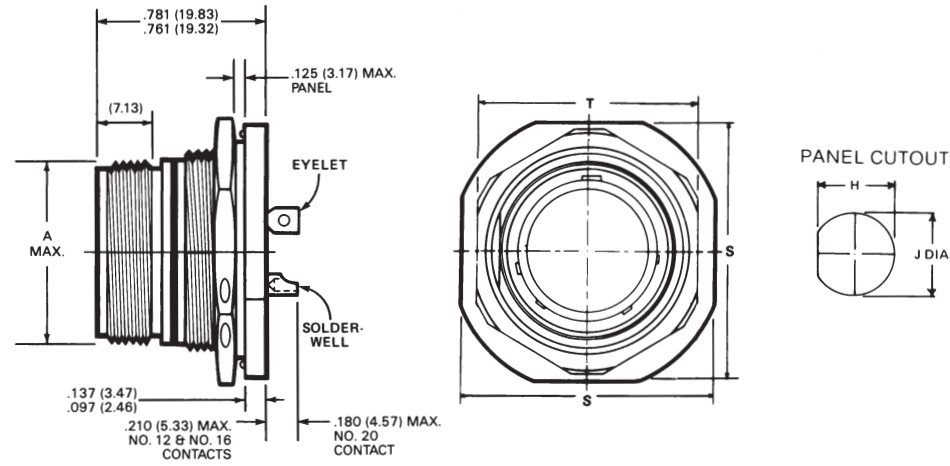

Shell Size	INCHES					MILLIMETERS				
	A Dia. (Max.)	H Flats ±.005	J Dia. ±.005	S Flats (Max.)	T Hex (Max.)	A Dia. (Max.)	H Flats ±.13	J Dia. ±.13	S Flats (Max.)	T Hex (Max.)
08	.562	.605	.635	.980	.828	14.27	15.37	16.13	24.89	21.03
10	.696	.730	.760	1.104	.953	17.68	18.54	19.30	28.04	24.21
12	.875	.917	.947	1.291	1.140	22.23	23.29	24.05	32.79	28.96
14	.936	.980	1.010	1.391	1.205	23.77	24.89	25.65	35.33	30.61
16	1.062	1.105	1.135	1.516	1.329	26.97	28.07	28.83	38.51	33.76
18	1.187	1.225	1.260	1.641	1.455	30.15	31.12	32.00	41.68	36.96
22	1.437	1.475	1.510	1.954	1.705	36.47	37.47	38.35	49.63	43.31

TOOLS

CONTACT SIZE	Crimp Tool	Adjustable Turret	Checking Gauge For M22520/1-01 Crimping Tool	Insertion/Removal Tools
20	M22520/1-01 Pyle-National TP-201354	M22520/1-02 Pyle-National TP-201355	M22520/3 Pyle-National TP-201356	M81969/14-11 Pyle-National TP-201343-20-BA
16	M22520/1-01 Pyle-National TP-201354	M22520/1-02 Pyle-National TP-201355	M22520/3 Pyle-National TP-201356	M81969/14-03 Pyle-National TP-201343-16-BA
12	M22520/1-01 Pyle-National TP-201354	M22520/1-02 Pyle-National TP-201355	M22520/3 Pyle-National TP-201356	M81969/14-04 Pyle-National TP-201343-12-BA
8 Twinax*	-	-	-	TP-201391-08

* See Bulletin MS-103 for details.

ORDERING INFORMATION FOR BOEING COMPANY

Boeing Designation (BACC63BR/BT Firewall)

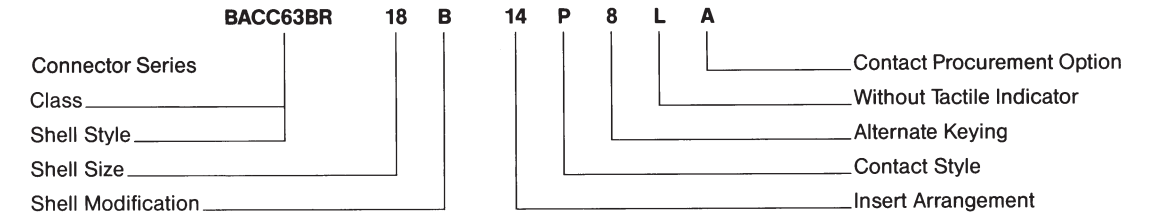

Shell Style
 BR—Non-Decoupling Plug, Firewall
 BT—Square Flange Receptacle, Firewall

Boeing Specification Qualified Shell Sizes
 12, 14, 16, 18, 20, 22, 24, 28

Boeing Specification Qualified Insert Arrangements
 12-03, 14-04, 14-07, 16-10, 18-14, 20-16, 22-19, 24-30, 28-42

Shell Modifications
 B = 360° Accessory Teeth per MS3155
 D = 360° Accessory Teeth per MS3155 with Grounding Spring on plug
 -- = Accessory Teeth per MIL-C-83723 III

Contact Style
 P = Pin S = Socket
 (Gold Plate per MIL-C-39029)

Alternate Keying
 N = Normal, 6, 7, 8, 9 and 10 (see page 8).

Contact Procurement Option
 A = Without Contacts and Seal Plugs (Letter 'A' to be used on Purchase Orders only and will not appear on Connector as part of Connector Part Number)

Pyle Designation

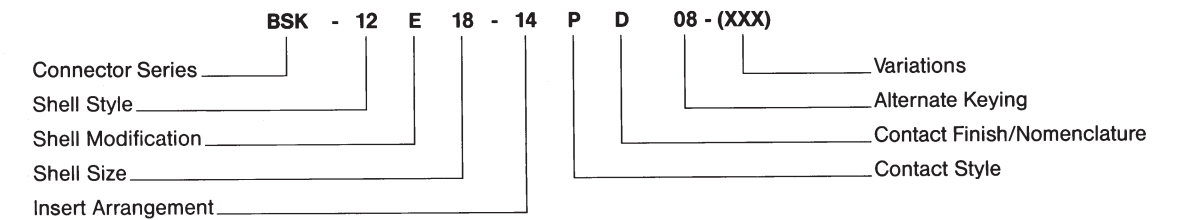

Connector Series
 BSK—Threaded, Stainless Steel Firewall Qualified to Boeing Co. BACC63BR/BT Specifications ("O" Ring Designation)

Shell Style
 12—Threaded Non-Decoupling Plug
 17—Square Flange Receptacle

Shell Modification
 E = 360° Accessory Teeth per MS3155 plug & receptacle
 F = 360° Accessory Teeth per MS3155 with Grounding Spring on plug only
 (Blank) = Accessory Teeth per MIL-C-83723 III

Shell Size
 12, 14, 16, 18, 20, 22, 24, 28

Insert Arrangements
 See Chart (page 9).

Contact Style
 P = Pin S = Socket

Contact Finish/Nomenclature
 D = Gold per MIL-C-39029
 E = Without Contacts

Alternate Keying
 (Omit for Normal) 06, 07, 08, 09 and 10 (see page 8).

Variations
 Y126—Contact Marking per MIL-C-83723/33 & 34 (Required with BACC63BR/BT Series)

Service Class - Military and Pyle

- A Non-Corrosive Anodized Aluminum
- G Corrosion Resistant Stainless Steel
- K Corrosion Resistant Stainless Steel, Firewall Capability
- R Conductive Finish Electroless Nickel Plated Aluminum
- W Olive Drab, Cadmium over Nickel Plated Aluminum

ORDERING INFORMATION FOR THREADED/BAYONET SERIES

Military Designation

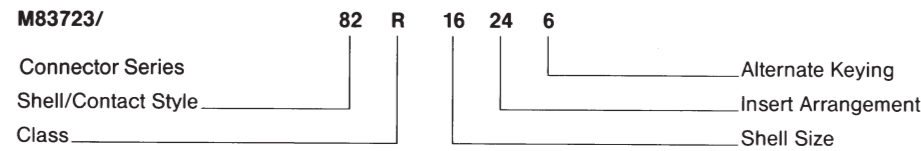

Shell/Contact Style

- 71—Bayonet, Square Flange Receptacle, Sockets
- 72—Bayonet, Square Flange Receptacle, Pins
- 73—Bayonet, Jam Nut Receptacle, Sockets
- 74—Bayonet, Jam Nut Receptacle, Pins
- 75—Bayonet, Plug, Sockets
- 76—Bayonet, Plug, Pins
- 82—Threaded, Square Flange Receptacle, Sockets
- 83—Threaded, Square Flange Receptacle, Pins
- 84—Threaded, Jam Nut Receptacle, Sockets
- 85—Threaded, Jam Nut Receptacle, Pins
- 86—Threaded, Straight Plug, Sockets
- 87—Threaded, Straight Plug, Pins
- 95—Threaded, Non-Decoupling Plug, Sockets
- 96—Threaded, Non-Decoupling Plug, Pins

Class

- A Aluminum, Black Anodized, Non-Conductive
- G Stainless Steel
- K Stainless Steel Firewall
- R Aluminum, Electroless Nickel Plated
- W Aluminum, Olive Drab Cadmium

Shell Size

8, 10, 12, 14, 16, 18, 20, 22, 24

Insert Arrangement

See Chart (page 9).

Alternate Keying

N=Normal, 6, 7, 8, 9 and Y* alternates.
 *Formerly 10 (see page 8).

Pyle Designation

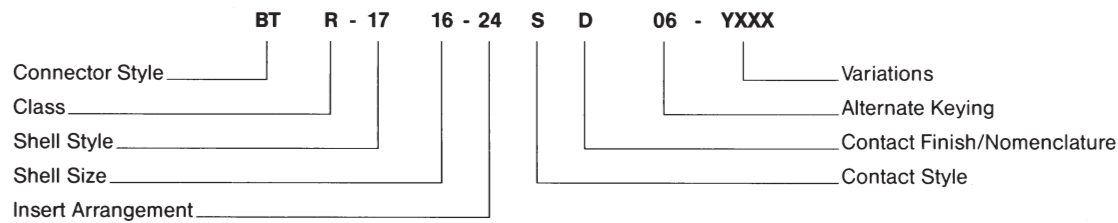

Connector Style

Standard Design

- BT—Threaded—'O' ring seal in receptacle
- BY—Bayonet—'O' ring seal in receptacle

Alternate Design

- BJ—Threaded, Stainless Steel—
 Static/Dynamic Seal in receptacle
- BN—Same as BJ except Electrodeposited
 Nickel Plate

Class

- A Aluminum, Black Anodized, Non-Conductive
- R Aluminum, Electroless Nickel Plated
- W Aluminum, Olive Drab Cadmium Over Nickel
- G Stainless Steel
- K Stainless Steel Firewall

Shell Style

- 10—Bayonet Plug
- 11—Threaded Straight Plug
- 12—Threaded Non-Decoupling Plug
- 17—Square Flange Receptacle
- 19—Jam Nut Receptacle

Shell Size

8, 10, 12, 14, 16 18, 20 22, 24, 28

Insert Arrangements

See Chart (page 9).

Contact Style (Crimp)

P = Pin S = Socket

Contact Finish/Nomenclature

D = gold per MIL-C-39029
 E = without contacts

Alternate Keying

(Omit for normal) 06, 07, 08, 09 and
 10 alternate (see page 8).

Variations

Consult factory for special variations.

CONTACT INFORMATION

Standard Contacts and Seal Plugs

CONTACT SIZE	SPEC NUMBER	SUPERSEDED NUMBER	PIN PART NUMBERS	
			PYLE NUMBER	
			HIGH PERFORMANCE*	STANDARD CONTACT
20	M39029/4-110	M83723-33B20	BA-4020-36LD	BA-4020-96LD
16	M39029/4-111	M83723-33B16	BA-4016-36LD	BA-4016-96LD
12	M39029/4-113	M83723-33B12	BA-4012-36LD	BA-4012-96LD

*Recommended for high vibration areas.

CONTACT SIZE	PIN COLOR BANDS		
	1st BAND	2nd BAND	3rd BAND
20	Brown	Brown	Black
16	Brown	Brown	Brown
12	Brown	Brown	Orange

COLOR BANDS

Pin

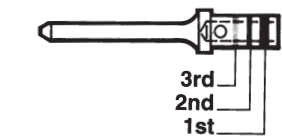

CONTACT SIZE	SPEC NUMBER	SUPERSEDED NUMBER	SOCKETS PART NUMBERS	
			PYLE NUMBER	
			HIGH PERFORMANCE*	STANDARD CONTACT
20	M39029/5-115	M83723-34B20	BA-4120-36LD	BA-4120-96LD
16	M39029/5-116	M83723-34B16	BA-4116-36LD	BA-4116-96LD
12	M39029/5-118	M83723-34B12	BA-4112-36LD	BA-4112-96LD

*Recommended for high vibration areas. Sockets feature 4 tine construction with supporting spring bands.

CONTACT SIZE	SOCKET COLOR BANDS		
	1st BAND	2nd BAND	3rd BAND
20	Brown	Brown	Green
16	Brown	Brown	Blue
12	Brown	Brown	Gray

COLOR BANDS

Socket

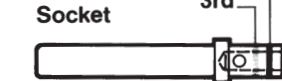

Seal Plugs

CONTACT SIZE	MS NUMBER	PYLE NUMBER
20	MS27488-20	BA-4020-59P
16	MS27488-16	BA-4016-59P
12	MS27488-12	BA-4012-59P

Standard Contact Rating

CRIMP CONTACT SIZE	Test Current Standard	CRIMP WELL DATA	
		Well Diameter	Min. Well Depth
20	7.5	.049	.157
16	13.0	0.067	.250
12	23.0	.100	.250

CONTACT INFORMATION

SHIELDED CONTACTS

CONTACT SIZE	PIN	CABLE ACCOMMODATION	SOCKET
#8 Twinax	BA-46T08-LD	M17/176-00002	BA-47T08-LD
#8 Twinax	BA-46TA08-LD	PAN 6421 or JN1060ZB002	BA-47TA08-LD

THERMOCOUPLE CONTACTS

CONTACT SIZE	MATERIAL	PIN PART NUMBER	SOCKET NUMBER
20	Chromel	BT-4020-10P	BT-4120-10P
20	Alumel	BT-4020-10R	BT-4120-10R
16	Chromel	BT-4016-10P	BT-4116-10P
16	Alumel	BT-4016-10R	BT-4116-10R

CONTACT SIZE	MATERIAL	PIN COLOR BANDS		
		1st	2nd	3rd
20	Chromel	Brown	Orange	Green
20	Alumel	Brown	Orange	Yellow
16	Chromel	Green	Brown	Violet
16	Alumel	Green	Brown	Blue

CONTACT SIZE	MATERIAL	SOCKET COLOR BANDS		
		1st	2nd	3rd
20	Chromel	Brown	Yellow	Brown
20	Alumel	Brown	Yellow	Black
16	Chromel	Green	Red	Red
16	Alumel	Green	Red	Brown

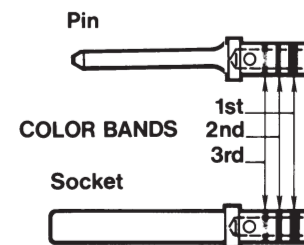

Standard and High Temperature Wire Sealing Diameters/Stripping Length

CONTACT SIZE	WIRE SIZE (AWG)	FINISHED WIRE OUTSIDE				STRIPPING LENGTH	
		MINIMUM		MAXIMUM		MINIMUM INCHES	MAXIMUM INCHES
		INCH	METRIC	INCH	METRIC		
20	24, 22, 20	.033	.085	.083	2.1	.140	.202
16	20, 18, 16	.047	1.2	.106	2.7	.218	.280
12	14, 12	.075	1.9	.157	4	.218	.280

MIL-C-83723 SERIES III

Pyle-National has a long history as a quality supplier of connectors for demanding environments. Proven technology and traditional Pyle attention to design details are incorporated into all styles and classes of the Pyle-National MIL-C-83723 Series III connectors.

In our M83723/95, 96 Series (featured on page 2), Pyle offers the user a major performance advantage through a unique threaded coupling mechanism that features a greater resistance to decoupling than to coupling. This device eliminates the need for safety wiring and tends to couple during vibration – thus offering the user added assurance and a margin of safety.

MIL-C-83723 SERIES III-HIGH TEMPERATURE

Using MIL-C-83723 Series III design concepts, Pyle-National has also developed a series of High Temperature firewall connectors (featured on page 2), that are capable of operation at 260° C/500° F. A 100% scoop-proof version of the high temperature connector is also available under specification ESC 11/Pyle HTK Series. In addition, this connector series incorporates a unique sealing grommet that is capable of sealing on standard diameter wire as well as Kapton wire of reduced diameter.

This connector was developed for the higher operating temperatures inherent in today's newest high performance aircraft and aircraft engines. These connectors meet the performance requirements of the following specifications:

- Aerospatiale: ASN-EO44X Class KE/SE
- General Electric: M50TF3564
- European: AECMA EN2997
- Rolls Royce/SBAC:ESC 10/ESC 11

It is because of our history and proven design capability that we are able to offer connectors in environmental, firewall and hermetic classes that exceed even the most stringent specification requirements.

PERFORMANCE CHARACTERISTICS

Operating Temperature Data
Std: -85°F (-65°C) to 392°F (200°C).
Class K types meet fireproof test per MIL-C-83723 2000°F (1093°C).
High Temperature Series: Operates at 500°F (260°C).

Altitude
Sea Level to 110,000 feet.

Voltage Breakdown Rating
Service Rating I

Sea Level	1,500
50,000 feet	500
70,000 feet	375
110,000 feet	200

Current Rating
Size 20 contacts
7.5 amperes maximum
Size 16 contacts
13.0 amperes maximum
Size 12 contacts
23 amperes maximum

Contact Retention Strength
Exceeds MIL-C-83723 requirements.
Connector Durability
500 cycles per MIL-C-83723 for threaded coupling.
500 cycles per General Electric M50TF2321 for non-decoupling.

Humidity
To 98% relative humidity, including condensation.
Exposure Freezing rain.
Non-Decoupling
Exceeds requirements of MIL-C-83723/95 and 96.
Non-decoupling feature tends to tighten connectors under vibration.

Vibration
Meets MIL-C-83723 of 41.7G's for 16 hours.
Boeing BACC63BR/BT for 36 hours.
General Electric vibration specifications.
M50TF2321 and M50TF2238 for 36 hours, which includes:

TEMPERATURE	G	TIME
EXTREMES	LEVEL	LENGTH
Room Temp.	60 G's	12 hours
-65F ± 5°F	60 G's	4 hours (each axis)
		12 hours (each axis)
350 ± 5°F	60 G's	4 hours (each axis)
		12 hours (each axis)

MIL-C-83723

SERIES III CONNECTORS

MIL-C-83723 SERIES III— THREADED STYLE

- Patented non-decoupling device (torque differential)
- Metal to metal bottoming
- Unique sealing grommet accepts wide range of wire diameters

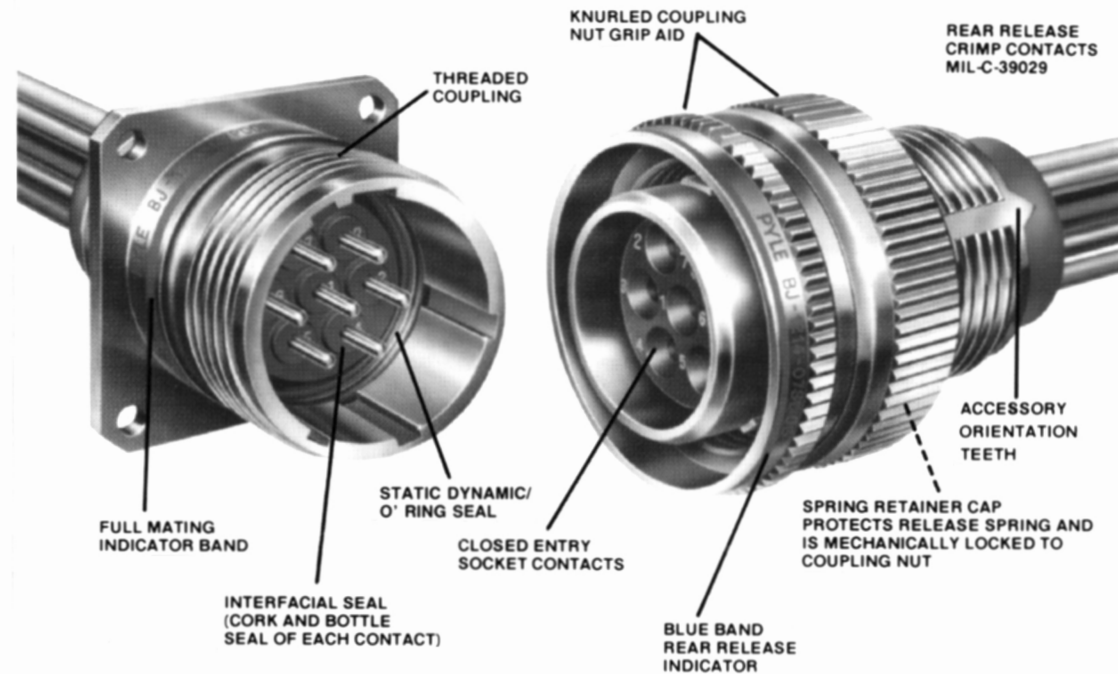

MIL-C-83723 SERIES III— HIGH- TEMPERATURE STYLE

- High temperature materials
- High temperature contacts
- Improved metal to metal bottoming design
- Unique sealing grommet accepts wide range of wire diameters
- Improved 360° accessory orientation teeth provide greater performance under vibration
- Patented non-decoupling device (torque differential)
- Improved shell to shell conductivity with optional grounding spring

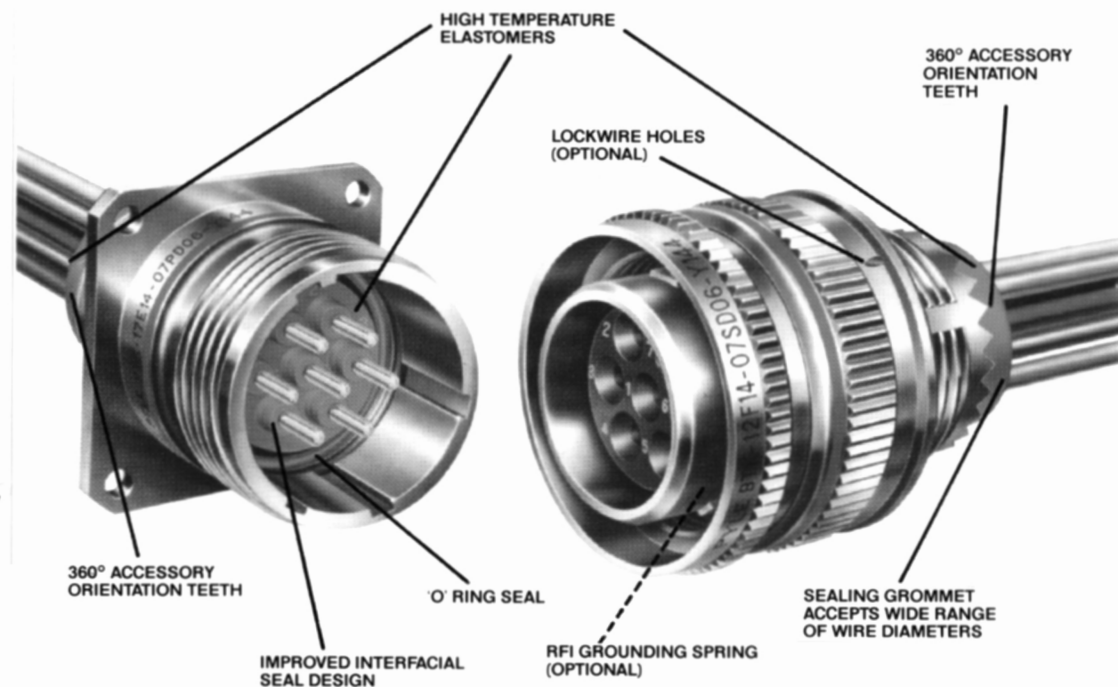

CONTACT INFORMATION—EUROPEAN SPECIFICATION

Standard Power Contacts

CONTACT SIZE	CONTACT PIN PART NUMBER		COLOR BANDS			SOCKET PART NUMBER	
	PYLE	EN3155	1st	2nd	DOT	PYLE	EN3155
20	BA-4020-36LD-Y165	EN3155-002M2020	Red	Red	—	BA-4120-36LD-Y165	EN3155-003F2020
20/18*	BA-402018-36LD-Y165	EN3155-002M2018	Red	Violet	—	BA-412018-36LD-Y165	EN3155-003F2018
16	BA-4016-36LD-Y165	EN3155-002M1616	Blue	Blue	—	BA-4116-36LD-Y165	EN3155-003F1616
12	BA-4012-36LD-Y165	EN3155-002M1212	Yellow	Yellow	—	BA-4112-36LD-Y165	EN3155-003F1212

High Temperature Contacts

CONTACT SIZE	PIN PART NUMBER			COLOR BANDS		
	PYLE	ESC30	EN3155	1st	2nd	DOT
20	BA-4020-50LD	ESC30-P20BC	EN3155-004M2020	Red	Red	White
20/18*	BA-402018-50LD	—	EN3155-004M2018	Red	Violet	White
16	BA-4016-50LD	ESC30-P16BC	EN3155-004M1616	Blue	Blue	White
12	BA-4012-50LD	ESC30-P12BC	EN3155-004M1212	Yellow	Yellow	White

CONTACT SIZE	SOCKET PART NUMBER			COLOR BANDS		
	PYLE	ESC30	EN3155	1st	2nd	DOT
20	BA-4120-50LD	ESC30-S20BC	EN3155-005M2020	Red	Red	White
20/18*	BA-412018-50LD	—	EN3155-005M2018	Red	Violet	White
16	BA-4116-50LD	ESC30-S16BC	EN3155-005M1616	Blue	Blue	White
12	BA-4112-50LD	ESC30-S12BC	EN3155-005M1212	Yellow	Yellow	White

Thermocouple Contacts

CONTACT SIZE	MATERIAL	PIN PART NUMBER		COLOR BANDS			SOCKET PART NUMBER	
		PYLE	ESC30	1st	2nd	DOT	PYLE	ESC30
20	Chromel	BT-4020-10P-Y165	ESC30-P20NC	Red	Red	Yellow	BT-4120-10P-Y165	ESC30-S20NC
20	Alumel	BT-4020-10R-Y165	ESC30-P20NA	Red	Red	Black	BT-4120-10R-Y165	ESC30-S20NA
20/18*	Chromel	BT-402018-10P-Y165	—	Red	Violet	Yellow	BT-412018-10P-Y165	—
20/18*	Alumel	BT-402018-10R-Y165	—	Red	Violet	Black	BT-412018-10R-Y165	—
16	Chromel	BT-4016-10P-Y165	ESC30-P16NC	Blue	Blue	Yellow	BT-4116-10P-Y165	ESC30-S16NC
16	Alumel	BT-4016-10R-Y165	ESC30-P16NA	Blue	Blue	Black	BT-4116-10R-Y165	ESC30-S16NA

* #20 contacts with #18 crimpwell

High Temperature Seal Plug

CONTACT SIZE	PYLE	COLOR BAND
20	BT-4020-60P	RED
16	BT-4016-60P	BLUE
12	BT-4012-60P	YELLOW

Band 1: Color-contact size

Band 2: Color-AWG Wire

Dot: Identification marking — High Temperature/Thermal couple contacts

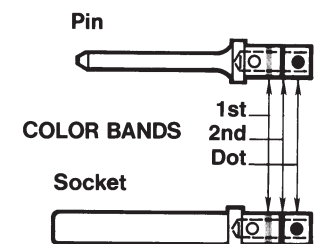

X-ON Electronics

Largest Supplier of Electrical and Electronic Components

Click to view similar products for [amphenol manufacturer](#):

Other Similar products are found below :

[CTV06RW-11-2JB-LC](#) [CTV06RGQF-17-52P](#) [CTVPS00RGF-23-6P-LC](#) [GC835TY2S](#) [MS27473P14B18S](#) [CTVS06RF-25-46PB-LC](#)
[GTC030-40-68SZ-025-RDS-LC](#) [ACC02E28-51S-003-B30-LC](#) [TV06RL-13-35AD](#) [TV06RL-13-98BD](#) [TV06RL-13-35SD-LC](#) [TV06RL-13-35SD](#) [TV06RL-13-98SD-LC](#) [TV06RL-13-98SD](#) [TVP00RW-23-53AD](#) [100-007-213-002-001](#) [FSPP-103-00-004](#) [360031](#) [TV06RW-25-90AE](#)
[97-3108B16S-5PW-417](#) [PT06J20-24SW](#) [97-3108B16S-5PY-417](#) [CS-DSDMDB37MF-025](#) [97-3108B16S-5PZ-417](#) [TV06RW-25-46AE](#) [CF-5A9013-04N](#) [CF-6A4615-06N](#) [GTC02R32-17S-025-RDS](#) [GTC02R32-17S-025-RDS-LC](#) [GTC02R32-17S-025-LC](#) [MBS-21C-EA00P](#)
[PT06SE-24-61P\(LC\)](#) [GTC07R-20-24P-023](#) [BT-4116-10RD-Y70](#) [SP28W1F](#) [GTC06-22-13SW](#) [GTC06-22-13SY](#) [GTS06G-36-10S](#)
[GTC06-22-13S-025-B30-LC](#) [GTC06-22-13SW-025-LC](#) [GTC06-22-13SX-025-B30](#) [GTC06-22-13SZ-025](#) [GTC06-22-13SZ-025-LC](#)
[GTC06-22-13S-025-LC](#) [GTC06-22-13SW-025-B30](#) [GTC06-22-13SW-025-B30-LC](#) [GTC06-22-13SX-025-B30-LC](#) [GTC06-22-13SX-025-LC](#)
[GTC06-22-13SY-025-B30](#) [GTC06-22-13SY-025-B30-LC](#)