

SURFACE FOR COLOUR STRIPE (see note 3)

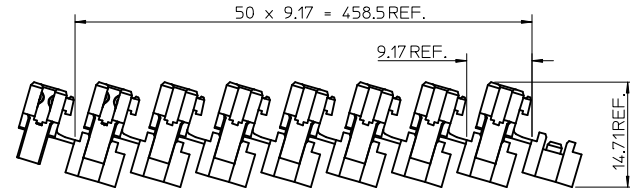

SHIPPING ARRANGEMENT

CCT	*A*	*B*
3	5.0	9.875
4	7.5	12.375
5	10.0	14.875
6	12.5	17.375
7	15.0	19.875
8	17.5	22.375
9	20.0	24.875
10	22.5	27.375
11	25.0	29.875
12	27.5	32.375
13	30.0	34.875
14	32.5	37.375
15	35.0	39.875
16	37.5	42.375
17	40.0	44.875
18	42.5	47.375
19	45.0	49.875
20	47.5	52.375

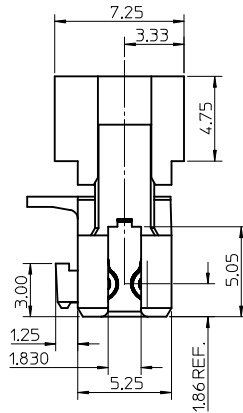
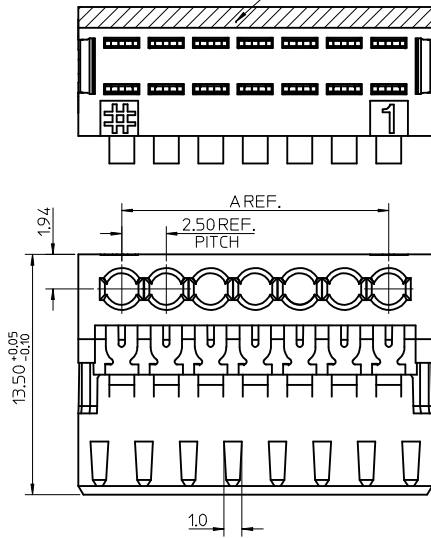
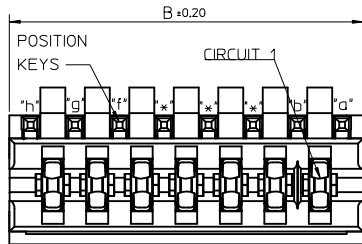

NOTES:

- REFER TO PRODUCT SPECIFICATION: PS-99020-0040.
- MATERIAL: HOUSING - NYLON PA6  
UL94-V0, COLOUR: NATURAL (WHITE).  
TERMINAL: PHOSPHOR BRONZE 0.30 REF. THICK - PLATING HOT TIN DIP.
- COLOUR STRIPE IS OPTIONAL. AVAILABLE IN THE FOLLOWING COLOURS: RED, GREEN, BLUE, PURPLE  
( **BOLD** SIGNIFIES CUSTOMER SPECIFIC CONFIGURATION).
- REFER TO PACKAGING SPEC (PK-90871-001)
- REFER TO APPLICATION SPEC (AS-99033-0008)

OPTIONAL PART FEATURES

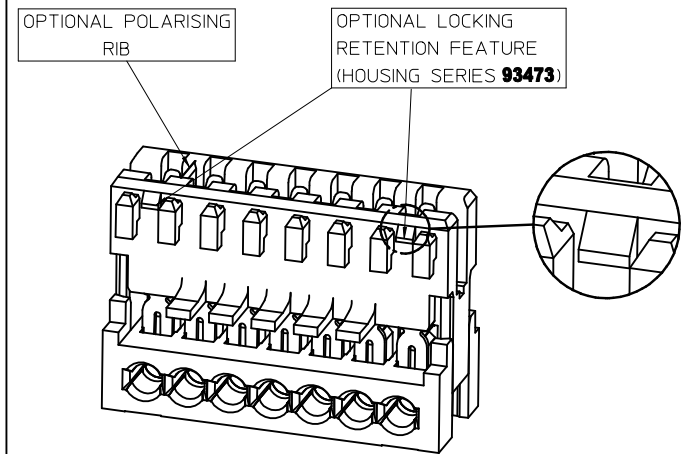

SEE SUBSEQUENT SHEETS FOR RELEVANT PART NUMBERS.  
\*LOCKING RETENTION FEATURE AVAILABLE **FIRST** AND **LAST** CIRCUIT ONLY  
SMALLEST CIRCUIT SIZE AVAILABLE WITH LOCKING RETENTION FEATURE IS 5 CKT

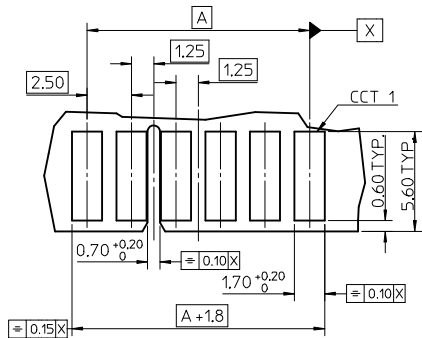

- PCB LAYOUT FOR 6CCT CONNECTOR  
(WITH OPTIONAL POSITIONAL RIB SLOT BETWEEN CCT 4 & 5)  
- RECOMMENDED PCB THICKNESS 1.5±0.14

<p>DOC. MAINTENANCE EC NO: IPG2016-0963 DRAWN: J MURPHY 2016/01/05 CHKD: APPR: S HANAHAN 2016/01/20</p>	QUALITY SYMBOLS	GENERAL TOLERANCES (UNLESS SPECIFIED)	DIMENSION STYLE	SCALE	DESIGN UNITS	THIRD ANGLE PROJECTION																										
	<p>▽=0 ▽=0</p>	<table border="1"> <thead> <tr> <th></th> <th>mm</th> <th>INCH</th> </tr> </thead> <tbody> <tr><td>4 PLACES</td><td>± ---</td><td>± ---</td></tr> <tr><td>3 PLACES</td><td>± 0.05</td><td>± ---</td></tr> <tr><td>2 PLACES</td><td>± 0.10</td><td>± ---</td></tr> <tr><td>1 PLACE</td><td>± 0.2</td><td>± ---</td></tr> <tr><td>0 PLACE</td><td>±</td><td>±</td></tr> </tbody> </table>		mm	INCH	4 PLACES	± ---	± ---	3 PLACES	± 0.05	± ---	2 PLACES	± 0.10	± ---	1 PLACE	± 0.2	± ---	0 PLACE	±	±	<table border="1"> <thead> <tr> <th>MM ONLY</th> <th>DATE</th> </tr> </thead> <tbody> <tr><td>DRAWN BY</td><td>2004/02/12</td></tr> <tr><td>CHECKED BY</td><td>2004/02/13</td></tr> <tr><td>APPROVED BY</td><td>2004/02/16</td></tr> </tbody> </table>	MM ONLY	DATE	DRAWN BY	2004/02/12	CHECKED BY	2004/02/13	APPROVED BY	2004/02/16	5:1	METRIC	
		mm	INCH																													
	4 PLACES	± ---	± ---																													
3 PLACES	± 0.05	± ---																														
2 PLACES	± 0.10	± ---																														
1 PLACE	± 0.2	± ---																														
0 PLACE	±	±																														
MM ONLY	DATE																															
DRAWN BY	2004/02/12																															
CHECKED BY	2004/02/13																															
APPROVED BY	2004/02/16																															
<p>ANGULAR ±1/2°</p>	<p>DRAFT WHERE APPLICABLE MUST REMAIN WITHIN DIMENSIONS</p>	<p>SEE SHEETS 2-10</p>	<p>APPLI-MATE 2.5 FEMALE (MATL: NYLON PA6)</p>		<p>SHEET NO. 1 OF 10</p>																											
<p>SIZE A2</p>	<p>THIS DRAWING CONTAINS INFORMATION THAT IS PROPRIETARY TO MOLEX INCORPORATED AND SHOULD NOT BE USED WITHOUT WRITTEN PERMISSION</p>																															

MOLEX PART NO.	MOLEX HOUSING NO.	TERMINAL VOID POSITION	REMOVED POSITION KEYS	CONFIGURATION (SEE NOTES)	END WALLS		POLARIZING RIB	COLOUR STRIPE
					FIRST	LAST		
91716-0001	91715-0003	NONE	NONE		OPEN	OPEN	NONE	NONE
91716-0002	91715-0003	NONE	a d		OPEN	OPEN	NONE	RED
91716-0013	91715-0003	NONE	a		OPEN	OPEN	NONE	NONE
91716-0014	91715-0003	NONE	b		OPEN	OPEN	NONE	NONE
91716-0015	91715-0003	NONE	c		OPEN	OPEN	NONE	NONE
91716-0016	91715-0003	NONE	d		OPEN	OPEN	NONE	NONE
91716-0017	91715-0003	NONE	b d		OPEN	OPEN	NONE	NONE
91716-0018	91715-0003	NONE	a c		OPEN	OPEN	NONE	NONE
91716-0019	91715-0003	NONE	a d		OPEN	OPEN	NONE	NONE
91716-0020	91715-0003	NONE	a b		OPEN	OPEN	NONE	NONE
91716-0021	91715-0003	NONE	b c		OPEN	OPEN	NONE	NONE
91716-0022	91715-0003	NONE	c d		OPEN	OPEN	NONE	NONE
91716-0023	91715-0003	<b>CKT 2</b>	b d		OPEN	OPEN	NONE	NONE
91716-0024	91715-0003	<b>CKT 3</b>	c		OPEN	OPEN	NONE	BLUE
91716-0034	91715-0103	NONE	NONE		OPEN	OPEN	<b>BETWEEN CKT 1&amp;2</b>	NONE
91716-0041	91715-0203	NONE	NONE		OPEN	OPEN	<b>BETWEEN CKT 2&amp;3</b>	NONE
91716-0042	91715-0003	<b>CKT 1</b>	NONE		OPEN	OPEN	NONE	NONE
91716-0043	91715-0003	<b>CKT 1</b>	c		OPEN	OPEN	NONE	NONE
91716-0044	91715-0003	NONE	b d		OPEN	OPEN	NONE	BLUE
91716-0045	91715-0003	NONE	b		OPEN	OPEN	NONE	BLUE
91716-0046	91715-0003	<b>CKT 1</b>	d		OPEN	OPEN	NONE	NONE
91716-0047	91715-0003	NONE	b d		OPEN	OPEN	NONE	RED
91716-0048	91715-0003	NONE	b c d		OPEN	OPEN	NONE	NONE
91716-0049	91715-0003	NONE	c		OPEN	OPEN	NONE	PURPLE
91716-0050	91715-9903	NONE	NONE		OPEN	<b>NARROW</b>	NONE	NONE

3 CIRCUIT (cont'd)								
MOLEX PART NO.	MOLEX HOUSING NO.	TERMINAL VOID POSITION	REMOVED POSITION KEYS	CONFIGURATION (SEE NOTES)	END WALLS		POLARIZING RIB	COLOUR STRIPE
					FIRST	LAST		
91716-0051	91715-0003	NONE	d		OPEN	OPEN	NONE	BLACK

NOTES

- + DENOTES TERMINAL VOIDED POSITION  
 ● DENOTES TERMINAL LOADED POSITION  
 ↓ DENOTES POLARIZING RIB POSITION
- HOUSING NUMBER FOR MOLEX REFERENCE ONLY

<b>SEE SHEET 1</b> EC NO: IFC2016-0963 DRWNT: MURPHY 2016/01/05 CHKD: APPR: SHAMAHAN 2016/01/20	QUALITY SYMBOLS	GENERAL TOLERANCES (UNLESS SPECIFIED)	DIMENSION STYLE	SCALE	DESIGN UNITS	THIRD ANGLE PROJECTION																		
	= 0 = 0	<table border="1"> <tr> <th></th> <th>mm</th> <th>INCH</th> </tr> <tr> <td>4 PLACES</td> <td>± 0.10</td> <td>± 0.004</td> </tr> <tr> <td>3 PLACES</td> <td>± 0.05</td> <td>± 0.002</td> </tr> <tr> <td>2 PLACES</td> <td>± 0.10</td> <td>± 0.004</td> </tr> <tr> <td>1 PLACE</td> <td>± 0.2</td> <td>± 0.008</td> </tr> <tr> <td>0 PLACE</td> <td>±</td> <td>±</td> </tr> </table>		mm	INCH	4 PLACES	± 0.10	± 0.004	3 PLACES	± 0.05	± 0.002	2 PLACES	± 0.10	± 0.004	1 PLACE	± 0.2	± 0.008	0 PLACE	±	±	<b>MM ONLY</b> DRAWN BY: NMCNAMAR DATE: 2004/02/12 CHECKED BY: JDENNEHY DATE: 2004/02/13 APPROVED BY: BMAGUIRE DATE: 2004/02/16	1:1	METRIC	
		mm	INCH																					
	4 PLACES	± 0.10	± 0.004																					
3 PLACES	± 0.05	± 0.002																						
2 PLACES	± 0.10	± 0.004																						
1 PLACE	± 0.2	± 0.008																						
0 PLACE	±	±																						
DESCRIPTION	APPLI-MATE 2.5 FEMALE (MATL: NYLON PA6)		<b>molex</b>		DOCUMENT NO.	SHEET NO.																		
<b>BG</b>	DRAFT WHERE APPLICABLE MUST REMAIN WITHIN DIMENSIONS		<b>SEE CHARTS</b>		SD-91716-001	2 OF 10																		
THIS DRAWING CONTAINS INFORMATION THAT IS PROPRIETARY TO MOLEX INCORPORATED AND SHOULD NOT BE USED WITHOUT WRITTEN PERMISSION																								

### 4 CIRCUIT

MOLEX PART NO.	MOLEX HOUSING NO.	TERMINAL VOID POSITION	REMOVED POSITION KEYS	CONFIGURATION (SEE NOTES)	END WALLS		POLARIZING RIB	COLOUR STRIPE
					FIRST	LAST		
91716-0501	91715-0004	NONE	NONE		OPEN	OPEN	NONE	NONE
91716-0502	91715-0004	NONE	d		OPEN	OPEN	NONE	NONE
91716-0503	91715-0004	NONE	a d		OPEN	OPEN	NONE	NONE
91716-0504	91715-0004	NONE	c e		OPEN	OPEN	NONE	NONE
91716-0505	91715-0004	NONE	a		OPEN	OPEN	NONE	NONE
91716-0506	91715-0204	NONE	NONE		OPEN	OPEN	<b>BETWEEN CKT 2&amp;3</b>	NONE
91716-0538	91715-0004	NONE	b		OPEN	OPEN	NONE	NONE
91716-0530	91715-0004	NONE	b c		OPEN	OPEN	NONE	NONE
91716-0539	91715-0004	NONE	a b		OPEN	OPEN	NONE	NONE
91716-0540	91715-0004	NONE	d e		OPEN	OPEN	NONE	NONE
91716-0541	91715-0004	NONE	ALL		OPEN	OPEN	NONE	NONE
91716-0542	91715-0004	NONE	a b e		OPEN	OPEN	NONE	NONE
91716-0507	91715-0004	<b>CKT 1</b>	NONE		OPEN	OPEN	NONE	NONE
91716-0543	91715-0304	NONE	NONE		OPEN	OPEN	<b>BETWEEN CKT 3&amp;4</b>	<b>RED</b>
91716-0544	91715-0204	NONE	NONE		OPEN	OPEN	<b>BETWEEN CKT 2&amp;3</b>	<b>BLUE</b>
91716-0545	91715-0004	NONE	d		OPEN	OPEN	NONE	<b>BLUE</b>
91716-0546	91715-0004	NONE	b		OPEN	OPEN	NONE	<b>RED</b>
91716-0547	91715-0004	NONE	b c		OPEN	OPEN	NONE	<b>GREEN</b>
91716-0548	91715-0004	NONE	c d		OPEN	OPEN	NONE	<b>RED</b>
91716-0549	91715-0004	NONE	a c e		OPEN	OPEN	NONE	NONE

- NOTES
- + DENOTES TERMINAL VOIDED POSITION  
 ⊕ DENOTES TERMINAL LOADED POSITION  
 | DENOTES POLARIZING RIB POSITION
  - HOUSING NUMBER FOR MOLEX REFERENCE ONLY

### 4 CIRCUIT (cont'd)

MOLEX PART NO.	MOLEX HOUSING NO.	TERMINAL VOID POSITION	REMOVED POSITION KEYS	CONFIGURATION (SEE NOTES)	END WALLS		POLARIZING RIB	COLOUR STRIPE
					FIRST	LAST		
91716-0550	91715-0104	NONE	NONE		OPEN	OPEN	<b>BETWEEN CKT 1&amp;2</b>	NONE
91716-0551	91715-0004	NONE	NONE		OPEN	OPEN	NONE	<b>GREEN</b>
91716-0552	91715-0004	NONE	b c d		OPEN	OPEN	NONE	NONE
91716-0553	91715-0004	NONE	b d		OPEN	OPEN	NONE	NONE
91716-0554	91715-0004	NONE	a b d		OPEN	OPEN	NONE	NONE
91716-0555	91715-0004	NONE	a c e		OPEN	OPEN	NONE	<b>BLACK</b>
91716-0556	91715-0004	NONE	a e		OPEN	OPEN	NONE	NONE
91716-0557	91715-0104	NONE	a b d e		OPEN	OPEN	<b>BETWEEN CKT 1&amp;2</b>	NONE
91716-0558	91715-0004	NONE	a c		OPEN	OPEN	NONE	NONE
91716-0559	91715-0004	NONE	b e		OPEN	OPEN	NONE	NONE

<b>SEE SHEET 1</b> EC NO: IPG2016-0963 DRAWN BY: MURPHY 2016/01/05 CHKD: APPR: SHAMHAN 2016/01/20 BG	QUALITY SYMBOLS ▽=0 ▽=0	GENERAL TOLERANCES (UNLESS SPECIFIED) mm INCH 4 PLACES ±.--- ±.--- 3 PLACES ±0.05 ±.--- 2 PLACES ±0.10 ±.--- 1 PLACE ±0.2 ±.--- 0 PLACE ± ±.	DIMENSION STYLE <b>MM ONLY</b>	SCALE 5:1	DESIGN UNITS METRIC	THIRD ANGLE PROJECTION	
	DRAWN BY DATE NMCNAR 2004/02/12	CHECKED BY DATE JDENNEY 2004/02/13	APPROVED BY DATE BMAGUIRE 2004/02/16	MATERIAL NO. SEE CHARTS	DOCUMENT NO. SD-91716-001	SHEET NO. 3 OF 10	TITLE <b>APPLI-MATE 2.5 FEMALE (MATL: NYLON PA6)</b>
	DRAFT WHERE APPLICABLE MUST REMAIN WITHIN DIMENSIONS						THIS DRAWING CONTAINS INFORMATION THAT IS PROPRIETARY TO MOLEX INCORPORATED AND SHOULD NOT BE USED WITHOUT WRITTEN PERMISSION

5 CIRCUIT								
MOLEX PART NO.	MOLEX HOUSING NO.	TERMINAL VOID POSITION	REMOVED POSITION KEYS	CONFIGURATION (SEE NOTES)	END WALLS		POLARIZING RIB	COLOUR STRIPE
					FIRST	LAST		
91716-1001	91715-0005	NONE	NONE		OPEN	OPEN	NONE	NONE
91716-1002	91715-0305	NONE	ALL		OPEN	OPEN	<b>BETWEEN CKT 3&amp;4</b>	NONE
91716-1003	91715-0405	NONE	NONE		OPEN	OPEN	<b>BETWEEN CKT 4&amp;5</b>	NONE
91716-1004	91715-0005	NONE	c d		OPEN	OPEN	NONE	NONE
91716-1005	91715-0005	NONE	a		OPEN	OPEN	NONE	NONE
91716-1006	91715-0005	NONE	b		OPEN	OPEN	NONE	NONE
91716-1007	91715-0005	NONE	a b e f		OPEN	OPEN	NONE	NONE
91716-1008	91715-0205	NONE	NONE		OPEN	OPEN	<b>BETWEEN CKT 2&amp;3</b>	NONE
91716-1009	91715-0005	<b>CKT 2, 3, 4</b>	NONE		OPEN	OPEN	NONE	NONE
91716-1010	91715-0005	<b>CKT 2</b>	c		OPEN	OPEN	NONE	NONE
91716-1011	91715-0005	<b>CKT 2</b>	d		OPEN	OPEN	NONE	NONE
91716-1012	91715-0005	<b>CKT 2</b>	b		OPEN	OPEN	NONE	NONE
91716-1013	91715-0005	<b>CKT 2</b>	a		OPEN	OPEN	NONE	NONE
91716-1014	91715-0005	NONE	b c d e		OPEN	OPEN	NONE	NONE
91716-1015	91715-0305	<b>CKT 2,3,4</b>	NONE		OPEN	OPEN	<b>BETWEEN CKT 3&amp;4</b>	<b>RED</b>
91716-1016	91715-0005	<b>CKT 2</b>	b		OPEN	OPEN	NONE	<b>RED</b>
91716-1017	91715-0005	NONE	d e		OPEN	OPEN	NONE	NONE
91716-1018	91715-0005	NONE	a d f		OPEN	OPEN	NONE	NONE
91716-1019	91715-0105	NONE	NONE		OPEN	OPEN	<b>BETWEEN CKT 1&amp;2</b>	NONE
91716-1020	91715-0005	<b>CKT 2, 3, 4</b>	b		OPEN	OPEN	NONE	NONE
91716-1021	91715-0005	NONE	d		OPEN	OPEN	NONE	NONE
91716-1022	91715-0005	NONE	b f		OPEN	OPEN	NONE	<b>RED</b>
91716-1023	91715-0005	<b>CKT 2, 3, 4</b>	c e		OPEN	OPEN	NONE	NONE
91716-1024	91715-0205	NONE	a b e f		OPEN	OPEN	<b>BETWEEN CKT 2&amp;3</b>	NONE
91716-1025	91715-0005	<b>CKT 2, 3, 4</b>	c f		OPEN	OPEN	NONE	NONE

5 CIRCUIT								
MOLEX PART NO.	MOLEX HOUSING NO.	TERMINAL VOID POSITION	REMOVED POSITION KEYS	CONFIGURATION (SEE NOTES)	END WALLS		POLARIZING RIB	COLOUR STRIPE
					FIRST	LAST		
91716-1026	<b>93473-0205</b>	NONE	ALL		OPEN	OPEN	<b>BETWEEN CKT 2&amp;3</b>	LOCKING RETENTION FEATURE
91716-1027	91715-0205	NONE	ALL		OPEN	OPEN	<b>BETWEEN CKT 2&amp;3</b>	NONE
91716-1028	<b>93473-0005</b>	NONE	NONE		OPEN	OPEN	NONE	LOCKING RETENTION FEATURE

NOTES  
 1. + DENOTES TERMINAL VOIDED POSITION  
 ● DENOTES TERMINAL LOADED POSITION  
 | DENOTES POLARIZING RIB POSITION  
 2. HOUSING NUMBER FOR MOLEX REFERENCE ONLY

SEE SHEET 1 EC NO: IPG2016-0963 DRWNT: MURPHY CHYD: APPR: SHAMHAN 2016/01/20 BG	QUALITY SYMBOLS 	GENERAL TOLERANCES (UNLESS SPECIFIED) 4 PLACES ± 0.15 ± 0.05 3 PLACES ± 0.05 ± 0.02 2 PLACES ± 0.10 ± 0.05 1 PLACE ± 0.2 ± 0.1 0 PLACE ± ±	DIMENSION STYLE <b>MM ONLY</b>	SCALE <b>5:1</b>	DESIGN UNITS <b>METRIC</b>	THIRD ANGLE PROJECTION 	DRAWN BY NMCNAR	DATE 2004/02/12	TITLE <b>APPLI-MATE 2.5 FEMALE (MATL: NYLON PA6)</b>	
	DRAFT WHERE APPLICABLE MUST REMAIN WITHIN DIMENSIONS	APPROVED BY BMAGUIRE	DATE 2004/02/16	MATERIAL NO. <b>SEE CHARTS</b>	DOCUMENT NO. <b>SD-91716-001</b>	SHEET NO. 4 OF 10	THIS DRAWING CONTAINS INFORMATION THAT IS PROPRIETARY TO MOLEX INCORPORATED AND SHOULD NOT BE USED WITHOUT WRITTEN PERMISSION			
	AN ANGULAR ±1/2°									
	SIZE 1									

6 CIRCUIT								
MOLEX PART NO.	MOLEX HOUSING NO.	TERMINAL VOID POSITION	REMOVED POSITION KEYS	CONFIGURATION (SEE NOTES)	END WALLS		POLARIZING RIB	COLOUR STRIPE
					FIRST	LAST		
91716-1501	91715-0006	NONE	NONE		OPEN	OPEN	NONE	NONE
91716-1502	91715-0306	NONE	ALL		OPEN	OPEN	<b>BETWEEN CKT 3&amp;4</b>	NONE
91716-1503	91715-0006	NONE	c e f g		OPEN	OPEN	NONE	NONE
91716-1504	91715-0206	NONE	ALL		OPEN	OPEN	<b>BETWEEN CKT 2&amp;3</b>	NONE
91716-1505	91715-0006	<b>CKT 2, 5</b>	d f		OPEN	OPEN	NONE	NONE
91716-1506	91715-0006	NONE	a b f g		OPEN	OPEN	NONE	NONE
91716-1507	91715-0006	NONE	e f		OPEN	OPEN	NONE	NONE
91716-1509	91715-0006	NONE	g		OPEN	OPEN	NONE	NONE
91716-1510	91715-0006	<b>CKT 2</b>	c f		OPEN	OPEN	NONE	NONE
91716-1511	91715-0006	<b>CKT 2, 5</b>	NONE		OPEN	OPEN	NONE	NONE
91716-1512	91715-0006	<b>CKT 3, 5</b>	NONE		OPEN	OPEN	NONE	NONE
91716-1513	91715-0006	<b>CKT 2, 4</b>	b d e f		OPEN	OPEN	NONE	NONE
91716-1514	91715-0106	<b>CKT 3, 5</b>	NONE		OPEN	OPEN	<b>BETWEEN CKT 1&amp;2</b>	NONE
91716-1515	91715-0206	<b>CKT 2, 5</b>	NONE		OPEN	OPEN	<b>BETWEEN CKT 2&amp;3</b>	NONE
91716-1516	91715-0306	NONE	c f		OPEN	OPEN	<b>BETWEEN CKT 3&amp;4</b>	NONE
91716-1517	91715-0006	NONE	c e		OPEN	OPEN	NONE	NONE
91716-1518	91715-0006	<b>CKT 2, 4</b>	NONE		OPEN	OPEN	NONE	NONE
91716-1519	91715-0006	NONE	a c e		OPEN	OPEN	NONE	NONE
91716-1520	91715-0006	<b>CKT 5</b>	c e		OPEN	OPEN	NONE	NONE
91716-1521	91715-0006	<b>CKT 2, 4, 5, 6</b>	c e		OPEN	OPEN	NONE	NONE
91716-1522	91715-0006	<b>CKT 2, 6</b>	c e		OPEN	OPEN	NONE	NONE

6 CIRCUIT (cont'd)								
MOLEX PART NO.	MOLEX HOUSING NO.	TERMINAL VOID POSITION	REMOVED POSITION KEYS	CONFIGURATION (SEE NOTES)	END WALLS		POLARIZING RIB	COLOUR STRIPE
					FIRST	LAST		
91716-1523	91715-0406	NONE	NONE		OPEN	OPEN	<b>BETWEEN CKT 4&amp;5</b>	NONE
91716-1524	91715-0006	<b>CKT 2, 4, 5, 6</b>	NONE		OPEN	OPEN	NONE	NONE
91716-1525	91715-0006	<b>CKT 2, 6</b>	NONE		OPEN	OPEN	NONE	NONE
91716-1526	91715-0006	<b>CKT 2, 5</b>	NONE		OPEN	OPEN	NONE	NONE
91716-1527	91715-0006	<b>CKT 2, 5</b>	c e		OPEN	OPEN	NONE	NONE
91716-1528	91715-0006	<b>CKT 2, 5</b>	a b d f g		OPEN	OPEN	NONE	<b>GREEN</b>
91716-1529	91715-0006	NONE	d		OPEN	OPEN	NONE	NONE
91716-1531	91715-0006	<b>CKT 1, 2, 3, 5</b>	NONE		OPEN	OPEN	NONE	NONE
91716-1532	91715-0006	<b>CKT 1, 2, 3, 5</b>	d f		OPEN	OPEN	NONE	NONE
91716-1534	91715-0006	<b>CKT 3, 4</b>	b d f		OPEN	OPEN	NONE	NONE
91716-1535	91715-0006	<b>CKT 4, 5</b>	b d f		OPEN	OPEN	NONE	NONE
91716-1536	91715-0206	NONE	NONE		OPEN	OPEN	<b>BETWEEN CKT 2&amp;3</b>	NONE
91716-1537	91715-0006	NONE	d		OPEN	OPEN	NONE	<b>BLUE</b>
91716-1538	91715-0006	<b>CKT 2, 5</b>	b d		OPEN	OPEN	NONE	NONE
91716-1539	91715-0006	<b>CKT 5, 6</b>	c f		OPEN	OPEN	NONE	NONE
91716-1540	91715-0006	<b>CKT 2, 4</b>	d e		OPEN	OPEN	NONE	<b>GREEN</b>
91716-1541	91715-0006	NONE	a f g		OPEN	OPEN	NONE	NONE
91716-1542	91715-0006	NONE	NONE		OPEN	OPEN	NONE	<b>RED</b>
91716-1543	91715-0506	NONE	NONE		OPEN	OPEN	<b>BETWEEN 5&amp;6</b>	NONE
91716-1544	91715-0006	NONE	c e g		OPEN	OPEN	NONE	<b>RED</b>
91716-1545	91715-0006	NONE	d f		OPEN	OPEN	NONE	<b>BLACK</b>

- NOTES
- + DENOTES TERMINAL VOIDED POSITION  
 ○ DENOTES TERMINAL LOADED POSITION  
 | DENOTES POLARIZING RIB POSITION
  - HOUSING NUMBER FOR MOLEX REFERENCE ONLY

SEE SHEET 1 ELEC NO: IPC2016-0963 DRAWN BY: MURPHY 2016/01/05 CHKD: APPROVED: 2016/01/20 APPR: SHAMAM	QUALITY SYMBOLS ▽=0 ▽=0	GENERAL TOLERANCES (UNLESS SPECIFIED) mm INCH 4 PLACES ±.--- ±.--- 3 PLACES ±0.05 ±.--- 2 PLACES ±0.10 ±.--- 1 PLACE ±0.2 ±.--- 0 PLACE ± ±.---	DIMENSION STYLE MM ONLY	SCALE 1:1	DESIGN UNITS METRIC	THIRD ANGLE PROJECTION
	DRAWN BY: NMCNAMAR 2004/02/12 CHECKED BY: JDENNEHY 2004/02/13 APPROVED BY: BMAGUIRE 2004/02/16	TITLE APPLI-MATE 2.5 FEMALE (MATL: NYLON PA6)	MATERIAL NO. SEE CHARTS	DOCUMENT NO. SD-91716-001	SHEET NO. 5 OF 10	
	DRAFT WHERE APPLICABLE MUST REMAIN WITHIN DIMENSIONS					
	THIS DRAWING CONTAINS INFORMATION THAT IS PROPRIETARY TO MOLEX INCORPORATED AND SHOULD NOT BE USED WITHOUT WRITTEN PERMISSION					

### 6 CIRCUIT (cont'd)

MOLEX PART NO.	MOLEX HOUSING NO.	TERMINAL VOID POSITION	REMOVED POSITION KEYS	CONFIGURATION (SEE NOTES)	END WALLS		POLARIZING RIB	COLOUR STRIPE
					FIRST	LAST		
91716-1546	91715-0006	NONE	a d		OPEN	OPEN	NONE	NONE
91716-1547	91715-0006	NONE	b e f		OPEN	OPEN	NONE	NONE
91716-1548	91715-0006	NONE	c d e		OPEN	OPEN	NONE	NONE
91716-1549	91715-0406	NONE	NONE		OPEN	OPEN	<b>BETWEEN</b> <b>CKT 4&amp;5</b>	NONE
91716-1550	91715-0006	NONE	b d f		OPEN	OPEN	NONE	NONE
91716-1551	91715-0006	NONE	a c e g		OPEN	OPEN	NONE	NONE
91716-1552	91715-0006	NONE	a b d f		OPEN	OPEN	NONE	NONE
91716-1553	91715-0006	<b>CCT 2, 5</b>	c d		OPEN	OPEN	NONE	<b>BLACK</b>
91716-1554	91715-0006	<b>CCT 2, 4</b>	b		OPEN	OPEN	NONE	<b>RED</b>
91716-1555	91715-0006	NONE	c f		OPEN	OPEN	NONE	NONE
91716-1556	91715-0006	NONE	b d e g		OPEN	OPEN	NONE	NONE
91716-1557	91715-0006	<b>CCT 2&amp;4</b>	b g		OPEN	OPEN	NONE	<b>RED</b>
91716-1558	91715-0006	NONE	d f		OPEN	OPEN	NONE	NONE
91716-1559	91715-0006	<b>CCT 1</b>	NONE		OPEN	OPEN	NONE	NONE
91716-1560	91715-0006	NONE	a c e f g		OPEN	OPEN	NONE	NONE
91716-1561	91715-0006	NONE	a d g		OPEN	OPEN	NONE	NONE
91716-1562	91715-0006	NONE	a c d e f g		OPEN	OPEN	NONE	NONE
91716-1563	91715-0006	<b>CCT 5</b>	a c d e f g		OPEN	OPEN	NONE	NONE
91716-1564	91715-0006	<b>CCT 6</b>	a c d e f g		OPEN	OPEN	NONE	NONE

### 6 CIRCUIT (cont'd)

MOLEX PART NO.	MOLEX HOUSING NO.	TERMINAL VOID POSITION	REMOVED POSITION KEYS	CONFIGURATION (SEE NOTES)	END WALLS		POLARIZING RIB	COLOUR STRIPE	
					FIRST	LAST			
91716-1565	91715-0006	<b>CCT 5</b>	NONE		OPEN	OPEN	NONE	NONE	
91716-1566	<b>93473-0006</b>	NONE	NONE		OPEN	OPEN	NONE	NONE	LOCKING RETENTION FEATURE
91716-1567	<b>93473-0006</b>	NONE	d f		OPEN	OPEN	NONE	NONE	LOCKING RETENTION FEATURE
91716-1568	<b>93473-0006</b>	<b>CCT 1</b>	NONE		OPEN	OPEN	NONE	NONE	LOCKING RETENTION FEATURE
91716-1569	<b>93473-0006</b>	NONE	a c d e f g		OPEN	OPEN	NONE	NONE	LOCKING RETENTION FEATURE
91716-1570	<b>93473-0006</b>	<b>CCT 5</b>	a c d e f g		OPEN	OPEN	NONE	NONE	LOCKING RETENTION FEATURE
91716-1571	<b>93473-0006</b>	<b>CCT 5</b>	NONE		OPEN	OPEN	NONE	NONE	LOCKING RETENTION FEATURE
91716-1572	<b>93473-0006</b>	NONE	d		OPEN	OPEN	NONE	<b>PURPLE</b>	LOCKING RETENTION FEATURE
91716-1573	91715-0006	<b>CCT 2, 5</b>	c e g		OPEN	OPEN	NONE	<b>RED</b>	

- NOTES
- + DENOTES TERMINAL VOIDED POSITION  
● DENOTES TERMINAL LOADED POSITION  
| DENOTES POLARIZING RIB POSITION
  - HOUSING NUMBER FOR MOLEX REFERENCE ONLY

SEE SHEET 1 DEC NO: P02076-0963 DRAWN BY: MURPHY CHKD: SHAMHAN APPR: SHAMHAN 2016/01/20	QUALITY SYMBOLS	GENERAL TOLERANCES (UNLESS SPECIFIED)	DIMENSION STYLE	SCALE	DESIGN UNITS	THIRD ANGLE PROJECTION
	▽=0	mm INCH	MM ONLY	1:1	METRIC	
	▽=0	4 PLACES ± --- ± ---	DRAWN BY DATE	TITLE		
		3 PLACES ± 0.05 ± ---	NMCNAMAR 2004/02/12	APPLI-MATE 2.5 FEMALE (MATL: NYLON PA6)		
	2 PLACES ± 0.10 ± ---	CHECKED BY DATE	DOCUMENT NO.			
	1 PLACE ± 0.2 ± ---	JDENNEHY 2004/02/13	SD-91716-001			
	0 PLACE ± ±	APPROVED BY DATE	SHEET NO.			
	ANGULAR ±1/2°	BMAGUIRE 2004/02/16	6 OF 10			
	DRAFT WHERE APPLICABLE MUST REMAIN WITHIN DIMENSIONS	MATERIAL NO.	THIS DRAWING CONTAINS INFORMATION THAT IS PROPRIETARY TO MOLEX INCORPORATED AND SHOULD NOT BE USED WITHOUT WRITTEN PERMISSION			
		SEE CHARTS				

7 CIRCUIT								
MOLEX PART NO.	MOLEX HOUSING NO.	TERMINAL VOID POSITION	REMOVED POSITION KEYS	CONFIGURATION (SEE NOTES)	END WALLS		POLARIZING RIB	COLOUR STRIPE
					FIRST	LAST		
91716-2001	91715-0007	NONE	NONE	nnnnnnnn + 1234567	OPEN	OPEN	NONE	NONE
91716-2002	91715-0207	NONE	ALL	abcdefgh + 1234567	OPEN	OPEN	<b>BETWEEN CKT 2&amp;3</b>	NONE
91716-2004	91715-0007	NONE	a	nnnnnnnn + 1234567	OPEN	OPEN	NONE	NONE
91716-2005	91715-0007	<b>CKT 2</b>	h	nnnnnnnh + 1234567	OPEN	OPEN	NONE	NONE
91716-2006	91715-0007	<b>CKT 4</b>	a	nnnnnnnn + 1234567	OPEN	OPEN	NONE	NONE
91716-2007	91715-0007	<b>CKT 2</b>	NONE	nnnnnnnn + 1234567	OPEN	OPEN	NONE	NONE
91716-2008	91715-0007	<b>CKT 6</b>	NONE	nnnnnnnn + 1234567	OPEN	OPEN	NONE	NONE
91716-2009	91715-0007	<b>CKT 2</b>	b c e g	nnccnngn + 1234567	OPEN	OPEN	NONE	<b>BLUE</b>
91716-2010	91715-0007	<b>CKT 4, 6</b>	b d f	nnbdfn + 1234567	OPEN	OPEN	NONE	<b>RED</b>
91716-2011	91715-0007	<b>CKT 4, 6</b>	b d f	nnbdfn + 1234567	OPEN	OPEN	NONE	<b>BLUE</b>
91716-2012	91715-0007	<b>CKT 2</b>	NONE	nnnnnnnn + 1234567	OPEN	OPEN	NONE	<b>BLUE</b>
91716-2013	91715-0007	<b>CKT 2</b>	b d e f h	nnbdefnh + 1234567	OPEN	OPEN	NONE	<b>BLUE</b>
91716-2014	91715-0007	<b>CKT 4, 6</b>	NONE	nnnnnnnn + 1234567	OPEN	OPEN	NONE	<b>BLUE</b>
91716-2015	91715-0007	<b>CKT 4, 6</b>	c d e f h	nncdfnh + 1234567	OPEN	OPEN	NONE	<b>BLUE</b>
91716-2016	91715-0007	<b>CKT 6</b>	c d e f h	nncdfnh + 1234567	OPEN	OPEN	NONE	<b>BLUE</b>
91716-2017	91715-0007	<b>CKT 6</b>	c d e f	nncdfn + 1234567	OPEN	OPEN	NONE	<b>BLUE</b>
91716-2018	91715-0007	<b>CKT 6</b>	NONE	nnnnnnnn + 1234567	OPEN	OPEN	NONE	<b>BLUE</b>
91716-2019	91715-0007	<b>CKT 2</b>	NONE	nnnnnnnn + 1234567	OPEN	OPEN	NONE	<b>BLACK</b>
91716-2020	91715-0007	NONE	a c e f h	anncefnh + 1234567	OPEN	OPEN	NONE	NONE
91716-2021	91715-0007	NONE	a	nnnnnnnn + 1234567	OPEN	OPEN	NONE	<b>BLACK</b>
91716-2022	91715-0007	NONE	b c d f	nnbcdn + 1234567	OPEN	OPEN	NONE	NONE
91716-2023	91715-0007	NONE	a d	nnnndn + 1234567	OPEN	OPEN	NONE	NONE
91716-2024	91715-0007	NONE	a b e f	abnnfn + 1234567	OPEN	OPEN	NONE	NONE
91716-2025	91715-0507	NONE	NONE	nnnnnnnn + 1234567	OPEN	OPEN	<b>BETWEEN CKT 5&amp;6</b>	NONE
91716-2026	91715-0007	NONE	ALL	abcdefgh + 1234567	OPEN	OPEN	NONE	NONE
91716-2027	91715-0007	<b>CKT 6</b>	a c d e f	anncdfn + 1234567	OPEN	OPEN	NONE	<b>BLUE</b>

7 CIRCUIT (cont'd)								
MOLEX PART NO.	MOLEX HOUSING NO.	TERMINAL VOID POSITION	REMOVED POSITION KEYS	CONFIGURATION (SEE NOTES)	END WALLS		POLARIZING RIB	COLOUR STRIPE
					FIRST	LAST		
91716-2028	91715-0007	<b>CCT 1,2,3,4,6</b>	a c f	anccfn + 1234567	OPEN	OPEN	NONE	NONE
91716-2029	91715-0007	<b>CCT 4</b>	a	nnnnnnnn + 1234567	OPEN	OPEN	NONE	<b>RED</b>
91716-2030	<b>93473-0307</b>	NONE	ALL	abcdefgh + 1234567	OPEN	OPEN	<b>BETWEEN CKT 3&amp;4</b>	NONE
91716-2031	91715-0307	NONE	ALL	abcdefgh + 1234567	OPEN	OPEN	<b>BETWEEN CKT 3&amp;4</b>	NONE
91716-2032	<b>93473-0007</b>	NONE	NONE	nnnnnnnn + 1234567	OPEN	OPEN	NONE	NONE
91716-2033	91715-0627	NONE	NONE	nnnnnnnn + 1234567	CLOSED	CLOSED	<b>BETWEEN CKT 6&amp;7</b>	NONE

LOCKING RETENTION FEATURE

LOCKING RETENTION FEATURE

NOTES

- + DENOTES TERMINAL VOIDED POSITION  
 ● DENOTES TERMINAL LOADED POSITION  
 ▽ DENOTES POLARIZING RIB POSITION
- HOUSING NUMBER FOR MOLEX REFERENCE ONLY

<b>SEE SHEET 1</b> EC NO: IPG2016-0963 DRAWN: J MURPHY 2016/01/05 CHKD: APPR: SHAMAHAN 2016/01/20 BG	QUALITY SYMBOLS ▽=0 ▽=0	GENERAL TOLERANCES (UNLESS SPECIFIED) mm INCH 4 PLACES ± --- ± --- 3 PLACES ± 0.05 ± --- 2 PLACES ± 0.10 ± --- 1 PLACE ± 0.2 ± --- 0 PLACE ± ±	DIMENSION STYLE MM ONLY	SCALE 1:1	DESIGN UNITS METRIC	THIRD ANGLE PROJECTION	
	DRAWN BY NMCNAMAR	DATE 2004/02/12	CHECKED BY J DENNEHY	DATE 2004/02/13	TITLE APPLI-MATE 2.5 FEMALE (MATL: NYLON PA6)		
	APPROVED BY BMAGUIRE	DATE 2004/02/16	MATERIAL NO. SEE CHARTS			DOCUMENT NO. SD-91716-001	SHEET NO. 7 OF 10
	DRAFT WHERE APPLICABLE MUST REMAIN WITHIN DIMENSIONS						THIS DRAWING CONTAINS INFORMATION THAT IS PROPRIETARY TO MOLEX INCORPORATED AND SHOULD NOT BE USED WITHOUT WRITTEN PERMISSION

# 8 CIRCUIT

MOLEX PART NO.	MOLEX HOUSING NO.	TERMINAL VOID POSITION	REMOVED POSITION KEYS	CONFIGURATION (SEE NOTES)	END WALLS		POLARIZING RIB	COLOUR STRIPE
					FIRST	LAST		
91716-2501	91715-0008	NONE	NONE		OPEN	OPEN	NONE	NONE
91716-2502	91715-0308	NONE	NONE		OPEN	OPEN	<b>BETWEEN CKT 3&amp;4</b>	NONE
91716-2503	91715-0008	NONE	c f h i		OPEN	OPEN	NONE	NONE
91716-2504	91715-0008	NONE	b c d h i		OPEN	OPEN	NONE	NONE
91716-2505	91715-0008	NONE	b c g h		OPEN	OPEN	NONE	<b>BLUE</b>
91716-2506	91715-0008	NONE	c f		OPEN	OPEN	NONE	NONE
91716-2507	91715-0008	NONE	c f h i		OPEN	OPEN	NONE	<b>BLUE</b>
91716-2508	91715-0008	NONE	NONE		OPEN	OPEN	NONE	<b>BLUE</b>
91716-2509	91715-0008	NONE	a c d e g i		OPEN	OPEN	NONE	<b>BLUE</b>
91716-2510	91715-0008	NONE	c d e f		OPEN	OPEN	NONE	<b>BLUE</b>
91716-2511	91715-0008	NONE	NONE		OPEN	OPEN	NONE	<b>BLACK</b>
91716-2512	91715-0008	NONE	c f h i		OPEN	OPEN	NONE	<b>BLACK</b>
91716-2513	91715-0008	NONE	c d g h		OPEN	OPEN	NONE	NONE
91716-2514	91715-0008	NONE	a c d e f g h i		OPEN	OPEN	NONE	<b>BLUE</b>
91716-2515	91715-0008	NONE	a b d f h i		OPEN	OPEN	NONE	NONE
91716-2516	91715-0008	NONE	b c d h i		OPEN	OPEN	NONE	<b>BLUE</b>
91716-2517	91715-2008	NONE	NONE		OPEN	OPEN	<b>BETWEEN CKT 1&amp;2 + CKT 7&amp;8</b>	NONE
91716-2518	91715-0008	NONE	b c d f h i		OPEN	OPEN	NONE	NONE
91716-2519	91715-0008	NONE	a c e f h i		OPEN	OPEN	NONE	NONE
91716-2520	91715-0008	NONE	ALL		OPEN	OPEN	NONE	NONE
91716-2521	91715-0008	<b>CKT 7, 8</b>	a b d f h i		OPEN	OPEN	NONE	NONE
91716-2522	91715-0008	NONE	b c d f h i		OPEN	OPEN	NONE	<b>BLUE</b>

**NOTES**

- + DENOTES TERMINAL VOIDED POSITION  
 ● DENOTES TERMINAL LOADED POSITION  
 | DENOTES POLARIZING RIB POSITION
- HOUSING NUMBER FOR MOLEX REFERENCE ONLY

SEE SHEET 1 EC NO: IPG2076-0963 DRAWN: MURPHY 2016/01/05 CHKD: APPR: SHAMAHAN 2016/01/20 BG	QUALITY SYMBOLS	GENERAL TOLERANCES (UNLESS SPECIFIED)	DIMENSION STYLE	SCALE	DESIGN UNITS	THIRD ANGLE PROJECTION
	$\nabla=0$ $\nabla=0$	mm    INCH 4 PLACES ± --- ± --- 3 PLACES ± 0.05 ± --- 2 PLACES ± 0.10 ± --- 1 PLACE ± 0.2 ± --- 0 PLACE ±    ±	M M ONLY DRAWN BY DATE NMCNAR 2004/02/12 CHECKED BY DATE J DENNEHY 2004/02/13 APPROVED BY DATE BMAGUIRE 2004/02/16	1:1	METRIC	
	DRAFT WHERE APPLICABLE MUST REMAIN WITHIN DIMENSIONS	SEE CHARTS THIS DRAWING CONTAINS INFORMATION THAT IS PROPRIETARY TO MOLEX INCORPORATED AND SHOULD NOT BE USED WITHOUT WRITTEN PERMISSION	MATERIAL NO. SD-91716-001	DOCUMENT NO. SD-91716-001	SHEET NO. 8 OF 10	
	TITLE APPLI-MATE 2.5 FEMALE (MATL: NYLON PA6)					



### 8 CIRCUIT (cont'd)

MOLEX PART NO.	MOLEX HOUSING NO.	TERMINAL VOID POSITION	REMOVED POSITION KEYS	CONFIGURATION (SEE NOTES)	END WALLS		POLARIZING RIB	COLOUR STRIPE
					FIRST	LAST		
91716-2521	91715-0008	<b>CKT 7, 8</b>	a b d f h i		OPEN	OPEN	NONE	NONE
91716-2522	91715-0008	NONE	b c d f h i		OPEN	OPEN	NONE	<b>BLUE</b>

### 10 CIRCUIT

MOLEX PART NO.	MOLEX HOUSING NO.	TERMINAL VOID POSITION	REMOVED POSITION KEYS	CONFIGURATION (SEE NOTES)	END WALLS		POLARIZING RIB	COLOUR STRIPE
					FIRST	LAST		
91716-3501	91715-0010	NONE	NONE		OPEN	OPEN	NONE	NONE
91716-3502	91715-0210	NONE	ALL		OPEN	OPEN	<b>BETWEEN CKT 2&amp;3</b>	NONE
91716-3503	91715-0010	<b>CKT 2, 5, 7, 9</b>	NONE		OPEN	OPEN	NONE	NONE
91716-3504	91715-0410	NONE	NONE		OPEN	OPEN	<b>BETWEEN CKT 4&amp;5</b>	NONE

### 9 CIRCUIT

MOLEX PART NO.	MOLEX HOUSING NO.	TERMINAL VOID POSITION	REMOVED POSITION KEYS	CONFIGURATION (SEE NOTES)	END WALLS		POLARIZING RIB	COLOUR STRIPE
					FIRST	LAST		
91716-3001	91715-0009	NONE	NONE		OPEN	OPEN	NONE	NONE
91716-3002	91715-0409	NONE	NONE		OPEN	OPEN	<b>BETWEEN CKT 4&amp;5</b>	NONE
91716-3003	91715-0009	<b>CKT 2, 5, 8</b>	NONE		OPEN	OPEN	NONE	NONE
91716-3004	91715-0209	NONE	NONE		OPEN	OPEN	<b>BETWEEN CKT 2&amp;3</b>	NONE
91716-3005	91715-0009	<b>CKT 2, 5, 8</b>	b c e g i j		OPEN	OPEN	NONE	<b>GREEN</b>
91716-3006	91715-0009	<b>CKT 2, 5, 8</b>	NONE		OPEN	OPEN	NONE	<b>GREEN</b>
91716-3007	91715-0009	<b>CKT 2, 5, 8</b>	b c e f g i j		OPEN	OPEN	NONE	<b>GREEN</b>
91716-3008	91715-0009	<b>CKT 2, 5, 8</b>	b c e f g i		OPEN	OPEN	NONE	<b>GREEN</b>
91716-3009	91715-0009	<b>CKT 2, 5, 7</b>	c g		OPEN	OPEN	NONE	NONE
91716-3010	91715-0009	<b>CKT 2, 5, 8</b>	b c h i		OPEN	OPEN	NONE	NONE
91716-3011	91715-0709	NONE	NONE		OPEN	OPEN	<b>BETWEEN CKT 7&amp;8</b>	NONE
91716-3012	91715-0509	NONE	NONE		OPEN	OPEN	<b>BETWEEN CKT 5&amp;6</b>	NONE
91716-3013	91715-0029	NONE	NONE		<b>CLOSED</b>	<b>CLOSED</b>	NONE	NONE

### 11 CIRCUIT

MOLEX PART NO.	MOLEX HOUSING NO.	TERMINAL VOID POSITION	REMOVED POSITION KEYS	CONFIGURATION (SEE NOTES)	END WALLS		POLARIZING RIB	COLOUR STRIPE
					FIRST	LAST		
91716-4001	91715-0011	NONE	NONE		OPEN	OPEN	NONE	NONE
91716-4002	91715-0031	NONE	NONE		<b>CLOSED</b>	<b>CLOSED</b>	NONE	NONE
91716-4003	91715-0511	NONE	NONE		OPEN	OPEN	<b>BETWEEN CCKT 5&amp;6</b>	NONE
91716-4004	91715-1031	NONE	NONE		<b>CLOSED</b>	<b>CLOSED</b>	<b>BETWEEN CCKT 10&amp;11</b>	NONE
91716-4005	91715-1011	NONE	NONE		OPEN	OPEN	<b>BETWEEN CCKT 10&amp;11</b>	NONE

### 12 CIRCUIT

MOLEX PART NO.	MOLEX HOUSING NO.	TERMINAL VOID POSITION	REMOVED POSITION KEYS	CONFIGURATION (SEE NOTES)	END WALLS		POLARIZING RIB	COLOUR STRIPE
					FIRST	LAST		
91716-4501	91715-0012	NONE	NONE		OPEN	OPEN	NONE	NONE
91716-4502	91715-0012	<b>CKT 2, 5, 8, 11</b>	b c d e j k l		OPEN	OPEN	NONE	<b>GREEN</b>
91716-4503	91715-0012	<b>CKT 2, 5, 8, 11</b>	NONE		OPEN	OPEN	NONE	<b>GREEN</b>
91716-4504	91715-0012	<b>CKT 2, 5, 8, 11</b>	a c d e g h i k l m		OPEN	OPEN	NONE	<b>GREEN</b>
91716-4505	91715-0012	<b>CKT 2, 5, 8, 11</b>	c d e g h i k l m		OPEN	OPEN	NONE	<b>GREEN</b>

- NOTES
- + DENOTES TERMINAL VOIDED POSITION  
 ● DENOTES TERMINAL LOADED POSITION  
 | DENOTES POLARIZING RIB POSITION
  - HOUSING NUMBER FOR MOLEX REFERENCE ONLY

<b>SEE SHEET 1</b> EC NO: IP02016-0963 DRAWN BY: MURPHY CHKD: BG APPR: SHAMAHAN 2016/01/20	QUALITY SYMBOLS	$\nabla=0$ $\nabla=0$	GENERAL TOLERANCES (UNLESS SPECIFIED)	mm    INCH 4 PLACES ± --- ± --- 3 PLACES ± 0.05 ± --- 2 PLACES ± 0.10 ± --- 1 PLACE ± 0.2 ± --- 0 PLACE ±    ±	DIMENSION STYLE	MM ONLY	SCALE	5:1	DESIGN UNITS	METRIC	THIRD ANGLE PROJECTION	
				DRAFT WHERE APPLICABLE MUST REMAIN WITHIN DIMENSIONS	CHECKED BY	JDENNEHY	DATE	2004/02/13	TITLE			
				APPROVED BY	BMAGUIRE	DATE	2004/02/16	APPLI-MATE 2.5 FEMALE (MATL: NYLON PA6)				
				MATERIAL NO.	SEE CHARTS			DOCUMENT NO.	SD-91716-001			
						THIS DRAWING CONTAINS INFORMATION THAT IS PROPRIETARY TO MOLEX INCORPORATED AND SHOULD NOT BE USED WITHOUT WRITTEN PERMISSION			SHEET NO. 9 OF 10			

### 13 CIRCUIT

MOLEX PART NO.	MOLEX HOUSING NO.	TERMINAL VOID POSITION	REMOVED POSITION KEYS	CONFIGURATION (SEE NOTES)	END WALLS		POLARIZING RIB	COLOUR STRIPE
					FIRST	LAST		
91716-5001	91715-0013	NONE	NONE	①②③④⑤⑥⑦⑧⑨⑩⑪⑫⑬ 1 2 3 4 5 6 7 8 9 10 11 12 13	OPEN	OPEN	NONE	NONE
91716-5002	91715-0013	<b>CKT 4, 6, 8, 10, 12</b>	NONE	④⑥⑧⑩⑫④⑥⑧⑩⑫④⑥⑧⑩⑫ 1 2 3 4 5 6 7 8 9 10 11 12 13	OPEN	OPEN	NONE	NONE
91716-5003	91715-0013	NONE	c f h i k l	①②③④⑤⑥⑦⑧⑨⑩⑪⑫⑬ 1 2 3 4 5 6 7 8 9 10 11 12 13	OPEN	OPEN	NONE	NONE

### 17 CIRCUIT

MOLEX PART NO.	MOLEX HOUSING NO.	TERMINAL VOID POSITION	REMOVED POSITION KEYS	CONFIGURATION (SEE NOTES)	END WALLS		POLARIZING RIB	COLOUR STRIPE
					FIRST	LAST		
91716-7001	91715-0017	NONE	NONE	①②③④⑤⑥⑦⑧⑨⑩⑪⑫⑬⑭⑮⑯⑰ 1 2 3 4 5 6 7 8 9 10 11 12 13 14 15 16 17	OPEN	OPEN	NONE	NONE

### 14 CIRCUIT

MOLEX PART NO.	MOLEX HOUSING NO.	TERMINAL VOID POSITION	REMOVED POSITION KEYS	CONFIGURATION (SEE NOTES)	END WALLS		POLARIZING RIB	COLOUR STRIPE
					FIRST	LAST		
91716-5501	91715-0014	NONE	NONE	①②③④⑤⑥⑦⑧⑨⑩⑪⑫⑬⑭ 1 2 3 4 5 6 7 8 9 10 11 12 13 14	OPEN	OPEN	NONE	NONE

### 18 CIRCUIT

MOLEX PART NO.	MOLEX HOUSING NO.	TERMINAL VOID POSITION	REMOVED POSITION KEYS	CONFIGURATION (SEE NOTES)	END WALLS		POLARIZING RIB	COLOUR STRIPE
					FIRST	LAST		
91716-7501	91715-0018	NONE	NONE	①②③④⑤⑥⑦⑧⑨⑩⑪⑫⑬⑭⑮⑯⑰⑱ 1 2 3 4 5 6 7 8 9 10 11 12 13 14 15 16 17 18	OPEN	OPEN	NONE	NONE

### 15 CIRCUIT

MOLEX PART NO.	MOLEX HOUSING NO.	TERMINAL VOID POSITION	REMOVED POSITION KEYS	CONFIGURATION (SEE NOTES)	END WALLS		POLARIZING RIB	COLOUR STRIPE
					FIRST	LAST		
91716-6001	91715-0015	NONE	NONE	①②③④⑤⑥⑦⑧⑨⑩⑪⑫⑬⑭⑮ 1 2 3 4 5 6 7 8 9 10 11 12 13 14 15	OPEN	OPEN	NONE	NONE
91716-6002	91715-0015	<b>CKT 4, 6, 8, 10, 12, 14</b>	a p	④⑥⑧⑩⑫④⑥⑧⑩⑫④⑥⑧⑩⑫④⑥⑧⑩⑫⑬⑭⑮ 1 2 3 4 5 6 7 8 9 10 11 12 13 14 15	OPEN	OPEN	NONE	NONE
91716-6003	91715-0515	NONE	a p	①②③④⑤⑥⑦⑧⑨⑩⑪⑫⑬⑭⑮ 1 2 3 4 5 6 7 8 9 10 11 12 13 14 15	OPEN	OPEN	<b>BETWEEN 5 &amp; 6</b>	NONE

### 19 CIRCUIT

MOLEX PART NO.	MOLEX HOUSING NO.	TERMINAL VOID POSITION	REMOVED POSITION KEYS	CONFIGURATION (SEE NOTES)	END WALLS		POLARIZING RIB	COLOUR STRIPE
					FIRST	LAST		
91716-8001	91715-0019	NONE	NONE	①②③④⑤⑥⑦⑧⑨⑩⑪⑫⑬⑭⑮⑯⑰⑱ 1 2 3 4 5 6 7 8 9 10 11 12 13 14 15 16 17 18 19	OPEN	OPEN	NONE	NONE

### 16 CIRCUIT

MOLEX PART NO.	MOLEX HOUSING NO.	TERMINAL VOID POSITION	REMOVED POSITION KEYS	CONFIGURATION (SEE NOTES)	END WALLS		POLARIZING RIB	COLOUR STRIPE
					FIRST	LAST		
91716-6501	91715-0016	NONE	NONE	①②③④⑤⑥⑦⑧⑨⑩⑪⑫⑬⑭⑮⑯⑰ 1 2 3 4 5 6 7 8 9 10 11 12 13 14 15 16	OPEN	OPEN	NONE	NONE

### 20 CIRCUIT

MOLEX PART NO.	MOLEX HOUSING NO.	TERMINAL VOID POSITION	REMOVED POSITION KEYS	CONFIGURATION (SEE NOTES)	END WALLS		POLARIZING RIB	COLOUR STRIPE
					FIRST	LAST		
91716-8501	91715-0020	NONE	NONE	①②③④⑤⑥⑦⑧⑨⑩⑪⑫⑬⑭⑮⑯⑰⑱⑲ 1 2 3 4 5 6 7 8 9 10 11 12 13 14 15 16 17 18 19 20	OPEN	OPEN	NONE	NONE

NOTES:  
 1. + DENOTES TERMINAL VOIDED POSITION  
 ● DENOTES TERMINAL LOADED POSITION  
 | DENOTES POLARIZING RIB POSITION  
 2. HOUSING NUMBER FOR MOLEX REFERENCE ONLY

<b>SEE SHEET 1</b> SEC NO: P12016-0963 DRAWN BY: MURPHY CHKD: BG APPR: SHAMAHAN 2016/01/20	QUALITY SYMBOLS ▽=0 ▽=0	GENERAL TOLERANCES (UNLESS SPECIFIED) mm INCH 4 PLACES ±.--- ±.--- 3 PLACES ±0.05 ±.--- 2 PLACES ±0.10 ±.--- 1 PLACE ±0.2 ±.--- 0 PLACE ± ±.---	DIMENSION STYLE <b>MM ONLY</b>	SCALE <b>1:1</b>	DESIGN UNITS <b>METRIC</b>	THIRD ANGLE PROJECTION
	DRAWN BY DATE NMCNAMAR 2004/02/12	CHECKED BY DATE JDENNEHY 2004/02/13	APPROVED BY DATE BMAGUIRE 2004/02/16	MATERIAL NO. <b>SEE CHARTS</b>	DOCUMENT NO. <b>SD-91716-001</b>	SHEET NO. <b>10 OF 10</b>
	DRAFT WHERE APPLICABLE MUST REMAIN WITHIN DIMENSIONS					
	THIS DRAWING CONTAINS INFORMATION THAT IS PROPRIETARY TO MOLEX INCORPORATED AND SHOULD NOT BE USED WITHOUT WRITTEN PERMISSION					

## X-ON Electronics

Largest Supplier of Electrical and Electronic Components

*Click to view similar products for [Headers & Wire Housings](#) category:*

*Click to view products by [Molex](#) manufacturer:*

Other Similar products are found below :

[95000-104TRLF](#) [10135584-644402LF](#) [DF62W-EP2022PCA](#) [95000-106TRLF](#) [DF62W-2022SCA](#) [DF62W-EP2022PC](#) [2203348](#) [DF62W-2022SC](#) [1084018](#) [1029039](#) [1084017](#) [802-10-012-10-002000](#) [1112640](#) [1112639](#) [000-34000](#) [0009482033](#) [0009507031](#) [57102-S06-03LF](#) [57202-S52-04LF](#) [PCN6-15S-2.5E](#) [0039019024](#) [58102-G61-06LF](#) [582553-1](#) [0009508121](#) [0022285053](#) [0050291907](#) [018731A](#) [LY20-4P-DT1-P1E-BR](#) [02.125.8002.8](#) [60101931](#) [60598-1 \(Cut Strip\)](#) [M1625-3R/100](#) [61062-3](#) [61082-181009](#) [636-1427](#) [638009-1](#) [641938-9](#) [641991-4](#) [644168-1](#) [647662-1](#) [65039-019ELF](#) [65817-002LF](#) [65817-015LF](#) [65863-015LF](#) [66207-023LF](#) [67016-026LF](#) [67046-001LF](#) [67095-007LF](#) [67230-005LF](#) [68002-116](#)