

30V Dual N-channel MOSFET

Description

The SM4818 uses advanced trench technology to provide excellent $R_{DS(ON)}$ and low gate charge. This device is suitable for use as a load switch or in PWM applications.

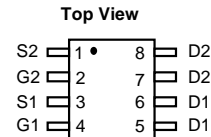



SOIC-8

General Features

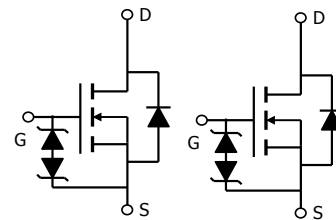
V_{DS}	30V
I_D (at $V_{GS}=10V$)	8A
$R_{DS(ON)}$ (at $V_{GS}=10V$)	<19m Ω
$R_{DS(ON)}$ (at $V_{GS} = 4.5V$)	< 23m Ω



◆ Ordering Information

Ordering Number		Package	Pin Assignment								Packing
Lead Free	Halogen Free		1	2	3	4	5	6	7	8	
SM4818PRL	SM4818SRG	SOP-8	S2	G2	S1	G1	D1	D1	D2	D2	Tape Reel
<p style="text-align: center;">SM4818 X X X</p> <p>(1) Package Type </p> <p>(2) Packing Type </p> <p>(3) Lead Free </p>			<p>(1) P: SOP-8</p> <p>(2) R: Tape Reel</p> <p>(3) G: Halogen Free; L: Lead Free</p>								

◆ Absolute Maximum Ratings ($T_A=25^\circ\text{C}$, unless otherwise noted)

Parameter	Symbol	Maximum	Units
Drain-Source Voltage	V_{DS}	30	V
Gate-Source Voltage	V_{GS}	± 20	V
Continuous Drain Current	I_D	$T_A=25^\circ\text{C}$	A
		$T_A=70^\circ\text{C}$	
Pulsed Drain Current ^c	I_{DM}	48	
Avalanche Current ^c	I_{AS}, I_{AR}	19	A
Avalanche energy $L=0.1\text{mH}$ ^c	E_{AS}, E_{AR}	18	mJ
Power Dissipation ^b	P_D	$T_A=25^\circ\text{C}$	W
		$T_A=70^\circ\text{C}$	
Junction and Storage Temperature Range	T_J, T_{STG}	-55 to 150	$^\circ\text{C}$

a: Fused current that based on wire numbers and diameter

b: Repetitive Rating: Pulse width limited by the maximum junction temperature

c: 1-in² 2oz Cu PCB board

◆ Electrical Characteristics ($T_A=25^\circ\text{C}$, unless otherwise noted)

Symbol	Parameter	Conditions	Min	Typ	Max	Units
STATIC PARAMETERS						
BV_{DSS}	Drain-Source Breakdown Voltage	$I_D=250\mu\text{A}, V_{GS}=0\text{V}$	30			V
I_{DSS}	Zero Gate Voltage Drain Current	$V_{DS}=30\text{V}, V_{GS}=0\text{V}$ $T_J=55^\circ\text{C}$			1	μA
					5	
I_{GSS}	Gate-Body leakage current	$V_{DS}=0\text{V}, V_{GS}=\pm 20\text{V}$			10	μA
$V_{GS(th)}$	Gate Threshold Voltage	$V_{DS}=V_{GS}, I_D=250\mu\text{A}$	1.2	1.8	2.4	V
$I_{D(ON)}$	On state drain current	$V_{GS}=10\text{V}, V_{DS}=5\text{V}$	30			A
$R_{DS(ON)}$	Static Drain-Source On-Resistance	$V_{GS}=10\text{V}, I_D=8\text{A}$ $T_J=125^\circ\text{C}$		15.5	19	m Ω
				21	25	
		$V_{GS}=4.5\text{V}, I_D=4\text{A}$		18.5	23	m Ω
g_{FS}	Forward Transconductance	$V_{DS}=5\text{V}, I_D=8\text{A}$		30		S
V_{SD}	Diode Forward Voltage	$I_S=1\text{A}, V_{GS}=0\text{V}$		0.75	1	V
I_S	Maximum Body-Diode Continuous Current				2.5	A
DYNAMIC PARAMETERS						
C_{iss}	Input Capacitance	$V_{GS}=0\text{V}, V_{DS}=15\text{V}, f=1\text{MHz}$	600	740	888	pF
C_{oss}	Output Capacitance		77	110	145	pF
C_{rss}	Reverse Transfer Capacitance		50	82	115	pF
R_g	Gate resistance	$V_{GS}=0\text{V}, V_{DS}=0\text{V}, f=1\text{MHz}$	0.5	1.1	1.7	Ω
SWITCHING PARAMETERS						
$Q_g(10\text{V})$	Total Gate Charge	$V_{GS}=10\text{V}, V_{DS}=15\text{V}, I_D=8\text{A}$	12	15	18	nC
$Q_g(4.5\text{V})$	Total Gate Charge		6	7.5	9	nC
Q_{gs}	Gate Source Charge			2.5		nC
Q_{gd}	Gate Drain Charge			3		nC
$t_{D(on)}$	Turn-On Delay Time	$V_{GS}=10\text{V}, V_{DS}=15\text{V}, R_L=1.8\Omega,$ $R_{GEN}=3\Omega$		5		ns
t_r	Turn-On Rise Time			3.5		ns
$t_{D(off)}$	Turn-Off Delay Time			19		ns
t_f	Turn-Off Fall Time			3.5		ns
t_{rr}	Body Diode Reverse Recovery Time	$I_F=8\text{A}, dI/dt=500\text{A}/\mu\text{s}$	6	8	10	ns
Q_{rr}	Body Diode Reverse Recovery Charge	$I_F=8\text{A}, dI/dt=500\text{A}/\mu\text{s}$	14	18	22	nC

Note: Pulse Test: Pulse Width $\leq 300\mu\text{s}$, Duty Cycles $\leq 2\%$

d: Guaranteed by design: not subject to production testing

TYPICAL ELECTRICAL AND THERMAL CHARACTERISTICS

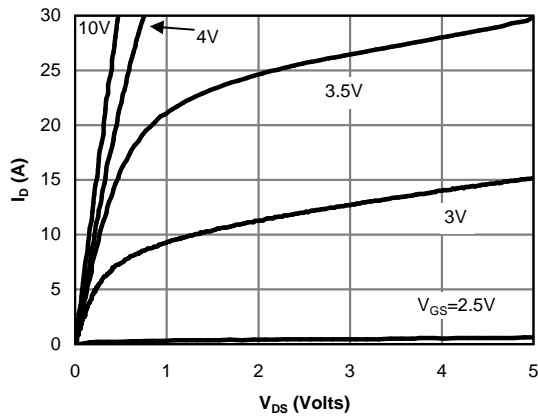

Figure 1: On-Region Characteristics (Note E)

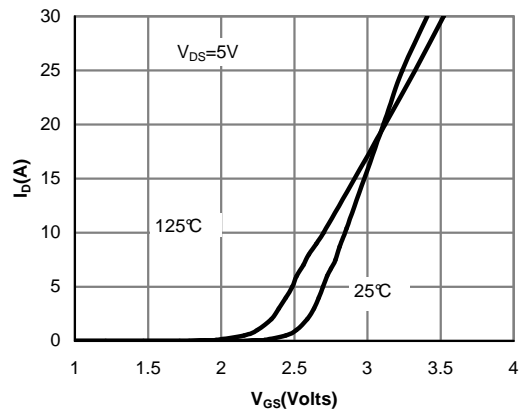

Figure 2: Transfer Characteristics (Note E)

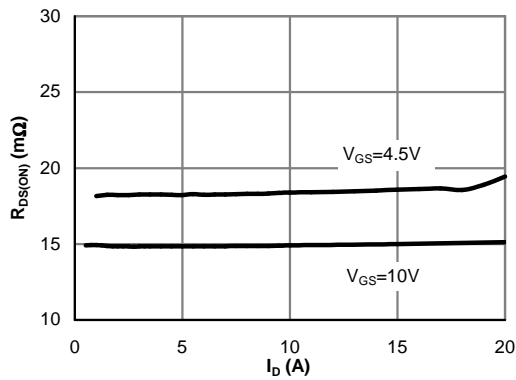

Figure 3: On-Resistance vs. Drain Current and Gate Voltage (Note E)

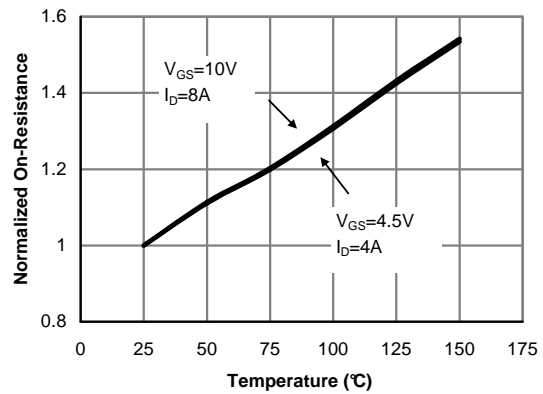

Figure 4: On-Resistance vs. Junction Temperature (Note E)

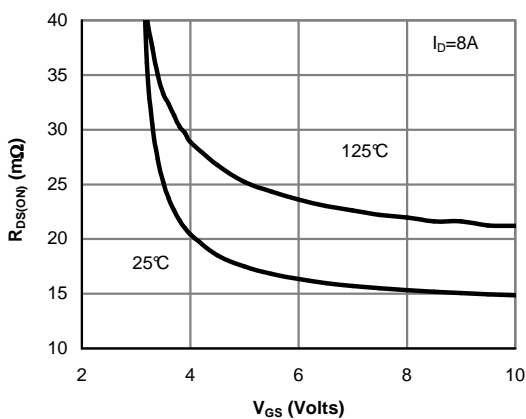

Figure 5: On-Resistance vs. Gate-Source Voltage (Note E)

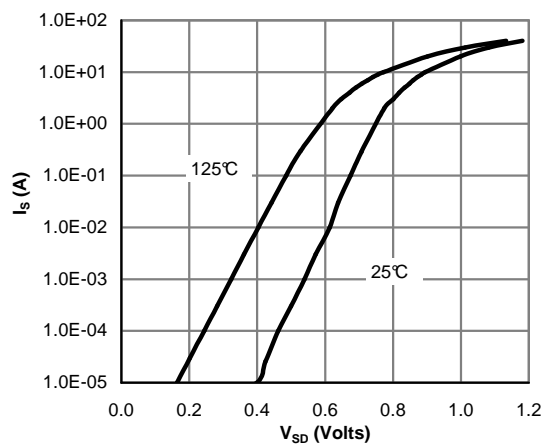

Figure 6: Body-Diode Characteristics (Note E)

TYPICAL ELECTRICAL AND THERMAL CHARACTERISTICS

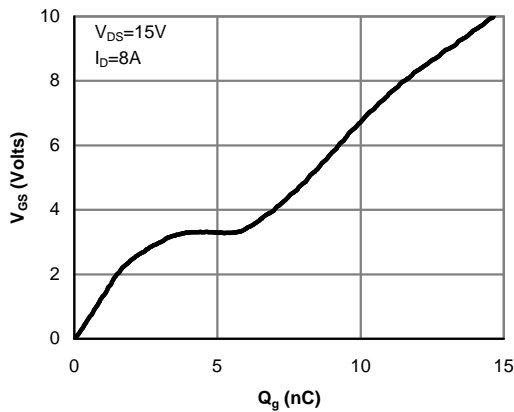

Figure 7: Gate-Charge Characteristics

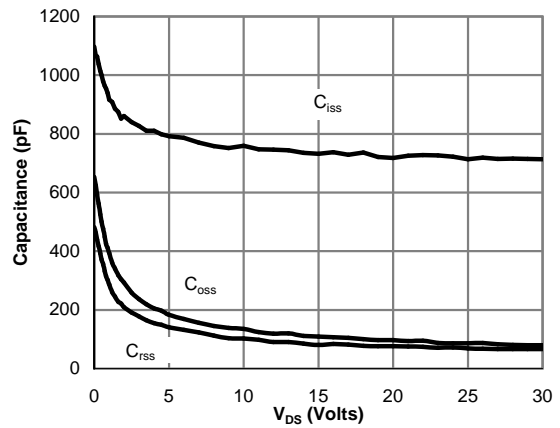

Figure 8: Capacitance Characteristics

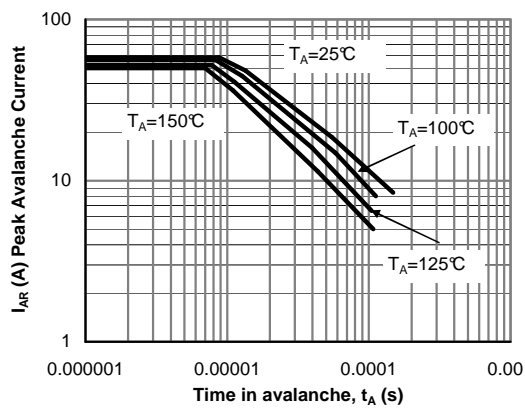

Figure 9: Single Pulse Avalanche capability (Note C)

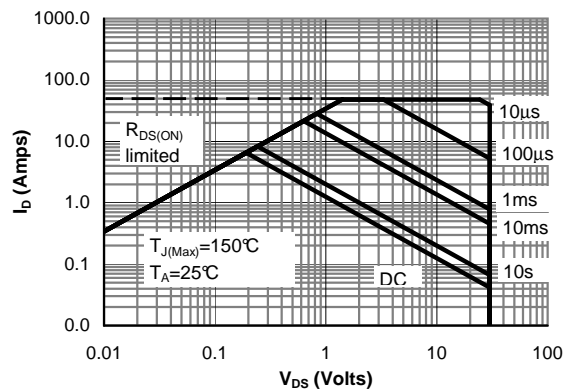

Figure 10: Maximum Forward Biased Safe Operating Area (Note F)

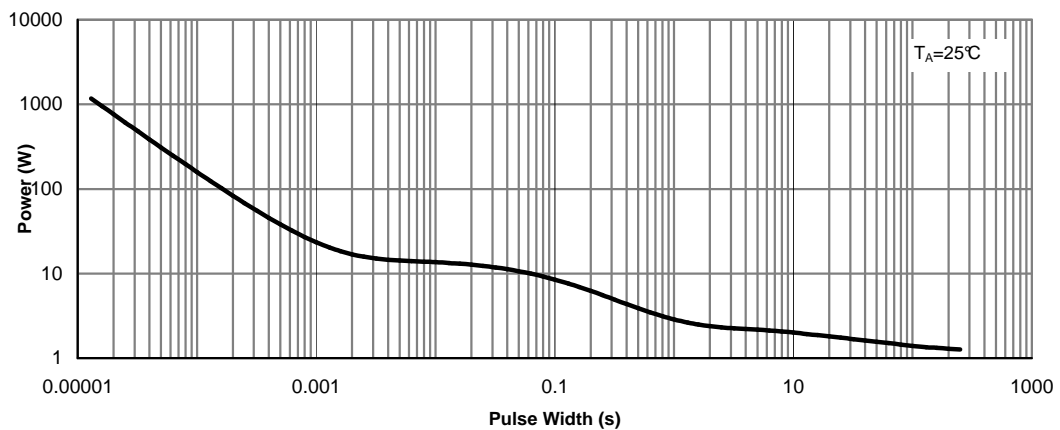

Figure 11: Single Pulse Power Rating Junction-to-Ambient (Note F)

TYPICAL ELECTRICAL AND THERMAL CHARACTERISTICS

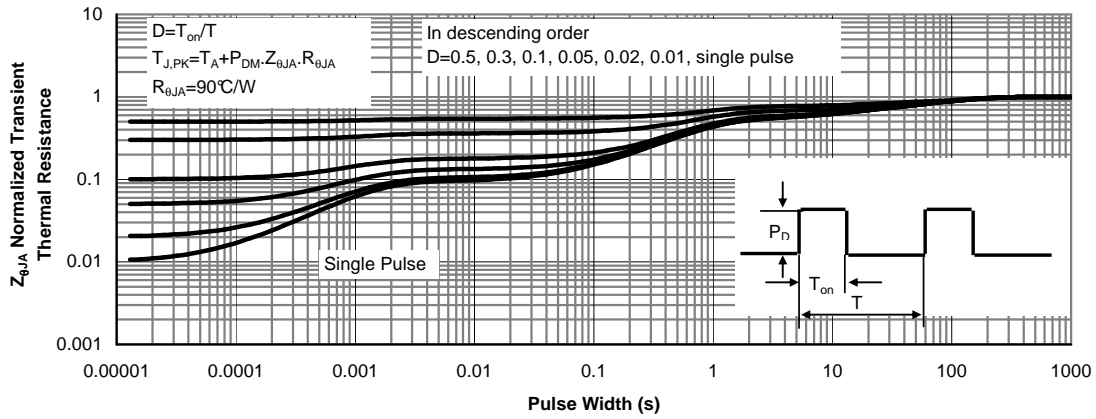
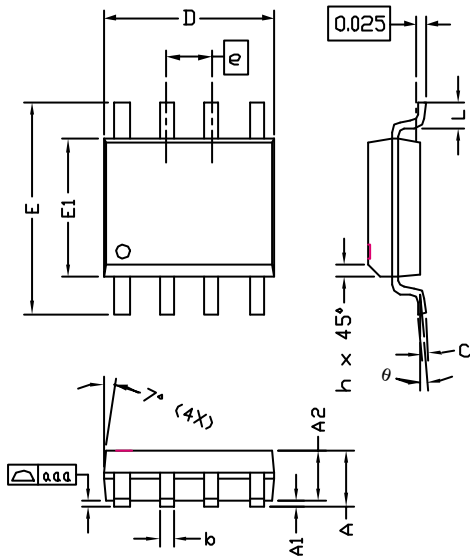

Figure 12: Normalized Maximum Transient Thermal Impedance (Note F)

SO-8 Package Data



SYMBOLS	DIMENSIONS IN MILLIMETERS			DIMENSIONS IN INCHES		
	MIN	NOM	MAX	MIN	NOM	MAX
A	1.45	1.50	1.55	0.057	0.059	0.061
A1	0.00	---	0.10	0.000	---	0.004
A2	---	1.45	---	---	0.057	---
b	0.33	---	0.51	0.013	---	0.020
c	0.19	---	0.25	0.007	---	0.010
D	4.80	---	5.00	0.189	---	0.197
E1	3.80	---	4.00	0.150	---	0.157
e	1.27 BSC			0.050 BSC		
E	5.80	---	6.20	0.228	---	0.244
h	0.25	---	0.50	0.010	---	0.020
L	0.40	---	1.27	0.016	---	0.050
aaa	---	---	0.10	---	---	0.004
θ	0°	---	8°	0°	---	8°

NOTE:

1. LEAD FINISH: 150 MICROINCHES (3.8 μ m) MIN.
THICKNESS OF Tin/Lead (SOLDER) PLATED ON LEAD
2. TOLERANCE \pm 0.100 mm (4 mil) UNLESS OTHERWISE SPECIFIED
3. COPLANARITY : 0.1000 mm
4. DIMENSION L IS MEASURED IN GAGE PLANE

X-ON Electronics

Largest Supplier of Electrical and Electronic Components

Click to view similar products for [MOSFET](#) category:

Click to view products by [SPS](#) manufacturer:

Other Similar products are found below :

[614233C](#) [648584F](#) [MCH3443-TL-E](#) [MCH6422-TL-E](#) [FDPF9N50NZ](#) [FW231A-TL-E](#) [APT5010JVR](#) [NTNS3A92PZT5G](#) [IRF100S201](#)
[JANTX2N5237](#) [2SK2464-TL-E](#) [2SK3818-DL-E](#) [FCA20N60_F109](#) [FDZ595PZ](#) [STD6600NT4G](#) [FSS804-TL-E](#) [2SJ277-DL-E](#) [2SK1691-DL-](#)
[E](#) [2SK2545\(Q,T\)](#) [D2294UK](#) [405094E](#) [423220D](#) [MCH6646-TL-E](#) [TPCC8103,L1Q\(CM](#) [367-8430-0972-503](#) [VN1206L](#) [424134F](#) [026935X](#)
[051075F](#) [SBVS138LT1G](#) [614234A](#) [715780A](#) [NTNS3166NZT5G](#) [751625C](#) [873612G](#) [IRF7380TRHR](#) [IPS70R2K0CEAKMA1](#)
[RJK60S3DPP-E0#T2](#) [RJK60S5DPK-M0#T0](#) [APT5010JVFR](#) [APT12031JFLL](#) [APT12040JVR](#) [DMN3404LQ-7](#) [NTE6400](#) [JANTX2N6796U](#)
[JANTX2N6784U](#) [JANTXV2N5416U4](#) [SQM110N05-06L-GE3](#) [SIHF35N60E-GE3](#) [2SK2614\(TE16L1,Q\)](#)