



RoHS Compliant  
Directive 2011/65/EU

# SPECIFICATION

Customer: RIC-VIVO

Item:	Crystal Unit
Type:	NX1612SB
Nominal Frequency:	38.4 MHz
Customer's Spec. No.:	---
NDK Spec. No.:	EXS00A-CS10526

Receipt

Revision Record						
Rev.	Date	Items	Contents	Approved	Checked	Drawn
---	27. Mar. 2017	issue	---	I. Miyahara	---	Y. Takaki
---	05. Jun. 2017	9.5. Reliability Item	Change : Reliability Assurance Item According to Customer's request.	I. Miyahara	---	Y. Takaki

1. Customer's Spec. No. : ---
2. NDK Spec. No. : EXS00A-CS10526
3. Type : NX1612SB

## 4. Electrical Specifications

	Parameters	SYM.	Electrical Spec.				Notes
			Min	TYP	MAX	Units	
1	Nominal frequency	$f_{nom}$	38.4			MHz	-
2	Overtone order	-	Fundamental			-	AT-CUT
3	Frequency tolerance	-	-10	-	+10	ppm	at +25°C
4	Frequency versus temperature characteristics	-	-12	-	+12	ppm	at -30~+85°C The reference temperature shall be +29°C
5	Equivalent resistance	-	-	-	30	$\Omega$	IEC $\pi$ -Network / Series
6	Load capacitance	$C_L$	-	8	-	pF	IEC $\pi$ -Network
7	Level of drive	DL	10	-	200	$\mu$ W	-
8	Inflection point	T0	27.5	29	30.5	°C	
9	Constant range	C0	-10	-	10	ppm	
10	1 <sup>st</sup> order curve fitting parameter	C1	-0.40	-	-0.1	ppm/°C	
11	2 <sup>nd</sup> order curve fitting parameter	C2	-4.5	-	4.5	$\times 10^{-4}$ ppm/°C <sup>2</sup>	
12	3 <sup>rd</sup> curve fitting parameter	C3	8.5	-	11.5	$\times 10^{-5}$ ppm/°C <sup>3</sup>	
13	Pulling Sensitivity	PS	10	-	16	ppm/pF	CL=8pF/ Not grounded This value is calculated by following formula. $PS = [ppm/pF] = \frac{C_m \times 1000}{2(C_p + C_L)^2}$ Unit: $C_p$ (pF), $C_m$ (fF) and $C_L$ (pF)
14	Quality factor (Q)	-	75,000	-	-	-	-
15	Spurious mode series resistance	-	1,100	-	-	$\Omega$	$\pm 1$ MHz
16	Aging	-	-0.7	-	0.7	ppm	1 <sup>st</sup> year
17	Frequency drift after reflow	-	-2	-	2	ppm	after two reflow passed.
18	Insulation resistance	-	500	-	-	M $\Omega$	Terminal to terminal insulation resistance also terminal to cover insulation resistance when DC100V $\pm 15$ V is applied.
19	Operating temperature range	-	-30	-	+105	°C	-
20	Storage temperature range	-	-40	-	+105	°C	-
21	Air-tightness	-	-	-	$1.1 \times 10^{-9}$	Pa m <sup>3</sup> /s	Helium leak detector
22	MSL	-	-	-	-	-	MSL 1
23	ESD(HBM)	-	-	-	1000	V	Guarantee voltage
24	ESD(MM)	-	-	-	200	V	Guarantee voltage

5. Drive level dependency (DLD) : Measurement method and specs are defined below.

Measurement condition		Freq.	ESR
Drive level	0.01uW to 100uW to 0.01uW		
Number of points	29 points (15 points up, 15 points down)		
Max. – Min. spec.	Difference between max and min in two way measurement. Freq.: $F_{MAX}-F_{MIN}$ ESR: $(ESR_{MAX}-ESR_{MIN})/ESR_{MIN}$	<3ppm	<20%
Repeatability spec.	Repeatability of two way measurement in above condition. Freq.: $F_2-F_1$ ESR: $(ESR_2-ESR_1)/ESR_1$ ESR <sub>1</sub> : first measurement on each drive levels ESR <sub>2</sub> : second measurement on each drive levels	<0.7ppm	<10%

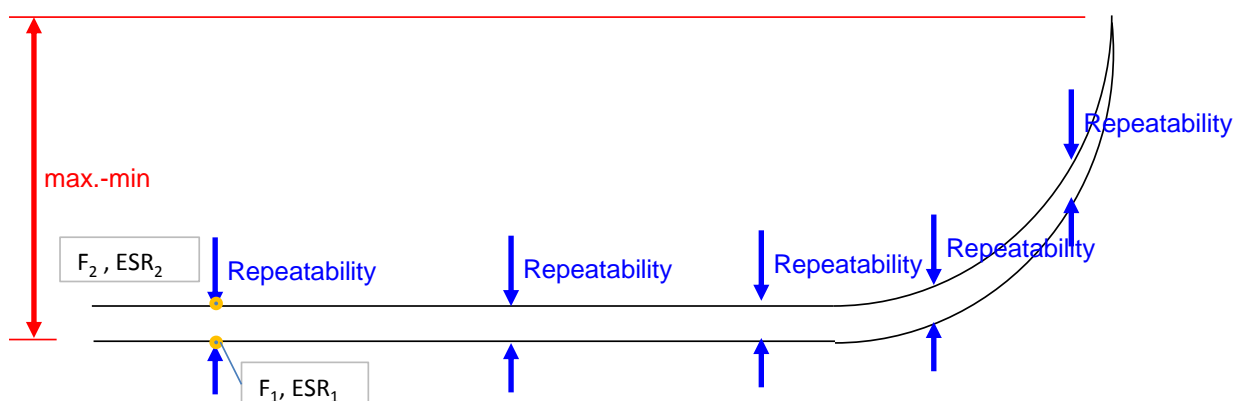

6. 1. Residual frequency stability slope : ±50 ppb/°C Max.

Condition 1A - Test condition (continuous temperature rate change of ~1.0°C/min)

- The residual is defined as the difference between the crystal measured FT curve and the 5<sup>th</sup> order polynomial fit of the FT curve. Frequency is measured between -30 to +85°C every 1°C. Residual slope is calculated by the formula below.

$$FIT\Delta f(t_N) = a(t_N - t_0)^5 + b(t_N - t_0)^4 + c(t_N - t_0)^3 + d(t_N - t_0)^2 + e(t_N - t_0) + f$$

$$t_1 = -30, t_2 = -29 \dots t_{114} = +84, t_{115} = +85^\circ C$$

$$t_0 = +29^\circ C$$

$$RES(t_N) = F(t_N) - FIT\Delta f(t_N)$$

$$RES\_SLP = RES(t_{N+1}) - RES(t_N)$$

6.2. 5°C small hysteresis 1 : ±50 ppb/°C Max. Ta = -30 to +85°C

Condition1B test condition (continuous temperature rate change of ~1.0°C/min.)

- Measure FT points every 0.5°C while cycling temperature over a 5°C small temperature orbit, an example 5°C small orbit temperature cycle is +30°C to +35°C to +30°C.
- During every individual heating/cooling cycle there should be 11 points; discard the first point of each heating and cooling cycle; this leaves 10 points for each heating and cooling cycle.
- Subtract the fifth-order polynomial best fit from 1A for each of the 10 points, and

then calculate the slope of the residual for each of these heating and cooling 10 point curves.

- The residual slope should be within +/-50 ppb/°C.

6.3. 5°C small orbit hysteresis 2 : 100 ppb (magnitude) peak-peak. Ta = -30 to +85°C

Condition 2 test condition (continuous temperature rate change of ~1.0°C/min.)

- Measure FT points every 0.5°C while cycling temperature over a 5°C small temperature orbit, an example 5°C small orbit temperature cycle is +30°C to +35°C to +30°C.
- During every individual heating/cooling cycle there should be 11 points; discard the first and last point of each heating and cooling cycle, which results in 9 temperature points. Calculate the average measured peak-to-peak frequency difference for these 9 temperature points.
- The average difference is the magnitude of the small orbit hysteresis 2.
- The temperature is based on thermistor.

## 7. Thermistor characteristics

7.1. Size	: 0.6×0.3×0.15 (mm)
7.2. Resistance value (at +25°C)	: 100 (kΩ) ±1%
7.3. B Constant (+25/+50°C)	: 4250 (K) ±1%
7.4. Rated power (at 25°C)	: 100 (mW) Max.

## 8. Examination results document

Since a performance is guaranteed, an examination results document does not submit.

## 9. Application drawing

9.1. Dimension Drawing	: EXD14B-00597
9.2. Taping and Reel figure	: EXK17B-00405
9.3. Holder Marking	: EXH11B-00319
9.4. Packing Label	: EXK17B-00422
9.5. Reliability assurance Item	: EXS30B-01030

## 10. Notice

10.1 Order items are manufactured according to specification. As to conditions, which are not indicated in this specification and unpredictable such as applied condition and oscillation margin, please check them beforehand.

10.2 Unless we receive request for modification within 3 weeks from the issue date of this NDK specification sheet, we will supply products according to this specification. Also, if you'd like to modify specification of order, which has been placed with delivery request within 3 weeks from the issue data of this specification sheet, we would like to discuss with you separately.

10.3 In no event shall the company be liable for any product failure resulting from an inappropriate handling or operation of the product beyond the scope of its guarantee.

10.4 Where any change to the process condition is made due to the change(s) in the production line, inform personnel of the specifications.

10.5 Should this specification data give rise to any disputes relating to any intellectual property rights or any other rights of a third person, the company shall not indemnify anyone for any damage.

Their disclosure must not be construed as the grant of a license to use any of the intellectual property

rights owned by the company.

10.6 If you intend to use products listed on this specification for applications that may result in loss of life or assets (controls relating to safety, medical equipment, aeronautical equipment, space equipment, etc.), please do not fail to advise us of your intention beforehand.

10.7 In the company's production process whatever amount of ozone depleting substances (ODS) as specified in the Montreal protocol is not used.

10.8 Information contained in this specification must not be quoted, reproduced or used for other purposes including processing either in part or in full without obtaining prior approval from the company.

10.9 The appearance color and so on have a different case by purchasing it more than 2 suppliers of the component, but characteristic and reliability are guaranteed.

10.10 In case of the product long time keep at high temperature and humidity, may affect product characteristic (solder ability) and a packing condition.

Please keep at storage condition of temperature +5°C ~+35°C, humidity ~85%RH.

10.11 Crystal units will be damaged by ultrasonic welding process due to resonance of crystal wafer itself. NDK does not recommend using ultrasonic welding. If Ultra Sonic welding used, NDK strongly recommend verifying crystal unit damage by ultrasonic weld.

#### 11. Prohibited items

Be sure to use the product under the following conditions. Otherwise, the characteristics deterioration or destruction of the product may result.

##### (1) Reflow soldering heat resistance

Peak temperature: 265°C, 10 sec

Heating: 230°C or higher, 40 sec

Preheating: 150°C to 180°C, 120 sec

Reflow passage times: twice

##### (2) Manual soldering heat resistance

Pressing a soldering iron of 400°C on the terminal electrode for four seconds (twice).

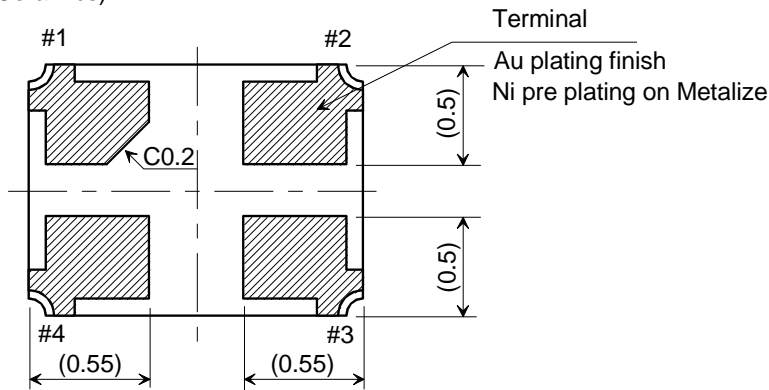
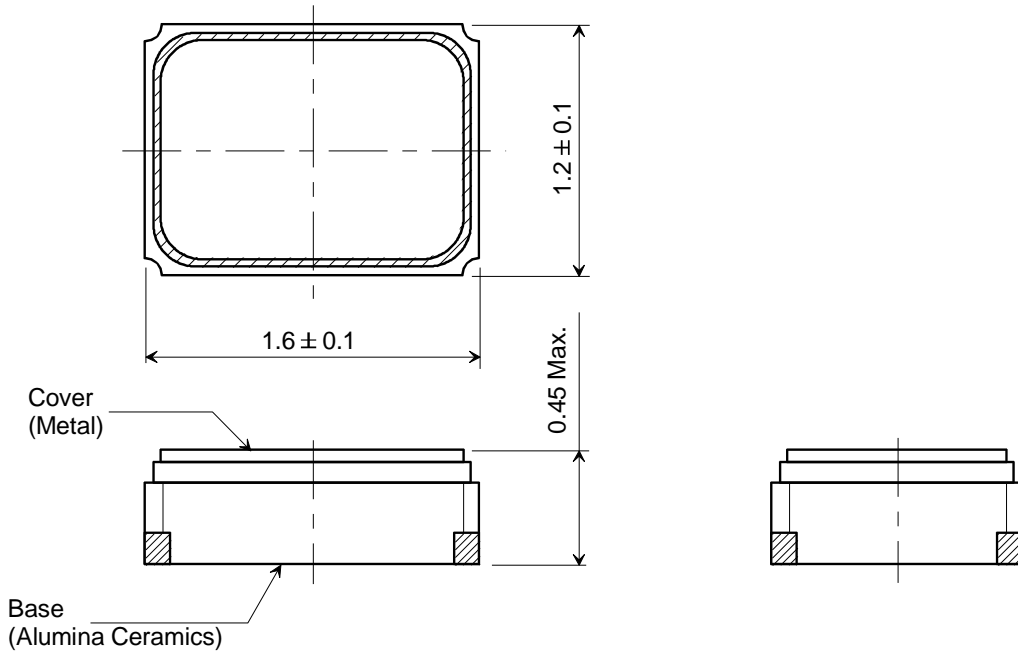

LAND PATTERN (TYPICAL)

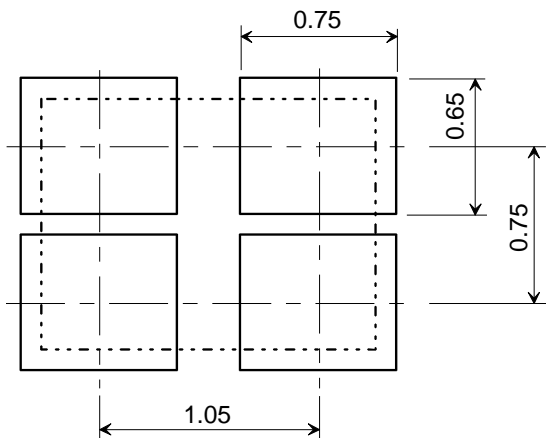

TOP VIEW  
Terminal land connections

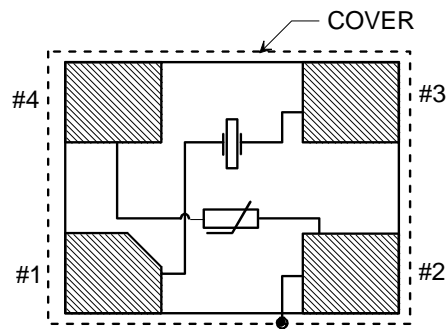

#1, #3: Crystal  
#2: Thermistor and GND (Connection with cover)  
#4: Thermistor

Date of Revise	Charge	Approved	Reason
---	---	---	---
Date	Name	Third Angle Projection	Tolerance
26. Jul. 2013	Y. Takaki	Dimension:mm	----
Date	Name	Title	Scale
26. Jul. 2013	Y. Takaki	NX1612SB Dimension Drawing	--/--
Date	Name		Drawing No.
26. Jul. 2013	---		EXD14B-00597(1/2)
Date	Name	Rev.	
26. Jul. 2013	Y.Yamauchi	---	

**NIHON DEMPA KOGYO CO., LTD.**

LAND PATTERN (TYPICAL)

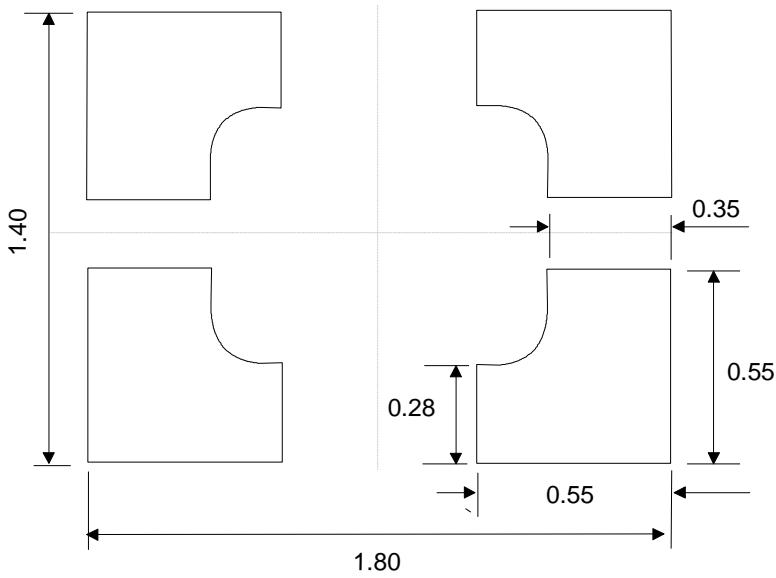

stencil pattern (TYPICAL)

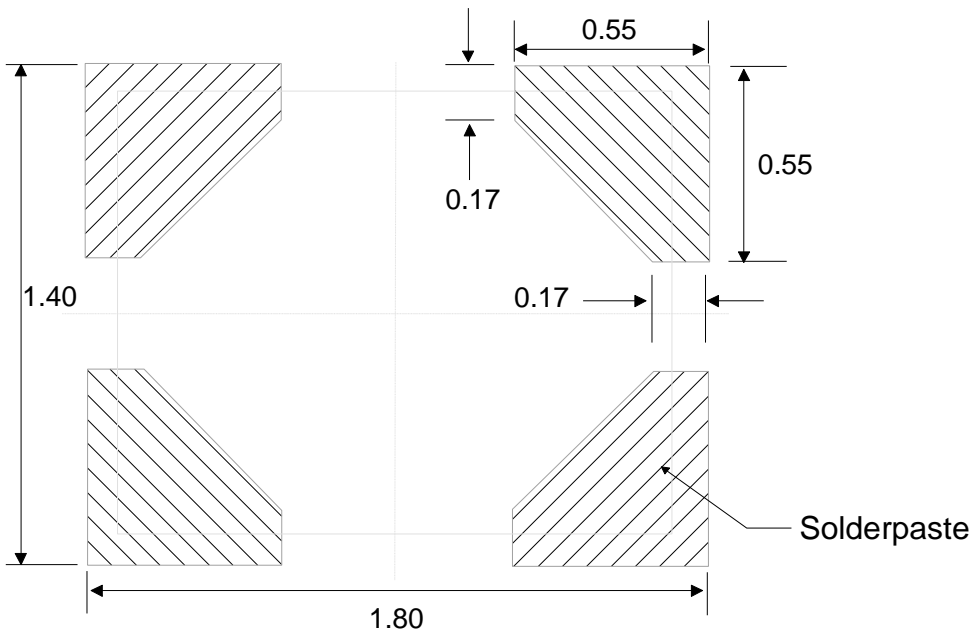

Date of Revise	Charge	Approved	Reason
---	---	---	---
Date	Name	Third Angle Projection	Tolerance
26. Jul. 2013	Y. Takaki	Dimension:mm	----
Date	Name	Title	Scale
26. Jul. 2013	---	NX1612SB Dimension Drawing	--/--
Date	Name		Drawing No.
26. Jul. 2013	Y.Yamauchi		EXD14B-00597(2/2)
Rev.	---		

**NIHON DEMPA KOGYO CO., LTD.**

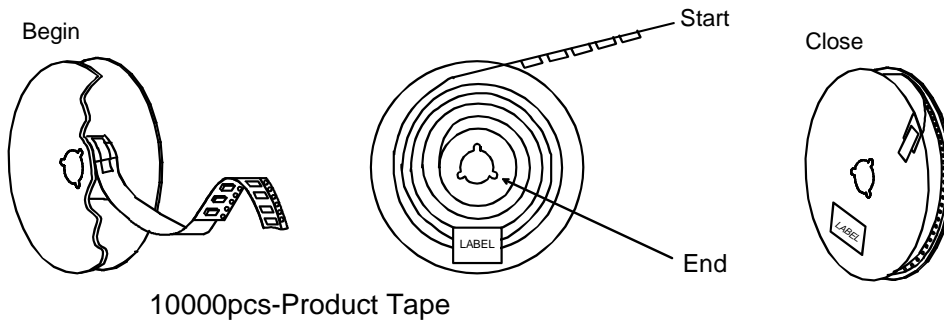
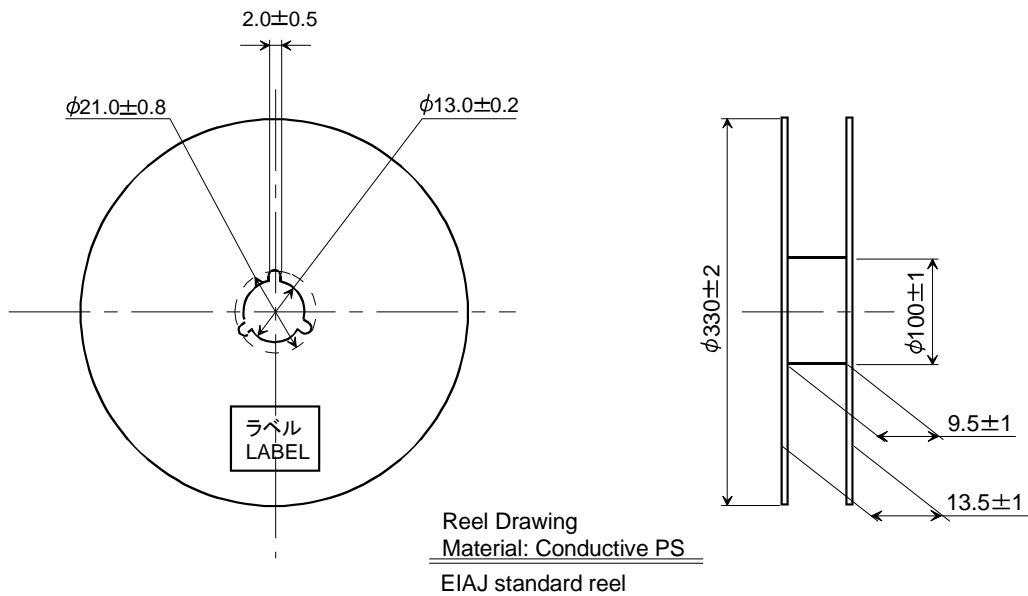
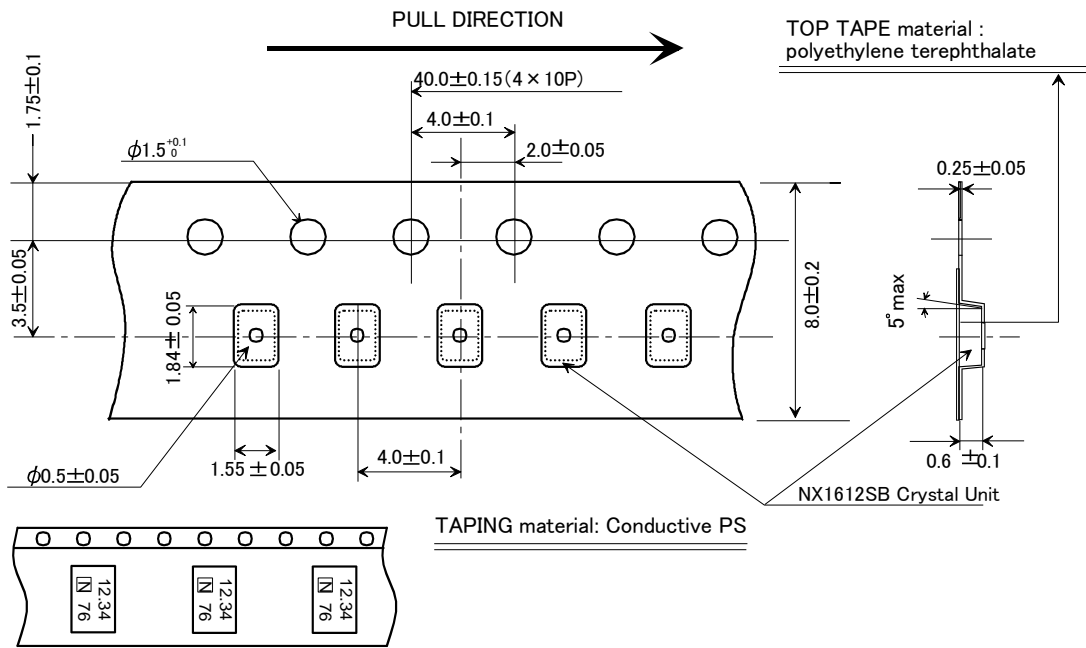

	Date of Revise	Charge	Approved	Reason
A	19 Oct. 2015	H. Ohkubo	H. Murakoshi	Correction of the error.
	Date	Name	Third Angle Projection	Tolerance
Drawn	16 Oct. 2015	H. Ohkubo	Dimension:mm	Scale
Designed	16 Oct. 2015	H. Ohkubo	Title	Rev.
Checked	-----	-----	NX1612SB Taping and Reel Spec.	A
Approved	16 Oct. 2015	H. Murakoshi		

NIHON DEMPA KOGYO CO., LTD.



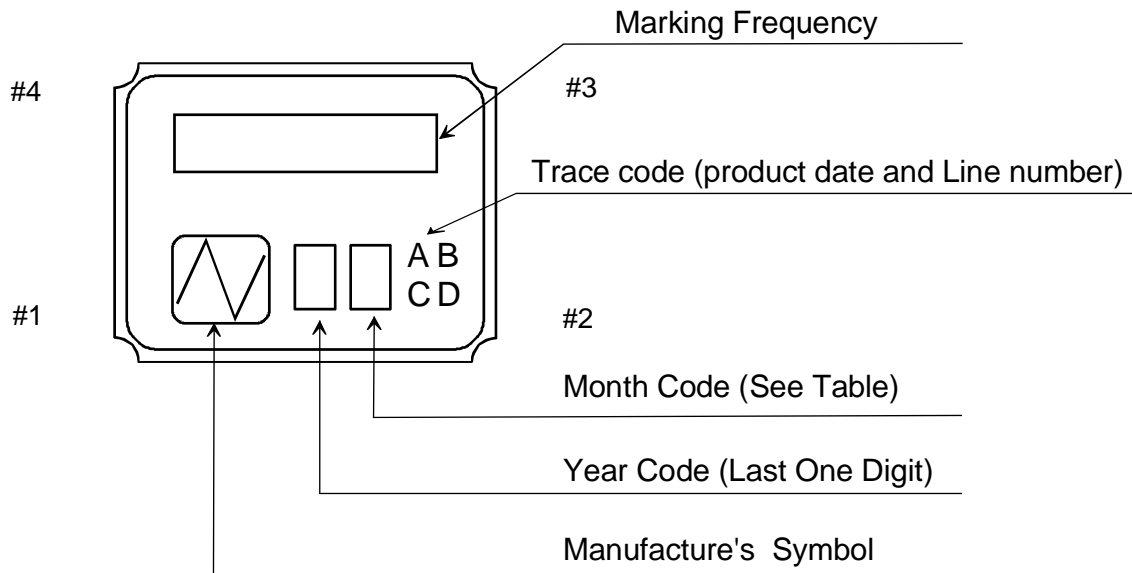

NOTE

1. Month Code Table

Month	1 Jan.	2 Feb.	3 Mar.	4 Apr.	5 May.	6 Jun.	7 Jul.	8 Aug.	9 Sep.	10 Oct.	11 Nov.	12 Dec.
Month Code	1	2	3	4	5	6	7	8	9	X	Y	Z

\*Marking digits are not include a decimal point and dot mark.

	Date of Revise	Charge	Approved	Reason	
A	10. Jul. 2008	T.Asamizu	K.Kubota	Delete application period.	
	Date	Name	Third Angle Projection	Tolerance	Scale
Drawn	14. Feb. 2006	T.Asamizu	Dimension:mm		/
Designed	14. Feb. 2006	T.Asamizu	Title <b>Crystal Holder Marking</b>	Drawing No. <b>EXH11B-00319</b>	Rev.
Checked	14. Feb. 2006	I.Miyahara			A
Approved	14. Feb. 2006	K.Okamoto			

**NIHON DEMPA KOGYO CO., LTD.**

**Reliability assurance item (1/1)**

(page: 1/2)

No.	Test Item	Test Methods	Spec. Code
1	High temperature	Temperature: +125 °C Test time: 1000 Hr.	A, B
2	Cold resistance	Temperature: -40 °C Test time: 1000 Hr.	A, B
3	Humidity	at +85 °C with 80 to 85 % RH for 1000 hr.	A, B
4	Thermal shock (TS)	-40±3°C / +125±3°C 300Cycle/1H per cyc.	A, B
5	Thermal cycle(TC)	-40±3°C / +125±3°C 300Cycle/1H per cyc.	A, B
6	Vibration	Frequency Range	10 to 2000Hz
		Amplitude or Acceleration	1.55 mm or 100m/s <sup>2</sup>
		Test time	3 axis each 2H.
7	Bending	Test board	100mm x 40mm x 1.6mm
		Test time	bending 5mm (1mm/s) , Time 5 sec
8	Shock 1	Shock	Device are put on the weight of 200 g onto concrete..
		Height	1.8 m
		Drop times	3 times for each six side derrection and four corner. Totally 30 drops.
9	Shock 2	Shock	Device are put on the weight of 200g and concrete.
		Height	1.0 m
		Drop times	300 drops . 12drops/ min.
10	Blank Shear Test	Pull the center of crystal blank vertically.	---
11	Reflow resistance	Temperature cycle as shown in (Fig2.) for 3 cycle.	A, B
12	Air Tightness	Helium leak test.	C
13	瞬停 Test	Devices are shocked to half sine wave (10,000G) six mutually perpendicular axis each 3 times.	D

Specification code	Specification
A	$\Delta F/F \leq \pm 2.0$ ppm $\Delta CI \leq \pm 20$ % or $\pm 15 \Omega$ greater value
B	Thermistor resistance: $\Delta R/R \leq 5\%$
C	No leak
D	No 瞬停

**Reliability assurance item (2/2)**

Recommended reflow profile

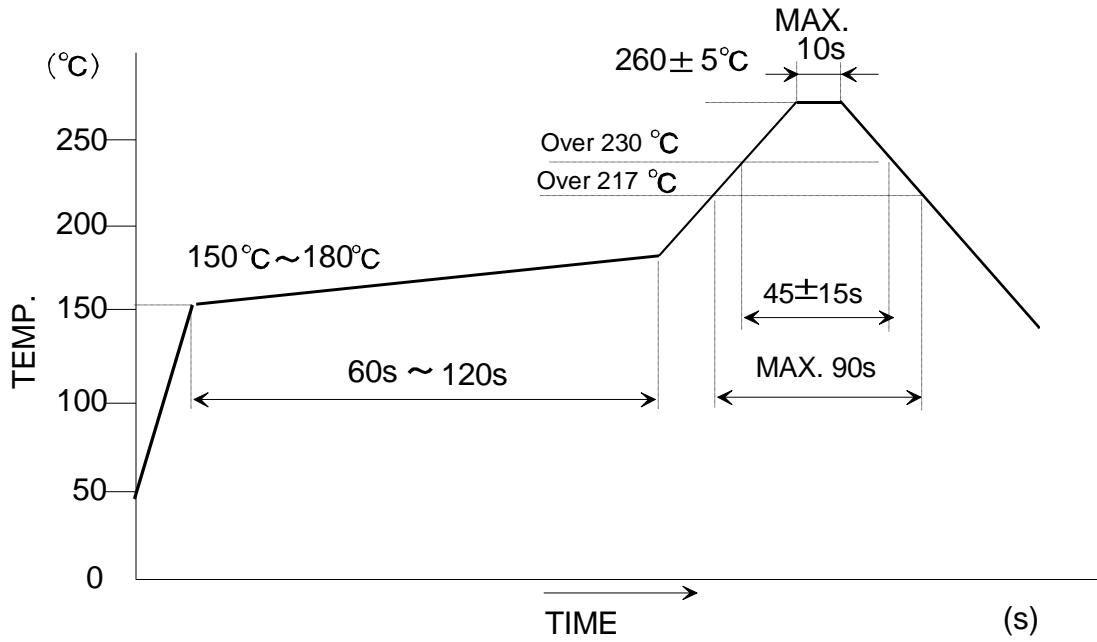

- A: 150 to 180 °C ( 90 ± 30 sec. )
- B: 230°C min. ( 45 ± 15 sec. )
- C: Peak temperature. 260°C ± 5 °C (10sec. max.)
- D: 217 °C Min. (90 sec. max.)

## X-ON Electronics

Largest Supplier of Electrical and Electronic Components

*Click to view similar products for [Crystals category](#):*

*Click to view products by [Nihon Dempa Kogyo manufacturer](#):*

Other Similar products are found below :

[CS325S24000000ABJT](#) [718-13.2-1](#) [MC405 32.0000K-R3:PURE SN](#) [FC-135R 32.7680KF-A3](#) [7A-40.000MAAE-T](#) [7B-27.000MBBK-T](#)  
[FL2000085](#) [9B-15.360MBBK-B](#) [9C-7.680MBBK-T](#) [ASH7K-32.768KHZ](#) [AT-41.600MAGQ-T](#) [BTD1062E05A-513](#) [LFX TAL066198Cutt](#)  
[9C-14.31818MBBK-T](#) [FA-238 50.0000MB30X-K3](#) [FC-12M 32.7680KA-AC3](#) [SSPT7F-9PF20-R](#) [FX325BS-38.88EEM1201](#)  
[LFX TAL065253Cutt](#) [LFX TAL066431Cutt](#) [XT9S20ANA14M7456](#) [XT9SNLANA16M](#) [646G-24-2](#) [7A-24.576MBBK-T](#) [7B-30.000MBBK-T](#)  
[WX26-32.768K-6PF](#) [9B-14.31818MBBK-B](#) [CD1AM](#) [7B-25.000MAAE-T](#) [7A-14.31818MBBK-T](#) [6504-202-1501](#) [6526-202-1501](#) [FA-118T](#)  
[27.1200MB50P-K0](#) [FC-135R 32.7680KA-A3](#) [ABM12-104-37.400MHZT](#) [ABLS-10.000MHZ-D3W-T](#) [BTJ112E01E-513](#) [BTJ722K01C-7067](#)  
[BTL-20-513](#) [TSX-3225 24.0000MF15X-AC](#) [TSX-3225 16.0000MF18X-AC](#) [BTJ120E02C](#) [BTL-12-513](#) [7A-10.000MBBK-T](#) [7A-](#)  
[11.0592MBBK-T](#) [ABM12-103-24.000MHZT](#) [CS325S25000000ABJT](#) [ABM3B-25.000MHZ-B2-X-T](#) [FC-135 32.7680KA-A5](#) [FX0800015](#)