

## PRODUCT SPECIFICATION

No. T-1-2189 (R-1-2189)	Date Issued: February 7, 2005	
Customer: GENERAL	Revised: B	Date Revised: August 5, 2016
Title Subject: VH Connector (Phosphor bronze) Lead-free product		Issued by: Osaka Engineering Center

This product specification contains the results of performance tests for the VH Connector (Phosphor bronze) Lead-free product.

– Index –

1. PART NAME, PART NUMBER & DRAWING NUMBER
2. CONSTRUCTION, DIMENSIONS, MATERIAL & SURFACE FINISH
3. CHARACTERISTICS
4. ABOUT WHISKER
5. SPECIMEN
6. TEST CONDITIONS
7. REQUIREMENTS, TEST METHODS & TEST RESULTS
  - 7.1 Appearance
  - 7.2 Mechanical Performance Test
    - 7.2.1 Insertion Force (I.F.) & Withdrawal Force (W.F.)
    - 7.2.2 Crimp Tensile Strength
    - 7.2.3 Contact Insertion Force
    - 7.2.4 Contact Retention Force
    - 7.2.5 Post Retention Force
    - 7.2.6 Housing Lock Strength
  - 7.3 Electrical Performance Test
    - 7.3.1 Contact Resistance
    - 7.3.2 Current Continuity
    - 7.3.3 Insulation Resistance
    - 7.3.4 Dielectric Withstanding Voltage
  - 7.4 Environmental Test
    - 7.4.1 Durability
    - 7.4.2 Humidity
    - 7.4.3 Heat Aging
    - 7.4.4 Thermal Shock
    - 7.4.5 Hydrogen Sulfide Gas
    - 7.4.6 Salt Spray
    - 7.4.7 Vibration
    - 7.4.8 Ammonia Gas
  - 7.5 Solder Test (Header)
    - 7.5.1 Solderability
    - 7.5.2 Resistance to Soldering Heat



This is our exclusive property. It is not to be copied, reprinted or disclosed to a third party, not used for manufacturing, without our written consent, and has to be returned to us.

Prepared by: <u>M. Ueda</u>	Checked by: <u>M. Igarashi</u>	Reviewed by: <u>N. Tsuji</u>	Approved by: <u>H. Tomimoto</u>
--------------------------------	-----------------------------------	---------------------------------	------------------------------------

This is our exclusive property. It is not to be copied, reprinted or disclosed to a third party, not used for manufacturing, without our written consent, and has to be returned to us.

Title Subject: VH Connector (Phosphor bronze) Lead-free product	No. T-1-2189 (R-1-2189)	Revised: B
--	----------------------------	------------

**1. PART NAME, PART NUMBER & DRAWING NUMBER**

Part Name		Part Number	Drawing Number
Contact		SVH-21T-P1.1	KRD-4711-3
Housing		VHR-*N	KRD-3934-4
		VHR-*M	KRD-7716-3
Header	Top entry type	B*P-VH (LF)(SN)	KRD-35487
	Side entry type	B*PS-VH (LF)(SN)	KRD-35490
		S2P-VH (LF)(SN)	KRD-35492
		S3P-VH (LF)(SN)	
		S4P-VH (LF)(SN)	
		S5P-VH (LF)(SN)	
		S6P-VH (LF)(SN)	
S7P-VH (LF)(SN)			

Note<sub>1</sub>: Number of circuits in one or two-digit figures is indicated in \*.

Note<sub>2</sub>: (LF)(SN) as identification part number indicating pure tin-plated specification of lead-free shall be displayed on a label until all products are shifted to the lead-free.

**2. CONSTRUCTION, DIMENSIONS, MATERIAL & SURFACE FINISH**

Construction and dimensions shall be in accordance with the referenced drawings. Material and surface finish shall be as specified below.

Part Name		Material	Surface Finish, etc.
Contact		Phosphor bronze	Tin-plated
Housing		PA 6	UL94V-0
Header	Post	Brass	Copper-underplated Tin-plated
	Wafer	PA 66	

**3. CHARACTERISTICS**

Item		Rated Value
Current rating		7 A (AC, DC) (Note <sub>3</sub> )
Voltage rating		250 V (AC, DC)
Temperature range		-25 to +85 °C (Note <sub>4</sub> )
Applicable wire	Conductor size	AWG #22 to #18
	Insulation O.D.	φ1.7 to φ3.0 mm
	Conductor spec.	Tin-plated annealed copper wire (stranded wire)
Recommended printed circuit board (PCB)	Thickness	1.6 mm
	Hole size	1.65 +0.1/-0 mm (Note <sub>5</sub> )

Note<sub>3</sub>: When AWG #18 applied.

Note<sub>4</sub>: Including temperature rise in applying electrical current.

Note<sub>5</sub>: Recommended values when paper based epoxy resin PCB with drilled hole is used. Tolerance changes depending on PCB material and piercing method.

This is our exclusive property. It is not to be copied, reprinted or disclosed to a third party, not used for manufacturing, without our written consent, and has to be returned to us.

Title Subject: VH Connector (Phosphor bronze) Lead-free product	No. T-1-2189 (R-1-2189)	Revised: B
--	----------------------------	------------

**4. ABOUT WHISKER**

Although the lead-free plating of this product has performed re-flow tin plating which ensures maximum effectiveness for retarding whisker growth, it is not possible to completely eliminate the whisker problem.

**5. SPECIMEN**

Part Name		Part Number
Contact		SVH-21T-P1.1
Housing		VHR-*N VHR-*M
Header	Top entry type	B*P-VH (LF)(SN)
	Side entry type	B*PS-VH (LF)(SN)

Note<sub>6</sub>: Number of circuits in one or two-digit figure is indicated in \*.

Note<sub>7</sub>: VHR-\*M shall be used for the measurement of insulation resistance and dielectric withstanding voltage (between the outer surface of a housing and contact).

**6. TEST CONDITIONS**

- When tested in accordance with the test condition and method specified in each item, each requirement shall be met.
- Unless otherwise specified, tests shall be conducted under the following ambient conditions specified in JIS C 60068-1 (IEC 60068-1) [Basic Environmental Testing Procedures General and Guidance].

Temperature: 15 to 35 °C  
 Relative humidity: 25 to 75 %

- For environmental tests, as a rule, the specimen assembled for actual use and the wire of UL1007 style AWG #20 shall be used.

**7. REQUIREMENTS, TEST METHODS & TEST RESULTS**

**7.1 Appearance**

**Requirement:** There shall be no crack, deformation or discoloration which may affect the performance specified in this specification.

**Test method:** Visual inspection.

**Test result:** Good.

This is our exclusive property. It is not to be copied, reprinted or disclosed to a third party, not used for manufacturing, without our written consent, and has to be returned to us.

Title Subject: VH Connector (Phosphor bronze) Lead-free product	No. T-1-2189 (R-1-2189)	Revised: B
--	----------------------------	------------

7.2 Mechanical Performance Test

7.2.1 Insertion Force (I.F.) & Withdrawal Force (W.F.)

Requirement:

No. of circuits	At Initial		At 50th
	I.F. (max.)	W.F. (min.)	W.F. (min.)
2	19.6	3.9	2.0
3	29.4	5.9	2.9
4	39.2	7.8	3.9
5	44.1	9.8	4.9
6	53.9	12.7	6.9
7	58.8	15.7	8.8
8	68.6	18.6	10.8
9	73.5	21.6	12.7
10	78.4	24.5	14.7

UNIT: N

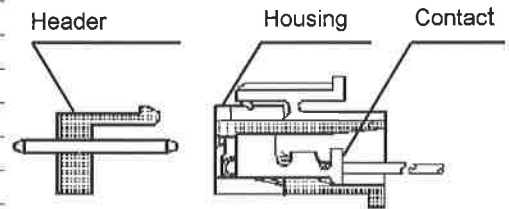

Test method: A housing with crimped contacts and a header shall be mated and unmated on the mating axis. Initial insertion and withdrawal forces and also withdrawal force at 50th shall be measured, releasing the housing lock. (Testing speed: 1 to 5 mm/sec.)

Test result:

No. of circuits	Items	UNIT: N		
		Ave.	Max.	Min.
2	Initial I.F.	12.34	13.3	11.6
	Initial W.F.	7.66	8.6	6.3
	W.F. at 50th	8.36	9.6	6.8
3	Initial I.F.	18.31	20.1	15.4
	Initial W.F.	12.11	14.6	9.3
	W.F. at 50th	12.32	14.6	8.8
4	Initial I.F.	24.91	27.8	20.6
	Initial W.F.	18.40	22.1	13.2
	W.F. at 50th	16.31	18.5	12.1
5	Initial I.F.	30.10	33.4	26.8
	Initial W.F.	23.15	27.1	19.8
	W.F. at 50th	20.04	23.1	17.1
6	Initial I.F.	36.18	39.9	31.7
	Initial W.F.	30.54	35.1	25.2
	W.F. at 50th	21.64	26.5	18.7
7	Initial I.F.	43.01	45.6	37.2
	Initial W.F.	33.10	36.8	27.1
	W.F. at 50th	27.20	33.4	23.9

n=10

This is our exclusive property. It is not to be copied, reprinted or disclosed to a third party, not used for manufacturing, without our written consent, and has to be returned to us.

Title Subject: VH Connector (Phosphor bronze) Lead-free product	No. T-1-2189 (R-1-2189)	Revised: B
--	----------------------------	------------

UNIT: N

No. of circuits	Items	Ave.	Max.	Min.
8	Initial I.F.	47.34	52.8	43.3
	Initial W.F.	37.06	40.3	33.4
	W.F. at 50th	32.93	38.0	28.4
9	Initial I.F.	53.70	58.2	46.9
	Initial W.F.	41.30	45.1	35.1
	W.F. at 50th	37.60	43.1	32.1
10	Initial I.F.	56.60	61.8	51.9
	Initial W.F.	43.40	47.7	39.9
	W.F. at 50th	43.08	48.3	35.3

n=10

### 7.2.2 Crimp Tensile Strength

Requirement:

Wire to be used	Requirements N min.
AWG #22	44.1
AWG #20	63.7
AWG #18	78.4

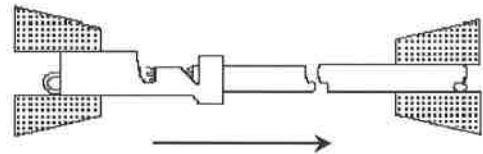

Test method: Pulling load shall be applied to a correctly crimped contact and a wire. The load required to pull the wire out of the contact or break the wire shall be measured. (Testing speed: 25 mm/min.)

Test result:

UNIT: N

Wire size	Ave.	Max.	Min.
AWG #22	90.5	98.0	82.3
AWG #20	139	143	136
AWG #18	194	200	188

n=20

### 7.2.3 Contact Insertion Force

Requirement: 14.7 N max.

Test method: The load required to insert a crimped contact into a housing shall be measured. (Testing speed: 1 to 5 mm/sec.)

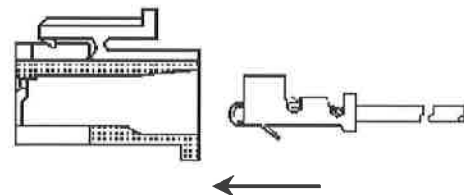

Test result:

UNIT: N

Ave.	Max.	Min.
6.0	6.9	4.9

n=20

This is our exclusive property. It is not to be copied, reprinted or disclosed to a third party, not used for manufacturing, without our written consent, and has to be returned to us.

Title Subject: VH Connector (Phosphor bronze) Lead-free product	No. T-1-2189 (R-1-2189)	Revised: B
--	----------------------------	------------

**7.2.4 Contact Retention Force**

Requirement: 29.4 N min.

Test method: A crimped contact shall be inserted into a housing and pulled in the axial direction. The load required to pull the contact out of the housing shall be measured. (Testing speed: 1 to 5 mm/sec.)

Test result:

UNIT: N		
Ave.	Max.	Min.
71.1	94.1	54.9

n=20

**7.2.5 Post Retention Force**

Requirement: 29.4 N min.

Test method: The end of a post shall be pushed perpendicularly. The load required to make the post start moving from the wafer shall be measured. (Testing speed: 25 mm/min.)

Test result:

UNIT: N		
Ave.	Max.	Min.
86.23	97.2	74.8

n=20

**7.2.6 Housing Lock Strength**

Requirement: 2-circuit; 14.7 N min.  
3-circuit or more; 49.0 N min.

Test method: Pulling load shall be applied to a housing in the direction that the housing separates from a header. The load required to separate the housing from the header shall be measured. (Testing speed: 1 to 5 mm/sec.)

Test result:

UNIT: N			
No. of circuits	Ave.	Max.	Min.
2	25.3	26.5	24.5
3 to 10	93.8	100	87.2

n=20

This is our exclusive property. It is not to be copied, reprinted or disclosed to a third party, not used for manufacturing, without our written consent, and has to be returned to us.

Title Subject: VH Connector (Phosphor bronze) Lead-free product	No. T-1-2189 (R-1-2189)	Revised: B
--	----------------------------	------------

7.3 Electrical Performance Test

7.3.1 Contact Resistance

Requirement: Initial; 10 mΩ max.  
After tests; 20 mΩ max.

Test method: Contact resistance between points A and B of a specimen assembled for actual use as shown in the figure on the right side shall be measured under the following conditions.

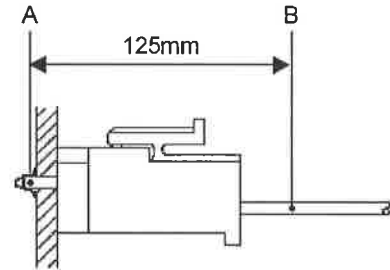

Test current: 10 mA (DC)  
Open voltage: 20 mV max.  
Wire to be used: AWG #20

Test result: See each environmental test item.

7.3.2 Current Continuity

Requirement: There shall be no current discontinuity longer than 1 microsecond during a vibration test.

Test method: Each circuit of a specimen assembled for actual use shall be connected in series and test current of 10 mA (DC) shall be applied. Current discontinuity longer than 1 microsecond during the test shall be detected by continuity meter.

Test result: See vibration test item.

7.3.3 Insulation Resistance

Requirement: Initial; 1,000 MΩ min.  
After tests; 500 MΩ min. (Humidity & thermal shock tests)

Test method: 500 VDC shall be applied between the outer surface of a housing and a contact and also between adjacent contacts of a mated specimen to measure insulation resistance. (The connector shall not be soldered.)

(Note) Between the outer surface of a housing and a contact: VHR-\*M only  
Between adjacent contacts: VHR-\*N, VHR-\*M

Test result:

UNIT: MΩ		
Items	Housing-Contact	Contact-Contact
Initial	1,000 min.	1,000 min.
After humidity test	500 min.	500 min.
After thermal shock test	500 min.	500 min.

n=10

This is our exclusive property. It is not to be copied, reprinted or disclosed to a third party, not used for manufacturing, without our written consent, and has to be returned to us.

Title Subject: VH Connector (Phosphor bronze) Lead-free product	No. T-1-2189 (R-1-2189)	Revised: B
--	----------------------------	------------

**7.3.4 Dielectric Withstanding Voltage**

Requirement: There shall be no breakdown or flashover.

Test method: Testing voltage specified below shall be applied between the outer surface of a housing and a contact and also between adjacent contacts of a mated specimen for one minute. (The header shall not be soldered.)

Initial: 1,500 VAC  
 After tests: 1,000 VAC (Humidity & thermal shock tests)

(Note) Between the outer surface of a housing and a contact: VHR-\*M only  
 Between adjacent contacts: VHR-\*N VHR-\*M

Test result:

Items	Housing-Contact	Contact-Contact
Initial	Good.	Good.
After humidity test	Good.	Good.
After thermal shock test	Good.	Good.

n=10

**7.4 Environmental Test**

**7.4.1 Durability**

Requirement: Contact resistance shall be 20 mΩ max. after the test.

Test method: A housing with crimped contacts and a header shall be mated and unmated. After repeated 50 cycles, contact resistance shall be measured.

Test result:

UNIT: mΩ

Test item	Initial			After the test		
	Ave.	Max.	Min.	Ave.	Max.	Min.
Contact resistance	5.16	5.2	5.1	5.39	5.8	5.2

n=20



Title Subject: VH Connector (Phosphor bronze) Lead-free product	No. T-1-2189 (R-1-2189)	Revised: B
--	----------------------------	------------

#### 7.4.2 Humidity

Requirement: Contact resistance shall be 20 mΩ max. after the test.  
 Insulation resistance shall be 500 MΩ min. after the test.  
 There shall be no breakdown or flashover on the dielectric withstanding voltage test.

Test method: The specimen shall be placed in a humidity chamber of the following conditions. After the test, contact resistance, insulation resistance and dielectric withstanding voltage shall be measured.

Temperature: 40 ± 2 °C  
 Relative humidity: 90 to 95 %  
 Period: 240 hours

Test result:

UNIT: mΩ

Test item	Initial			After the test		
	Ave.	Max.	Min.	Ave.	Max.	Min.
Contact resistance	5.20	5.4	5.1	5.28	5.5	5.1

n=20

#### 7.4.3 Heat Aging

Requirement: Contact resistance shall be 20 mΩ max. after the test.

Test method: The specimen shall be placed in a heat oven of the following conditions. After the test, contact resistance shall be measured.

Temperature: 85 ± 2 °C  
 Period: 250 hours

Test result:

UNIT: mΩ

Test item	Initial			After the test		
	Ave.	Max.	Min.	Ave.	Max.	Min.
Contact resistance	5.14	5.2	5.1	5.20	5.3	5.1

n=20

This is our exclusive property. It is not to be copied, reprinted or disclosed to a third party, not used for manufacturing, without our written consent, and has to be returned to us.

Title Subject: VH Connector (Phosphor bronze) Lead-free product	No. T-1-2189 (R-1-2189)	Revised: B
--	----------------------------	------------

**7.4.4 Thermal Shock**

**Requirement:** Contact resistance shall be 20 mΩ max. after the test.  
 Insulation resistance shall be 500 MΩ min. after the test.  
 There shall be no breakdown or flashover on the dielectric withstanding voltage test.

**Test method:** The specimen shall be subjected to a thermal shock test of the following conditions. After the test, contact resistance, insulation resistance and dielectric withstanding voltage shall be measured.

1 cycle consists of:  
     -55 ± 3 °C for 30 minutes  
     +85 ± 2 °C for 30 minutes  
 Total cycles: 25 cycles

Test result:

UNIT: mΩ

Test item	Initial			After the test		
	Ave.	Max.	Min.	Ave.	Max.	Min.
Contact resistance	5.15	5.2	5.1	5.16	5.2	5.1

n=20

**7.4.5 Hydrogen Sulfide Gas**

**Requirement:** Contact resistance shall be 20 mΩ max. after the test.

**Test method:** The specimen shall be subjected to hydrogen sulfide gas of the following conditions. After the test, contact resistance shall be measured.

Concentration: 3 ± 1 ppm  
 Temperature: 40 ± 2 °C  
 Relative humidity: 80 ± 5 %  
 Period: 96 hours

Test result:

UNIT: mΩ

Test item	Initial			After the test		
	Ave.	Max.	Min.	Ave.	Max.	Min.
Contact resistance	5.14	5.2	5.1	5.24	5.4	5.2

n=20

This is our exclusive property. It is not to be copied, reprinted or disclosed to a third party, not used for manufacturing, without our written consent, and has to be returned to us.

Title Subject: VH Connector (Phosphor bronze) Lead-free product	No. T-1-2189 (R-1-2189)	Revised: B
--	----------------------------	------------

**7.4.6 Salt Spray**

Requirement: Contact resistance shall be 20 mΩ max. after the test.

Test method: The specimen shall be subjected to a salt spray test of the following conditions. After the test, it shall be washed with running water and dried naturally before the measurement of contact resistance.

Temperature: 35 ± 2 °C  
 Concentration: 5% in weight  
 Period: 48 hours

Test result:

UNIT: mΩ

Test item	Initial			After the test		
	Ave.	Max.	Min.	Ave.	Max.	Min.
Contact resistance	5.17	5.3	5.1	5.21	5.4	5.1

n=20

**7.4.7 Vibration**

Requirement: Contact resistance shall be 20 mΩ max. after the test.  
 There shall be no current discontinuity longer than 1 microsecond during the test.

Test method: The specimen shall be mounted on a PCB and subjected to a vibration test of the following conditions. During the test, current continuity shall be checked. After the test, contact resistance shall be measured.

Frequency: 10-55-10 Hz/minute  
 Amplitude: 1.52 mm  
 Direction: Each of X, Y and Z-axis directions  
 \*Each axis shall be at right angles to others.  
 Period: 2 hours for each direction

Test result:

UNIT: mΩ

Test item	Initial			After the test		
	Ave.	Max.	Min.	Ave.	Max.	Min.
Contact resistance	5.23	5.4	5.0	5.37	5.5	5.1

Current continuity	There was no current discontinuity longer than 1 microsecond.
--------------------	---

n=20

This is our exclusive property. It is not to be copied, reprinted or disclosed to a third party, not used for manufacturing, without our written consent, and has to be returned to us.

Title Subject: VH Connector (Phosphor bronze) Lead-free product	No. T-1-2189 (R-1-2189)	Revised: B
--	----------------------------	------------

7.4.8 Ammonia Gas

Requirement: There shall be no stress corrosion cracking.

Test method: A mated specimen shall be subjected to an ammonia gas test of the following conditions. (The connector shall not be soldered.)  
After the test, stress corrosion cracking shall be checked.

Ammonia solution: 3% in weight  
Solution volume: 25 ml per liter of volume  
Period: 7 hours

Test result:

---

There was no stress corrosion cracking.

---

n=20

7.5 Solder Test (Header)

7.5.1 Solderability

Requirement: Plating surface of solder-dipping section of a specimen shall be covered with smooth solder.

Test method: Fluxed soldering section of a specimen shall be dipped in solder of the following conditions.

Solder: Sn-3Ag-0.5Cu  
Flux: Activation flux  
(CF-110VH-2A made by Tamura Kaken Corporation)  
Solder temperature: 245 ± 3 °C  
Immersion period: 3 ± 0.5 seconds

Test result:

---

Good.

---

n=20

Title Subject: VH Connector (Phosphor bronze) Lead-free product	No. T-1-2189 (R-1-2189)	Revised: B
--	----------------------------	------------

### 7.5.2 Resistance to Soldering Heat

Requirement: There shall be no deformation or damage which may affect the performance.

Test method: The specimen shall be mounted on a PCB and subjected to a resistance to soldering heat test of the following conditions.

Solder:	Sn-3Ag-0.5Cu
Flux:	Activation flux (CF-110VH-2A made by Tamura Kaken Corporation)
PCB to be used:	Material; Paper based epoxy resin, Pattern on one side
Solder temperature:	260 ± 5 °C
Immersion period:	5 ± 0.5 seconds

Test result:

---

There was no deformation or damage which may affect the performance.

---

n=20

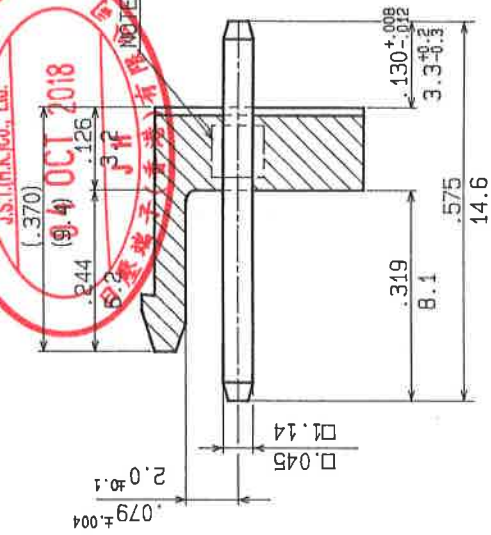

A-A SEC.

Note.

1. Unless otherwise specified tolerances  $\pm 0.12/0.3$ .
2. The deviation at the top of post shall be  $\pm 0.06/0.15$ .
3. Hatching post with holding construction.
4. No. 2, No. 4, No. 5 posts shall not be inserted.
5. Dimensions are in INCH/MM.

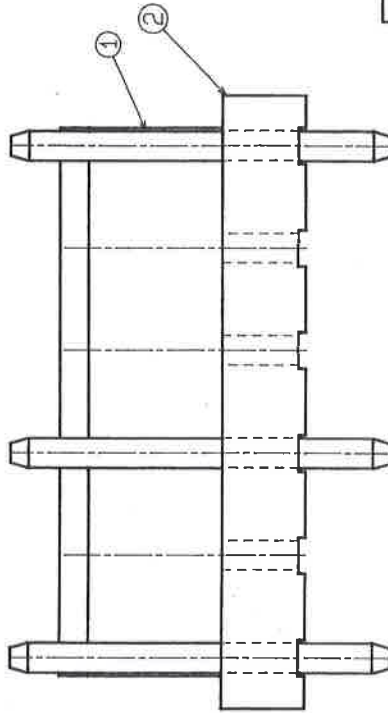
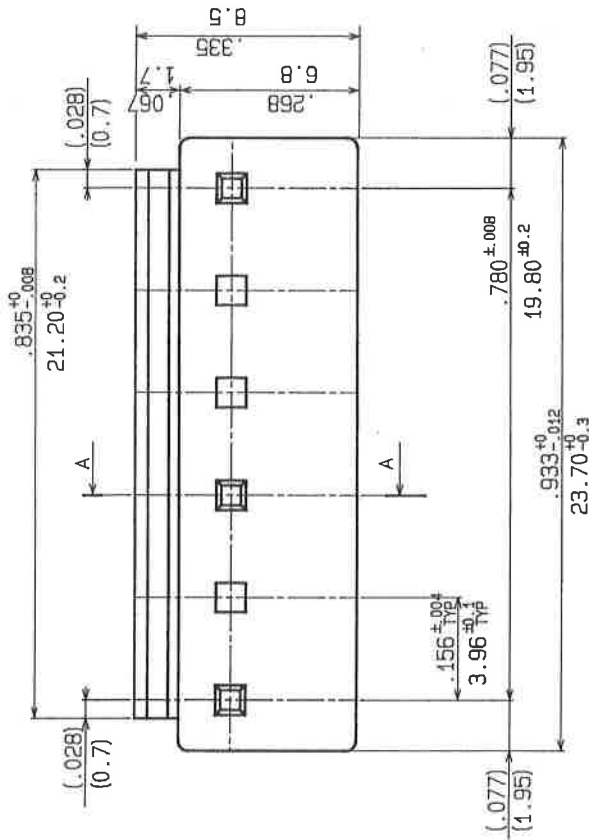

P.C Board hole layout

REVISIONS		PART NAME		PART No.		DRAWING No.	
2	Base housing Nylon66	UL94V-0	Copper-untreated Tin-plated		B3P(6-2, 4, 5)-VH-3.3		ISSUE
1	Post	Brass	TIN-plated		KRD-13387		
No.	NAME	MATERIAL	REMARKS	DATE	PROJECTION	SCALE	DATE
APPROVED BY	CHECKED BY	DRAWN BY	J. S. T.		SCALE	PROJECTION	DATE
NH					3rd		JAN 8 '91

## X-ON Electronics

Largest Supplier of Electrical and Electronic Components

*Click to view similar products for [Headers & Wire Housings](#) category:*

*Click to view products by [JST](#) manufacturer:*

Other Similar products are found below :

[95000-104TRLF](#) [10135584-644402LF](#) [DF62W-EP2022PCA](#) [95000-106TRLF](#) [DF62W-2022SCA](#) [DF62W-EP2022PC](#) [2203348](#) [DF62W-2022SC](#) [1084018](#) [1029039](#) [1084017](#) [802-10-012-10-002000](#) [1112640](#) [1112639](#) [000-34000](#) [0009482033](#) [0009507031](#) [57102-S06-03LF](#) [57202-S52-04LF](#) [PCN6-15S-2.5E](#) [0039019024](#) [58102-G61-06LF](#) [582553-1](#) [0009508121](#) [0022285053](#) [0050291907](#) [018731A](#) [LY20-4P-DT1-P1E-BR](#) [02.125.8002.8](#) [60101931](#) [60598-1 \(Cut Strip\)](#) [M1625-3R/100](#) [61062-3](#) [61082-181009](#) [636-1427](#) [638009-1](#) [641938-9](#) [641991-4](#) [644168-1](#) [647662-1](#) [65039-019ELF](#) [65817-002LF](#) [65817-015LF](#) [65863-015LF](#) [66207-023LF](#) [67016-026LF](#) [67046-001LF](#) [67095-007LF](#) [67230-005LF](#) [68002-116](#)