

Ferrite Material: A5-K5B RMS-303

RFS	Fig.	A	B	C	D	E	IMPEDANCE		STANDARD PACK (PIECES)
							25MHz	100MHz	
RFS3-2-9-K5B	3	5	3	9	3	1	46	74	1000
RFS3-3-9-K5B	3	5.5	3	9	4	1.4	32	57	1000
RFS2-3-9-K5B	3	6.5	3.8	9	4	1.4	41	72	500
RFS3-4-9-A5	3	7.5	5.3	9	5	2.8	32	59	500
RFS3-4-12-A5	3	7.5	5.3	12	5	2.8	42	86	500
RFS2-5-8-A5	3	9.1	5.6	7.8	7.2	3.7	19	41	500
RFS3-5-12-A5	3	9.5	3	12	7.6	0.8	38	79	500
RFS3-6-3-A5	3	10	3.2	3	8	1	13	42	1000
RFS3-6-7-A5	3	10	3.2	7	8	1	25	65	1000
RFS1-6-8-A5	3	10	3.2	8	8	1	28	60	1000
RFS5-7-2-A5	5	13.84	3.94	1.88	9.78	1.52	10	32	2000
RFS2-8-12-A5	2	14.7	2.75	12	11	0.7	28	63	192
RFS2-9-5-A5	2	16	3	5	11.5	0.5	14	40	375
RFS2-9-8-3-A5	2	16	3	8	11.5	0.5	24	68	200
RFS2-9-4-A5	2	16	4	4	11.5	0.5	15	40	450
RFS2-9-6-A5	2	16	5	6	11.5	0.5	20	48	352
RFS2-9-8-A5	2	16	5	8	11.5	0.5	29	72	288
RFS2-9-12-A5	2	16	5	12	11.5	0.5	41	73	160
RFS2-9-12-2-A5	2	16	5	12	11.5	1.2	37	69	160
RFS2-9-15-A5	2	16	5	15	11.5	0.5	50	90	144
RFS2-9-20-A5	2	16	5	20	11.5	0.5	60	120	126
RFS2-11-10-A5	2	18	5	8	14	1	45	164	252
RFS2-11-20-A5	2	18.9	6.5	20	14	1.8	61	123	84
RFS2-11-12-A5	2	19	6.5	12	14	1.8	38	62	144
RFS2-13-15-A5	2	20.5	3.5	15	16.5	0.8	36	97	126
RFS1-15-7-2-A5	1	23.3	2.5	7	20	0.9	14	41	240
RFS1-15-7-A5	1	23.3	3	7	20	0.9	17	45	240
RFS1-15-10-A5	1	23.3	3	10	20	0.9	18	47	168
RFS1-15-12-A5	1	23.3	3	12	20	0.9	23	58	144
RFS1-15-15-A5	1	23.3	3	15	20	0.9	24	59	108
RFS1-14-15-A5	1	23.8	3.2	15	18.7	1.1	27	77	120
RFS2-14-7-A5	2	23.8	6.3	7	18.7	1.1	21	47	240

Standard Pack sizes may vary

NOTES.

- 1) See drawing 05-133 sheet 4 onwards for Impedance graphs.
- 2) Impedance figures are typical values.
- 3) other sizes available by special order.
- 4) Packaging information is only a guide & subject to variation.

REV.	MODIFICATION.	DATE	DRN
02	CO-2010429	06/10/08	SF
03	CO-2010456	28/10/08	OW
04	CO-2010481	18/11/08	SF
05	CO-2010520	18/12/08	SF
06	CO-2010933	03/06/10	SF
07	CO-2011052	03/02/11	SF

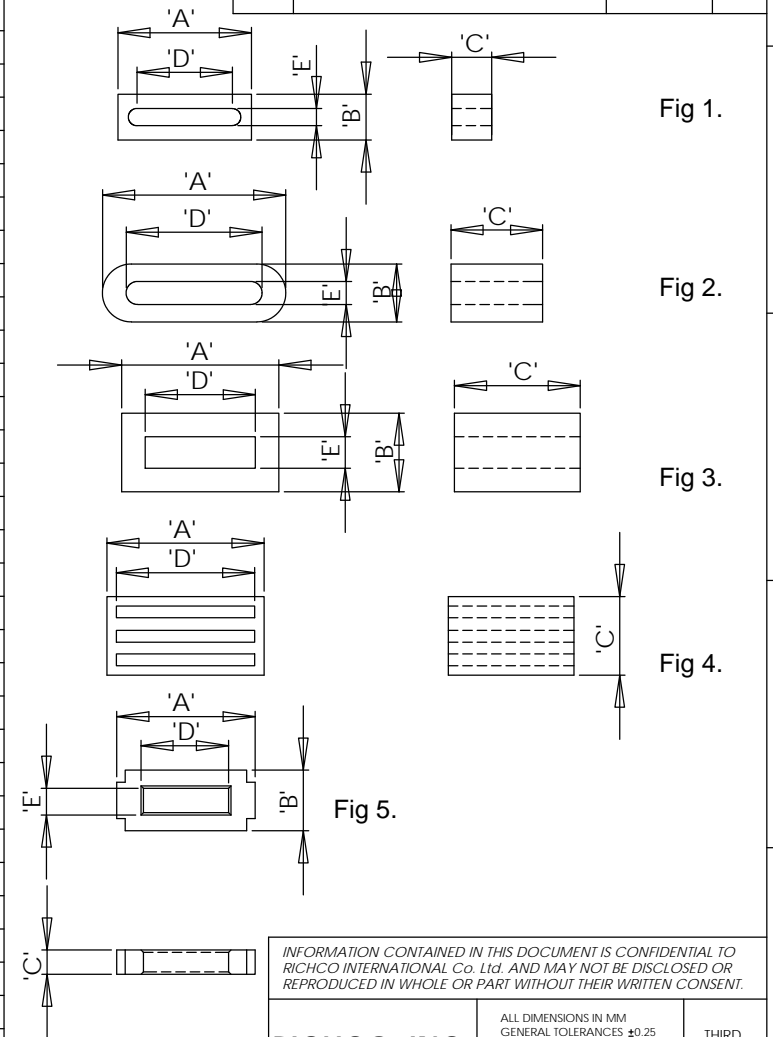

INFORMATION CONTAINED IN THIS DOCUMENT IS CONFIDENTIAL TO RICHCO INTERNATIONAL Co. Ltd. AND MAY NOT BE DISCLOSED OR REPRODUCED IN WHOLE OR PART WITHOUT THEIR WRITTEN CONSENT.

<b>RICHCO, INC.</b> WWW.RICHCO-INC.COM	ALL DIMENSIONS IN MM GENERAL TOLERANCES ±0.25 UNLESS OTHERWISE STATED 1 DECIMAL PLACE ± 2 DECIMAL PLACES ± ANGULAR ±1°	THIRD ANGLE 

MATERIAL: <b>See Table</b>		COLOUR: <b>See Table</b>	
DESCRIPTION: <b>RFS Flat Cable Sleeve Cores</b>		PART No: <b>See Table</b>	
DRG No: <b>05-133</b>	NPR No:	Mass:(g)	SHEET SIZE <b>A3</b>
DRN <b>NJB</b>	DATE <b>02/12/05</b>	CHKD <b>RC</b>	DATE <b>02/12/05</b>
SCALE <b>NTS</b>		SHEET No. <b>1 of 8</b>	

Ferrite Material: A5-K5B RMS-303

RFS	Fig.	A	B	C	D	E	IMPEDANCE		STANDARD PACK (PIECES)
							25MHz	100MHz	
RFS2-14-13-A5	2	23.8	6.3	12.5	18.7	1.1	46	96	120
RFS2-2-30-A5	2	24	12	30	15	4	120	191	48
RFS2-15-12-A5	2	24.5	5	12	20	0.5	35	70	144
RFS2-15-20-A5	2	24.5	5	20	20	0.5	41	78	84
RFS2-17-20-A5	2	25	3.7	20	22	0.7	43	114	56
RFS2-16-12-A5	2	25.5	3	12	21.5	0.65	27	87	132
RFS1-16-15-A5	1	25.5	4.5	15	21.5	0.65	39	110	144
RFS1-17-15-A5	1	25.5	5	15	21.5	0.65	48	128	108
RFS2-18-8-A5	2	28.5	6.5	8	23.5	0.8	28	65	170
RFS2-18-15-A5	2	28.5	6.5	15	23.5	1	44	91	90
RFS2-18-18-A5	2	28.5	6.5	18	23.5	1	55	127	80
RFS2-18-10-A5	2	28.6	7.7	10	23.5	1.7	31	71	140
RFS2-22-8-A5	2	31	3	8	27	1	13	42	160
RFS2-22-12-A5	2	31	3	12	27	1	19	56	110
RFS2-22-20-A5	2	31	4	20	27	0.7	42	121	60
RFS2-22-9-A5	2	31	5	9	27	1	29	88	150
RFS2-20-12-A5	2	31	5	12	27	1	28	75	110
RFS2-21-18-A5	2	31	5	18	27	1	34	94	70
RFS2-21-25-A5	2	32	4	25	27	0.7	51	142	36
RFS2-22-25-A5	2	32	6	25	28	0.85	59	146	36
RFS4-21-16-A5	4	32	11.8	16	27	1	76	188	80
RFS2-21-8-A5	2	33.5	6.5	8	27	1.3	21	53	136
RFS2-21-10-A5	2	33.5	6.5	10	27	1.3	26	57	84
RFS2-21-12-A5	2	33.5	6.5	12	27	1.3	30	66	70
RFS2-21-15-A5	2	33.5	6.5	15	27	1.3	36	78	72
RFS2-21-20-A5	2	33.5	6.5	20	27	1.3	58	149	56
RFS2-24-18-A5	2	36	6.5	18	31	0.6	52	147	64
RFS2-24-8-A5	2	36	7.5	8	31	1	29	79	48
RFS2-24-20-A5	2	36	7.5	20	31	1	54	122	32
RFS2-24-30-A5	2	36	7.5	30	31	1	72	174	32
RFS2-24-36-A5	2	36	7.5	36	31	1	92	192	24
RFS2-25-12-A5	2	36	5	12	32.4	0.8	29	88	90

Standard Pack sizes may vary

NOTES.

- 1) See drawing 05-133 sheet 4 onwards for Impedance graphs.
- 2) Impedance figures are typical values.
- 3) other sizes available by special order.
- 4) Packaging information is only a guide & subject to variation.

REV.	MODIFICATION.	DATE	DRN
02	CO-2010429	06/10/08	SF
03	CO-2010456	28/10/08	OW
04	CO-2010481	18/11/08	SF
05	CO-2010520	18/12/08	SF
06	CO-2010933	03/06/10	SF
07	CO-2011052	03/02/11	SF

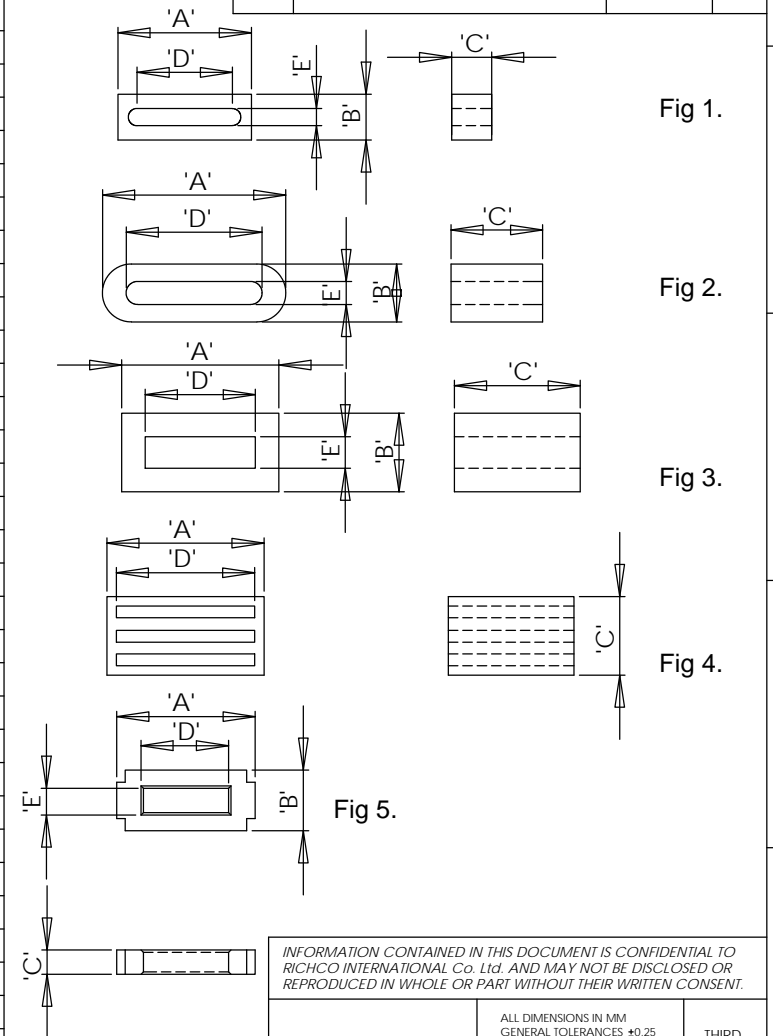

INFORMATION CONTAINED IN THIS DOCUMENT IS CONFIDENTIAL TO RICHCO INTERNATIONAL Co. Ltd. AND MAY NOT BE DISCLOSED OR REPRODUCED IN WHOLE OR PART WITHOUT THEIR WRITTEN CONSENT.

<b>RICHCO, INC.</b> WWW.RICHCO-INC.COM	ALL DIMENSIONS IN MM GENERAL TOLERANCES ±0.25 UNLESS OTHERWISE STATED 1 DECIMAL PLACE ± 2 DECIMAL PLACES ± ANGULAR ±1°	THIRD ANGLE 
---	---	-----------------

MATERIAL: <b>See Table</b>		COLOUR: <b>See Table</b>	
DESCRIPTION: <b>RFS Flat Cable Sleeve Cores</b>		PART No: <b>See Table</b>	
DRG No: <b>05-133</b>	NPR No:	Mass:(g)	SHEET SIZE <b>A3</b>
DRN <b>NJB</b>	DATE <b>02/12/05</b>	CHKD <b>RC</b>	DATE <b>02/12/05</b>
SCALE <b>NTS</b>		SHEET No. <b>2 of 8</b>	

Ferrite Material: A5-K5B RMS-303

RFS	Fig.	A	B	C	D	E	IMPEDANCE		STANDARD PACK (PIECES)
							25MHz	100MHz	
RFS2-26-12-A5	2	38.5	4	12	35	0.8	25	68	72
RFS2-26-15-A5	2	38.5	4	15	35	0.8	31	100	56
RFS1-20-25-A5	1	38.53	12.06	25.4	26.77	1.9	100	180	30
RFS2-27-6-A5	2	40	6.5	6	35	1.3	16	45	144
RFS2-27-8-A5	2	40	6.5	8	35	1.3	23	58	96
RFS2-27-10-A5	2	40	6.5	10	35	1.3	25	64	84
RFS2-27-12-A5	2	40	6.5	12	35	1.3	28	69	72
RFS2-27-12-2-A5	2	40	6.5	12	35	2	24	59	72
RFS2-27-15-A5	2	40	6.5	15	35	1.3	32	85	54
RFS2-27-18-A5	2	40	6.5	18	35	1.3	36	98	48
RFS2-27-20-A5	2	40	6.5	20	35	1.3	41	105	42
RFS3-4-5-A5	3	40	11.4	5	32	7.4	12	36	96
RFS1-27-18-A5	1	41	12.5	18	34.4	1.5	60	136	24
RFS3-27-18-A5	3	45	12.7	18	35	1.8	51	114	42
RFS3-27-10-A5	3	45	12.7	10	35	1.8	39	89	48
RFS1-27-28-A5	1	45.1	12.5	28.5	34.4	1.5	95	195	24
RFS2-30-12-A5	2	45.2	6.5	12	40	1.3	27	70	72
RFS2-30-15-A5	2	45.2	6.5	15	40	1.3	31	70	54
RFS2-34-8-A5	2	49.6	6.5	8	44	1.3	17	50	96
RFS2-34-12-A5	2	49.6	6.5	12	44	1.3	25	66	72
RFS2-34-15-A5	2	49.6	6.5	15	44	1.3	31	94	54
RFS2-34-12-2-A5	2	49.6	7	12	44	1.8	25	66	66
RFS2-35-12-A5	2	50	6.5	12	44.9	1.4	23	62	72
RFS2-40-12-A5	2	57.6	6.5	12	52	1.3	25	75	48
RFS2-40-20-A5	2	58.6	7.5	20	52	1.3	43	119	30
RFS1-38-13-A5	1	60	12	12.7	48.5	2.2	40	95	30
RFS2-43-12-A5	2	60.6	6.5	12	55.2	1.3	28	92	48

Standard Pack sizes may vary

REV.	MODIFICATION.	DATE	DRN
02	CO-2010429	06/10/08	SF
03	CO-2010456	28/10/08	OW
04	CO-2010481	18/11/08	SF
05	CO-2010520	18/12/08	SF
06	CO-2010933	03/06/10	SF
07	CO-2011052	03/02/11	SF

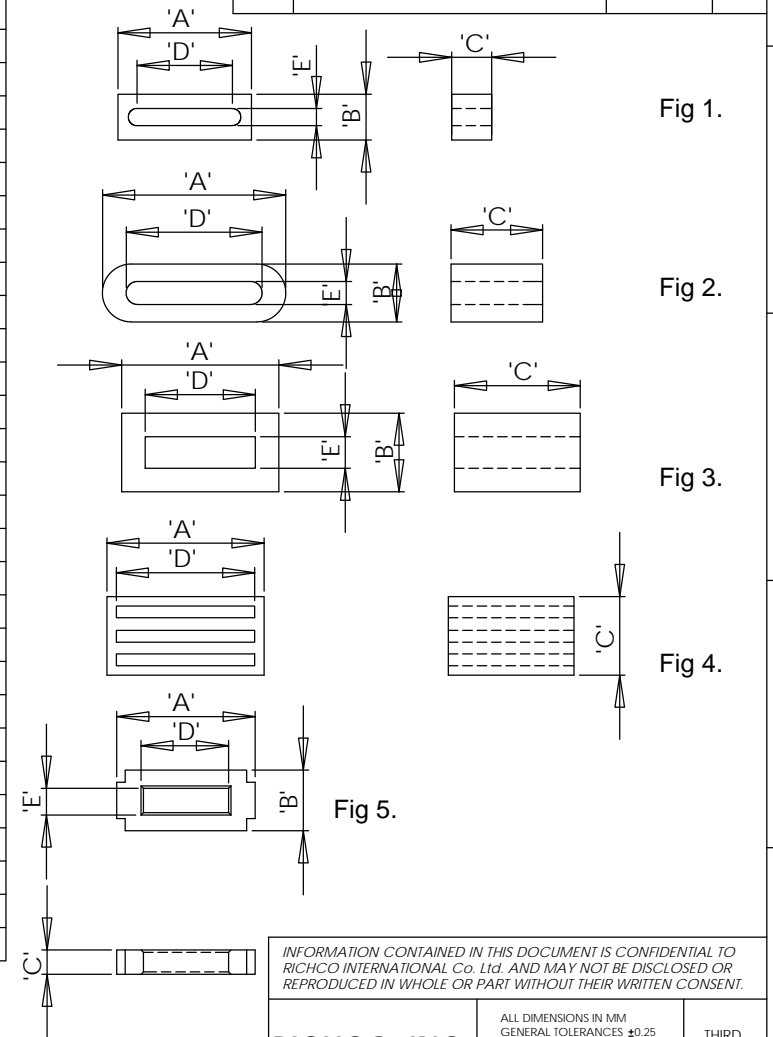

INFORMATION CONTAINED IN THIS DOCUMENT IS CONFIDENTIAL TO RICHCO INTERNATIONAL Co. Ltd. AND MAY NOT BE DISCLOSED OR REPRODUCED IN WHOLE OR PART WITHOUT THEIR WRITTEN CONSENT.

<b>RICHCO, INC.</b> WWW.RICHCO-INC.COM	ALL DIMENSIONS IN MM GENERAL TOLERANCES ±0.25 UNLESS OTHERWISE STATED 1 DECIMAL PLACE ± 2 DECIMAL PLACES ± ANGULAR ±1°	THIRD ANGLE 
	MATERIAL: See Table      COLOUR: See Table	

DESCRIPTION: <b>RFS Flat Cable Sleeve Cores</b>		PART No: See Table	
DRG No: <b>05-133</b>	NPR No:	Mass:(g)	SHEET SIZE <b>A3</b>
DRN <b>NJB</b>	DATE <b>02/12/05</b>	CHKD <b>RC</b>	DATE <b>02/12/05</b>
SCALE <b>NTS</b>		SHEET No. <b>3 of 8</b>	

- NOTES.
- 1) See drawing 05-133 sheet 4 onwards for Impedance graphs.
  - 2) Impedance figures are typical values.
  - 3) other sizes available by special order.
  - 4) Packaging information is only a guide & subject to variation.

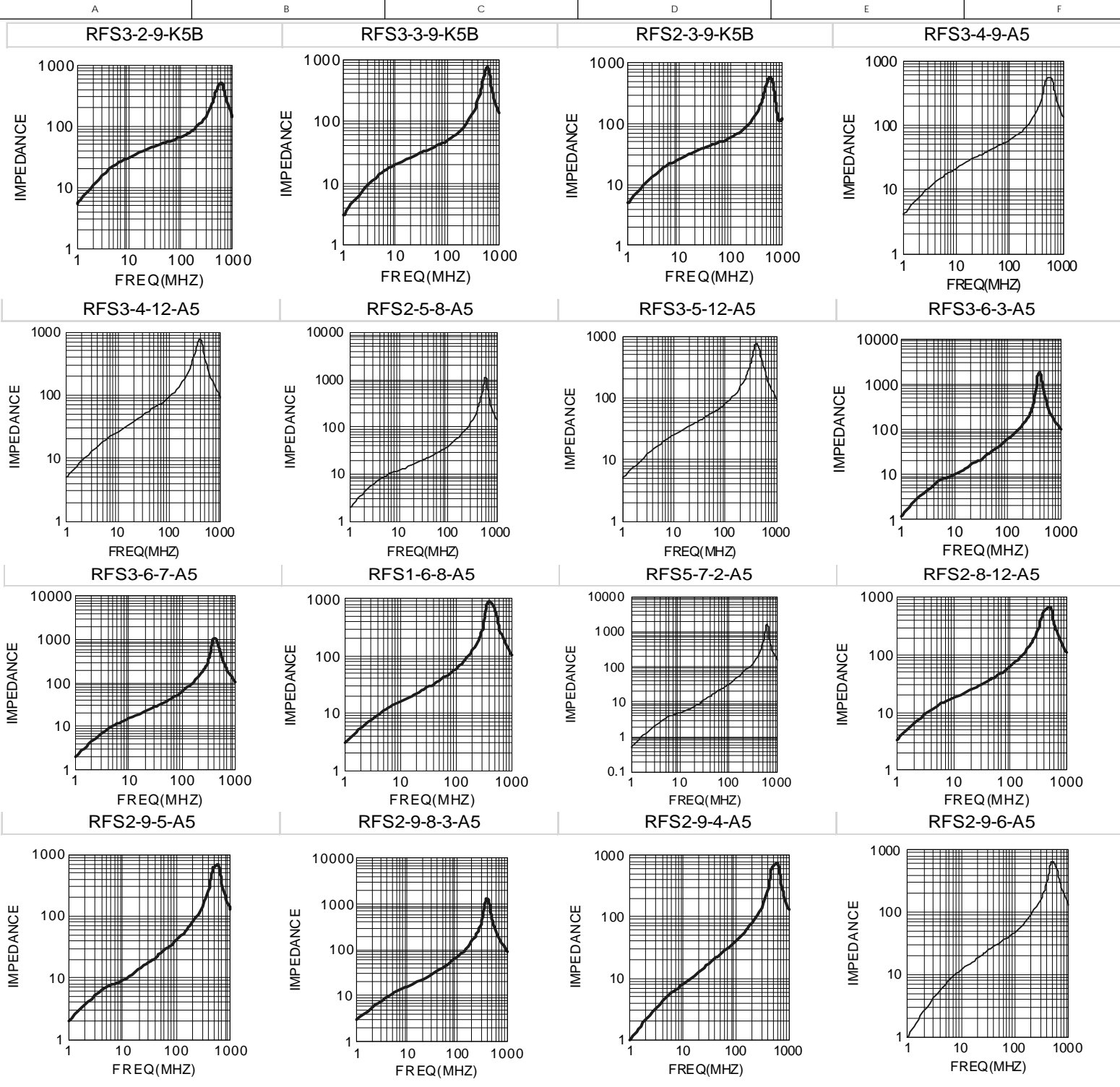

REV.	MODIFICATION.	DATE	DRN
02	CO-2010429	06/10/08	SF
03	CO-2010456	28/10/08	OW
04	CO-2010481	18/11/08	SF
05	CO-2010520	18/12/08	SF
06	CO-2010933	03/06/10	SF
07	CO-2011052	03/02/11	SF

NOTES.  
1) Impedance figures are typical values.

INFORMATION CONTAINED IN THIS DOCUMENT IS CONFIDENTIAL TO RICHCO INTERNATIONAL Co. Ltd. AND MAY NOT BE DISCLOSED OR REPRODUCED IN WHOLE OR PART WITHOUT THEIR WRITTEN CONSENT.

<b>RICHCO, INC.</b> WWW.RICHCO-INC.COM		ALL DIMENSIONS IN MM GENERAL TOLERANCES ±0.25 UNLESS OTHERWISE STATED 1 DECIMAL PLACE ± 2 DECIMAL PLACES ± ANGULAR ±1°		THIRD ANGLE 	
MATERIAL: <b>See Table</b>			COLOUR: <b>See Table</b>		
DESCRIPTION: <b>RFS Flat Cable Sleeve Cores</b>			PART No: <b>See Table</b>		
DRG No: <b>05-133</b>		NPR No:		Mass:(g) SHEET SIZE <b>A3</b>	
DRN <b>NJB</b>	DATE <b>02/12/05</b>	CHKD <b>RC</b>	DATE <b>02/12/05</b>	SCALE <b>NTS</b>	SHEET No. <b>4 of 8</b>

REV.	MODIFICATION.	DATE	DRN
02	CO-2010429	06/10/08	SF
03	CO-2010456	28/10/08	OW
04	CO-2010481	18/11/08	SF
05	CO-2010520	18/12/08	SF
06	CO-2010933	03/06/10	SF
07	CO-2011052	03/02/11	SF

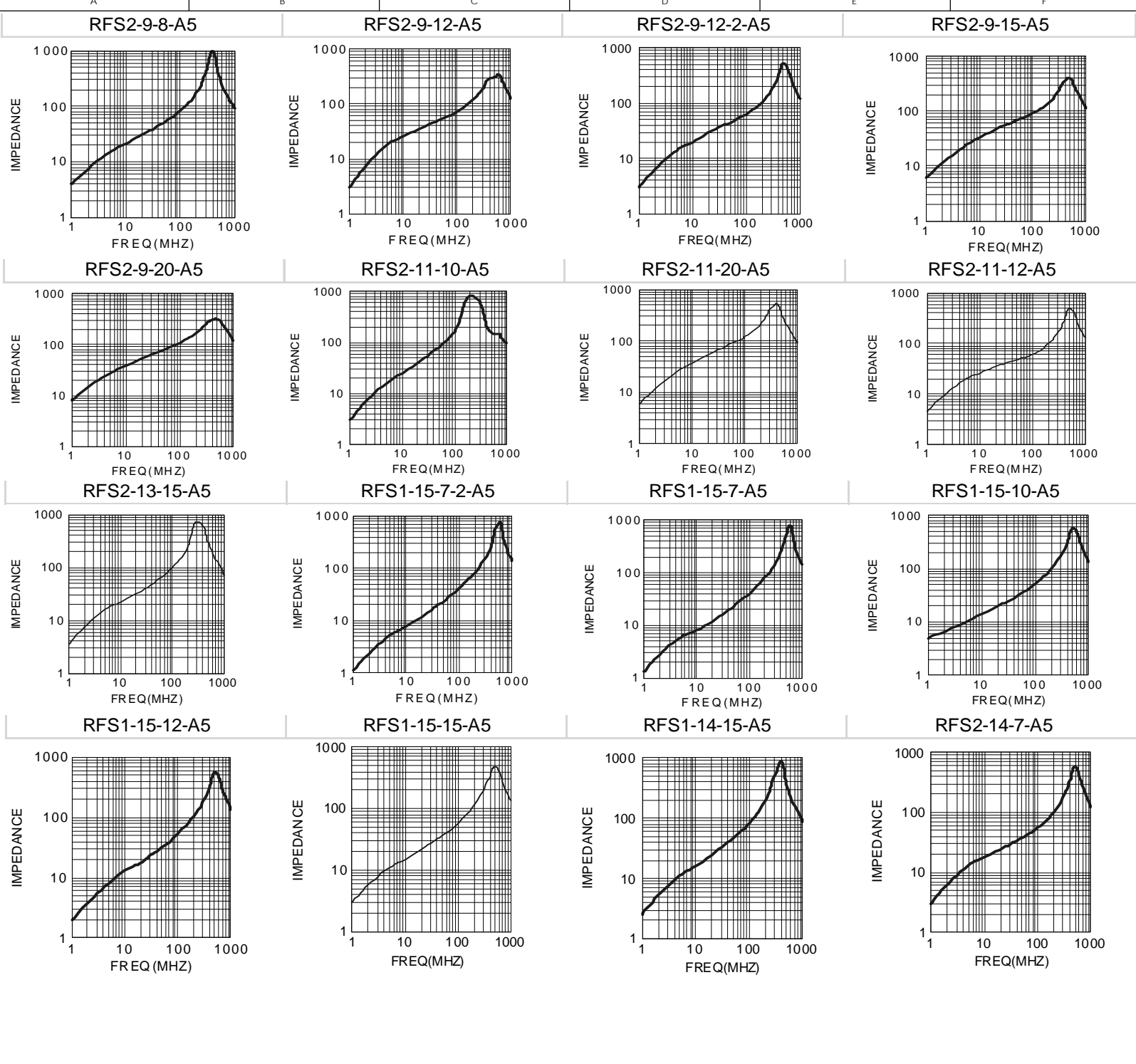

NOTES.  
1) Impedance figures are typical values.

INFORMATION CONTAINED IN THIS DOCUMENT IS CONFIDENTIAL TO RICHCO INTERNATIONAL Co. Ltd. AND MAY NOT BE DISCLOSED OR REPRODUCED IN WHOLE OR PART WITHOUT THEIR WRITTEN CONSENT.

**RICHCO, INC.**  
WWW.RICHCO-INC.COM

ALL DIMENSIONS IN MM  
GENERAL TOLERANCES ±0.25  
UNLESS OTHERWISE STATED  
1 DECIMAL PLACE ±  
2 DECIMAL PLACES ±  
ANGULAR ±1°

THIRD ANGLE

MATERIAL: <b>See Table</b>		COLOUR: <b>See Table</b>	
DESCRIPTION: <b>RFS Flat Cable Sleeve Cores</b>		PART No: <b>See Table</b>	
DRG No: <b>05-133</b>	NPR No:	Mass:(g)	SHEET SIZE <b>A3</b>
DRN <b>NJB</b>	DATE <b>02/12/05</b>	CHKD <b>RC</b>	DATE <b>02/12/05</b>
SCALE <b>NTS</b>		SHEET No. <b>5 of 8</b>	

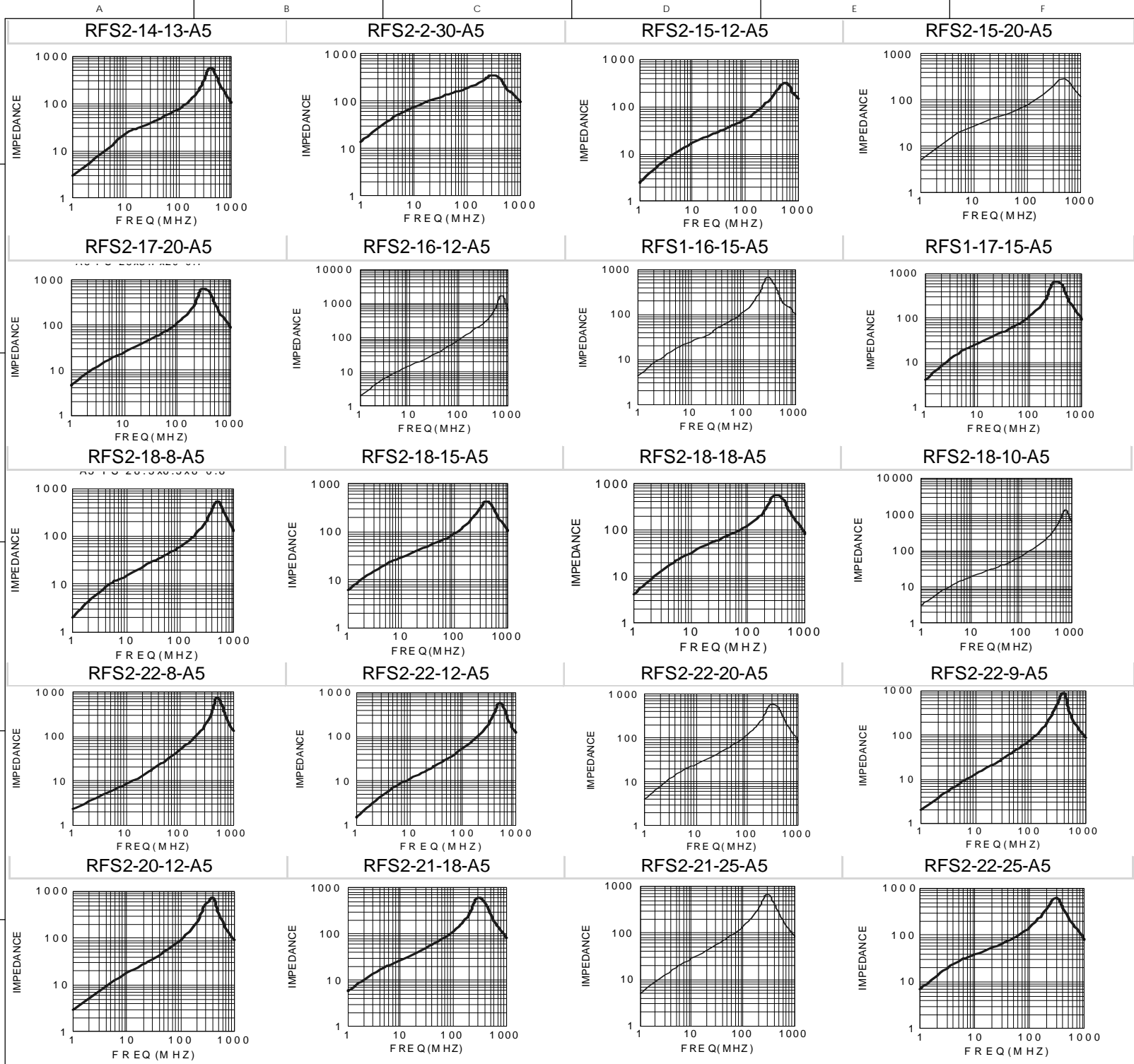

REV.	MODIFICATION.	DATE	DRN
02	CO-2010429	06/10/08	SF
03	CO-2010456	28/10/08	OW
04	CO-2010481	18/11/08	SF
05	CO-2010520	18/12/08	SF
06	CO-2010933	03/06/10	SF
07	CO-2011052	03/02/11	SF

NOTES.  
1) Impedance figures are typical values.

INFORMATION CONTAINED IN THIS DOCUMENT IS CONFIDENTIAL TO RICHCO INTERNATIONAL Co. Ltd. AND MAY NOT BE DISCLOSED OR REPRODUCED IN WHOLE OR PART WITHOUT THEIR WRITTEN CONSENT.

**RICHCO, INC.**  
WWW.RICHCO-INC.COM

ALL DIMENSIONS IN MM  
GENERAL TOLERANCES ±0.25  
UNLESS OTHERWISE STATED  
1 DECIMAL PLACE ±  
2 DECIMAL PLACES ±  
ANGULAR ±1°

MATERIAL: <b>See Table</b>		COLOUR: <b>See Table</b>	
DESCRIPTION: <b>RFS Flat Cable Sleeve Cores</b>		PART No: <b>See Table</b>	
DRG No: <b>05-133</b>	NPR No:	Mass:(g)	SHEET SIZE
DRN <b>NJB</b>	DATE <b>02/12/05</b>	CHKD <b>RC</b>	DATE <b>02/12/05</b>
SCALE <b>NTS</b>		SHEET No. <b>6 of 8</b>	

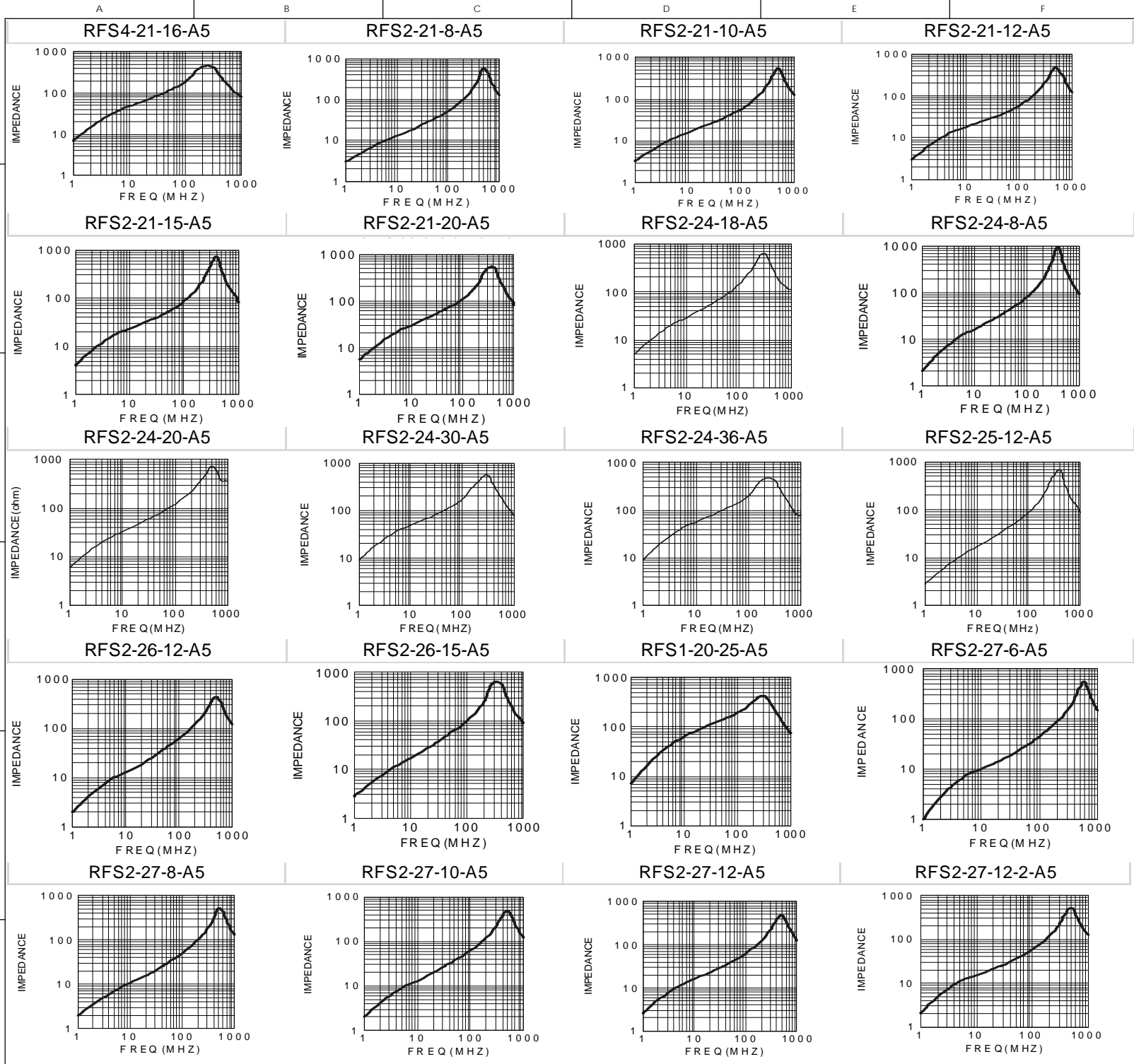

REV.	MODIFICATION.	DATE	DRN
02	CO-2010429	06/10/08	SF
03	CO-2010456	28/10/08	OW
04	CO-2010481	18/11/08	SF
05	CO-2010520	18/12/08	SF
06	CO-2010933	03/06/10	SF
07	CO-2011052	03/02/11	SF

NOTES.  
1) Impedance figures are typical values.

INFORMATION CONTAINED IN THIS DOCUMENT IS CONFIDENTIAL TO RICHCO INTERNATIONAL Co. Ltd. AND MAY NOT BE DISCLOSED OR REPRODUCED IN WHOLE OR PART WITHOUT THEIR WRITTEN CONSENT.

**RICHCO, INC.**  
WWW.RICHCO-INC.COM

ALL DIMENSIONS IN MM  
GENERAL TOLERANCES ±0.25  
UNLESS OTHERWISE STATED  
1 DECIMAL PLACE ±  
2 DECIMAL PLACES ±  
ANGULAR ±1°

MATERIAL: <b>See Table</b>		COLOUR: <b>See Table</b>	
DESCRIPTION: <b>RFS Flat Cable Sleeve Cores</b>		PART No: <b>See Table</b>	
DRG No: <b>05-133</b>	NPR No:	Mass:(g)	SHEET SIZE <b>A3</b>
DRN <b>NJB</b>	DATE <b>02/12/05</b>	CHKD <b>RC</b>	DATE <b>02/12/05</b>
SCALE <b>NTS</b>		SHEET No. <b>7 of 8</b>	

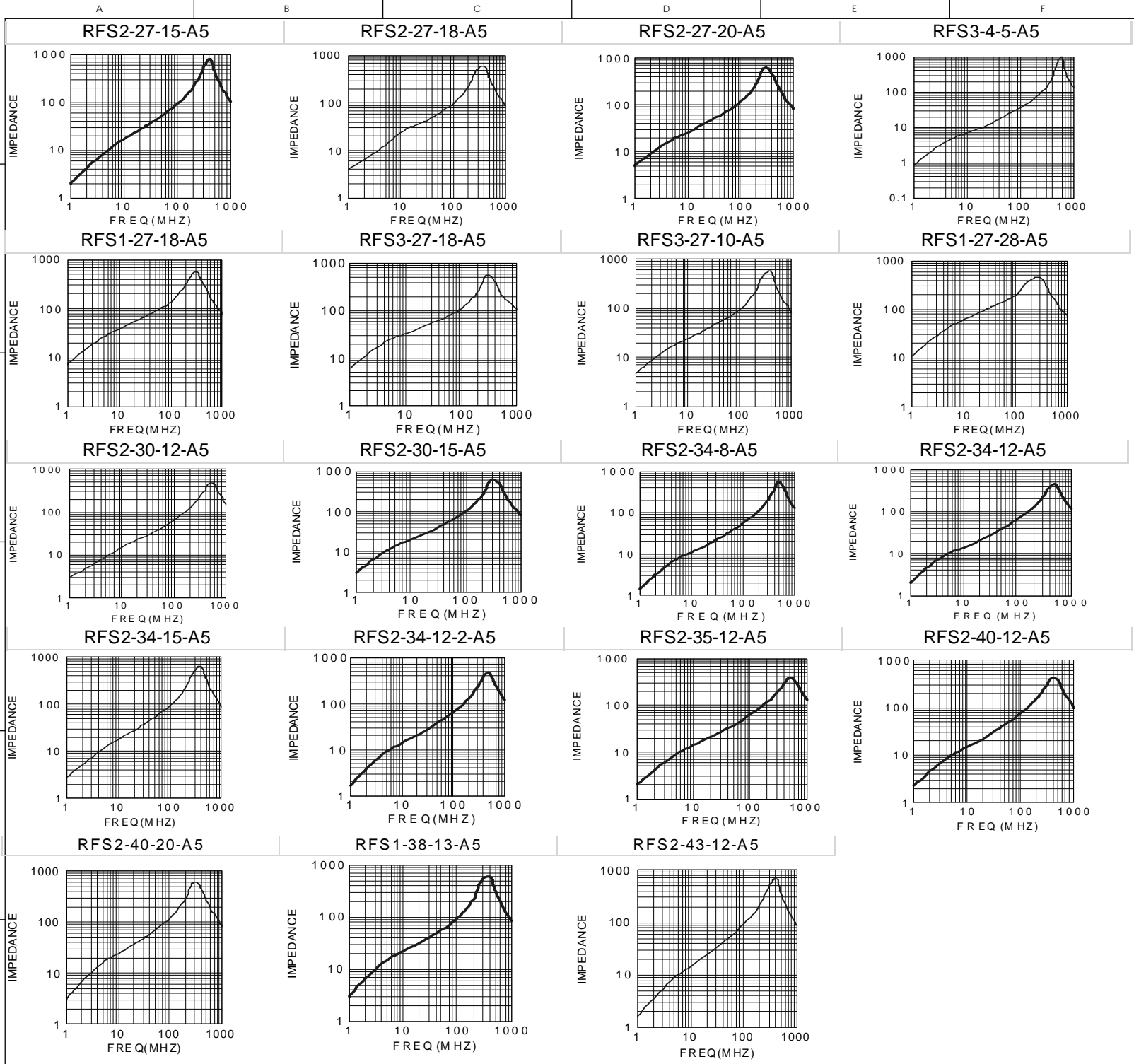

REV.	MODIFICATION.	DATE	DRN
02	CO-2010429	06/10/08	SF
03	CO-2010456	28/10/08	OW
04	CO-2010481	18/11/08	SF
05	CO-2010520	18/12/08	SF
06	CO-2010933	03/06/10	SF
07	CO-2011052	03/02/11	SF

NOTES.  
1) Impedance figures are typical values.

INFORMATION CONTAINED IN THIS DOCUMENT IS CONFIDENTIAL TO RICHCO INTERNATIONAL Co. Ltd. AND MAY NOT BE DISCLOSED OR REPRODUCED IN WHOLE OR PART WITHOUT THEIR WRITTEN CONSENT.

**RICHCO, INC.**  
WWW.RICHCO-INC.COM

ALL DIMENSIONS IN MM  
GENERAL TOLERANCES ±0.25  
UNLESS OTHERWISE STATED  
1 DECIMAL PLACE ±  
2 DECIMAL PLACES ±  
ANGULAR ±1°

THIRD ANGLE

MATERIAL: <b>See Table</b>		COLOUR: <b>See Table</b>	
DESCRIPTION: <b>RFS Flat Cable Sleeve Cores</b>		PART No: <b>See Table</b>	
DRG No: <b>05-133</b>	NPR No:	Mass:(g)	SHEET SIZE <b>A3</b>
DRN <b>NJB</b>	DATE <b>02/12/05</b>	CHKD <b>RC</b>	DATE <b>02/12/05</b>
SCALE <b>NTS</b>		SHEET No. <b>8 of 8</b>	



## X-ON Electronics

Largest Supplier of Electrical and Electronic Components

*Click to view similar products for [Ferrite Cable Cores](#) category:*

*Click to view products by [Richco](#) manufacturer:*

Other Similar products are found below :

[2643626102](#) [FX28R0984-0](#) [FX28R0984-2](#) [AB 3X2X3SM](#) [2643164251](#) [2643665709](#) [2661626402](#) [LB 2.8X4.5U](#) [28R1127](#) [28R1260](#)  
[28R1575](#) [SM28R0760](#) [SM28R1531](#) [2631006302](#) [2643165451](#) [2643178351](#) [28R0760](#) [MS 21X14X4.5 W](#) [SM28B1101](#) [SS7X4X3W](#) [4327](#)  
[030 16141](#) [ASSE017-2](#) [2643103102](#) [2643164151](#) [2943666671](#) [4327 030 12611](#) [2643163851](#) [AB4X2X6SM](#) [432703013631](#) [LB4X2X8U](#)  
[28B1101](#) [28B0785](#) [SM28R1575](#) [SM28R1260](#) [74270051](#) [2643625902](#) [74278032](#) [2643480009](#) [2673069901](#) [HFB123049-300](#) [HFB143064-](#)  
[100](#) [HFB143064-300](#) [HFB170070-000](#) [ETD29/16/10-3C94](#) [ETD29-3F3](#) [ETD39-3C94](#) [RFP1-20-10-A5](#) [RFP1-40-28-M-A5](#) [RFP2-10-10-A5](#)  
[RFP2-25-12-A5](#)