

Low Voltage Startup, 1MHz

500mA Synchronous Step-Up DC-DC

FEATURES

- Low Vin Start-up Voltage down to 850mV
Ideal for Single Alkaline Cell operations
- Capable of delivering 500mA output current at Vin=3.0V, Vout=3.3V
- 1MHz Switching Frequency allows small inductor and output cap
- Input boost-strapping allows using small or no input cap
- Low Noise PWM control
- Internally Compensated Current Mode Control
- Internal Synchronous Rectifier
- Logic Control Shutdown (IQ<1uA)
- Available in SOT23-5

DESCRIPTION

The BL8542C is a step-up converter that provides a boosted output voltage from a low voltage source. Because of its proprietary design, it starts up at a very low input voltage down to 850mV, making it an ideal choice for single cell alkaline/NiMH battery operations.

A switching frequency of 1MHz minimizes solution footprint by allowing the use of tiny, low profile inductors and ceramic capacitors. The current mode PWM design is internally compensated, reducing external parts count.

BL8542C is housed in a tiny SOT23-5 package.

APPLICATIONS

- Medical Instruments
- Bluetooth Headsets
- Flash-Based MP3 Players
- Wireless Mice
- One to Three Cell Battery Operated Devices

TYPICAL APPLICATION

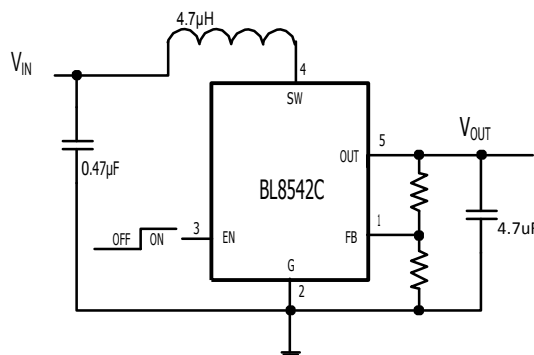

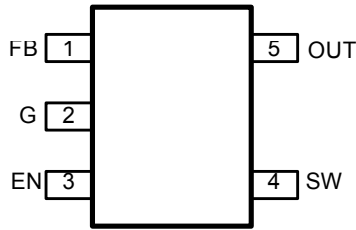
PIN CONFIGURATION

ABSOLUTE MAXIMUM RATINGS

(Note: Exceeding these limits may damage the device. Exposure to absolute maximum rating conditions for long periods may affect device reliability.)

SW Voltage	-0.3V to 5.5V
EN,FB,OUT Voltage	-0.3V to 5.5V
Junction to Ambient Thermal Resistance.....	190°C/W
Maximum Power Dissipation.....	0.45W
Operating Temperature Range	-40°C to 85°C
Storage Temperature Range	-55°C to 150°C

ELECTRICAL CHARACTERISTICS

($V_{IN} = 1.8V$, $V_{OUT} = 3.3V$, unless otherwise specified. Typical values are at $T_A = 25^\circ C$.)

PARAMETER	CONDITIONS	MIN	TYP	MAX	UNITS
Minimum Input Voltage			0.7		V
Startup Voltage			0.85	1.1	V
Output Voltage	FB=OUT	3.23	3.3	3.36	V
	FB=G	4.90	5	5.10	V
FB Feedback Voltage	$V_{OUT} = 2.5$ to $5V$		0.6		V
FB Input Current				50	nA
Output Voltage Range	External divider	2.5		5	V
Quiescent Current at OUT	$V_{FB} = 0.7V$		50		μA
Shutdown Supply Current at OUT	EN=G		0.1	1	μA
Switching Frequency			1.0		MHz
NMOS Switch On Resistance	$I_{SW} = 100mA$		0.3		Ω
PMOS Switch On Resistance	$I_{SW} = 100mA$		0.6		Ω
NMOS Switch Current Limit		1			A
SW Leakage Current	$V_{OUT} = 5.5V$, $V_{SW} = 0$ or $5.5V$, EN=G			1	μA
EN Input Current				1	μA
EN Input Low Voltage				0.3	V
EN Input High Voltage		0.6			V

PIN DESCRIPTION

PIN#	NAME	DESCRIPTION
1	FB	Output Voltage Selection and Feedback Input. Connect this pin to G for VOUT = 5V, to OUT for VOUT = 3.3V. Connect FB to a resistor divider to set the output voltage using the following equation, $V_{out} = 0.6V(1+R1/R2)$
2	G	Ground. Tie this pin directly to the local ground plane.
3	EN	Enable Pin. Tie this pin to 0.6V or higher to enable the device. Tie below 0.3V to turn off the device.
4	SW	Switch Pin. Connect an inductor between this pin and Vin. Minimize the metal trace area connected to this pin to minimize EMI.
5	OUT	Output Pin. OUT also provides power to the IC itself.

TYPICAL CHARACTERISTICS

(Typical values are at TA=25°C unless otherwise specified..)

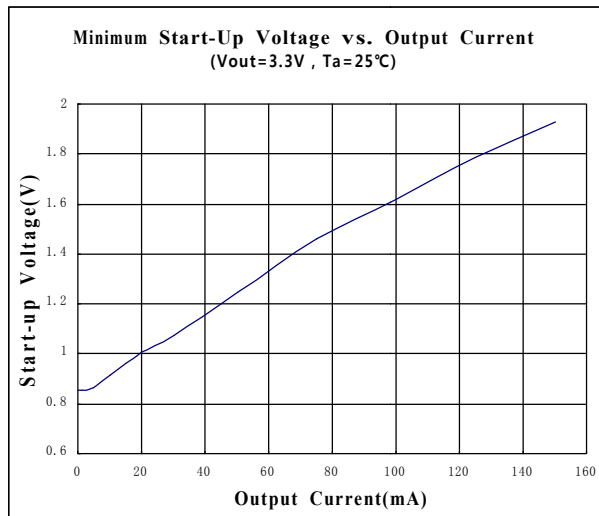
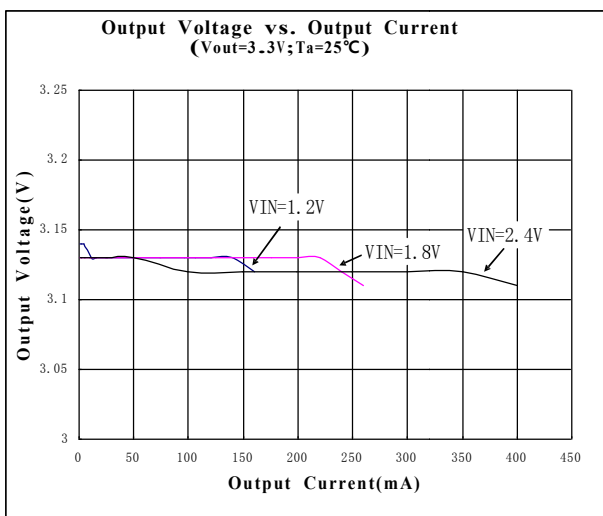
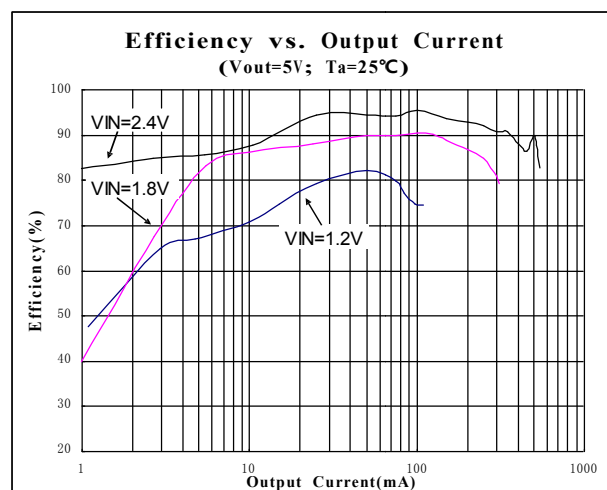
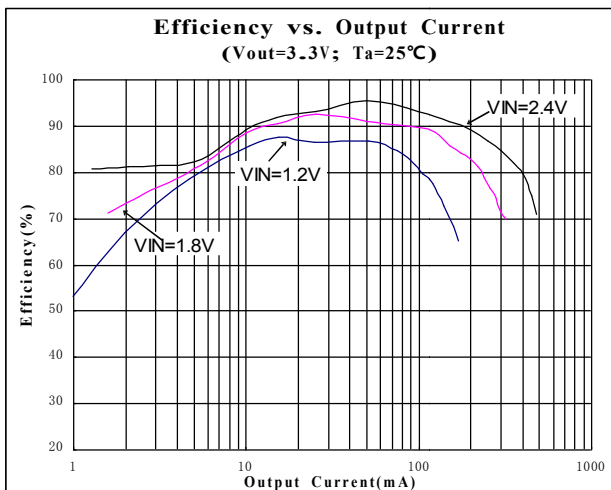

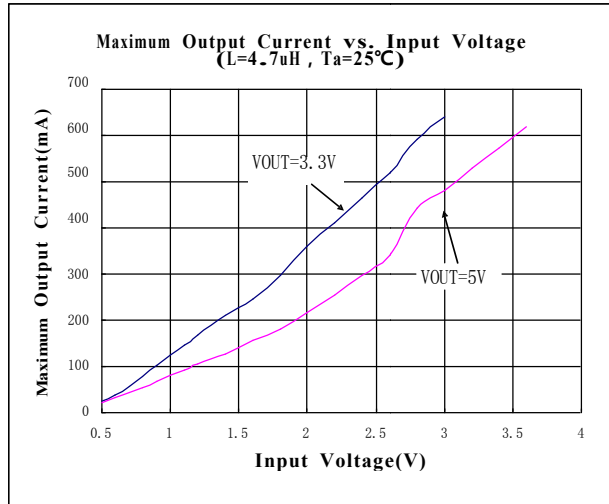
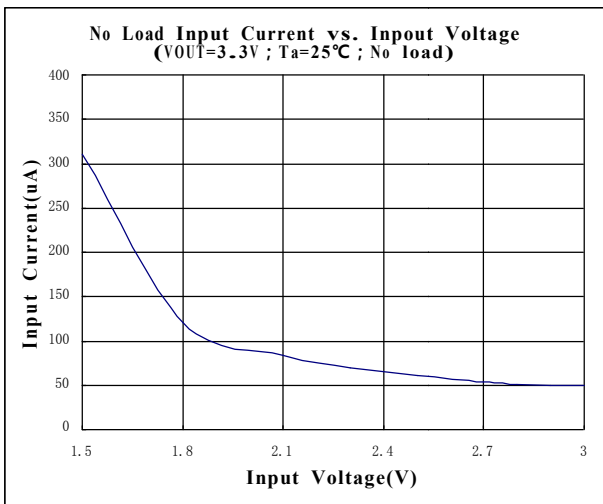
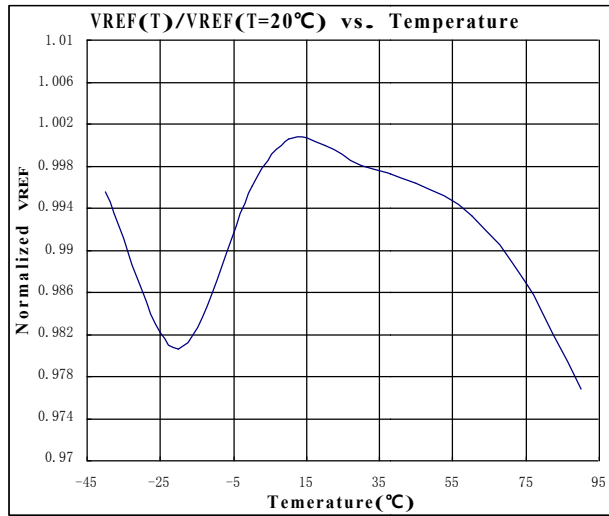
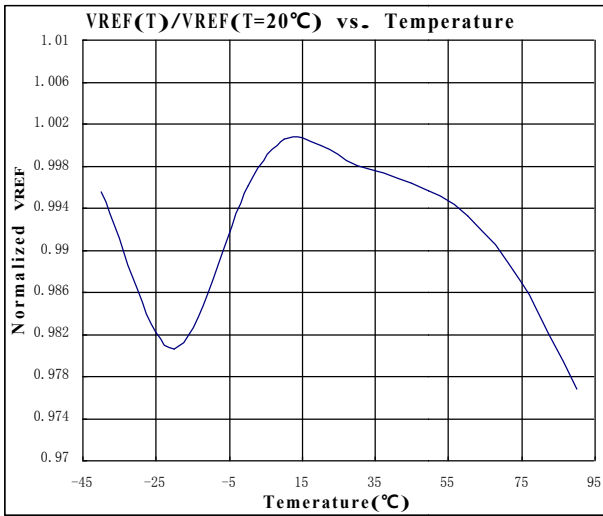

BLOCK DIAGRAM

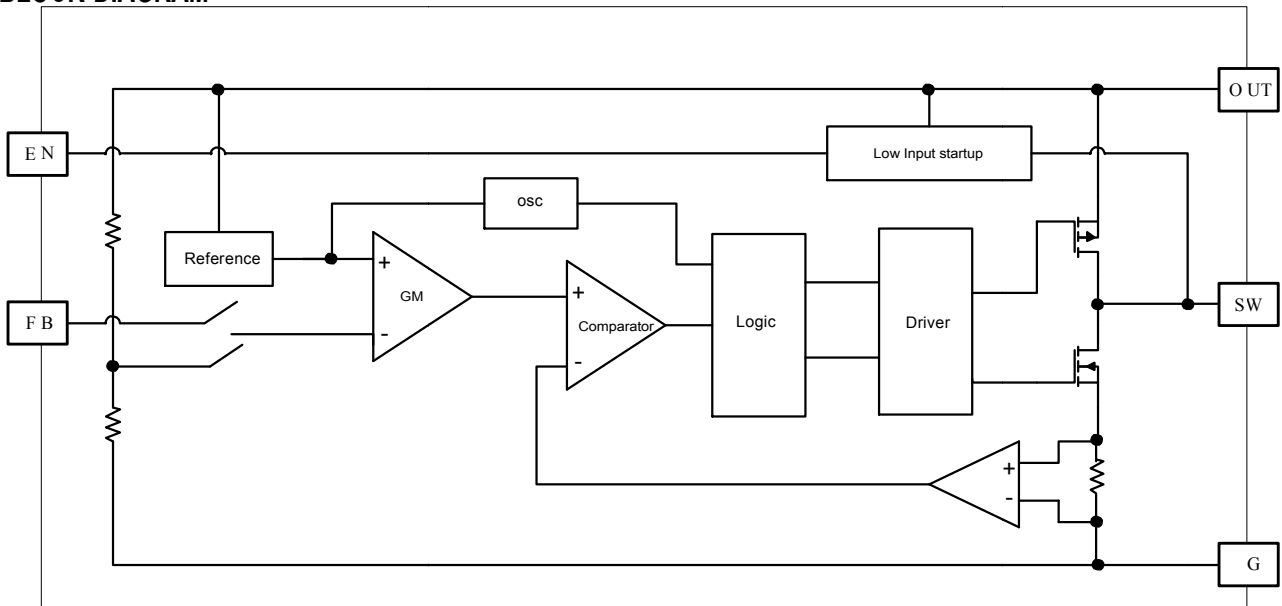

DETAIL DESCRIPTION

BL8542C is a low input voltage start up, current mode dc-dc step up converter. It's operation can be best understood by referring to the block diagram. Upon starting up, the low voltage startup circuitry drives SW with on-off cycles, transferring energy from input to OUT by storing energy in the inductor during on-time and releasing it to the output during off-time. When OUT reaches 2V, the startup circuit turns off and the main controller takes over. The main control loop consists of a reference, a GM error amplifier, a PWM controller, a current sense amplifier, an oscillator, a PWM logic control, and it is power stage including its driver. The main control loop is a classic current mode control loop. The GM stage integrates the error between FB and REF, and its output is used to compare with a triangular wave which the summing result of the current sense amplifier output and a slope compensation voltage. The output of the comparator is used to drive the power stage to reach regulation.

APPLICATION INFORMATION

Output Voltage selection

The output voltages can be set by connecting FB to OUT, to G or to the midpoint of a resistor divider connected to OUT.

See below table for details.

FB=G	$V_{OUT} = 5.0V$
FB=OUT	$V_{OUT} = 3.3V$
FB to resistor divider	$V_{OUT} = 0.6V(1+R1/R2)$

Inductor selection

With switching frequency up to 1MHz, small surface mount inductors can be used with values from 2.2uH to 4.7uH. For a given chosen inductor value and application conditions make sure the peak inductor current does not exceed the maximum current rating of the selected vendor's inductor.

Input and output capacitor selection

The BL8542C's bootstrap architecture allows the use of very small input capacitors. For applications that only need to drive small output load current, the input capacitor is optional, because once output is started up, the IC's is powered by OUT, a quiet power supply.

The output capacitor is used to stabilize the loop and provide ac current to the load. A low ESR ceramic cap with values from 2.2uF to 22uF can be used. Smaller value capacitors are generally cheaper with small footprints, while larger capacitor provides lower ripples and better transient load responses. Also, when extreme low startup voltage is needed, larger output capacitors are needed for the part to startup under heavy load condition.

PACKAGE OUTLINE

5LD SOT-23 PACKAGE OUTLINE DIMENSION

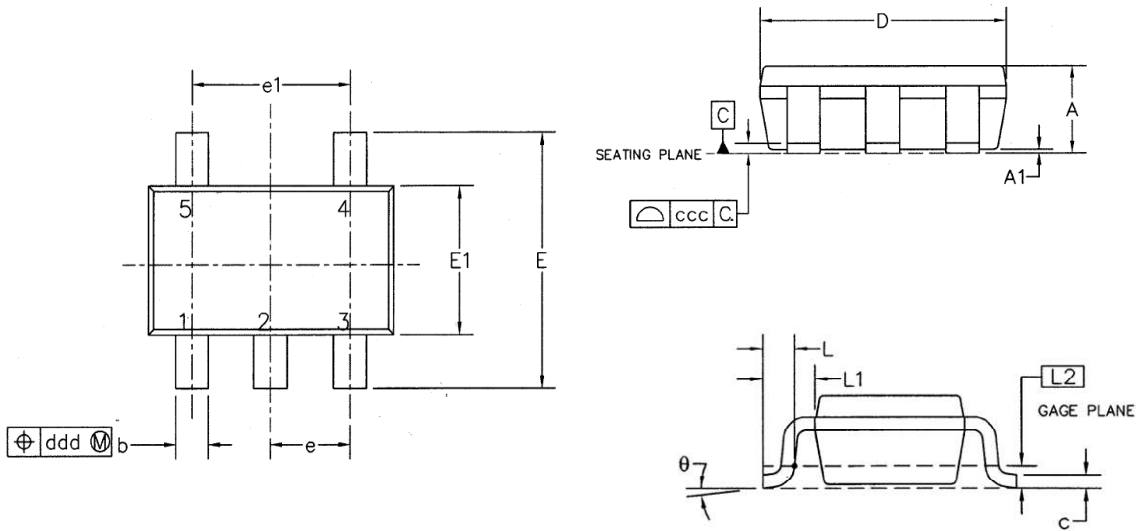

NOTE : PACKAGE OUTLINE EXCLUSIVE OF MOLD FLASH AND METAL BURR.

All dimensions in mm.

Dimensions			JEDEC: MO-193 Rev:C		
	Min.	Max.	Min.	Nom.	Max.
A	0.90	1.10	-	-	1.10
A1	0.01	0.10	0	-	0.10
b	0.30	0.50	0.30	-	0.50
c	0.09	0.20	0.08	-	0.20
D	2.90BSC		2.90BSC		
E	2.60	3.00	2.80BSC		
E1	1.60BSC		1.60BSC		
e	0.95BSC		0.95BSC		
e1	1.90BSC		1.90BSC		
L	0.30	0.55	0.30	0.45	0.60
L1	0.60 REF		0.60 REF		
L2	0.25BSC		0.25BSC		
θ	0°	8°	0°	4°	8°
ccc	0.10		0.10		
ddd	0.20		0.20		

X-ON Electronics

Largest Supplier of Electrical and Electronic Components

Click to view similar products for [Isolated DC/DC Converters](#) category:

Click to view products by [Belling](#) manufacturer:

Other Similar products are found below :

[ESM6D044440C05AAQ](#) [FMD15.24G](#) [PSL486-7LR](#) [PSR152.5-7IR](#) [Q48T30020-NBB0](#) [AVO240-48S12B-6L](#) [AVO250-48S28B-6L](#) [NAN-0505](#) [HW-L16D](#) [JAHW100Y1](#) [217-1617-001](#) [22827](#) [SPB05C-12](#) [SQ24S15033-PS0S](#) [18952](#) [19-130041](#) [CE-1003](#) [CE-1004](#) [GQ2541-7R](#) [PSE1000DCDC-12V](#) [RDS180245](#) [MAU228](#) [419-2065-201](#) [449-2075-101](#) [TME 0303S](#) [TME 0505S](#) [TME 1205S](#) [TME 1212S](#) [TME 2405S](#) [TME 2412S](#) [V300C24C150BG](#) [419-2062-200](#) [419-2063-401](#) [419-2067-101](#) [419-2067-501](#) [419-2068-001](#) [DCG40-5G](#) [DFC15U48D15](#) [449-2067-000](#) [XGS-0512](#) [XGS-1205](#) [XGS-1212](#) [XGS-2412](#) [XGS-2415](#) [XKS-1215](#) [033456](#) [NCT1000N040R050B](#) [SPB05B-15](#) [SPB05C-15](#) [TME 0509S](#)