

250mA Low Consumption Linear Regulator

DESCRIPTION

BL8061 series is a group of positive voltage output, low power consumption, low dropout voltage, three terminal regulator. It can provide 200mA output current when input / output voltage differential drops to 420mV ($V_{out}=3.3V$), And it also provides foldback short-circuit protection and output current limit function. The very low power consumption of BL8061 ($I_q=2.0\mu A$) can greatly improve natural life of batteries.

BL8061 can provide output value in the range of 1.1V~5.0V in 0.1V steps. It also can customized on command.

BL8061 includes high accuracy voltage reference, error amplifier, current limit circuit and output driver module.

BL8061 has well load transient response and good temperature characteristic, And it uses trimming technique to guarantee output voltage accuracy within $\pm 2\%$.

TYPICAL APPLICATION

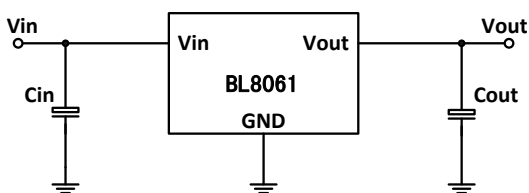

NOTE: Input capacitor ($C_{in}=1\mu F$) and Output capacitor ($C_{out}=1\mu F$) are recommended in all application circuit. Ceramic capacitor is recommended.

FEATURES

- Low Power Consumption: $2.0\mu A$ (Typ.)
- Maximum Output Current: 250mA
- Small Dropout Voltage
210mV@100mA ($V_{out}=3.3V$)
420mV@200mA ($V_{out}=3.3V$)
- Input Voltage Range: 2V~16V
- Output Voltage Range: 1.1V~5.0V (customized on command in 0.1V steps)
- Highly Accurate: $\pm 2\%$ ($\pm 1\%$ customized)
- Output Current Limit
330mA@ $V_{out}=3.3V$
- Foldback Short-circuit Current
56mA@ $V_{out}=3.3V$

APPLICATIONS

- Battery Powered equipment
- Power Management of MP3、PDA、DSC、Mouse、PS2 Games
- Reference Voltage Source Regulation after Switching Power

ELECTRICAL CHARACTERISTICS

Vout Voltage vs Load Current

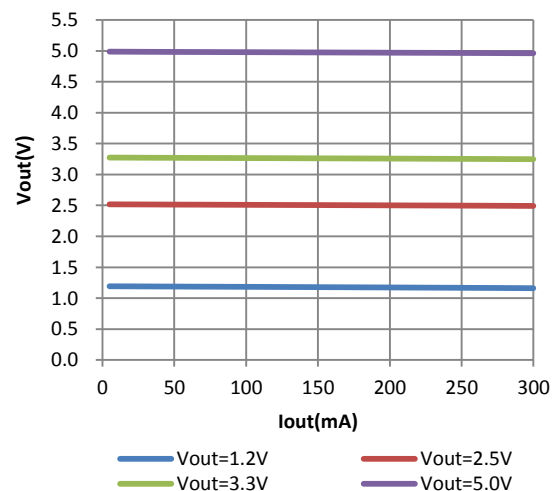

BL8061

ORDERING INFORMATION

BL8061 ①②③④⑤

Code	Description
①	Temperature&Rohs: C:-40~85°C ,Pb Free Rohs Std.
②	Package type: B3:SOT-23-3 B5:SOT-23-5 C3:SOT-89-3 C3B:SOT-89-3 (B)
③	Packing type: TR:Tape&Reel (Standard)
④	Output voltage: e.g. 11=1.1V 15=1.5V 55=5.5V
⑤	Voltage accuracy: 1=±1% Blank(default)=±2%

MARKING DESCRIPTON

M: Product Code

X: Output Voltage

Output Voltage Code

VOUT	Code	VOUT	Code	VOUT	Code
1.1V	1	2.9V	9	4.3V	3
1.2V	2	3.0V	0	4.4V	4
1.3V	3	3.1V	1	4.5V	5
1.5V	5	3.2V	2	4.6V	6
1.8V	8	3.3V	3	4.7V	7
2.0V	0	3.4V	4	4.8V	8
2.1V	1	3.5V	5	4.9V	9
2.2V	2	3.6V	6	5.0V	0
2.3V	3	3.7V	7	5.1V	1
2.4V	4	3.8V	8	5.2V	2
2.5V	5	3.9V	9	5.3V	3
2.6V	6	4.0V	0	5.4V	4
2.7V	7	4.1V	1	5.5V	5
2.8V	8	4.2V	2		

Y: The Year of manufacturing, "1" stands for year 2011, "2" stands for year 2012, and "8" stands for year 2018.

W: The week of manufacturing. "A" stands for week

1, "Z" stands for week 26, "A" stands for week 27, "Z" stands for week 52.

PIN CONFIGURATION

Product Classification		BL8061CB3TR□□□
Marking		SOT-23-3
MXYW	M:Product Code	
	X:Output Voltage	
	YW: Date Code	
Product Classification		BL8061CB5TR□□□
Marking		SOT-23-5
MXYW	M:Product Code	
	X: Output Voltage	
	YW: Date Code	
Product Classification		BL8061CC3TR□□□
Marking		SOT-89-3
MXX LLBYW	M:Product Code	
	XX: Output Voltage	
	LL: LOT NO.	
	B:FAB Code	
Product Classification		BL8061CC3BTR□□□
Marking		SOT-89-3
MXXI LLBYW	M:Product Code	
	XX: Output Voltage	
	LL: LOT NO.	
	B:FAB Code	
Product Classification		BL8061CC3BTR□□□
Marking		SOT-89-3
MXXI LLBYW	M:Product Code	
	XX: Output Voltage	
	LL: LOT NO.	
	B:FAB Code	
Product Classification		BL8061CC3BTR□□□
Marking		SOT-89-3
MXXI LLBYW	M:Product Code	
	XX: Output Voltage	
	LL: LOT NO.	
	B:FAB Code	
Product Classification		BL8061CC3BTR□□□
Marking		SOT-89-3
MXXI LLBYW	M:Product Code	
	XX: Output Voltage	
	LL: LOT NO.	
	B:FAB Code	
Product Classification		BL8061CC3BTR□□□
Marking		SOT-89-3
MXXI LLBYW	M:Product Code	
	XX: Output Voltage	
	LL: LOT NO.	
	B:FAB Code	

ABSOLUTE MAXIMUM RATING

Parameter		Value
Max Input Voltage		20V
Operating Junction Temperature(Tj)		125°C
Ambient Temperature(Ta)		-40°C -85°C
Power Dissipation	SOT-23-3	250mW
	SOT-23-5	250mW
	SOT-89-3	500mW
Storage Temperature(Ts)		-40°C -150°C
Lead Temperature & Time		260°C,10S

Note:

Exceed these limits to damage to the device.

Exposure to absolute maximum rating conditions may affect device reliability.

RECOMMENDED WORK CONDITIONS

Item	Min	Recommended	Max.	Unit
Input Voltage Range			16	V
Ambient Temperature	-40		85	°C

ELECTRICAL CHARACTERISTICS

(Test Conditions: Cin=1uF, Cout=1uF, TA=25°C, Unless Otherwise Specified)

Symbol	Parameter	Conditions	Min	Type	Max	Units
Vin	Input Voltage				16	V
Vout	Output Voltage		Vout x0.98		Vout X1.02	V
Iout(Max.)	Maximum Output Current	Vin-Vout=1V	250			mA
Dropout Voltage	Input-Output Voltage Differential	Iout=100mA	Vout ≤ 2.5V	600	1000	mV
			Vout ≥ 2.5V	300	600	
$\frac{\Delta V_{out}}{\Delta V_{in} \cdot V_{out}}$	Line Regulation	Iout=10mA 2V≤Vin≤16V		0.2	0.3	%/V
ΔV_{out}	Load Regulation	Vin=Set Vout+1V 1mA≤Iout≤100mA		20	40	mV
Iq	Quiescent Current	Vin=Set Vout+1V		2.0	5.0	uA
$\frac{\Delta V_{out}}{\Delta T \cdot V_{out}}$	Output Voltage Temperature Coefficient	Iout=10mA		100		ppm/°C

BLOCK DIAGRAM

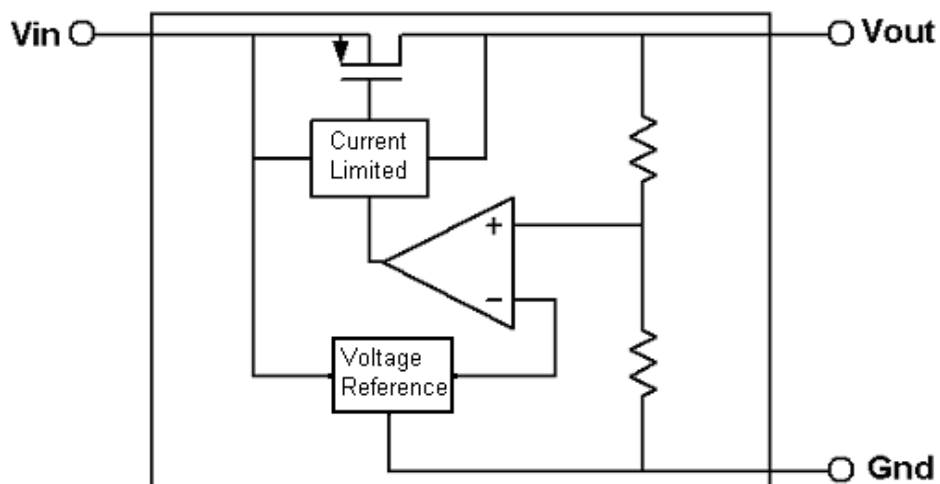

EXPLANATION

BL8061 is a series of low dropout voltage and low power consumption three pins regulator. Its application circuit is very simple, which only needs two outside capacitors. It is composed of these modules: high accuracy voltage reference, current limit circuit, error amplifier, output driver and power transistor.

Current Limit module can keep chip and power system away from danger when load current is more than 250mA.

BL8061 uses trimming technique to assure the accuracy of output value within $\pm 2\%$, at the same time, temperature compensation is elaborately considered in this chip, which makes BL8061's temperature coefficient within $100\text{ppm}/^\circ\text{C}$.

TYPICAL PERFORMANCE CHARACTERISTICS

Vout Voltage vs Load Current

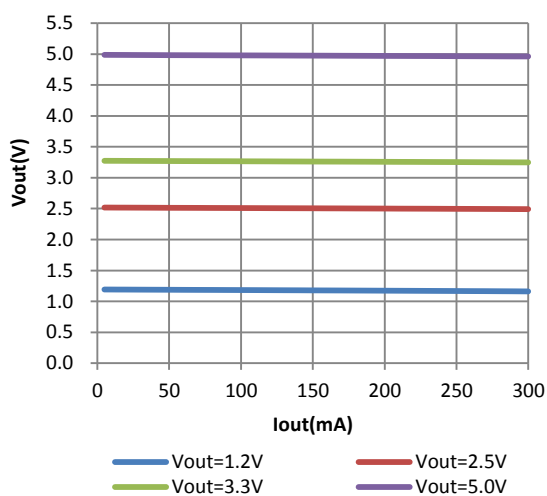

Line Regulation

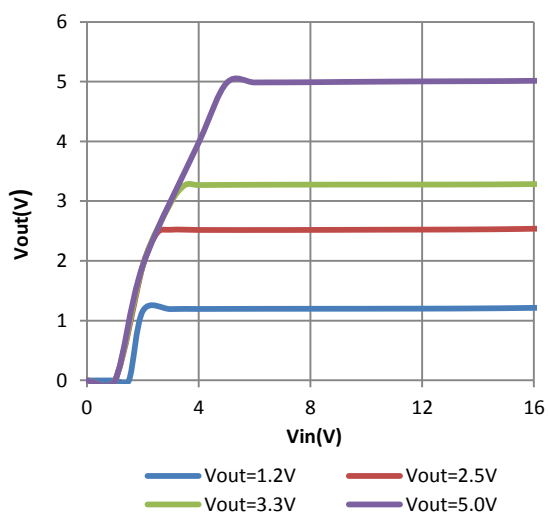

Dropout Voltage vs Load Current

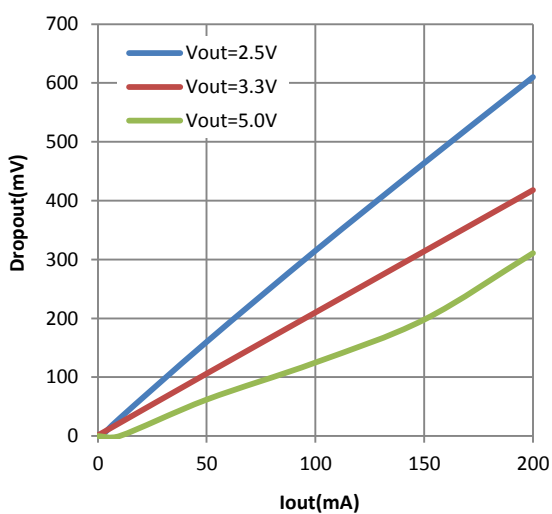

Iq

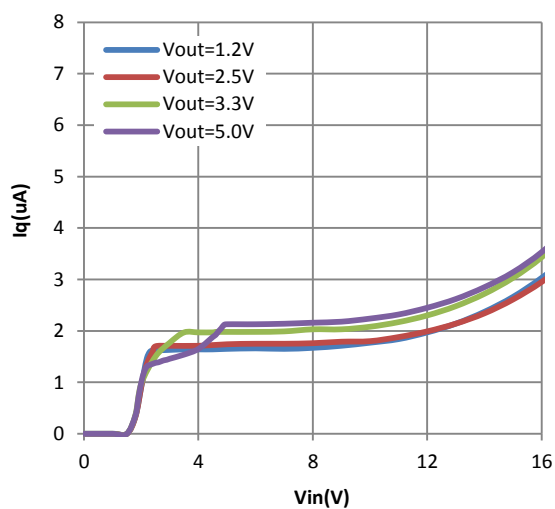

Current Limit

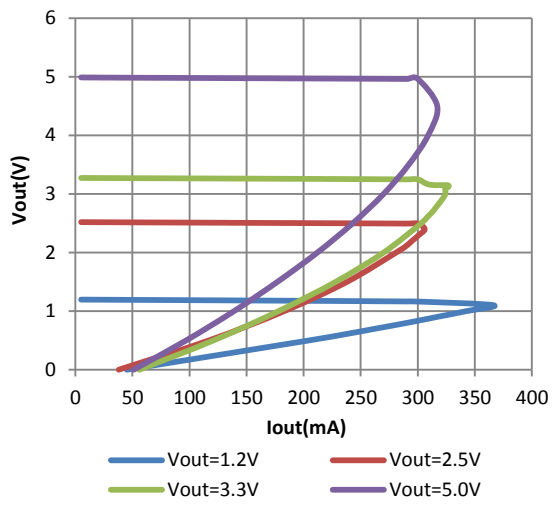

Line transient response

Vin=6V~7V, Ch1—Vout, Ch3—Vin

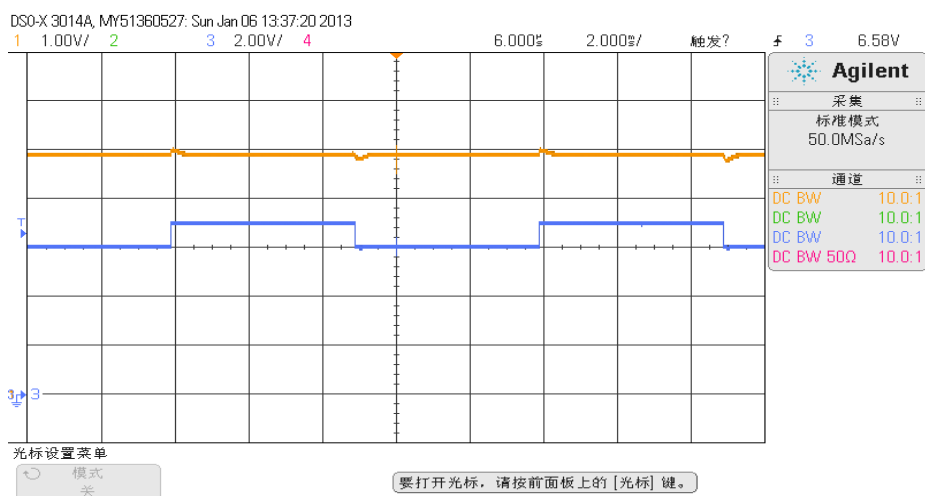

Load transient response

Iout=1mA~100mA, Ch1—Vout, Ch4—Iout

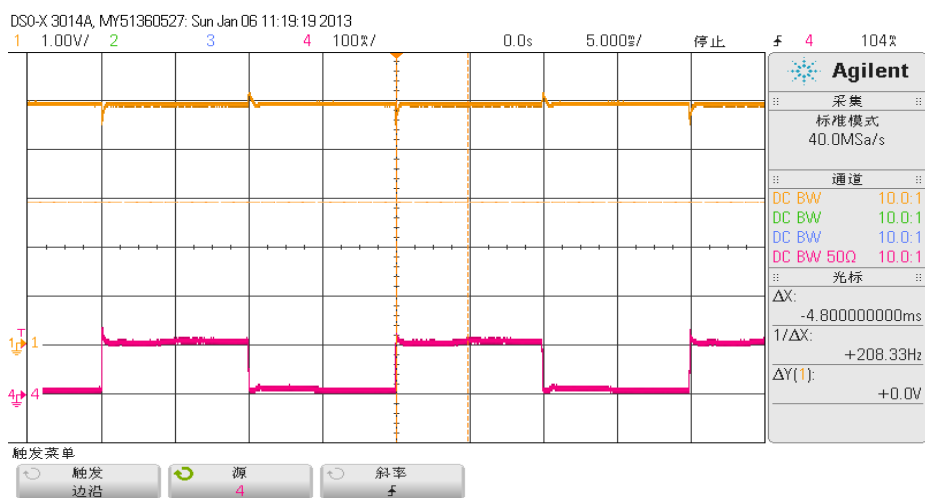

Start up

Ch1—Vout, Ch3—Vin

DSO-X 3014A, MY51360527, Sun Jan 06 11:30:56 2013

1 2.00V/ 2 3 2.00V/ 4 -60.00% 100.0%/ 停止 f 1 4.00V

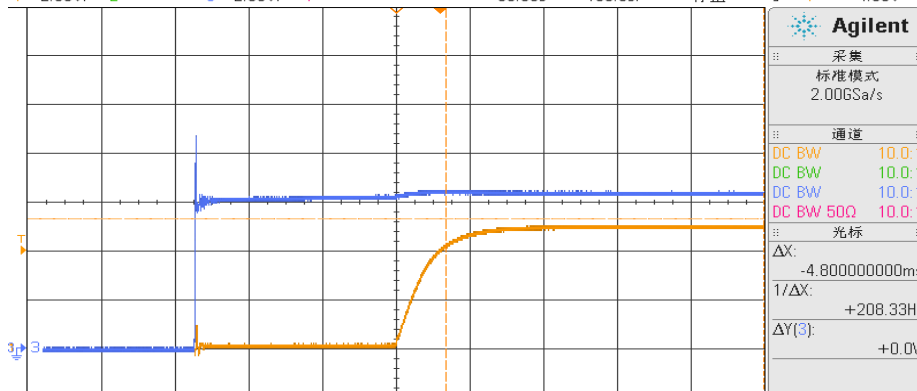

触发菜单

触发菜单

← 触发 1
边沿

↻ 源

↻ 斜率 f

PACKAGE LINE

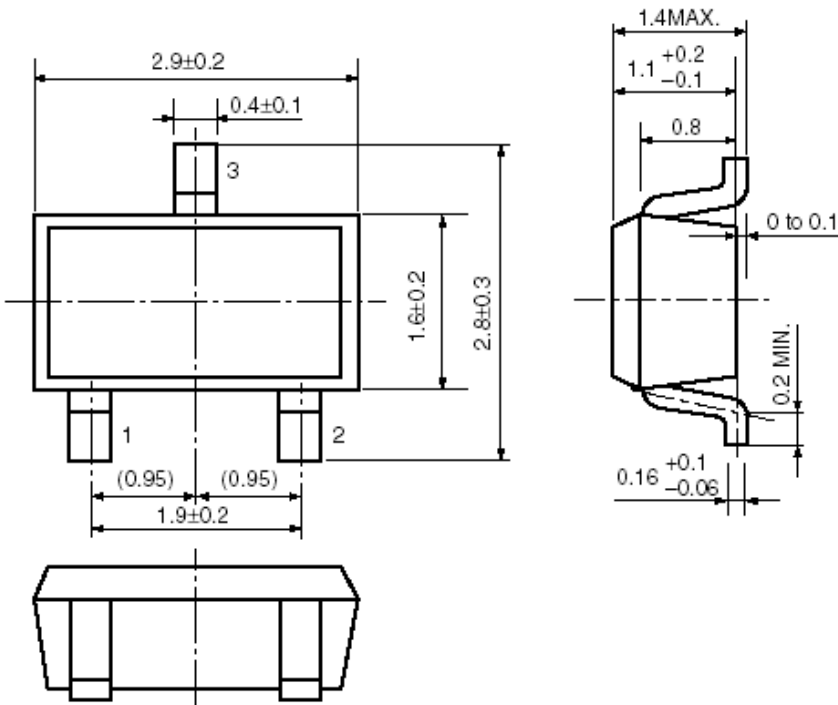
Package	SOT-23-3	Devices per reel	3000Pcs	Unit	mm
Package dimension:  <p> The technical drawing shows three views of the SOT-23-3 package: <ul style="list-style-type: none"> Top View: Shows a rectangular body with a width of 2.9 ± 0.2 mm and a length of 1.9 ± 0.2 mm. The distance between the two leads (1 and 2) is 1.9 ± 0.2 mm, with each lead offset by 0.95 mm from the center. The lead width is 0.4 ± 0.1 mm. The package height is 1.6 ± 0.2 mm, and the total height including the lead is 2.8 ± 0.3 mm. A third lead (3) is located at the top, with a width of 0.4 ± 0.1 mm. Side View: Shows the profile of the package. The maximum width is 1.4 mm. The lead height is 1.1 mm with a tolerance of $+0.2$ to -0.1 mm. The lead width is 0.8 mm. The lead thickness is 0.2 mm minimum. The lead angle is 0 to 0.1 degrees. The lead length is 0.16 mm with a tolerance of $+0.1$ to -0.06 mm. Perspective View: Shows the package from an isometric perspective. </p>					
Package	SOT-23-5	Devices per reel	3000Pcs	Unit	mm

Package Dimension:

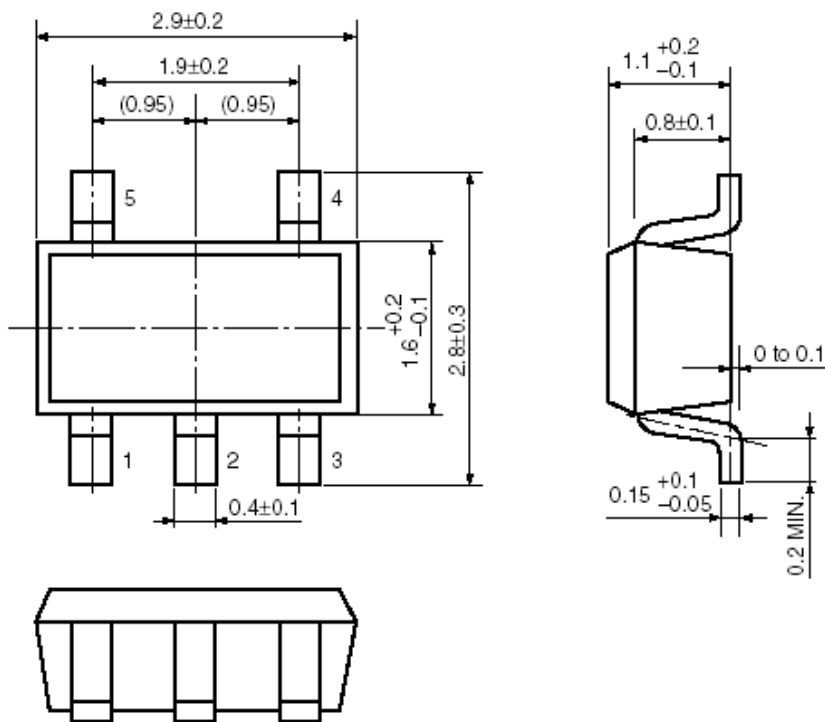

Package	SOT-89-3	Devices per reel	1000Pcs	Unit	mm
---------	----------	------------------	---------	------	----

Package Dimension:

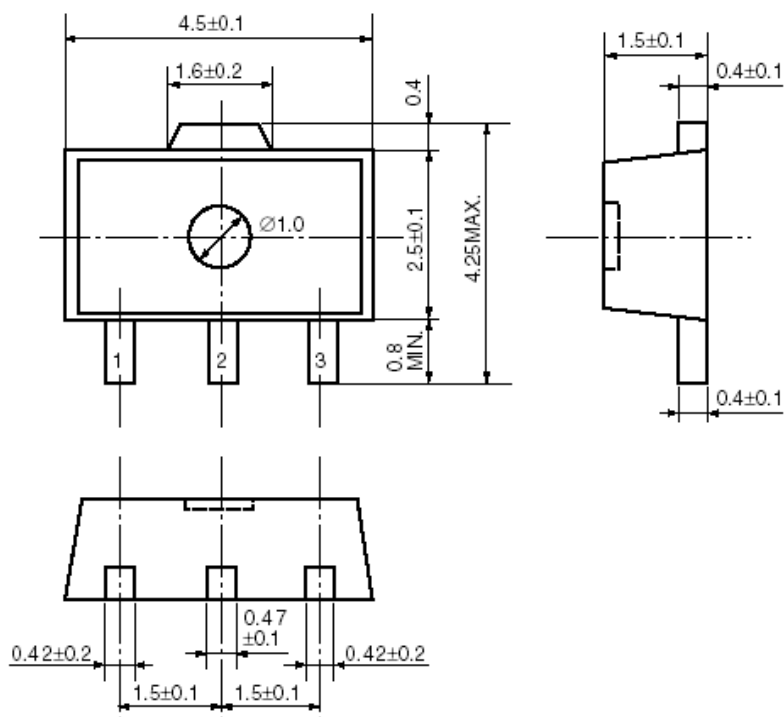

X-ON Electronics

Largest Supplier of Electrical and Electronic Components

Click to view similar products for [Linear Voltage Regulators](#) category:

Click to view products by [Belling](#) manufacturer:

Other Similar products are found below :

[LV56831P-E](#) [LV5684PVD-XH](#) [MAX202ECWE-LF](#) [MCDTSA6-2R](#) [L4953G](#) [L7815ACV-DG](#) [PQ3DZ53U](#) [LV56801P-E](#)
[TCR3DF13,LM\(CT](#) [TCR3DF39,LM\(CT](#) [TLE42794G](#) [L78L05CZ/1SX](#) [L78LR05DL-MA-E](#) [L78MR05-E](#) [033150D](#) [033151B](#) [090756R](#)
[636416C](#) [NCV78M15BDTG](#) [702482B](#) [714954EB](#) [TLE42794GM](#) [TLE42994GM](#) [ZMR500QFTA](#) [BA033LBSG2-TR](#)
[NCV78M05ABDTRKG](#) [NCV78M08BDTRKG](#) [NCP7808TG](#) [NCV571SN12T1G](#) [LV5680P-E](#) [CAJ24C256YI-GT3](#) [L78M15CV-DG](#) [L9474N](#)
[TLS202B1MBV33HTSA1](#) [L79M05T-E](#) [NCP571SN09T1G](#) [MAX15006AASA/V+](#) [MIC5283-5.0YML-T5](#) [L4969URTR-E](#) [L78LR05D-MA-E](#)
[NCV7808BDTRKG](#) [L9466N](#) [NCP7805ETG](#) [SC7812CTG](#) [NCV7809BTG](#) [NCV571SN09T1G](#) [NCV317MBTG](#) [MC78M15CDTT5G](#)
[MC78M12CDTT5G](#) [L9468N](#)