

SPECIFICATION FOR APPROVAL

CN: 1702001982

CUSTOMER	:	_____
PRODUCT TYPE	:	SMD SEAM SEALING XTAL 5.0 × 3.2
NOMINAL FREQ.	:	10.000000MHz
TXC P/N	:	AB10000301
REVISION	:	S1
CUSTOMER P/N	:	_____
PM / SALES	:	_____
DATE	:	_____
CUSTOMER CONFIRMATION	:	_____

- (1) TXC requires one copy returned with signature and title of authorized individual that signifies acceptance of the attached specifications.
- (2) Orders received and accepted by TXC after return of signed copy of specification will be produced per these specifications.
- (3) Any changes to these specifications must be agreed upon by both parties and new revision of the Product Specification Sheet will be issued.
- (4) Any issuance of purchase order prior to consigning back the Approval page of "Specification Sheets" from customers will be regarded as the agreement on the contents of these specifications.

MSL:Level 1
RoHS Compliant

(for glass crystal only:Pb used in sealing glass material is exempt from EU directive)

PRODUCT SPECIFICATION SHEET

CN: 1702001982

PRODUCT TYPE : SMD SEAM SEALING XTAL 5.0 × 3.2

NOMINAL FREQ. : 10.000000MHz

TXC P/N : AB10000301

REVISION : S1

PE/RD	QA	MFG
<i>Wen yuan Chang</i> wen yuan Chang		
20-Nov-16		

NOTE:

(1)The green product standard set by TXC is based upon the international standards. Related information is publicly described on the TXC's Website, and updated regularly. The document is compliant with the latest green product quality system directives at the time.

(2)Revision "Sx" is for engineering samples only. PE/RD's approval required.

(3)Revision "Ax" is production ready. PE, QA and MFG's approval required

MSL:Level 1

RoHS Compliant

(for glass crystal only:Pb used in sealing glass material is exempt from EU directive)

■ ELECTRICAL SPECIFICATIONS

Standard atmospheric conditions

Unless otherwise specified, the standard range of atmospheric conditions for making measurement and tests are as follow:

Ambient temperature : 25±5°C
 Relative humidity : 40%~70%

If there is any doubt about the results, measurement shall be made within the following limits:

Ambient temperature : 25±3°C
 Relative humidity : 40%~70%

Measure equipment

Electrical characteristics measured by S&A 250B or equivalent.

Crystal cutting type

The crystal is using AT CUT (thickness shear mode).

Unit Weight:

0.046±0.002 g/pcs

	Parameters	SYM.	Electrical Spec.				Notes
			MIN	TYPE	MAX	UNITS	
1	Nominal Frequency	FL	10.000000			MHz	-
2	Oscillation Mode	-	Fundamental			-	-
3	Load Capacitance	CL	12			pF	-
4	Frequency Tolerance	-	±30			ppm	at 25 °C ± 3 °C
5	Frequency Stability	-	±100			ppm	Over Operating Temp. Range (Reference 25°C)
6	Operating Temperature	-	-40	~	125	°C	-
7	Aging	-	-3	~	3	ppm	1st Year
8	Drive Level	DL	-	50	100	μW	-
9	Effective Resistance	Rr	-	-	80	Ω	-
10	Shunt Capacitance C0	C0	-	-	5	pF	-
11	Insulation Resistance	-	500	-	-	MΩ	at DC 100V
12	Storage Temperature Range	-	-40	~	125	°C	-

■ DIMENSIONS

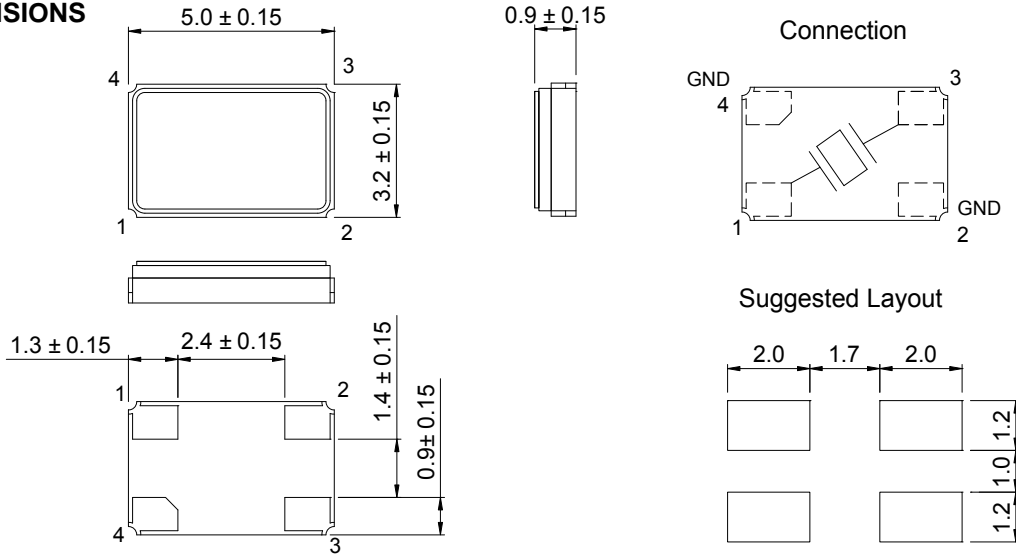

*Coplanarity of solderable areas Camber 0.10 mm Max

■ MARKING

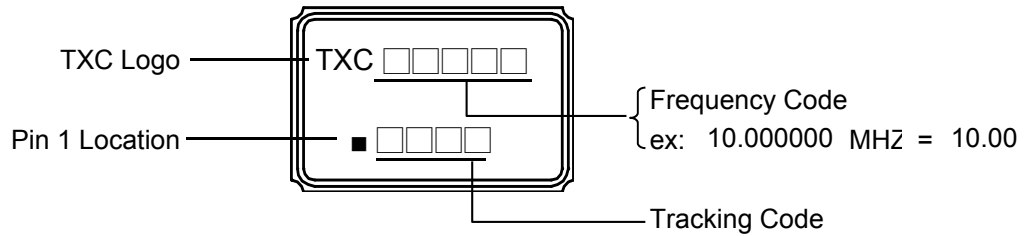

Production location: China or Taiwan

■ SUGGESTED REFLOW PROFILE

Total time : 200 sec. Max.
Solder melting point :220 °C

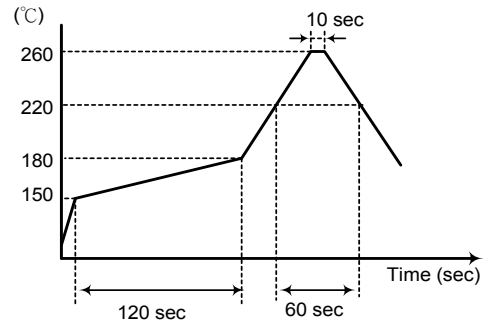

■ STRUCTURE ILLUSTRATION

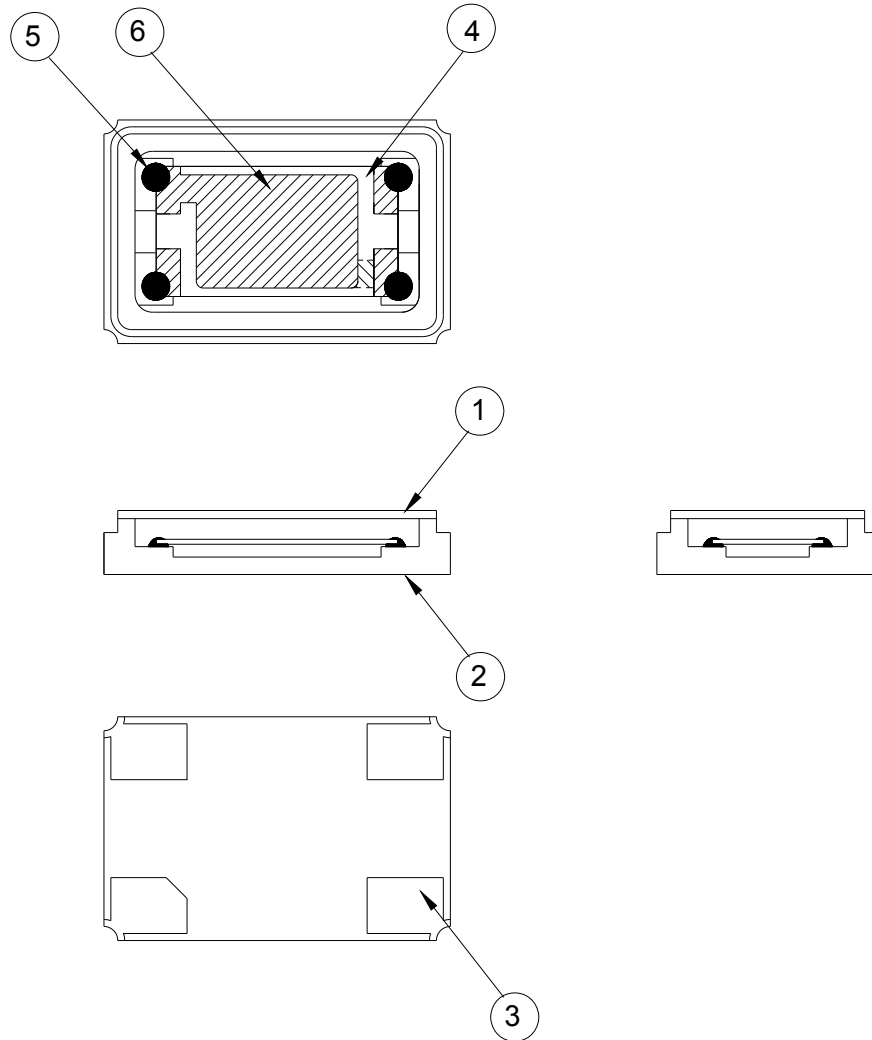

NO	COMPONENTS	MATERIALS	FINISH/SPECIFICATIONS
1	Lid	Kovar (Fe/Co/Ni)	-
2	Package	Ceramic (Al ₂ O ₃) + Kovar (Fe/Co/Ni)+ Ag/Cu	-
3	PAD	Au	Tungsten metalize + Ni plating + Au plating
4	Crystal blank	SiO ₂	-
5	Conductive adhesive	Ag+Silicon	-
6	Electrode	Noble Metal	-

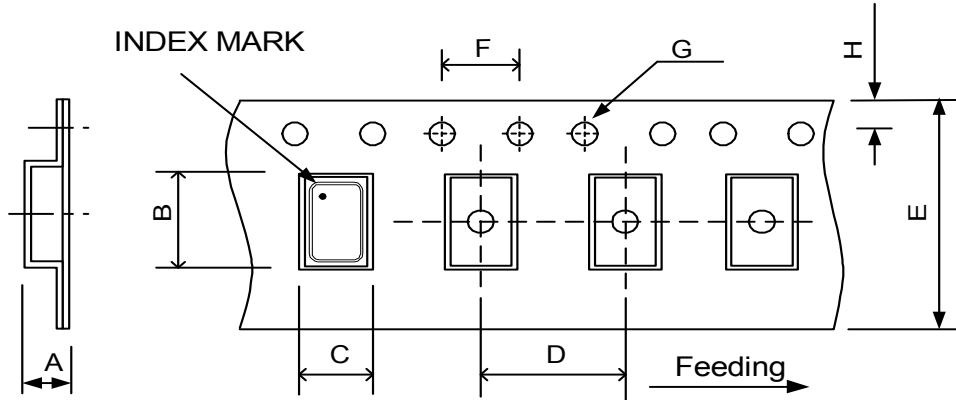
PACKING

DIMENSIONS	A	B	C	D	E	F	G	H	(UNIT : mm)
	1.65±0.10	5.40±0.10	3.50±0.10	8.00±0.10	12.00±0.30	4.00±0.10	1.55±0.10	1.75±0.10	

REMARK :

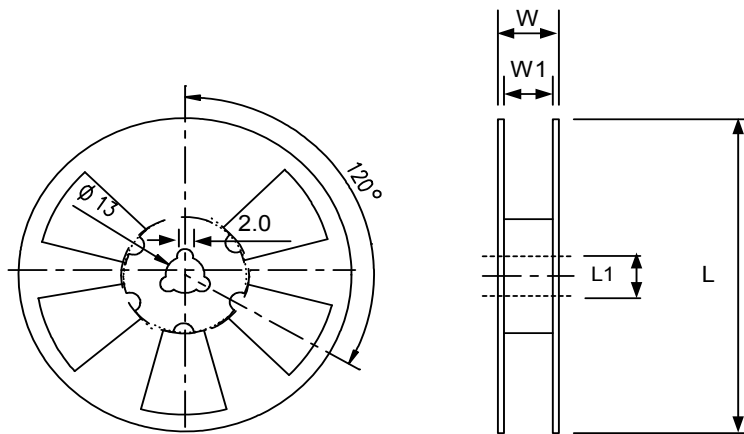
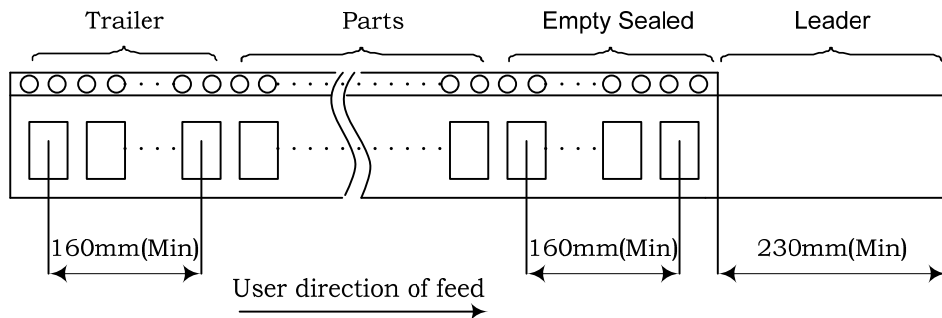

DIMENSIONS	L	L1	W	W1	pcs / Reel (UNIT : mm)
	180±1.00	13±0.50	16.5±0.20	12±0.10	Standard Reel Quantity is 1,000 pcs per reel

■ RELIABILITY SPECIFICATIONS (AEC-Q200 Compliant)

1. Mechanical Endurance

No.	Test Item	Test Methods	REF.DC
1.1	Drop Test	120 cm height, 20 times on Stainless Plate .	JIS C 67
1.2	Mechanical Shock	Device are shocked to half sine wave (5000 G) three mutually perpendicular axes each 3 times. 0.3m sec. duration time	MIL-STD-Method 2
1.3	Vibration	Frequency range 10 ~ 2000 Hz~10 Hz Amplitude 1.52 mm/20G Sweep time 20 minute Perpendicular axes each test time 4 Hrs (Total test time 12 Hrs)	MIL-STD-Method 2
1.4	Solderability	Temperature 245 °C ± 5°C Immersing depth 1.25 mm Immersion time 5 ± 1 seconds Flux Rosin resin methyl alcohol solvent (1 : 4)	J-STD-0
1.5	Terminal Strength	Mount on PCB board and shear strength 1.8kg for 60 sec.	AEC-Q200
1.6	Board Flex	Duration Time: 60 sec, Deviation: 3mm	AEC-Q200

2.Environmental Endurance

No.	Test Item	Test Methods	REF. DC
2.1	Resistance To Soldering Heat	Pre-heat temperature 125 °C Pre-heat time 60 ~ 120 sec. Test temperature 260 ± 5 °C Test time 10 ± 1 sec.	MIL-STD-Method 2
2.2	High Temp. Storage	+ 125 °C ± 3 °C for all 1000 Hrs.	MIL-STD-Method 1
2.3	Low Temp. Storage	- 40 °C ± 3 °C for all 1000 Hrs.	JIS C 67
2.4	Thermal Shock	Total 1000 cycles of the following Thermal Shock : 	MIL-STD-Method 1
2.5	Temperature Cycle	Total 1000 cycles of the following temperature cycle : - 40°C ± 3 to 125°C ± 3 , Dwell time:15min.	JESD 2 Method JA
2.6	Biased Humidity	+ 85°C ± 3°C , RH 85% , 1000 Hrs.	MIL-STD-Method 1
2.7	Moisture Resistance	20 cycles (+25°C~65°C , 80%~100% RH) , 24hrs/cycle.	MIL-STD-Method 1
2.8	Operational Life	+ 125 °C ± 3 °C for 1000 Hrs.	MIL-STD-Method 1

1

er

iang

c)

5

mm)



6

DC
'01
-202
213
-202
204
02
-006
-005

DC
202
210
-202
108
'01
-202
107
2
-104
-202
103
202
106
-202
108

X-ON Electronics

Largest Supplier of Electrical and Electronic Components

Click to view similar products for [Crystals category](#):

Click to view products by [TXC Corporation manufacturer](#):

Other Similar products are found below :

[CS325S24000000ABJT](#) [718-13.2-1](#) [MC405 32.0000K-R3:PURE SN](#) [FC-135R 32.7680KF-A3](#) [7A-40.000MAAE-T](#) [7B-27.000MBBK-T](#)
[FL2000085](#) [9B-15.360MBBK-B](#) [9C-7.680MBBK-T](#) [ASH7K-32.768KHZ](#) [AT-41.600MAGQ-T](#) [BTD1062E05A-513](#) [LFX TAL066198Cutt](#)
[9C-14.31818MBBK-T](#) [FA-238 50.0000MB30X-K3](#) [FC-12M 32.7680KA-AC3](#) [SSPT7F-9PF20-R](#) [FX325BS-38.88EEM1201](#)
[LFX TAL065253Cutt](#) [LFX TAL066431Cutt](#) [XT9S20ANA14M7456](#) [XT9SNLANA16M](#) [646G-24-2](#) [7A-24.576MBBK-T](#) [7B-30.000MBBK-T](#)
[WX26-32.768K-6PF](#) [9B-14.31818MBBK-B](#) [CD1AM](#) [7B-25.000MAAE-T](#) [7A-14.31818MBBK-T](#) [6504-202-1501](#) [6526-202-1501](#) [FA-118T](#)
[27.1200MB50P-K0](#) [FC-135R 32.7680KA-A3](#) [ABM12-104-37.400MHZT](#) [ABLS-10.000MHZ-D3W-T](#) [BTJ112E01E-513](#) [BTJ722K01C-7067](#)
[BTL-20-513](#) [TSX-3225 24.0000MF15X-AC](#) [TSX-3225 16.0000MF18X-AC](#) [BTJ120E02C](#) [BTL-12-513](#) [7A-10.000MBBK-T](#) [7A-](#)
[11.0592MBBK-T](#) [ABM12-103-24.000MHZT](#) [CS325S25000000ABJT](#) [ABM3B-25.000MHZ-B2-X-T](#) [FC-135 32.7680KA-A5](#) [FX0800015](#)