



TXC CORPORATION

4F, NO. 16, Sec. 2 Chung Yang S Rd., Peitou, Taipei, Taiwan.

TEL : 886-2-2894-1202 , 886-2-2895-2201 FAX : 886-2-2894-1206 , 886-2-2895-6207

www.txccorp.com

SPECIFICATION FOR APPROVAL

CN: 1307000713

CUSTOMER	:	_____
PRODUCT TYPE	:	HC-49/S SMD
NOMINAL FREQ.	:	27.000000MHz
TXC P/N	:	AT27000001
REVISION	:	A2
CUSTOMER P/N	:	_____
PM / SALES	:	_____
DATE	:	_____
CUSTOMER SIGNATURE & Date	:	_____

- (1) TXC requires one copy returned with signature and title of authorized individual that signifies acceptance of the attached specifications.
- (2) Orders received and accepted by TXC after return of signed copy of specification will be produced per these specifications.
- (3) Any changes to these specifications must be agreed upon by both parties and new revision of the Product Specification Sheet will be issued.
- (4) Any issuance of purchase order prior to consigning back the Approval page of "Specification Sheets" from customers will be regarded as the agreement on the contents of these specifications.

Attachment: Product Specification Sheet

- 1
- 2
- 3
- 4
- 5

RoHS Compliant



TXC CORPORATION

4F, NO. 16, Sec. 2 Chung Yang S Rd., Peitou, Taipei, Taiwan.

TEL : 886-2-2894-1202 , 886-2-2895-2201 FAX : 886-2-2894-1206 , 886-2-2895-6207

www.txccorp.com

PRODUCT SPECIFICATION SHEET



CN: 1307000713

PRODUCT TYPE : HC-49/S SMD

NOMINAL FREQ. : 27.000000MHz

TXC P/N : AT27000001

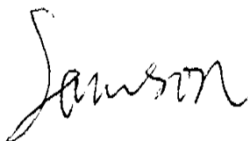
REVISION : A2

PE/RD	QA	MFG
		
12-Oct-11	12-Oct-11	12-Oct-11

NOTE:

- (1)Lead Free Products are "Directive 2002/95/EC of The European Parliament of 27 January 2003 on the restriction of the use of certain hazardous substances (RoHS) in electrical and electronic equipment" Compliant (Attachment: SGS Test Report).
- (2)Revision "Sx" is for engineering samples only. PE/RD's approval required.
- (3)Revision "Ax" is production ready. PE, QA and MFG's approval required

RoHS Compliant



Spec Sheet Contents

No.	Content	Page
1	ELECTRICAL SPECIFICATIONS	P.3
2	FACTORY LOCATION	P.3
3	DIMENSIONS	P.4
4	SUGGESTED REFLOW PROFILE& MANUAL SOLDER CONDITION	P.4
5	MARKING	P.5
6	STRUCTURE ILLUSTRATION	P.6
7	EMBOSS CARRIER TAPE & REEL	P.7
8	PACKING	P.7
9	RELIABILITY SPECIFICATIONS	P.8~9

ELECTRICAL SPECIFICATIONS
Standard atmospheric conditions

Unless otherwise specified, the standard range of atmospheric conditions for making measurement and tests are as follow:

Ambient temperature : 25+/-5°C
 Relative humidity : 40%~70%

If there is any doubt about the results, measurement shall be made within the following limits:

Ambient temperature : 25+/-1°C
 Relative humidity : 40%~70%

Measure equipment

SAUNDERS 250A/250B CRYSTAL IMPEDANCE METER.

Crystal cutting type

The crystal is using AT CUT (thickness shear mode).

Unit Weight:

0.58±0.050 g/pcs

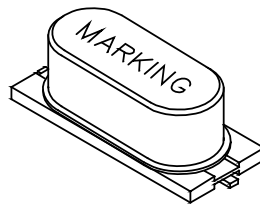

please refer to marking code page

	Parameters	SYM.	Electrical Spec.				Notes
			MIN	TYPE	MAX	UNITS	
1	Nominal Frequency	FL	27.000000			MHz	-
2	Oscillation Mode	-	Fundamental			-	-
3	Load Capacitance	CL	16			pF	-
4	Frequency Tolerance	-	±30			ppm	at 25 °C ± 3 °C
5	Frequency Stability	-	±50			ppm	Over Operating Temp. Range (Reference 25°C)
6	Operating Temperature	-	-40	~	85	°C	-
7	Aging	-	±5			ppm	1st Year
8	Drive Level	DL	-	-	100	uW	-
9	Effective Resistance Rr	Rr	-	-	40	Ω	-
10	Shunt Capacitance C0	C0	-	-	-	pF	-
11	Insulation Resistance	-	500	-	-	MΩ	at DC 100V
12	Storage Temperature Range	-	-55	~	125	°C	-

■ FACTORY LOCATION

TXC (NINGBO) CORPORATION
 NO.189 Huang Shan West Road, Beilun District,
 Ningbo Zhejiang China

DIMENSIONS

UNIT:mm

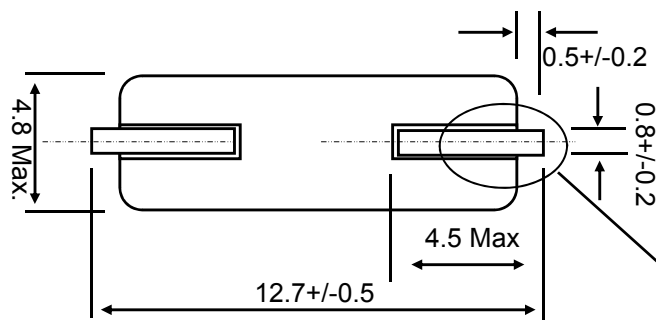
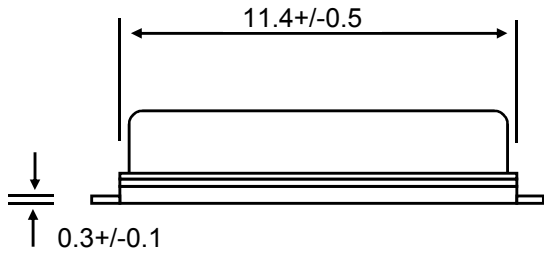

Solder Coating
 (Sn-Ag-Cu Pb Free Coating)

Suggested Layout

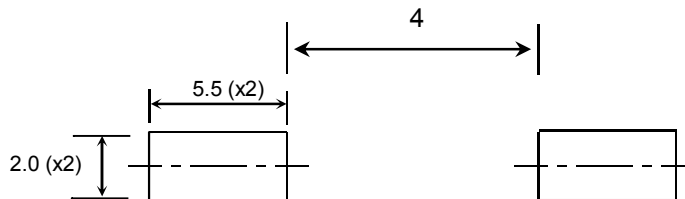

SUGGESTED REFLOW PROFILE

Solder melting point : $220 \pm 10 \text{ }^\circ\text{C}$, 60 sec. Min.
 Peak Temperature: $260 \pm 5 \text{ }^\circ\text{C}$, 10 sec. Max.

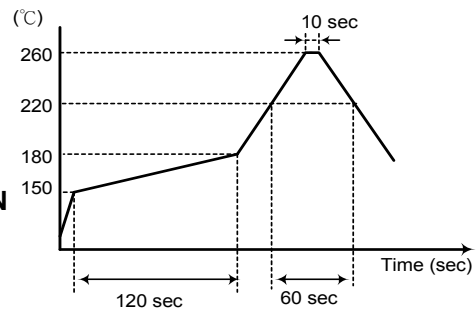

SUGGESTED MANUAL SOLDER CONDITION

Temperature: $350 \pm 10 \text{ }^\circ\text{C}$
 Time: 3 sec.
 Re-solder times: twice

MARKING

Marking For Pb Free Parts :

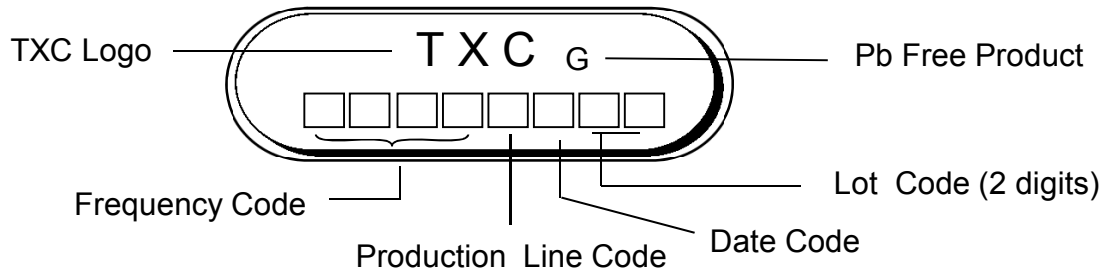

Date Code:

YEAR					MONTH											
					JAN	FEB	MAR	APR	MAY	JUN	JUL	AUG	SEP	OCT	NOV	DEC
2001	2005	2009	2013	2017	A	B	C	D	E	F	G	H	J	K	L	M
2002	2006	2010	2014	2018	N	P	Q	R	S	T	U	V	W	X	Y	Z
2003	2007	2011	2015	2019	a	b	c	d	e	f	g	h	j	k	l	m
2004	2008	2012	2016	2020	n	p	q	r	s	t	u	v	w	x	y	z

*This date code will be cycled every four years.

For example : Marking

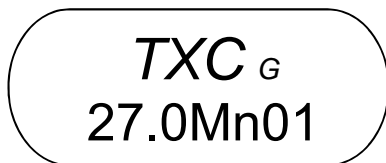

→
Introduction : Pb Free Product
49S/SMD 27.000 MHz
Made in NGB 2008/JAN 01Lot

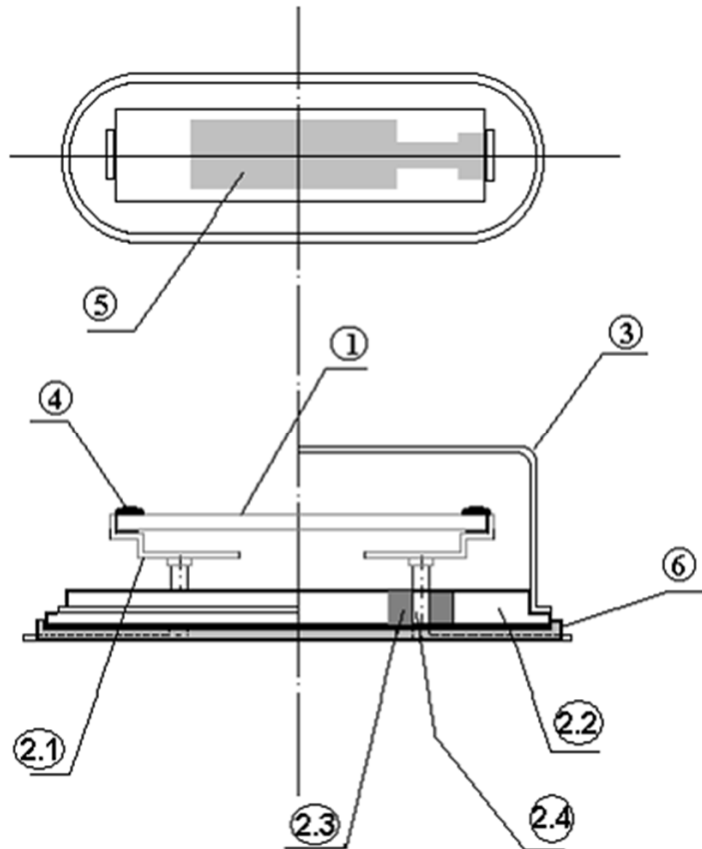
■ STRUCTURE ILLUSTRATION

NO	COMPONENTS	MATERIALS	FINISH/SPECIFICATIONS
1	CRYSTAL BLANK	QUARTZ(SiO ₂)	-
2	CRYSTAL BASE	SUPPORTER	Nickel Silver(Cu/Zn/Ni)
		HOLDER	SPCC(Fe)
		GLASS	GLASS
		LEAD	Kovar (Fe/Co/Ni)
3	CRYSTAL COVER	Nickel Silver(Cu/Zn/Ni)	Ni Plated
4	CONDUCTIVE ADHESIVE	Resin + Ag	-
5	ELECTRODE	Noble Metal	-
6	INSULATION PAD	PPS	-

(A) Tape and reel configuration:(Unit : mm)

(a) Emboss taping configuration. (per EIA-481-2)

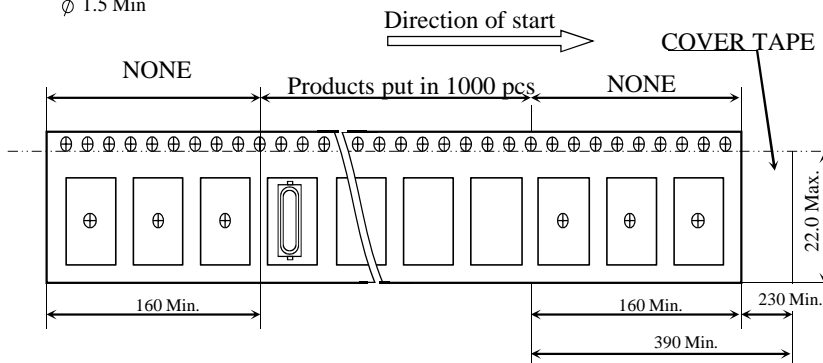
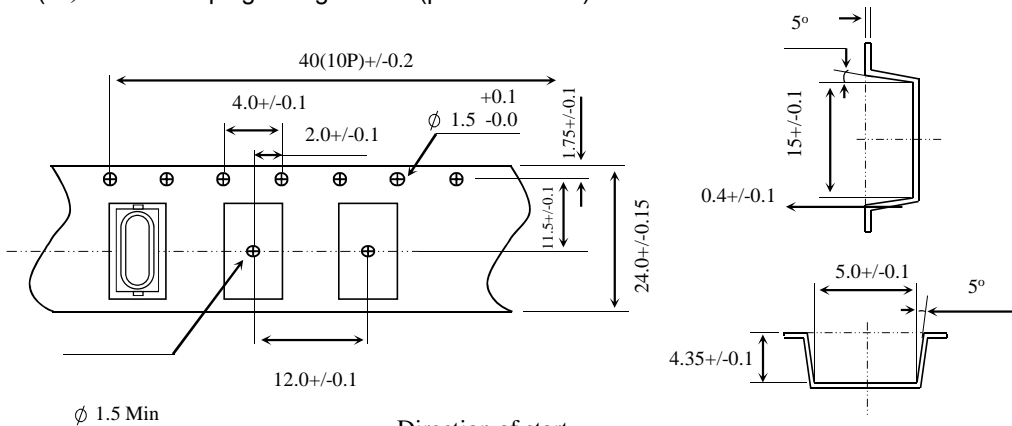

(b) Reel configuration.

(B) Packing & Label :(Unit : mm)

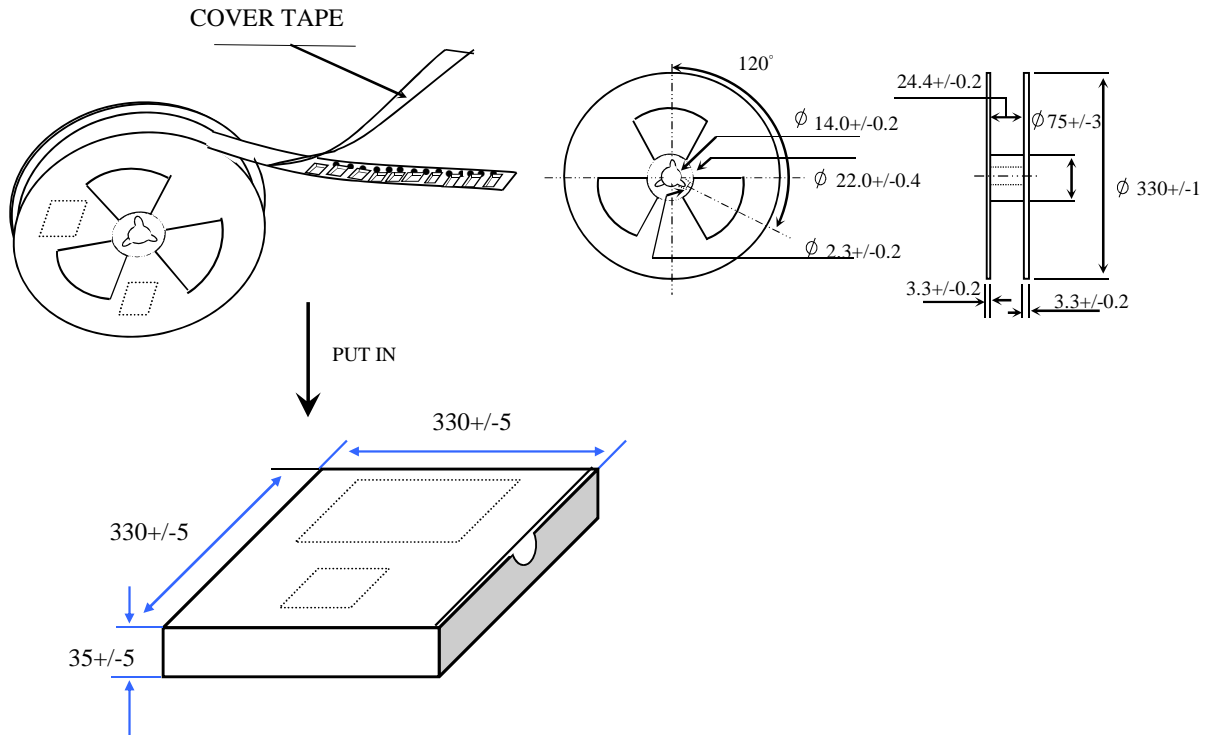

[STORAGE]

1. The storage time to be 1 year maximum.
2. Don't be caught in the rain.
3. The storage environment shall be $5^{\circ}\text{C} \sim 40^{\circ}\text{C}$ temperature and 30% ~ 75%RH humidity and free from the sun shine.
4. If customers have special requirements, we can paste labels according to it.

■ RELIABILITY SPECIFICATIONS (AEC-Q200 Compliant)
1.Mechanical Endurance

No.	Test Item	Test Methods	Test Criteria
1.1	Mechanical Shock	1000 G , 0.5 m Sec. , 3 times for all 3 directions.	B C
1.2	Vibration	Frequency range 10 ~ 2000 Hz Acceleration 20G Sweep time 20 minute Pencil axes each test time 4 hours (Total test time 12 hours)	B C
1.3	Terminal Strength	17.7N force for 60sec +/-1sec.	F
1.4	Board Flex	Duration time:60 Sec Minimum,Deviation:3mm	B C
1.5	Solderability	Temperature 245 °C +/- 5°C Immersing depth 0.5 mm minimum Immersion time 5 +/- 0.5 seconds Flux Rosin resin methyl alcohol solvent (1 : 4)	E

2.Environmental Endurance

No.	Test Item	Test Methods	SPEC
2.1	Resistance To Soldering Heat	Test temperature 260 +/- 5 °C Test time 10 +/- 1 sec.	ACD
2.2	High Temp. Storage	+ 85°C ± 3 °C for 1000 ± 12 Hrs	ACD
2.3	Low Temp. Storage	- 40 °C ± 3 °C for 1000 ± 12 Hrs	ACD
2.4	Temperature cycle	-40°C~85°C,for 1000 cycles. 	ACD
2.5	Operational Life	1000 hrs @ 85± 3°C. Rated VDD applied with 1 MΩ.	ACD
2.6	High Temp&Humidity	85°C ± 3°C , RH 85% , 1000 Hrs	ACD

RELIABILITY SPECIFICATIONS

Specifications	
A	Frequency change: Within ± 20 ppm or in customer's specification.
B	Frequency change: Within ± 10 ppm or in customer's specification.
C	Equivalent series resistance(E.S.R) change: Within $\pm 15\%$ or 10Ω (larger value).
D	After conditioning , quartz crystal units shall be subjected to standard atmospheric conditions for 24 hour, and measured.
E	Minimum 95% of immersed terminal shall be covered with new uniform solder.
F	No damage on specimen

Measurement condition

Measurements are carried out with Network-analyzer(S&A 250B or equivalent).

X-ON Electronics

Largest Supplier of Electrical and Electronic Components

Click to view similar products for [Crystals category](#):

Click to view products by [TXC Corporation manufacturer](#):

Other Similar products are found below :

[CS325S24000000ABJT](#) [718-13.2-1](#) [MC405 32.0000K-R3:PURE SN](#) [FC-135R 32.7680KF-A3](#) [7A-40.000MAAE-T](#) [7B-27.000MBBK-T](#)
[FL2000085](#) [9B-15.360MBBK-B](#) [9C-7.680MBBK-T](#) [ASH7K-32.768KHZ](#) [AT-41.600MAGQ-T](#) [BTD1062E05A-513](#) [LFX TAL066198Cutt](#)
[9C-14.31818MBBK-T](#) [FA-238 50.0000MB30X-K3](#) [FC-12M 32.7680KA-AC3](#) [SSPT7F-9PF20-R](#) [FX325BS-38.88EEM1201](#)
[LFX TAL065253Cutt](#) [LFX TAL066431Cutt](#) [XT9S20ANA14M7456](#) [XT9SNLANA16M](#) [646G-24-2](#) [7A-24.576MBBK-T](#) [7B-30.000MBBK-T](#)
[WX26-32.768K-6PF](#) [9B-14.31818MBBK-B](#) [CD1AM](#) [7B-25.000MAAE-T](#) [7A-14.31818MBBK-T](#) [6504-202-1501](#) [6526-202-1501](#) [FA-118T](#)
[27.1200MB50P-K0](#) [FC-135R 32.7680KA-A3](#) [ABM12-104-37.400MHZT](#) [ABLS-10.000MHZ-D3W-T](#) [BTJ112E01E-513](#) [BTJ722K01C-7067](#)
[BTL-20-513](#) [TSX-3225 24.0000MF15X-AC](#) [TSX-3225 16.0000MF18X-AC](#) [BTJ120E02C](#) [BTL-12-513](#) [7A-10.000MBBK-T](#) [7A-](#)
[11.0592MBBK-T](#) [ABM12-103-24.000MHZT](#) [CS325S25000000ABJT](#) [ABM3B-25.000MHZ-B2-X-T](#) [FC-135 32.7680KA-A5](#) [FX0800015](#)