

ALUMINUM ELECTROLYTIC CAPACITORS

HE series
Miniature Sized, Low Impedance, High Reliability

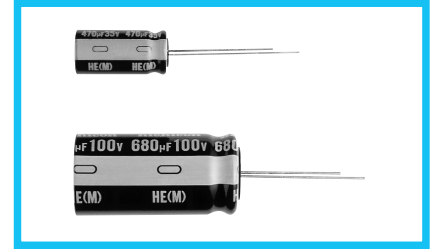

- Low impedance and high reliability withstanding 4000 hours to 10000 hours.
- Compliant to the RoHS directive (2011/65/EU).



Specifications

Item	Performance Characteristics										
Category Temperature Range	-40 to +105°C										
Rated Voltage Range	6.3 to 100V										
Rated Capacitance Range	0.47 to 18000μF										
Capacitance Tolerance	±20% at 120Hz, 20°C										
Leakage Current	After 2 minutes' application of rated voltage at 20°C, leakage current is not more than 0.01CV or 3 (μA), whichever is greater.										
Tangent of loss angle (tan δ)	Rated voltage (V)	6.3	10	16	25	35	50	63	100	120Hz 20°C	
	tan δ (MAX.)	0.22	0.19	0.16	0.14	0.12	0.10	0.09	0.08		
For capacitance of more than 1000μF, add 0.02 for every increase of 1000μF.											
Stability at Low Temperature	Rated voltage (V)	6.3	10	16	25	35	50	63	100	120Hz	
	Impedance ratio ZT / Z20 (MAX.)	Z-25°C / Z+20°C	4	3	2	2	2	2	2		2
		Z-40°C / Z+20°C	8	6	4	3	3	3	3	3	
Endurance	The following specifications shall be met when the capacitors are restored to 20°C after D.C. bias plus rated ripple current is applied at 105°C, the peak voltage shall not exceed the rated voltage.										
	Case size		φD ≤ 6.3	φD = 8, 10	φD ≥ 12.5						
	Rated voltage (V)	6.3 to 10WV	4000 hours	6000 hours	8000 hours						
		16 to 100WV	5000 hours	7000 hours	10000 hours						
	Capacitance change	Within ±25% of the initial capacitance value									
	tan δ	200% or less than the initial specified value									
Leakage current	Less than or equal to the initial specified value										
Marking	Printed with white color letter on black sleeve.										

Radial Lead Type

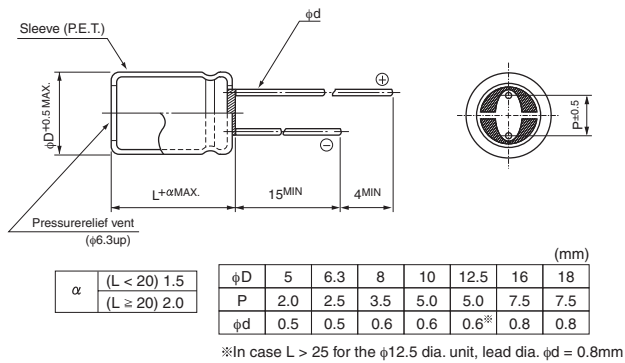

• Please refer to page 20 about the end seal configuration.

Frequency coefficient of rated ripple current

Cap. (μF)	50Hz	120Hz	300Hz	1kHz	10kHz or more
0.47 to 33	0.45	0.55	0.70	0.90	1.00
39 to 330	0.60	0.70	0.85	0.95	1.00
390 to 1000	0.65	0.75	0.90	0.98	1.00
1200 to 18000	0.75	0.80	0.95	1.00	1.00

Type numbering system (Example : 10V 1000μF)

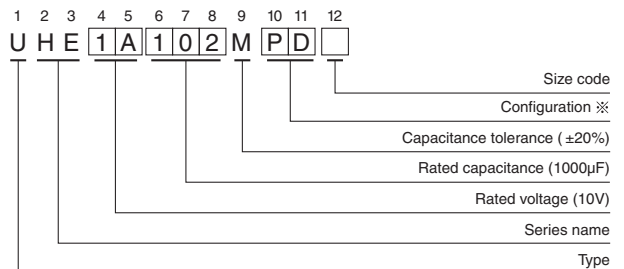

※ Configuration

φ D	Pb-free leadwire Pb-free PET sleeve
5	DD
6.3	ED
8 - 10	PD
12.5 to 18	HD

Please refer to page 20, 21, 22 about the formed or taped product spec.
Please refer to page 4 for the minimum order quantity.

● Dimension table in next page.



Standard Ratings

V (Code) Item Cap.(μF) Code		6.3 (0J)				10 (1A)			
		Case size φD × L (mm)	Impedance (Ω) MAX.		Rated ripple (mArms) 105°C / 100kHz	Case size φD × L (mm)	Impedance (Ω) MAX.		Rated ripple (mArms) 105°C / 100kHz
			20°C / 100kHz	-10°C / 100kHz			20°C / 100kHz	-10°C / 100kHz	
100	101					5 × 11	0.58	2.3	210
150	151	5 × 11	0.58	2.3	210				
220	221					6.3 × 11	0.22	0.87	340
330	331	6.3 × 11	0.22	0.87	340				
470	471					8 × 11.5	0.13	0.52	640
680	681	8 × 11.5	0.13	0.52	640	8 × 15	0.087	0.35	840
		▲ 10 × 12.5	0.080	0.32	865		0.080	0.32	865
820	821	10 × 12.5	0.080	0.32	865				
1000	102	8 × 15	0.087	0.35	840	8 × 20	0.069	0.27	1050
		▲ 10 × 16	0.060	0.24	1210		0.060	0.24	1210
1200	122	8 × 20	0.069	0.27	1050	10 × 20	0.046	0.18	1400
		▲ 10 × 16	0.060	0.24	1210				
1500	152	10 × 20	0.046	0.18	1400	10 × 25	0.042	0.17	1650
1800	182	12.5 × 15	0.049	0.16	1450	▲ 12.5 × 15	0.049	0.16	1450
2200	222	10 × 25	0.042	0.17	1650	10 × 31.5	0.031	0.12	1910
						▲ 12.5 × 20	0.035	0.12	1900
						● 16 × 15	0.042	0.12	1940
2700	272	▲ 10 × 31.5	0.031	0.12	1910	18 × 15	0.043	0.11	2210
		16 × 15	0.042	0.12	1940				
3300	332	12.5 × 20	0.035	0.12	1900	12.5 × 25	0.027	0.089	2230
3900	392	12.5 × 25	0.027	0.089	2230	12.5 × 31.5	0.024	0.078	2650
		▲ 18 × 15	0.043	0.11	2210	▲ 16 × 20	0.027	0.078	2530
4700	472	12.5 × 31.5	0.024	0.078	2650	12.5 × 35.5	0.020	0.065	2880
5600	562	12.5 × 35.5	0.020	0.065	2880	12.5 × 40	0.017	0.056	3350
		▲ 16 × 20	0.027	0.078	2530	▲ 16 × 25	0.021	0.060	2930
						● 18 × 20	0.026	0.067	2860
6800	682	12.5 × 40	0.017	0.056	3350	16 × 31.5	0.017	0.050	3450
		▲ 16 × 25	0.021	0.060	2930				
		● 18 × 20	0.026	0.067	2860				
8200	822	16 × 31.5	0.017	0.050	3450	16 × 35.5	0.015	0.044	3610
						▲ 18 × 31.5	0.015	0.040	4170
10000	103	16 × 35.5	0.015	0.044	3610	16 × 40	0.013	0.038	4080
		▲ 18 × 25	0.019	0.049	3140	▲ 18 × 35.5	0.014	0.038	4220
12000	123	16 × 40	0.013	0.038	4080	18 × 40	0.012	0.032	4280
		▲ 18 × 31.5	0.015	0.040	4170				
15000	153	18 × 35.5	0.014	0.038	4220				
18000	183	18 × 40	0.012	0.032	4280				

▲ : In this case, [6] will be put at 12th digit of type numbering system.
● : In this case, [3] will be put at 12th digit of type numbering system.



Standard Ratings

Cap.(μ F)	V (Code) Item Code	16 (1C)				25 (1E)			
		Case size ϕ D \times L (mm)	Impedance (Ω) MAX.		Rated ripple (mArms) 105°C / 100kHz	Case size ϕ D \times L (mm)	Impedance (Ω) MAX.		Rated ripple (mArms) 105°C / 100kHz
			20°C / 100kHz	-10°C / 100kHz			20°C / 100kHz	-10°C / 100kHz	
47	470					5 \times 11	0.58	2.3	210
56	560	5 \times 11	0.58	2.3	210				
100	101					6.3 \times 11	0.22	0.87	340
120	121	6.3 \times 11	0.22	0.87	340				
220	221					8 \times 11.5	0.13	0.52	640
330	331	8 \times 11.5	0.13	0.52	640	8 \times 15	0.087	0.35	840
		▲ 10 \times 12.5	0.080	0.32	865	▲ 10 \times 16	0.069	0.27	1050
470	471	8 \times 15	0.087	0.35	840	8 \times 20	0.069	0.27	1050
		▲ 10 \times 12.5	0.080	0.32	865	▲ 10 \times 16	0.069	0.27	1050
680	681	8 \times 20	0.069	0.27	1050	10 \times 20	0.046	0.18	1400
		▲ 10 \times 16	0.060	0.24	1210	▲ 12.5 \times 15	0.049	0.16	1450
820	821					10 \times 25	0.042	0.17	1650
1000	102	10 \times 20	0.046	0.18	1400	10 \times 31.5	0.031	0.12	1910
		▲ 12.5 \times 15	0.049	0.16	1450	▲ 12.5 \times 20	0.035	0.12	1900
						● 16 \times 15	0.042	0.12	1940
1200	122	10 \times 25	0.042	0.17	1650	18 \times 15	0.043	0.11	2210
1500	152	10 \times 31.5	0.031	0.12	1910	12.5 \times 25	0.027	0.089	2230
		▲ 12.5 \times 20	0.035	0.12	1900				
		● 16 \times 15	0.042	0.12	1940				
1800	182					12.5 \times 31.5	0.024	0.078	2650
						▲ 16 \times 20	0.027	0.078	2530
2200	222	12.5 \times 25	0.027	0.089	2230	12.5 \times 35.5	0.020	0.065	2880
		▲ 18 \times 15	0.043	0.11	2210	▲ 18 \times 20	0.026	0.067	2860
2700	272	12.5 \times 31.5	0.024	0.078	2650	12.5 \times 40	0.017	0.056	3350
		▲ 16 \times 20	0.027	0.078	2530	▲ 16 \times 25	0.021	0.060	2930
3300	332	12.5 \times 35.5	0.020	0.065	2880	16 \times 31.5	0.017	0.050	3450
						▲ 18 \times 25	0.019	0.049	3140
3900	392	12.5 \times 40	0.017	0.056	3350	16 \times 35.5	0.015	0.044	3610
		▲ 16 \times 25	0.021	0.060	2930				
		● 16 \times 20	0.026	0.067	2860				
4700	472	16 \times 31.5	0.017	0.050	3450	16 \times 40	0.013	0.038	4080
		▲ 18 \times 25	0.019	0.049	3140	▲ 18 \times 35.5	0.014	0.038	4220
5600	562	16 \times 35.5	0.015	0.044	3610	18 \times 40	0.012	0.032	4280
		▲ 18 \times 31.5	0.015	0.040	4170				
6800	682	16 \times 40	0.013	0.038	4080				
8200	822	18 \times 35.5	0.014	0.038	4220				
10000	103	18 \times 40	0.012	0.032	4280				

▲ : In this case, [6] will be put at 12th digit of type numbering system.
 ● : In this case, [3] will be put at 12th digit of type numbering system.



Standard Ratings

V (Code) Item Cap. (μF) Code		35 (1V)				50 (1H)			
		Case size φD × L (mm)	Impedance (Ω) MAX.		Rated ripple (mArms) 105°C / 100kHz	Case size φD × L (mm)	Impedance (Ω) MAX.		Rated ripple (mArms) 105°C / 100kHz
			20°C / 100kHz	-10°C / 100kHz			20°C / 100kHz	-10°C / 100kHz	
0.47	R47					5 × 11	5.5	22	17
1	010					5 × 11	4	16	30
2.2	2R2					5 × 11	2.5	10	43
3.3	3R3					5 × 11	2.2	8.8	53
4.7	4R7					5 × 11	1.9	7.6	88
10	100					5 × 11	1.5	6	100
22	220					5 × 11	0.70	2.8	180
33	330	5 × 11	0.58	2.3	210	6.3 × 11	0.30	1.2	295
47	470	6.3 × 11	0.22	0.87	250	6.3 × 11	0.30	1.2	295
56	560	6.3 × 11	0.22	0.87	340	6.3 × 11	0.30	1.2	295
100	101	8 × 11.5	0.13	0.52	640	8 × 11.5	0.17	0.68	555
120	121					8 × 15	0.12	0.48	730
150	151	8 × 11.5	0.13	0.52	640	10 × 12.5	0.12	0.48	760
180	181					8 × 20	0.091	0.36	910
220	221	8 × 15	0.087	0.35	840	10 × 16	0.084	0.34	1050
		▲ 10 × 12.5	0.080	0.32	865				
270	271	8 × 20	0.069	0.27	1050	10 × 20	0.060	0.24	1220
		▲ 12.5 × 15				▲ 12.5 × 15	0.061	0.20	1260
330	331	10 × 16	0.060	0.24	1210	10 × 25	0.055	0.22	1440
						▲ 10 × 20	0.060	0.24	1220
470	471	10 × 20	0.046	0.18	1400	10 × 31.5	0.043	0.17	1690
		▲ 12.5 × 15	0.049	0.16	1450	▲ 12.5 × 20	0.045	0.15	1660
						● 16 × 15	0.055	0.17	1690
560	561	10 × 25	0.042	0.17	1650	12.5 × 25	0.034	0.11	1950
						▲ 18 × 15	0.054	0.15	1930
680	681	10 × 31.5	0.031	0.12	1910	12.5 × 31.5	0.030	0.10	2310
		▲ 12.5 × 20	0.035	0.12	1900				
		● 16 × 15	0.042	0.12	1940				
820	821					12.5 × 35.5	0.025	0.083	2510
						▲ 16 × 20	0.034	0.10	2210
1000	102	12.5 × 25	0.027	0.089	2230	12.5 × 40	0.021	0.069	2920
		▲ 18 × 15	0.043	0.11	2210	▲ 16 × 25	0.025	0.075	2555
						● 18 × 20	0.036	0.097	2490
1200	122	12.5 × 31.5	0.024	0.078	2650	16 × 31.5	0.022	0.066	3010
		▲ 16 × 20	0.027	0.078	2530	▲ 18 × 25	0.026	0.070	2740
1500	152	12.5 × 35.5	0.020	0.065	2880	16 × 35.5	0.019	0.057	3150
1800	182	12.5 × 40	0.017	0.056	3350	16 × 40	0.016	0.048	3710
		▲ 16 × 25	0.021	0.060	2930				
		● 18 × 20	0.026	0.067	2860				
2200	222	16 × 31.5	0.017	0.050	3450	▲ 18 × 35.5	0.017	0.046	3680
		▲ 18 × 25	0.019	0.049	3140				
2700	272	16 × 35.5	0.015	0.044	3610	18 × 40	0.014	0.038	3800
		▲ 18 × 31.5	0.015	0.040	4170				
3300	332	16 × 40	0.013	0.038	4080				
		▲ 18 × 35.5	0.014	0.038	4220				
3900	392	18 × 40	0.012	0.032	4280				

▲ : In this case, [6] will be put at 12th digit of type numbering system.

● : In this case, [3] will be put at 12th digit of type numbering system.

Standard Ratings

V (Code)		63 (1J)				100 (2A)			
Cap. (μF)	Item Code	Case size φD × L (mm)	Impedance (Ω) MAX.		Rated ripple (mArms) 105°C / 100kHz	Case size φD × L (mm)	Impedance (Ω) MAX.		Rated ripple (mArms) 105°C / 100kHz
			20°C / 100kHz	-10°C / 100kHz			20°C / 100kHz	-10°C / 100kHz	
6.8	6R8					5 × 11	2.3	9.3	62
15	150	5 × 11	2.3	9.3	62	6.3 × 11	1.2	5.0	126
27	270					8 × 11.5	0.63	2.8	260
33	330	6.3 × 11	1.2	5.0	126				
39	390					8 × 15	0.45	2.1	335
47	470	8 × 11.5	0.63	2.8	260	10 × 12.5	0.43	1.8	325
56	560	8 × 11.5	0.63	2.8	260	8 × 20	0.33	1.6	408
68	680					10 × 16	0.31	1.5	400
82	820	8 × 15	0.45	2.1	335	10 × 20	0.21	0.94	518
		▲ 10 × 12.5	0.43	1.8	325	▲ 12.5 × 15	0.23	1.1	527
100	101					10 × 25	0.20	0.84	595
						▲ 12.5 × 20	0.20	0.84	740
120	121	8 × 20	0.33	1.6	408	10 × 31.5	0.15	0.71	740
		▲ 10 × 16	0.31	1.5	400	▲ 12.5 × 20	0.16	0.64	765
150	151					16 × 15	0.14	0.66	895
180	181	10 × 20	0.21	0.94	518	12.5 × 25	0.12	0.45	875
		▲ 12.5 × 15	0.23	1.1	527	▲ 18 × 15	0.12	0.50	1030
220	221	10 × 25	0.20	0.84	595	12.5 × 31.5	0.10	0.42	1010
						▲ 16 × 20	0.091	0.38	1130
270	271	10 × 31.5	0.15	0.71	740	12.5 × 35.5	0.083	0.35	1140
		▲ 12.5 × 20	0.16	0.64	765				
		● 16 × 15	0.14	0.66	895	▲ 16 × 25	0.073	0.27	1350
330	331	12.5 × 25	0.12	0.45	875	12.5 × 40	0.071	0.30	1280
						▲ 18 × 20	0.080	0.30	1300
390	391	18 × 15	0.12	0.50	1030	16 × 31.5	0.054	0.20	1650
						▲ 18 × 25	0.057	0.21	1560
470	471	12.5 × 31.5	0.10	0.42	1010	16 × 35.5	0.045	0.17	1900
		▲ 16 × 20	0.091	0.38	1130	▲ 18 × 31.5	0.047	0.17	1720
560	561	12.5 × 35.5	0.083	0.35	1140	16 × 40	0.040	0.15	2130
		▲ 16 × 25	0.073	0.27	1350				
680	681	12.5 × 40	0.071	0.30	1280	18 × 35.5	0.040	0.15	1890
		▲ 18 × 20	0.080	0.30	1300				
820	821	16 × 31.5	0.054	0.20	1650	18 × 40	0.036	0.13	2470
		▲ 18 × 25	0.057	0.21	1560				
1000	102	16 × 35.5	0.045	0.17	1900				
		▲ 18 × 31.5	0.047	0.17	1720				
1200	122	16 × 40	0.040	0.15	2130				
		▲ 18 × 35.5	0.040	0.15	1890				
1500	152	18 × 40	0.036	0.13	2470				

▲ : In this case, 6 will be put at 12th digit of type numbering system.
 ● : In this case, 3 will be put at 12th digit of type numbering system.

X-ON Electronics

Largest Supplier of Electrical and Electronic Components

Click to view similar products for [Aluminium Electrolytic Capacitors - Axial Leaded](#) category:

Click to view products by [Nichicon](#) manufacturer:

Other Similar products are found below :

[TPC1V102MCH](#) [EGT108M1VI20RRS0P](#) [EGT687M1CF16RRSHP](#) [PKCE61C102MF](#) [RL0J223MM400A00CV0](#) [EGT477M1EF12RRSNQ](#)
[NFA-450VB68-M-18*25](#) [TDC-450V330-35*30](#) [EGD2GM4R7F12OT](#) [RGA470M2ABK-0811G](#) [EKXJ451EC3470ML25S](#)
[35PX220MEFC8X11.5](#) [450MXG220MEFCSN30X30](#) [100PX220MEFC12.5X20](#) [25YXJ220M6.3X11](#) [601D108G050JL2](#) [MAL202124471E3](#)
[TE1100](#) [MAL202128331E3](#) [TN470K1HBK-1017P](#) [PEG124KF347CQL1](#) [TE1509-E3](#) [MAL213826221E3](#) [686TTA016M](#) [WBR16-250A](#)
[MAL202129108E3](#) [AXLH472P025EL](#) [AXLH681P063EH](#) [TVAN1200](#) [TVA1508-E3](#) [30D405G100BA5A](#) [PEG124MA2100QL1](#)
[MAL202129221E3](#) [MAL213828471E3](#) [MAL202128108E3](#) [HHT222P030HJ0](#) [MAL202129109E3](#) [MAL212028221E3](#) [PEG124PD247VQL1](#)
[30D396M100DD2A](#) [PEG124MC310AQT1](#) [MAL202129479E3](#) [TEA100M2ABK-0613P](#) [AXLH901P063EL](#) [MAL211890503E3](#)
[600D256G060DD4](#) [B41693A8477Q007](#) [AXLH222P025ED](#) [MAL202128229E3](#) [AXLH152P040ED](#)