



## ZGY133/T9(PLT)

### Photo-link Light Transmitter Unit

#### Descriptions

The opto-electrical component is assembled with a 660nm AlGaInP LED and a driver IC. It transforms the electrical signal to optical signal and be transmitted by 1mm diameter plastic optical fiber.

The component is operated at +3~+5V and has good performance at low dissipation current, steady light output and efficient light coupling.

#### Features

- High speed signal transmission (16Mbps NRZ Signal)
- TTL interface compatible
- +3~+5V single power source
- The product itself will remain within RoHS compliant version.

#### Applications

- Digital audio equipment
- CD player
- DVD player

#### Device Selection Guide

Chip		Operating Voltage (Vcc)	Dissipation Current (mA)		Fiber Coupling Light Output (dBm)		
Material	$\lambda$ (nm)		Typ.	Max.	Min.	Typ.	Max.
AlGaInP	660	+3.0~5.0	5.5	10	-21	---	-15



## Package Dimensions

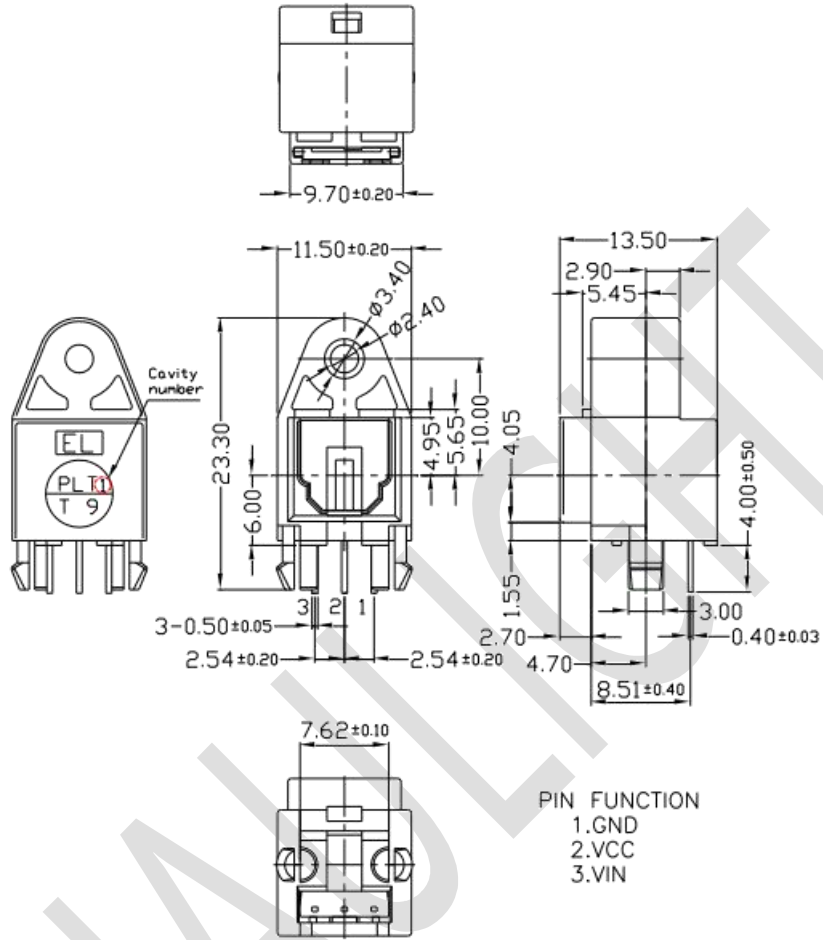

### Notes:

- 1.All dimensions are in millimeters.
- 2.General Tolerance :±0.3mm

### Using Method

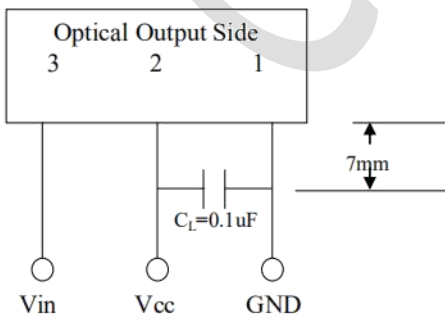

### PCB Layout for Electrical Circuit

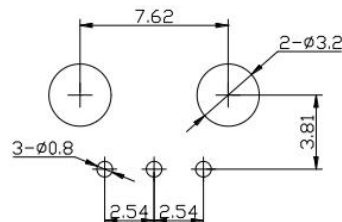

- Notes:
- 1.unit:mm
  - 2.Dimension Tolerance:±0.25mm
  - 3.Substrate Thickness:1.6mm



## Absolute Maximum Ratings( Ta = 25°C)

Parameter	Symbol	Rating	Unit
Supply Voltage	Vcc	-0.5 to 7	V
DC Input Voltage	Vin	-0.5 to Vcc+0.5	V
Storage Temperature	Tstg	-40 to 85	°C
Operating Temperature	Topr	-40 to 85	°C
Soldering Temperature	Tsol	260*	°C
Human Body Model ESD	HBM	3K	V
Machine Model ESD	MM	300	V

\* Soldering time ≤ 10 seconds.

## Recommended Operating Conditions

Parameter	Symbol	Conditions	MIN.	TYP.	MAX.	Unit
Supply Voltage	Vcc	-	2.7	3.0	5.50	V

## Electro-Optical Characteristics (Ta=25°C, Vcc=5.0V, 16Mbps)

Parameter	Symbol	Conditions	MIN.	TYP.	MAX.	Unit
Peak Emission Wavelength	$\lambda_p$		640	660	680	nm
Transmission Rate		NRZ Signal	DC	-	16	Mbps
Fiber Coupling Output Power	Pf	* Measuring Method 1	-21	-	-15	dBm
Dissipation Current	Icc	* Measuring Method 1	3	-	10	mA
High Level Input Voltage	Vih		2	-	-	V
Low Level Input Voltage	Vil		-	-	0.8	V
Rise Time	Tr	[1]; *2 NRZ Code VFLED = 2.0V	-	15	20	ns
Fall Time	Tf		-	15	20	ns
Low to High Delay Time	tpLH	* Measuring Method 2	-	-	100	ns
High to Low Delay Time	tpHL	* Measuring Method 2	-	-	100	ns
Pulse Width Distortion	$\Delta tw$	* Measuring Method 2	-15	-	15	ns
Jitter	$\Delta tj$	* Measuring Method 2	-	1.5	15	ns

\*Note 1 : All Plastic Optical Fiber (980/1000um)



# CHAU LIGHT Technical Data Sheet

## \*Circuit Layout Notice:

When power is off, it must be cut off together in Vin and Vcc pin.  
 If it only has Vcc power-off, LED will sure to be no output power.

Vcc	Vin	LED Condition
2.7~5.5V	High	ON
2.7~5.5V	Low	OFF
2.7~5.5V	FLOATING	ON
FLOATING	0~Vcc	ON

## Measuring Method

### \*1 Measuring method of optical output coupling fiber and dissipation current

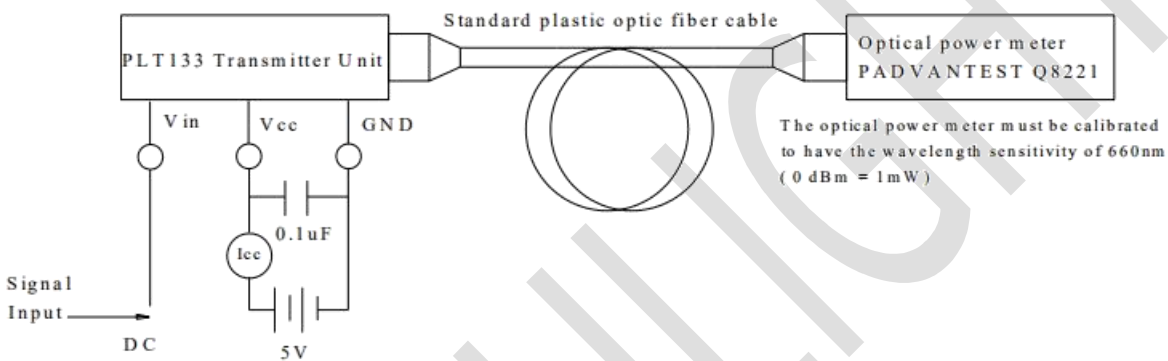

### \*2 Pulse response measuring method

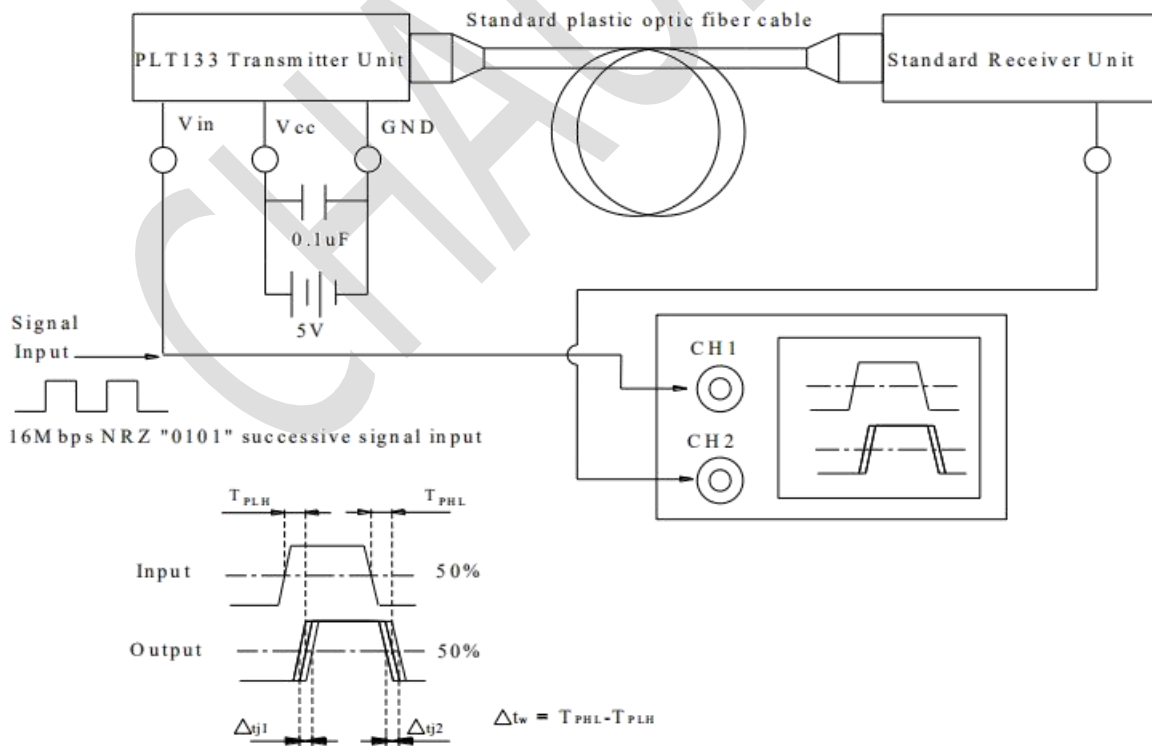



## Packing Quantity Specification

1. 50 pcs/tube
2. 20 tube/Inner box
3. 4 Inner box/Outside box

CHAU LIGHT

## X-ON Electronics

Largest Supplier of Electrical and Electronic Components

*Click to view similar products for [Fiber Optic Transmitters, Receivers, Transceivers](#) category:*

*Click to view products by [Chau Light](#) manufacturer:*

Other Similar products are found below :

[FWLF-1521-7D-47](#) [FWLF-1521-7D-61](#) [HFBR-1532ETZ](#) [HFBR-2541ETZ](#) [HFBR-2602Z](#) [AFBR-0548Z](#) [AFBR-1639Z](#) [AFBR-1539Z](#) [AFBR-2634Z](#) [AFCT-5962ATLZ](#) [FTLX3813M354](#) [HFBR-2531ETZ](#) [STV.2413-574-00262](#) [TRPRG1VA1C000E2G](#) [TORX1952\(6M,F\)](#)  
[TOTX1350\(F\)](#) [TOTX1350\(V,F\)](#) [FTLX3813M349](#) [HFBR-2542ETZ](#) [SCN-1428SC](#) [AFBR-POC406L](#) [HFBR-2506AFZ](#) [FTLX1871M3BNL](#)  
[FWLF-1521-7D-49](#) [HFBR-1542ETZ](#) [FWLF-1519-7D-49](#) [HFBR-2532ETZ](#) [AFBR-1541CZ](#) [TORX1355\(V,F\)](#) [AFBR-1521CZ](#) [LTK-ST11MB](#)  
[TORX1355\(F\)](#) [HFD8003-002/XBA](#) [HFD3020-500-ABA](#) [S6846](#) [SCN-2638SC](#) [FTL410QE4N](#) [SCN-1570SC](#) [SCN-1601SC](#) [SCN-1338SC](#)  
[HFBR-1505CFZ](#) [AFBR-1528CZ](#) [AFBR-1531CZ](#) [HFD3081-108-XBA](#) [HFD8003-500-XBA](#) [SCN-1255SC](#) [SCN-1383SC](#) [1019682](#) [1019683](#)  
[1019705](#)