

## A Highly Integrated USB Audio Single Chip

### DESCRIPTION

The HS-100B is a highly-integrated, crystal-free USB audio single chip solution optimized typically for USB headset, headphone, and dongle (wireless adapter enabled) applications. All necessary analog and digital modules were embedded in the HS-100B, including stereo DAC and earphone driver; mono ADC; microphone pre-amp booster; PLL; regulator; and USB transceiver. Many features of the HS-100B are programmable with jumper pins or external EEPROM. Customers can customize unique USB VID / PID / Product String / Manufacture String and max / min / initial volume settings via an external EEPROM. In addition, the HS-100B supports HID compliant volume control pins such as Playback Mute, Volume Up/Down and a Record Mute pin which interacts with the playback operation LED and record mute LED control pins. The HS-100B also comes with an anti-pop noise circuits design and internal oscillator which can operate without an external crystal oscillator.

### FEATURES

- Compliant with USB 2.0 Full-Speed operation
- Compliant with USB Audio Device class specification v1.0
- Supports USB Suspend/Resume Mode and remote wakeup with volume control pins
- On-chip oscillator that provides reference sources for PLL and embedded USB transceiver
- Jumper pin for Headset Mode (Playback + Recording) and Speaker/Headphone Mode (Playback Only)
- Jumper pin for Mixer Unit enable/disable under Headset Mode
- Jumper pin for Power Mode setting
- USB audio function topology that has 2 Input Terminals, 2 Output Terminals, 1 Mixer Unit, 1 Selector Unit, and 3 Feature Units. (Headset Mode)
- USB audio function topology that has 1 Input Terminal, 1 Output Terminal, and 1 Feature Unit. (Speaker Mode)
- Anti-pop noise design for device plugged and vice-versa.

### BLOCK DIAGRAM

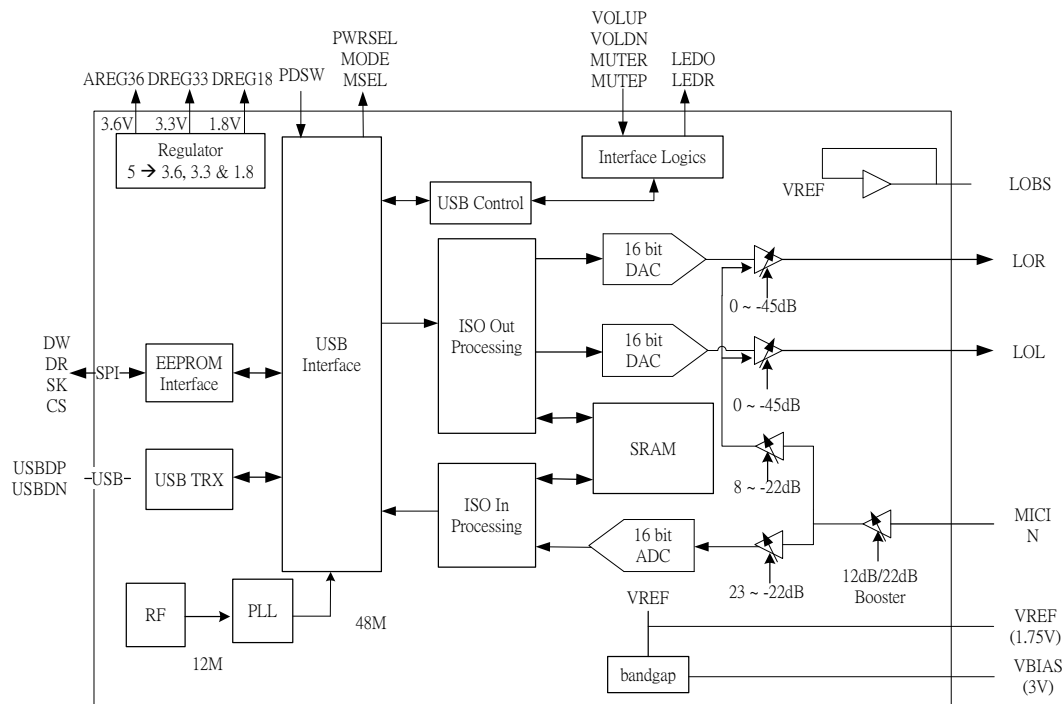

---

**Revision notes**

Revision	Date	Description
1.0	27 Sep 2013	First release

---

## LIST OF CONTENTS

1	Description and Overview .....	4
2	Ordering Information.....	4
3	Features.....	4
4	Pin Descriptions.....	5
	4.1 Pin Assignment.....	5
	4.2 Pin-out Diagram .....	5
	4.3 Pin-out Diagram .....	6
5	USB Topology .....	8
	5.1 Headset Topology .....	8
	5.1.1 Device Descriptor.....	8
	5.1.2 Configuration Descriptor.....	8
	5.2 Speaker Topology.....	9
	5.2.1 Device Descriptor .....	9
	5.2.2 Configuration Descriptor.....	9
6	Function Description .....	10
	6.1 Content Format for EEPROM(93C46) .....	10
	6.1.1 Addressing .....	10
	6.1.2 EEPROM SPI Interface Timing Information .....	11
	6.2 Jumper Pins and Mode Setting .....	13
	6.3 HID Feature and Descriptions .....	13
	6.3.1 HID Interface Descriptor.....	14
	6.3.2 HID Descriptor.....	14
	6.3.3 Interrupt in Endpoint Descriptor .....	14
7	Electrical Characteristics.....	15
	7.1 Absolute Maximum Rating .....	15
	7.2 Operation Conditions .....	15
	7.3 Electrical Parameters.....	16
8	Package Dimensions .....	17
	Reference .....	18

## 1 Description and Overview

The HS-100B is a highly-integrated, crystal-free USB audio single chip solution optimized typically for USB headset, headphone, and dongle (wireless-adapter enabled) applications. All necessary analog and digital modules are embedded in the HS-100B, including stereo DAC and earphone driver; mono ADC; microphone pre-amp booster; PLL; regulator; and USB transceiver. Many features of the HS-100B are programmable with jumper pins or external EEPROM. Customers can customize unique USB VID / PID / Product String / Manufacture String and max / min / initial volume settings via an external EEPROM. In addition, the HS-100B supports HID compliant volume control pins such as Playback Mute, Volume Up/Down and a Record Mute pin which interacts with the playback operation LED and record mute LED control pins. The HS-100B also comes with an anti-pop noise circuits design and internal oscillator which can operate without an external crystal oscillator. With turn-key reference design, customers can easily and quickly deliver the quality USB headset peripherals to the market.

## 2 Ordering Information

Product	Package Marking	Package Type	Transport Media	Storage Temperature
HS-100B	HS-100B	LQFP-48 (7 x 7mm) Green Package	Tray	-45 to 120°C

## 3 Features

- Compliant with USB 2.0 Full-Speed operation
- Compliant with USB Audio Device class specification v1.0
- Supports USB Suspend/Resume Mode and remote wakeup with volume control pins
- On-chip oscillator that provides reference sources for PLL and embedded USB transceiver
- Jumper pin for Headset Mode (Playback + Recording) or Speaker/Headphone Mode (Playback Only)
- Jumper pin for Mixer Unit enable/disable under Headset Mode
- Jumper pin for Power Mode setting
- USB audio function topology that has 2 Input Terminals, 2 Output Terminals, 1 Mixer Unit, 1 Selector Unit, and 3 Feature Units. (Headset Mode)
- USB audio function topology that has 1 Input Terminal, 1 Output Terminal, and 1 Feature Unit. (Speaker Mode)
- Anti-pop noise design for device plugged and vice-versa, while A-A path is off.
- Supports one control endpoint, one Isochronous out endpoint, one Isochronous in endpoint, and one Interrupt in endpoint
- Alternate zero bandwidth setting for releasing playback bandwidth on USB bus when this device is inactive
- Includes Volume up, volume down, and playback mute support USB HID for PC host system SW volume synchronization
- Record Mute pin with a LED Indicator for record mute status
- External EEPROM interface using SPI (Serial Peripheral Interface) for vendor Specific USB VID, PID, Product String, Manufacture String, Serial Number and initial/min/max volume settings
- Isochronous transfer uses Adaptive Mode with internal PLL for synchronization
- 48K/44.1KHz sampling rate for both playback and recording
- Soft Mute function
- Embedded 16bit audio DAC with earphone phone buffer

- Embedded 16bit ADC input with Microphone Boost
- Embedded power on reset block
- Embedded 5V to 3.6V / 3.3V / 1.8 V regulators for single external 5V power
- Industrial standard 48-pin LQFP Package

## 4 Pin Descriptions

### 4.1 Pin Assignment

Pin #	Signal Name	Pin #	Signal Name	Pin #	Signal Name	Pin #	Signal Name
1	DR	13	N.C.	25	AVSS	37	N.C.
2	DW	14	N.C.	26	VBIAS	38	N.C.
3	SK	15	N.C.	27	VREF	39	AVDD36
4	CS	16	N.C.	28	MICIN	40	MSEL
5	MUTER	17	MUTEP	29	AVDD	41	VOLUP
6	PWRSEL	18	N.C.	30	LOL	42	PDSW
7	VDD	19	LEDR	31	LOBS	43	USBDP
8	DVDD33	20	TEST	32	LOR	44	USBDM
9	N.C.	21	N.C.	33	AVSS	45	N.C.
10	MODE	22	N.C.	34	AVDD	46	N.C.
11	LEDO	23	N.C.	35	DVDD	47	VOLDN
12	DVSS	24	N.C.	36	DVSS	48	N.C.

### 4.2 Pin-out Diagram

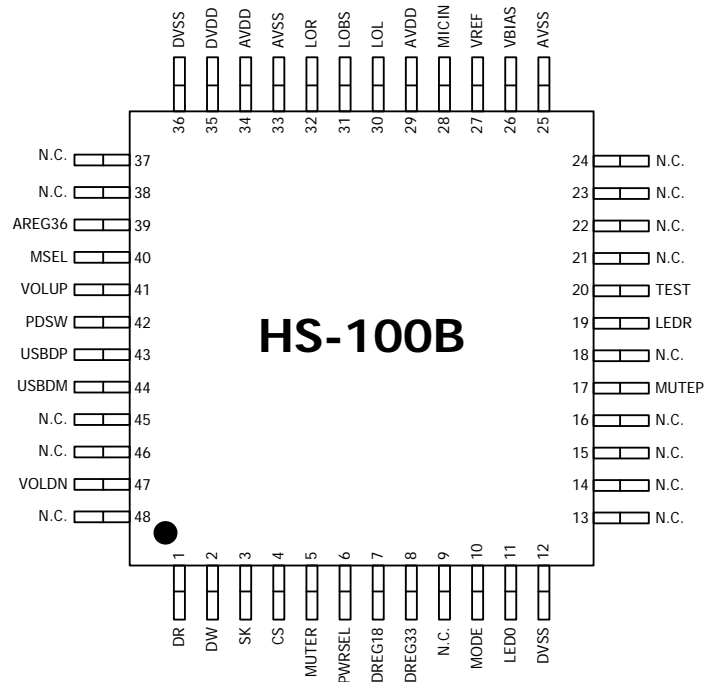

### 4.3 Pin-out Diagram

Pin #	Symbol	Type	Description
1	DR	DIO, 8mA, PD, 5VT	USB Controller Data Read From EEPROM Interface. EEPROM Data Output.
2	DW	DO, 4mA, SR	USB Controller Data Writes to EEPROM Interface. EEPROM Data Input.
3	SK	DO, 4mA, SR	EEPROM Interface Clock (100KHz)
4	CS	DO, 4mA, SR	EEPROM Interface Chip Select
5	MUTER	DI, ST, PU	Mute Recording (Edge Trigger with de-Bouncing)
6	PWRSEL	DI, ST	H: Pull Up to 3.3V; L: Pull Down to Ground Speaker Mode H : Self-Power with 100mA ; L : Bus Power with 500mA Headset Mode H : Bus Power with 100mA ; L : Bus Power with 500mA
7	DREG18	P	1.8V Regulator Output for Digital Circuit
8	DREG33	P	3.3V Regulator Output for Digital Circuit (driving current 40mA)
10	MODE	DI, ST	H: Pull Up to 3.3V; L: Pull Down to Ground L : Headset Mode: Playback & Recording H : Speaker Mode: Playback Only
11	LEDO	DO, SR, 4mA	LED for Operation; Output H for Power On; Toggling for Data Transmit
12	DVSS	P	Digital Ground
17	MUTEP	DI, ST, PU	Mute Playback (Edge Trigger with de-Bouncing)
19	LEDR	DO, SR, 4mA	LED for Mute Recording Indicator; Output H when Recording is Muted
20	TEST	DI, ST, PD	Test Mode Select Pin; Pull Low for Normal Operation
25	AVSS	P	Analog Ground
26	VBIAS	AO	Microphone Bias Voltage Supply (3V)
27	VREF	AO	Connecting to External Decoupling Capacitor for Embedded Band gap Circuit; 1.75V Output
28	MICIN	AI	Microphone Input, input impedance is 10k Ohm
29	AVDD	P	5V Analog Power for Analog Regulator Circuit
30	LOL	AO	Line Out Left Channel (Headphone Out Left)
31	LOBS	AO	DC 1.75V Output for Line Out Bias (Headphone Out Bias) as a cap-less ground
32	LOR	AO	Line Out Right Channel (Headphone Out Right)
33	AVSS	P	Analog Ground
34	AVDD	P	5V Analog Power for Analog Regulator Circuit
35	DVDD	P	5V Digital Power for Digital Regulator Circuit
36	DVSS	P	Digital Ground
39	AREG36	P	3.6V Regulator Output for Analog Circuit

40	MSEL	DI, ST	Mixer Enable/Disable pin H: Pull Up to 3.3V, L: Pull Down to Ground L: Without Mixer H: With Mixer (With Default Mute) USB Descriptors are changed accordingly
41	VOLUP	DI, ST, PU	Volume Up (Edge Trigger with de-Bouncing)
42	PDSW	DO, 4mA, OD	Power Down Switch Control (for PMOS Polarity) 0: Normal Mode, 1: Power Down Mode
43	USBDP	AIO	USB Data D+
44	USBDM	AIO	USB Data D-
47	VOLDN	DI, ST, PU	Volume Down (Edge Trigger with de-Bouncing)
13-15, 18, 21-24,3 7, 38, 45, 46,	NC	--	No functions

Note: DI - Digital Input Pin, DO - Digital Output Pin, DIO - Digital bi-Directional Pin, AI/AO/AIO - Analog Pin, SR Slew Rate Control, ST - Schmitt Trigger, PD/PU - Pull Down or Pull Up, 5VT - 5-Volt Tolerant (3.3V Pin), OD - Open Drain

## 5 USB Topology

The HS-100B supports headset and speaker topology that can be selected by MODE pin. The topology setting as following: MODE=0, Headset Topology

MODE=1, Speaker Topology

### 5.1 Headset Topology

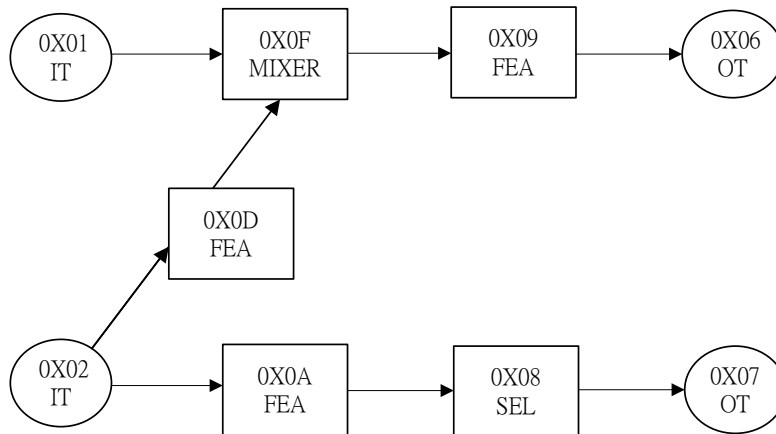

#### 5.1.1 Device Descriptor

Offset	Field	Size	Value (Hex)	Description
0	bLength	1	12	Total 18 Bytes
1	bDescriptorType	1	01	Device descriptor
2	bcdUSB	2	0110	USB 1.1 compliant
4	bDeviceClass	1	00	Device class specified by interface
5	bDeviceSubClass	1	00	Device subclass specified by interface
6	bDeviceProtocol	1	00	Device protocol specified by interface
7	bMaxPacketSize0	1	8	Endpoint zero Size = 8 bytes
8	idVendor	2	0d8c	Vendor ID
10	idProduct	2	0014	Product ID
12	bcdDevice	2	0100	Device compliant to the Audio Device Class specification version 1.00
14	iManufacturer	1	01	Index of string descriptor that characterizes manufacturer
15	iProduct	1	02	Index of string descriptor that characterizes product
16	iSerialNumber	1	00	Index of string descriptor that characterizes the device's serial number
17	bNumConfigurations	1	01	Configurations number = 1

#### 5.1.2 Configuration Descriptor

Offset	Field	Size	Value (Hex)	Description
0	bLength	1	09	Total 9 Bytes
1	bDescriptorType	1	02	Configuration Descriptor
2	wTotalLength	2	XXXX	Total length of data returned for this configuration: Programmable by MSEL and MODE pin
4	bNumInterfaces	1	04	Number of interfaces supported by this configuration: 0: control interface 1: ISO-OUT interface 2: ISO-IN interface 3: INT-IN(HID) interface
5	bConfigurationValue	1	01	Configuration value



6	iConfiguration	1	00	Index of string descriptor that characterizes this configuration
7	bmAttributes	1	80	Bus Power and support Remote Wakeup
8	bMaxPower	2	32	Maximum power consumption of the USB Device: 100mA

## 5.2 Speaker Topology



### 5.2.1 Device Descriptor

Offset	Field	Size	Value (Hex)	Description
0	bLength	1	12	Descriptor length
1	bDescriptorType	1	01	Device descriptor
2	bcdUSB	2	0110	USB 1.1 compliant
4	bDeviceClass	1	00	Device class specified by interface
5	bDeviceSubClass	1	00	Device subclass specified by interface
6	bDeviceProtocol	1	00	Device protocol specified by interface
7	bMaxPacketSize0	1	08	Endpoint zero packet size
8	idVendor	2	0d8c	Vendor ID
10	idProduct	2	0014	Product ID
12	bcdDevice	2	0100	Device release number
14	iManufacturer	1	01	Index of string descriptor that characterizes the manufacturer
15	iProduct	1	02	Index of string descriptor that characterizes the product
16	iSerialNumber	1	00	Index of string descriptor that characterizes the serial number
17	bNumConfigurations	1	01	Number of configuration

### 5.2.2 Configuration Descriptor

Offset	Field	Size	Value (Hex)	Description
0	bLength	1	09	Descriptor length
1	bDescriptorType	1	02	Configuration descriptor
2	wTotalLength	2	XXXX	Total length of data returned for this configuration: Programmable by MSEL and MODE pin
4	bNumInterfaces	1	03	Number of interfaces supported by this Configuration: 00: Control 01: ISO-Out 02: INT-IN (HID)
5	bConfigurationValue	1	01	Configuration value
6	iConfiguration	1	00	Index of string descriptor that characterizes this configuration
7	bmAttributes	1	80	Attributes (PWRSEL=0:Bus Powered, 1:SELF Powered)
8	bMaxPower	1	32	Maximum power consumption from bus = 100mA

## 6 Function Description

### 6.1 Content Format for EEPROM(93C46)

The HS-100B integrates USB transceiver, internal oscillator and regulator so that only several passive components are necessary for the USB interface connection. Default USB descriptors are embedded in the HS-100B; therefore there is no additional design effort needed for a generic USB operation. For customized product, customer can attach a SPI interface 93C46 EEPROM to override the embedded VID, PID, initial/max/min volume settings and provide addition serial number for each set. The HS-100B automatically detects 93C46 existence and performs the overwrite function during power up.

#### 6.1.1 Addressing

Each addresses has 2-byte data, prefix `0x` means hex number; given below with their respective descriptions:

Addr (Hex)	Description	
0x00	bit[15:4] Magic Word 0x670X where X = bit 4, 3, 2, 1 bit[3] The value within address 0x2A,0x2B,0x32 is valid 1: valid(default) 0: invalid bit[2] Reserved, should be 1 bit[1] Serial number enable control 1: enable, 0: disable(default) bit[0] Reserved, should be 1	
0x01	VID 2-byte	
0x02	PID 2-byte	
0x03	Serial number 1 <sup>st</sup> byte (bit15-bit8, first character)	Serial number length (bit7-bit0)
0x04 ~ 0x09	Serial number 12-byte	
0x0A	Product string 1 <sup>st</sup> byte (bit15-bit8, first character)	Product string length (bit7-bit0) [0x3E->30,0x40->31Char]
0x0B ~ 0x19	Product string 30-byte (default: USB Audio Device)	
0x1A	Manufacturer string 1 <sup>st</sup> byte (bit15-bit8, first character)	Manufacturer string length (bit7-bit0) [0x3E->30,0x40->31Char]
0x1B ~ 0x29	Manufacturer string 30-byte (default: C-Media Electronics Inc.)	
0x2A	bit[15:9] DAC initial volume (7-bit, default=-10dB) bit[8:3] ADC initial volume (6-bit, default=8dB) bit[2] DAC EEPROM MAX/MIN volume valid bit[1] ADC EEPROM MAX/MIN volume valid bit[0] AA EEPROM MAX/MIN volume valid	
0x2B	bit[15:11] AA initial volume (5-bit, default=-7dB) bit[10] Reserved, should be 0 bit[9] boost mode 0: 22dB 1:12dB(default) bit[8] Reserved, should be 0 bit[7] Total Power Control 1:enable, 0:disable(default) bit[6] Reserved, should be 0 bit[5] MIC High Pass Filter 1:enable(default), 0:disable bit[4] MIC PLL Adjust 1:enable, 0:disable(default) bit[3] MIC BOOST 1:enable (default), 0:disable bit[2] DAC Output Terminal property set to SPK or HP	

	1: Headset, 0: Speaker(default) bit[1] HID, 1: enable (default), 0: disable bit[0] Remote wakeup, 1:enable, 0:disable(default)
0x2C	bit[15:0] DAC Minimum Volume (0xD300, DAC-Min.=-37dB, default=-37dB)
0x2D	bit[15:0] DAC Maximum Volume (0x0000, DAC-Max.=0dB, default=0dB)
0x2E	bit[15:0] ADC Minimum Volume(0xEA00, ADC-Min.=-22dB, default=-12dB)
0x2F	bit[15:0] ADC Maximum Volume(0x1700, ADC-Max.=+23dB, default=+23dB)
0x30	bit[15:0] AA Minimum Volume (0xE900, AA-Min.=-23dB, default=-23dB)
0x31	bit[15:0] AA Maximum Volume (0x0800,AA-Max.+8dB, default=+8dB)
0x32	EE_OPTION2 Register bit[3] Reserved, should be 0 bit[2] Reserved, should be 0 bit[1] Reserved, should be 1 bit[0] Reserved, should be 0
~ END	

### 6.1.2 EEPROM SPI Interface Timing Information

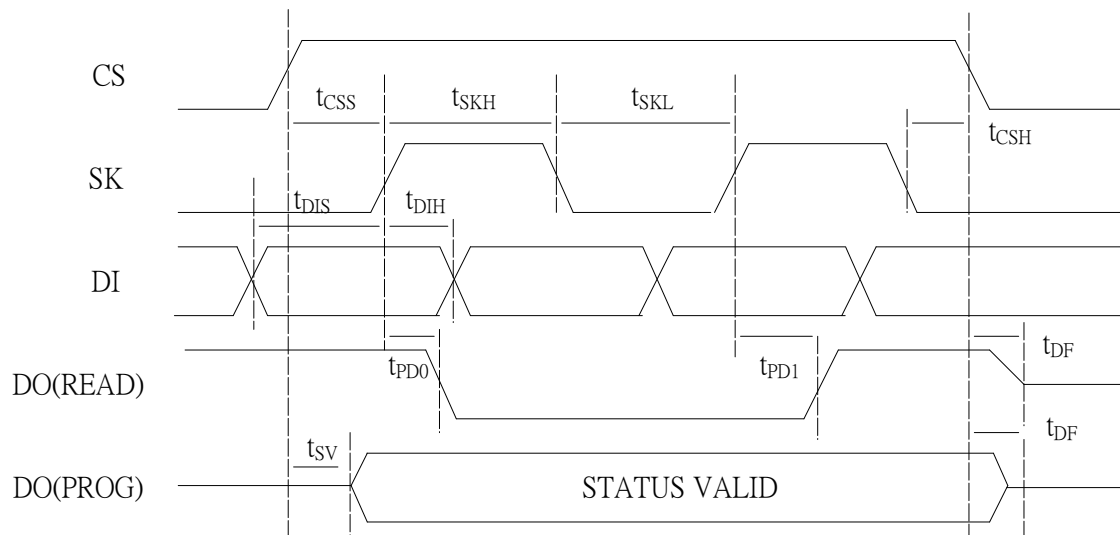

Symbol	Parameter	Test Condition*	Min	Typ	Max	Units
$f_{SK}$	SK Clock Frequency	2.7V<=Vcc<=5.5V	0		1	MHz
$t_{SKH}$	SK High Time	2.7V<=Vcc<=5.5V	250			ns
$t_{SKL}$	SK Low Time	2.7V<=Vcc<=5.5V	250			ns
$t_{CS}$	Minimum CS Low Time	2.7V<=Vcc<=5.5V	250			ns
$t_{CSS}$	CS Setup Time	2.7V<=Vcc<=5.5V	50			ns
$t_{DIS}$	DI Setup Time	2.7V<=Vcc<=5.5V	100			ns
$t_{CSH}$	CS Hold Time	2.7V<=Vcc<=5.5V	0			ns

$t_{DIH}$	DI Hold Time	$2.7V \leq V_{CC} \leq 5.5V$	100			ns
$t_{PD1}$	Output Delay to "1"	$2.7V \leq V_{CC} \leq 5.5V$			250	ns
$t_{PD0}$	Output Delay to "0"	$2.7V \leq V_{CC} \leq 5.5V$			250	ns
$t_{SV}$	CS to Status Valid	$2.7V \leq V_{CC} \leq 5.5V$			250	ns
$t_{DF}$	CS to DO in High Impedance	$2.7V \leq V_{CC} \leq 5.5V$			100	ns
$t_{WP}$	Write Cycle Time	$4.5V \leq V_{CC} \leq 5.5V$	0.1	3	10	ms

\* based on ATMEL 93C46 EEPROM data

## 6.2 Jumper Pins and Mode Setting

Several jumper pins can set the configuration of the HS-100B. These jumper pin settings affect both USB descriptors and USB audio topology. If MODE pin is switched up to 3.3V (speaker mode), a playback only function is activated and there is no recording function declared to the host. At this setting, MSEL pin is ignored and only one input terminal, one output terminal and one feature unit is initialized in USB audio topology.

If MODE pin is switched down (headset mode), a full duplex playback and recording function is reported to the host. MSEL pin setting activates one mixer unit and one feature unit. The following USB audio topology is an example of headset mode. PWRSEL pin affects the power configuration of the HS-100B, together with MODE pin totally 4 combinations are programmable.

Combinations		MODE	
		3.3V	GND
PWRSEL	3.3V	Speaker Mode: Playback Only (Self Power with 100mA)	Headset Mode: Playback + Recording (Bus Power with 100mA)
	GND	Speaker Mode: Playback Only (Bus Power with 500mA)	Headset Mode: Playback + Recording (Bus Power with 500mA)

## 6.3 HID Feature and Descriptions

USB protocols can be used to configure devices at startup or when they are plugged in during run time. These devices are divided into various device classes. Each device class defines the common behavior and protocols for devices that serve similar functions. The HID (Human Interface Device) class is one of the device classes. The HID class consists primarily of devices that are used by humans to control the operation of computer systems. HID feature is provided by the HS-100B to enable user settings to volume up, volume down, and playback mute button pin is reported to the host to synchronize host side settings. In addition, all the HS-100B internal registers can be accessed through HID function call.

### 6.3.1 HID Interface Descriptor

Offset	Field	Size	Value (Hex)	Description
0	bLength	1	09	Size of this descriptor: 9 byte
1	bDescriptorType	1	04	Interface descriptor type
2	bInterfaceNumber	1	03	Number of Interface: 3
3	bAlternateSetting	1	00	Alternate 0
4	bNumEndpoints	1	01	Number of endpoints used by this Interface: 1
5	bInterfaceClass	1	03	HID Interface Class
6	bInterfaceSubClass	1	00	No Subclass
7	bInterfaceProtocol	1	00	Must be set to 0
8	iInterface	1	00	Index of a string descriptor that characterizes this interface

### 6.3.2 HID Descriptor

Offset	Field	Size	Value (Hex)	Description
0	bLength	1	09	Total 9 Bytes
1	bDescriptorType	1	21	HID Descriptor Type
2	bcdHID	2	0100	HID class version 1.00
4	bCountryCode	1	00	
5	bNumDescriptors	1	01	
6	bDescriptorType	1	22	Report Descriptor
7	wDescriptorLength	2	003C	Numeric expression that is the total size of the optional descriptor: 60 Bytes

### 6.3.3 Interrupt in Endpoint Descriptor

Offset	Field	Size	Value (Hex)	Description
0	bLength	1	07	Total 7 Bytes
1	bDescriptorType	1	05	Endpoint Descriptor Type
2	bEndpointAddress	1	87	In Endpoint Endpoint number = 3
3	bmAttributes	1	03	Interrupt endpoint type
4	wMaxPacketSize	2	0004	Maximum packet size: 4 bytes
6	bInterval	1	2	Two(2) ms

## 7 Electrical Characteristics

### 7.1 Absolute Maximum Rating

Symbol	Parameter	Value	Unit
Dvmin	Min Digital Supply Voltage	- 0.3	V
Dvmax	Max Digital Supply Voltage	+ 6	V
Avmin	Min Analog Supply Voltage	- 0.3	V
Avmax	Max Analog Supply Voltage	+ 6	V
Dvinout	Voltage on any Digital Input or Output Pin	-0.3 to +5.5	V
Avinout	Voltage on any Analog Input or Output Pin	-0.3 to +3.96	V
TBstgB	Storage Temperature Range	-40 to +125	POPC
ESD (HBM)	ESD Human Body Mode	+4000	V
ESD (MM)	ESD Machine Mode	+200	V
Latch Up	JEDEC Standard No.78, Mar 1997	200	mA

### 7.2 Operation Conditions

Operation conditions				
	Min	Typ	Max	Unit
Analog Supply Voltage	4.5	5.0	5.5	V
Digital Supply Voltage	4.5	5.0	5.5	V
Total Power Consumption	-	37.25		mA
Suspend Mode Power Consumption	-	1.58		mA
Operating ambient temperature	-15	-	70	PoPC

### 7.3 Electrical Parameters

	Min	Typ	Max	Unit
<b>DAC (10K Ohm Loading)</b>				
Resolution	-	16	-	bits
THD + N (-3dBr)@1KHz	-	-72	-	dB
SNR	-	93	-	dB
Silent SNR	-	98	-	dB
Dynamic range	-	92	-	dB
Frequency response 48KHz	20	-	20K	hz
Frequency Response 44.1KHz	20	-	20K	hz
Output Voltage (rms)	-	0.995	-	vrms
<b>DAC (32 Ohm Loading)</b>				
Resolution	-	16	-	bits
THD + N (-3dBr)@1KHz	-	-70	-	dB
SNR	-	93	-	dB
Silent SNR	-	98	-	dB
Dynamic Range	-	92	-	dB
Frequency Response 48KHz	20	-	20K	hz
Frequency Response 44.1KHz	20	-	20K	hz
Output Voltage (rms)	-	0.442	-	vrms
<b>ADC</b>				
Resolution	-	16	-	bit
THD + N (-3dBr)@1KHz	-	-84	-	dB
SNR	-	90	-	dB
Dynamic Range	-	88.5	-	dB
Frequency Response 48KHz	100	-	20K	hz
Frequency Response 44.1KHz	100	-	20K	hz
Input Range	0	-	2.88	vpp
<b>Amplification</b>				
Volume Control Initial Value		-10		dB
Volume Control Level	-37	-	0	dB
Volume Control Step	-	38	-	steps
<b>Microphone Input</b>				
Boost Gain	-	12/22 (EEPROM)	-	dB
Gain Adjustment Initial Value		8		
Gain Adjustment Range	-12	-	23	dB
Gain Adjustment Steps	-	36	-	steps
Mixer Gain Initial Value		-7		
Mixer Gain Adjustment	-23.0	-	8.0	dB
Mixer Gain Adjustment Steps	-	32	-	steps



## 8 Package Dimensions

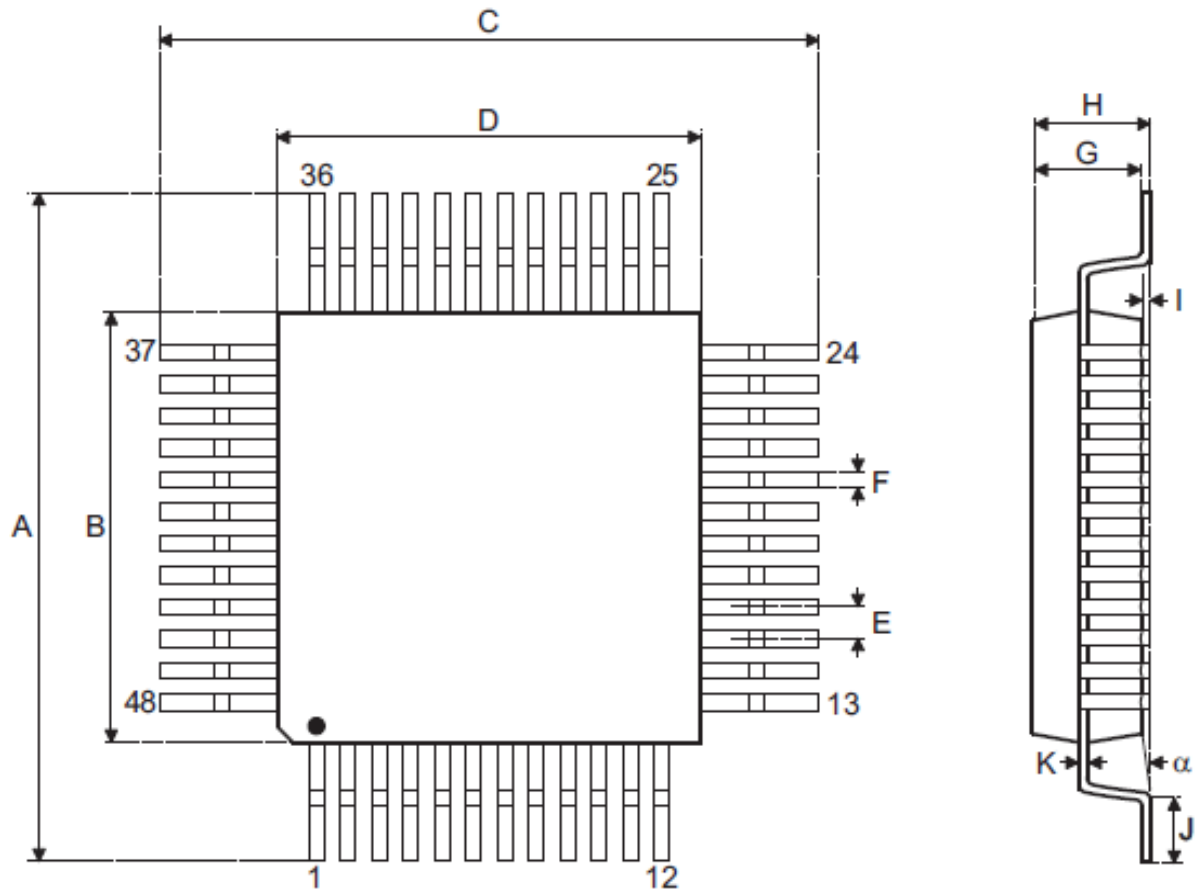

Symbol	Dimensions in mm		
	Minimum	Normal	Maximum
A	8.90	—	9.10
B	6.90	—	7.10
C	8.90	—	9.10
D	6.90	—	7.10
E	—	0.50	—
F	—	0.20	—
G	1.35	—	1.45
H	—	—	1.60
I	—	0.10	—
J	0.45	—	0.75
K	0.10	—	0.20
$\alpha$	0°	—	7°

---

## Reference

- Universal Serial Bus Specification, Version 2.0
- Universal Serial Bus Device Class Definition for Audio Devices, Version 1.0.
- Universal Serial Bus Device Class Definition for Human Interface Devices, Version 1.11

— End of Datasheet —

C-MEDIA ELECTRONICS INC.  
6F., 100, Sec. 4, Civil Boulevard, Taipei, Taiwan 106 R.O.C.  
TEL : +886-2-8773-1100  
FAX : +886-2-8773-2211  
E-MAIL : sales@cmedia.com.tw

### Disclaimer:

Information provided by C-Media Electronics Inc. is sworn to be accurate and reliable. However, no responsibility is assumed by C-Media Electronics Inc. for its use, nor for any infringements of patents or other rights of third parties that may result from its use. Specifications can be subjected to change without notice. No license is granted by implication or otherwise under any patent or patent rights of C-Media. Trademarks registered or not are the property of their respective owners.

## X-ON Electronics

Largest Supplier of Electrical and Electronic Components

*Click to view similar products for [Audio DSPs](#) category:*

*Click to view products by [Cmedia](#) manufacturer:*

Other Similar products are found below :

[E-TDA7377A](#) [TDA7716N](#) [BR281W31A101V1G](#) [LC823425-12G1-LR-H](#) [TDA7419N](#) [R3910-CFAB-E1B](#) [HMC474MP86ETR](#)  
[AMIS30660CANH6G](#) [B300W35A102XYG](#) [MAX9892ERT+T](#) [MAX9892ELTT](#) [SB3229-E1](#) [NJW1157BFC2](#) [ZL38060LDG1](#) [SB3231-E1](#)  
[HMC1022-SX](#) [SA3229-E1-T](#) [LC75056PE-H](#) [TDA7729](#) [NJW1195AV](#) [WM5102ECS/R](#) [CI1103](#) [WM5102ECS/R](#) [100-CG1820](#) [CS48L10-](#)  
[CNZ](#) [CS48L10-CNZR](#) [CS47024C-CQZ](#) [CS48L10-CWZR](#) [CS48L11-CNZ](#) [HMC618LP3ETR](#) [HMC604LP3ETR](#) [HMC5622LS7TR](#)  
[HMC288MS8ETR](#) [HMC240A](#) [STA323W13TR](#) [BU9408KS2](#) [DSPB56725AF](#) [TAS3204PAGR](#) [ADAU1467WBCPZ300](#)  
[ADAU1463WBCPZ300](#) [BD37514FS-E2](#) [ADAU1463WBCPZ150](#) [ADAU1466WBCPZ300](#) [NJM2294V-TE1](#) [LC823450TA-2H](#) [NJM2537V-](#)  
[TE1](#) [TWL1103TPBSQ1](#) [LC823450XDTBG](#) [HMC-AUH312-SX](#) [ADAV4622BSTZ](#)